

Drive solutions for belt conveyors in the bulk materials industry

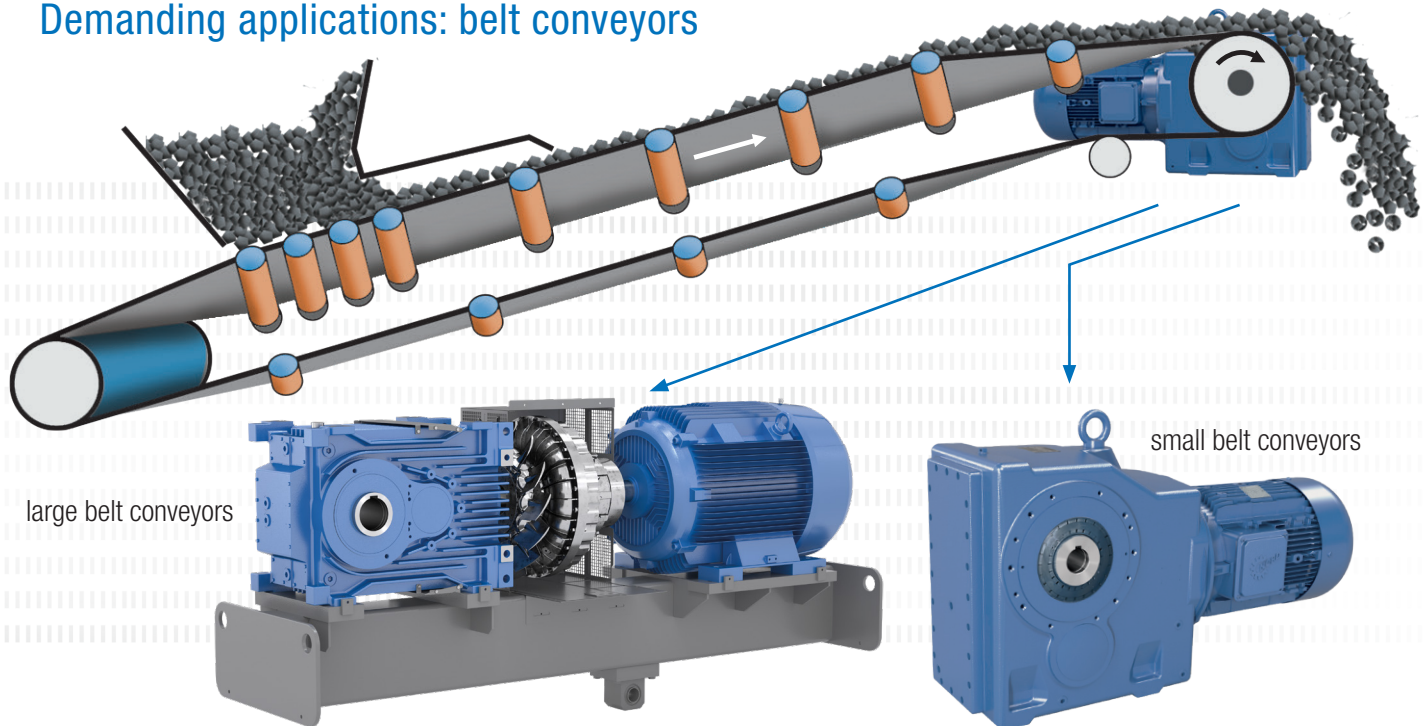

Reliable under extreme conditions:
NORD DRIVESYSTEMS supplies suitable and robust
drives for large and small belt conveyor systems.

Demanding applications: belt conveyors



Belt conveyors are used for the transportation of bulk materials in continuous operation. They consist of an endless conveyor belt which runs on support rollers. The belt is used both as the means of transport and the provider of movement. They enable economical transportation of large quantities over long distances. Conveyor lengths range from a few metres to several kilometres.

The belts can run horizontally, or rise or fall. Combinations are also possible. The entire drive system is designed on the basis of the quantity and properties of the material to be transported and the ambient and operating conditions. This ensures that the drive system is optimally matched to the application. For example it is necessary to reduce the strain on the belt during starting.

Drive solutions for belt conveyors in the bulk materials industry

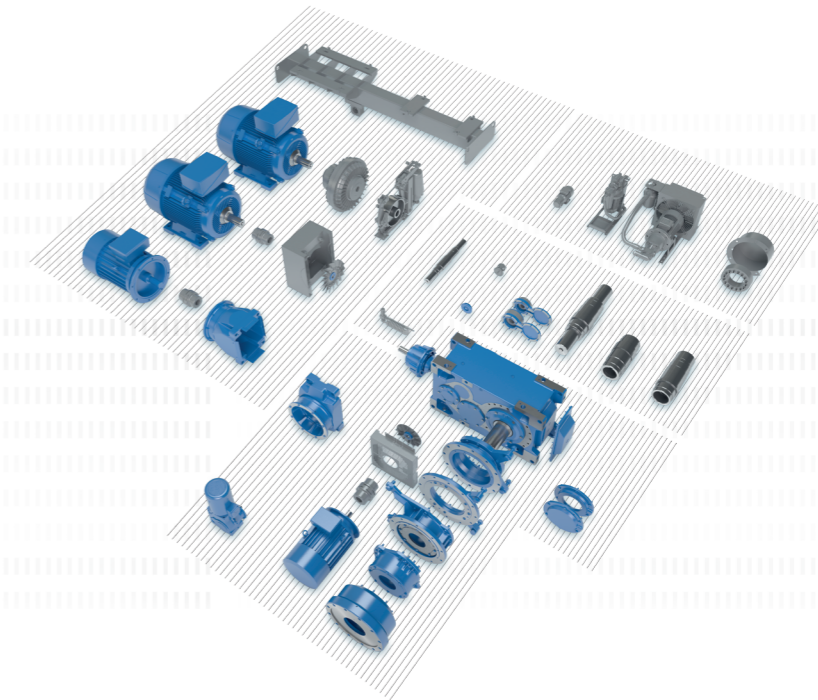

Drive solutions for large belt conveyors

MAXXDRIVE® industrial gear units (Catalogue G1050)

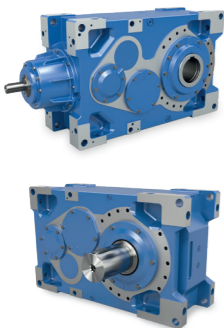

- ✓ Universal gear units
- ✓ Helical gear units 2- and 3-stage
Helical bevel gear units 3- and 4-stage
- ✓ Multiple mounting and cooling options
- ✓ Modified bearing options for high radial and axial load capacity
- ✓ Compact design
- ✓ All installation positions

Sizes: 11
Power: 1.5 – 4,000 kW
Torque: 15,000 – 282,000 Nm
Speed ratio: 5.54 – 30,000:1

MAXXDRIVE® XT industrial gear units (Catalogue G1050)

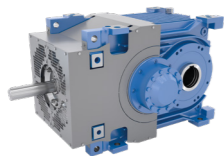

- ✓ Optimised housing and surface design for maximum power at high temperatures
- ✓ No separating joints in the housing, therefore no sealing-surfaces subject to torque
- ✓ All bearings and sealing-surfaces are machined in a single process (quieter running and longer service life)
- ✓ High-precision axis alignment for quiet running
- ✓ Long life, low maintenance
- ✓ Angled gear units

Size: 7
Power: 50 – 1,500 kW
Torque: 15,000 – 75,000 Nm
Ratio: 6,14 – 22,91:1

- ▶ MAXXDRIVE® industrial gear units (hollow or solid shaft)
- ▶ Foot mounted motor (IEC B3)
- ▶ Hydraulic coupling
- ▶ Back stop
- ▶ Brake
- ▶ All components are mounted on a motor rocker or frame
- ▶ High efficiency IE3 motor
- ▶ ATEX motors for conveyor belts in explosion hazard areas

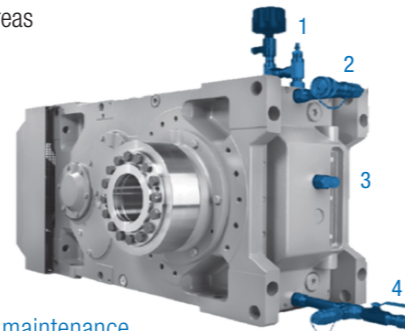

The NORD maintenance package is a combination of protective measures which ensures that your investment will continue to function for a long time to come.

- 1 Drying agent filter
- 2 Quick fit filter trolley connection
- 3 Oil inspection glass
- 4 Quick fit filter trolley connection and oil drain cock

Recommended options for large belt conveyors

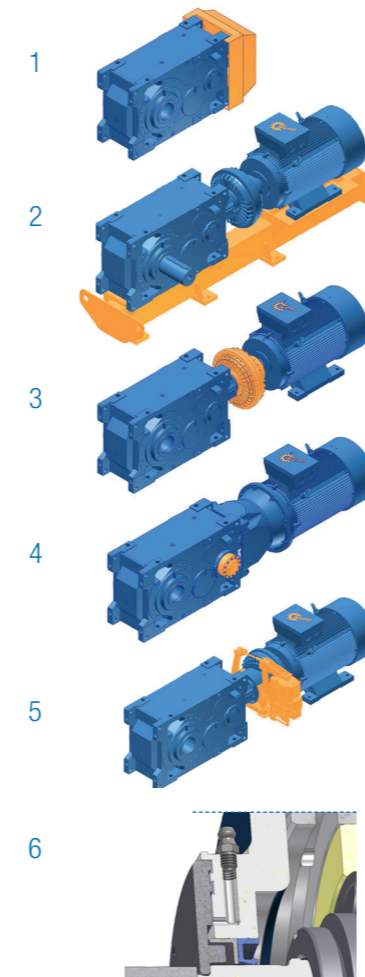

MAXXDRIVE® industrial gear units are based on the modular system from NORD DRIVESYSTEMS and provide many individual options such as:

- 1 Axial fans**
The high performance axial fan is mounted directly on the drive shaft and provides a high cooling power and a thermal reserve.
- 2 Base frame / motor rocker**
All mechanical and electrical components are mounted on a motor rocker or a motor frame, which simplifies the installation of the drive train.
- 3 Fluid coupling**
The fluid coupling enables the conveyor belt to start gently and therefore prevents excessive tensile forces on the belt and high toques in the gear unit. In addition, it reduces the starting current.
- 4 Back stop**
The back stop prevents run-back with inclined conveyor belts. All back stops are externally mounted and can be replaced without having to dismantle the gear unit. The back stops are also lubricated with the gear oil.
- 5 Auxiliary drive unit**
Auxiliary drive incl. overrunning clutch when it becomes necessary to operate the system at slow speed or "inch" the main reducer.
- 6 Taconite seal**
The Taconite seal prevents damage to the shaft sealing rings in abrasive or dusty environments. It consists of a labyrinth seal which can be re-lubricated to keep abrasive dust away from the seal.

Drive solutions for belt conveyors in the bulk materials industry



Drive trains for large belt conveyors

Hollow shaft with shrink disc and motor rocker

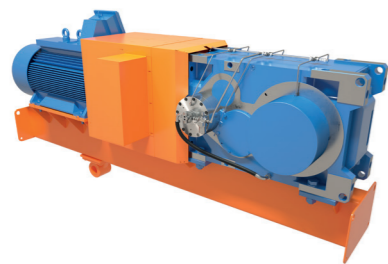

Solid shaft with flange coupling and motor rocker

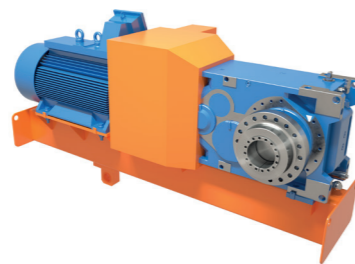

Solid shaft with output coupling and motor frame

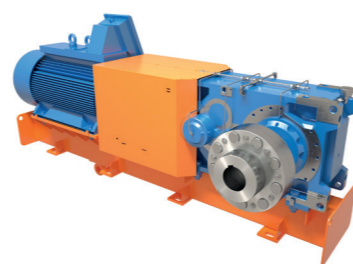

Advantages

- ▶ Simple installation of the entire drive, as no alignment of the motor rocker is required

- ▶ Simple installation of the entire drive, as no alignment of the motor rocker is required
- ▶ Simple disassembly even after long periods of operation by loosening the screw connections of the flange coupling

- ▶ Simple disassembly even after long periods of operation
- ▶ Damping of peak loads or vibrations by the elastic coupling
- ▶ No reaction forces on the output bearings and output shafts

Disadvantages

- ▶ Difficult to disassemble after long periods of use
- ▶ No damping of peak loads or vibrations

- ▶ Higher external reaction forces on output bearings and output shafts
- ▶ No damping of peak loads or vibrations

- ▶ Alignment of the frame necessary during installation

Drive solutions for the bulk materials industry

DER ANTRIEB

Reliable. Versatile. Global.

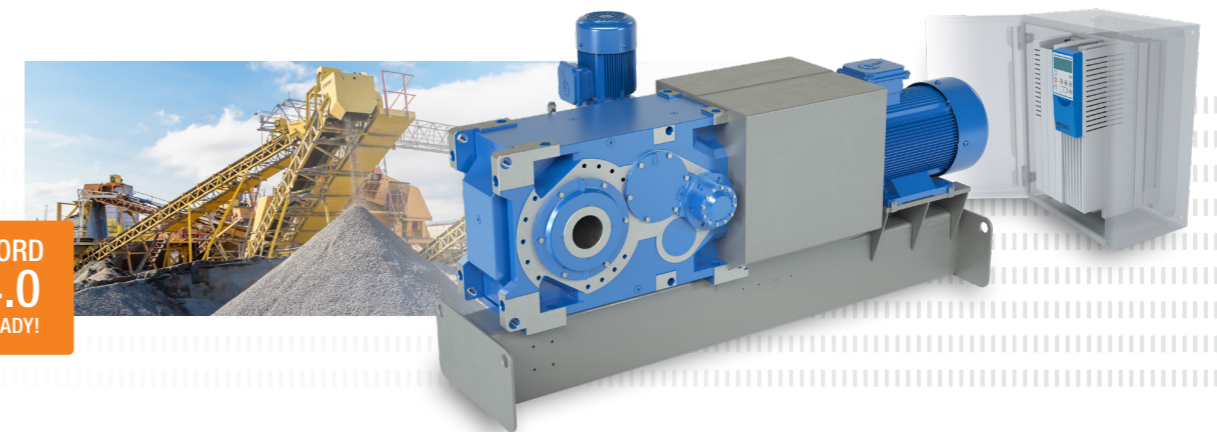

NORD 4.0 READY!

The gear units

- ▶ Strong bearings
- ▶ Quiet running

The motors

- ▶ High efficiency
- ▶ Global standards

The drive electronics

- ▶ Compact design
- ▶ Easy implementation



Versions and options for small belt conveyors

UNICASE bevel gear units (Catalogue G1000)

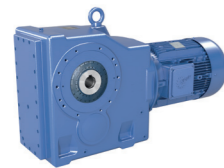

- ✓ Foot, flange or hollow shaft mounted
- ✓ Hollow or solid shaft
- ✓ Long life, low maintenance
- ✓ UNICASE housing

Sizes: 11
 Power: 0.12 – 200 kW
 Torque: 180 – 50,000 Nm
 Speed ratio: 8.04 – 13,432.68:1

UNICASE parallel shaft gear units (Catalogue G1000)



- ✓ Foot or flange-mounted
- ✓ Die-cast aluminium housing
- ✓ UNICASE housing
- ✓ Industry standard dimensions

Size: 15
 Power: 0.12 – 200 kW
 Torque: 110 – 100,000 Nm
 Ratio: 4.03:1 – 15,685.03:1

Gear unit options recommended by NORD DRIVESYSTEMS

Name	Meaning
A	Hollow shaft
AZ	Hollow shaft, B14 flange
AZD	Hollow shaft, B14 flange, with torque arm
AZK	Hollow shaft, B14 flange, with torque console
BH	Fastening element for hollow shaft with cover as a touch guard
G	Rubber buffer for torque arm (parallel shaft gear unit)
SH	Hollow shaft with shrink disc and cover as a touch guard

Motor options recommended by NORD DRIVESYSTEMS

RLS	Back stop
IP66	Protection against entry of water and dust
PTC/KTY/PT100	Temperature sensor
High efficiency motors	
ATEX	Explosion protected motors for explosion hazard areas



NORD explosion protected drive solutions

Drive systems for explosion hazardous areas zones 1, 2, 21 or 22

NORD DRIVESYSTEMS supplies customised explosion protected motors and geared motors. Systems based on top quality components are designed according to application in compliance with specific customer requests.

- ▶ Versions and equipment according to individual requirements
- ▶ Configuration processes validated according to ISO 9001
- ▶ Safe, SAP-supported modular system

Dust explosion protected motors

- ▶ According to category 2D or 3D
- ▶ For zone 21 or 22
- ▶ According to EN 60079-31
- ▶ Ignition protection Ex t (Protection by housing)

Dust explosion protected gear units

- ▶ According to category 2D or 3D
- ▶ For zone 21 or 22
- ▶ According to EN 13463
- ▶ Ignition protection c (Design protected)

Frequency inverter controlled belt conveyors

Advantages

- ▶ Easy commissioning
- ▶ Variable speed
- ▶ Adjustable torque ramp
- ▶ Safety functions
- ▶ High efficiency
- ▶ Load dependent speed control reduces wear
- ▶ Parameterisation according to process requirements

NORDAC FLEX SK 200E frequency inverter (Catalogue E3000)

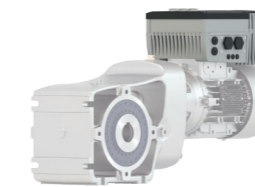

- ✓ Energy-saving function
- ✓ Integrated POSICON positioning control
- ✓ Integrated PLC

Voltage: 1~ 110 – 120 V, 1~ 200 – 240 V
 3~ 200 – 240 V, 3~ 380 – 500 V
 Power: 0.25 – 22 kW

NORDAC PRO SK 500E frequency inverter (Catalogue E3000)



- ✓ Stand-alone operation
- ✓ 4 parameter sets
- ✓ Sensorless current vector control (ISD control)
- ✓ Integrated PLC

Voltage: 1~ 110 – 120 V, 1~ 200 – 240 V
 3~ 200 – 240 V, 3~ 380 – 480 V
 Power: 0.25 – 160 kW

NORD DRIVESYSTEMS

Drive solutions for belt conveyors in the bulk materials industry

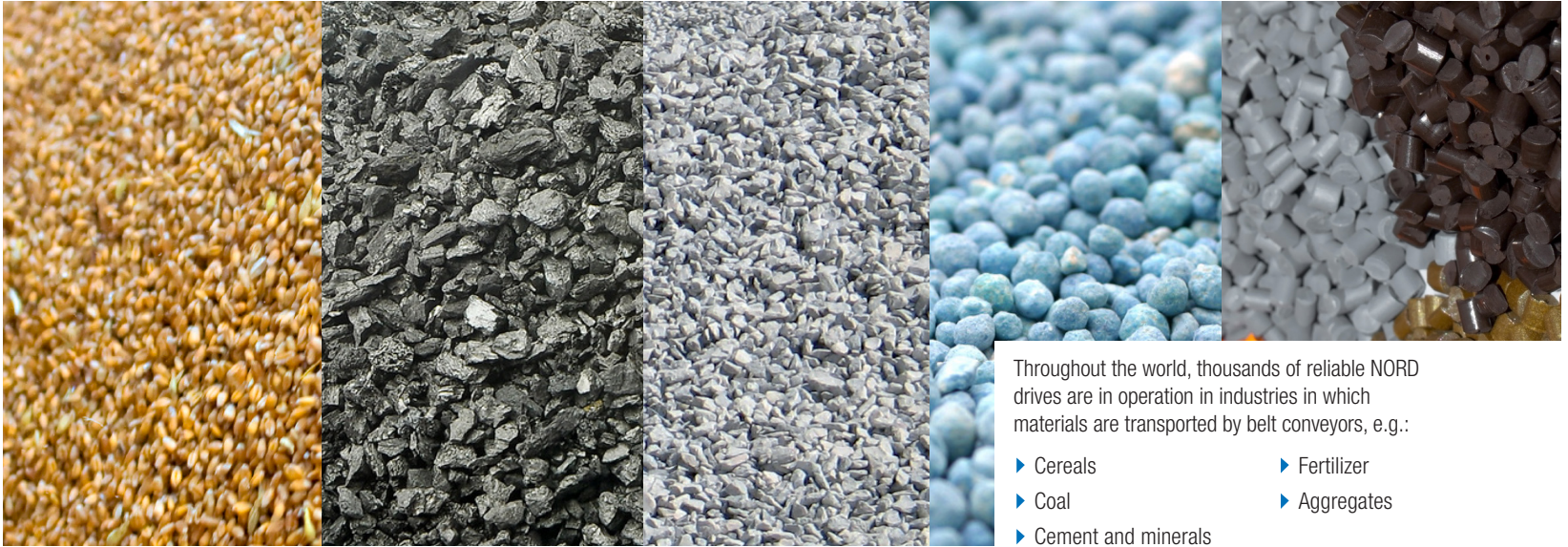

Throughout the world, thousands of reliable NORD drives are in operation in industries in which materials are transported by belt conveyors, e.g.:

- ▶ Cereals
- ▶ Coal
- ▶ Cement and minerals
- ▶ Fertilizer
- ▶ Aggregates

Complete drive solutions from a single source

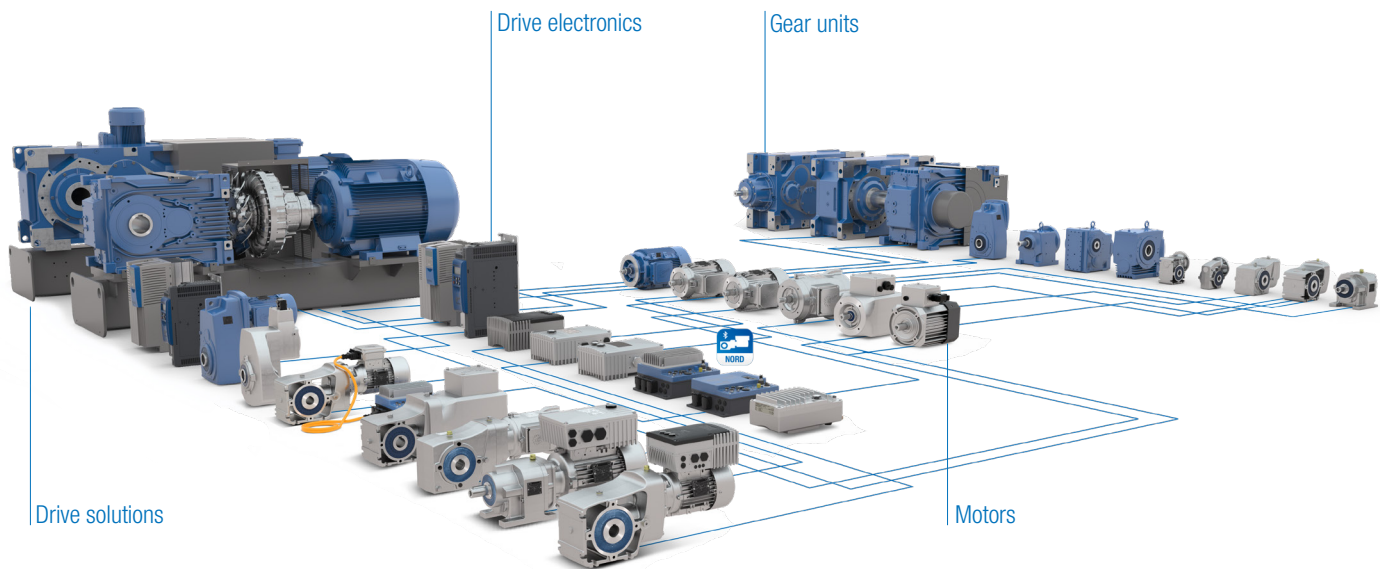

NORD DRIVESYSTEMS Group

- ▶ Family business from Bargteheide near Hamburg with more than 4,100 employees
- ▶ Drive solutions for more than 100 branches of industry
- ▶ 7 production locations worldwide
- ▶ Present in 98 countries on 5 continents
- ▶ More information: www.nord.com

Headquarters:
Getriebebau NORD GmbH & Co. KG
Getriebebau-Nord-Str. 1
22941 Bargteheide, Germany
T: +49 45 32 / 289 0
F: +49 45 32 / 289 22 53
info@nord.com

Member of the NORD DRIVESYSTEMS Group

EN – AS0304 Part No. 6045802/2821