



## Drive solutions for the grain industry

Gear units, motors, and variable frequency drives



# Complete drive solutions from a single source



## NORD Delivers

NORD offers first-class customer service and support along with full-featured drive solutions that can tackle the toughest requirements. All components are carefully selected and precisely configured to meet your exact specifications. In the rare case that standard components won't meet your needs, our in-house engineering team will work with you to design custom components or a complete customized system.

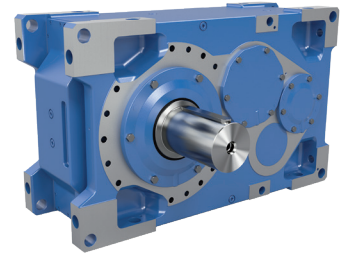

## Reduce Lead Times and Decrease Inventory

- ▶ Fastest lead times in the industry with NO expedite fees
- ▶ Over 20,000,000 standard configurations to reduce or eliminate the need for custom components
- ▶ Modular drives, motors, and electronic controls minimize inventory of replacement units and parts



## Global Product Designs, Standards, and Support

- ▶ Innovative, industry-standard products to support a wide range of applications
- ▶ Global sales and support network
- ▶ Dedicated mechanical and electrical application engineers ready to assist you
- ▶ Online resources available to you any time
- ▶ 24/7/365 emergency breakdown service

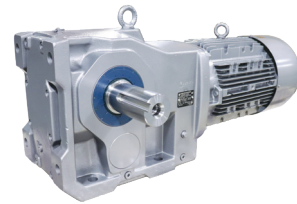

## Increase Efficiency and Reduce Operation Costs

- ▶ myNORD online tools for fast selection, configuration, ordering, and tracking of your drive units
- ▶ Drive systems that are perfectly matched to your application for optimum performance and energy efficiency
- ▶ Program personalization, such as weekly shipment schedules and custom nameplates
- ▶ Partner with a company that is easy to do business with and wants to see you succeed!





### Integrated solutions for the special requirements of the grain industry

- ▶ Simple commissioning
- ▶ Easy maintenance
- ▶ Clean, safe, and reliable operation
- ▶ Variant reduction
- ▶ Lower total cost of ownership
- ▶ Modular design
- ▶ Energy savings
- ▶ Project and product support
- ▶ Global NORD network

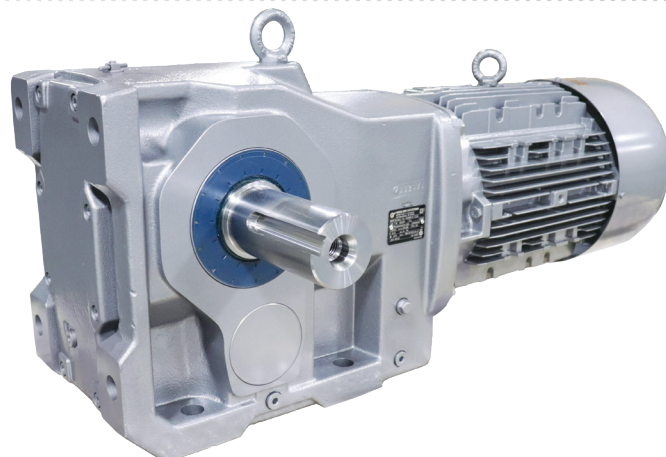

# Drive solutions for the grain industry

## 1 Drag Conveyors

NORD's flexible, modular design allows drag conveyors to adapt to nearly every plant layout to transport bulk materials effectively.

## 3 Rotary Valves / Feeders / Slide Gates

Precision options from NORD allow materials to be easily regulated, measured, and dosed by rotary valves, feeders, or slide gates, ensuring correct material flow throughout processing.

## 4 Rotary Screw Silo Reclaimers

NORD drives allow for efficient, reliable removal of material residues from silo grounds.

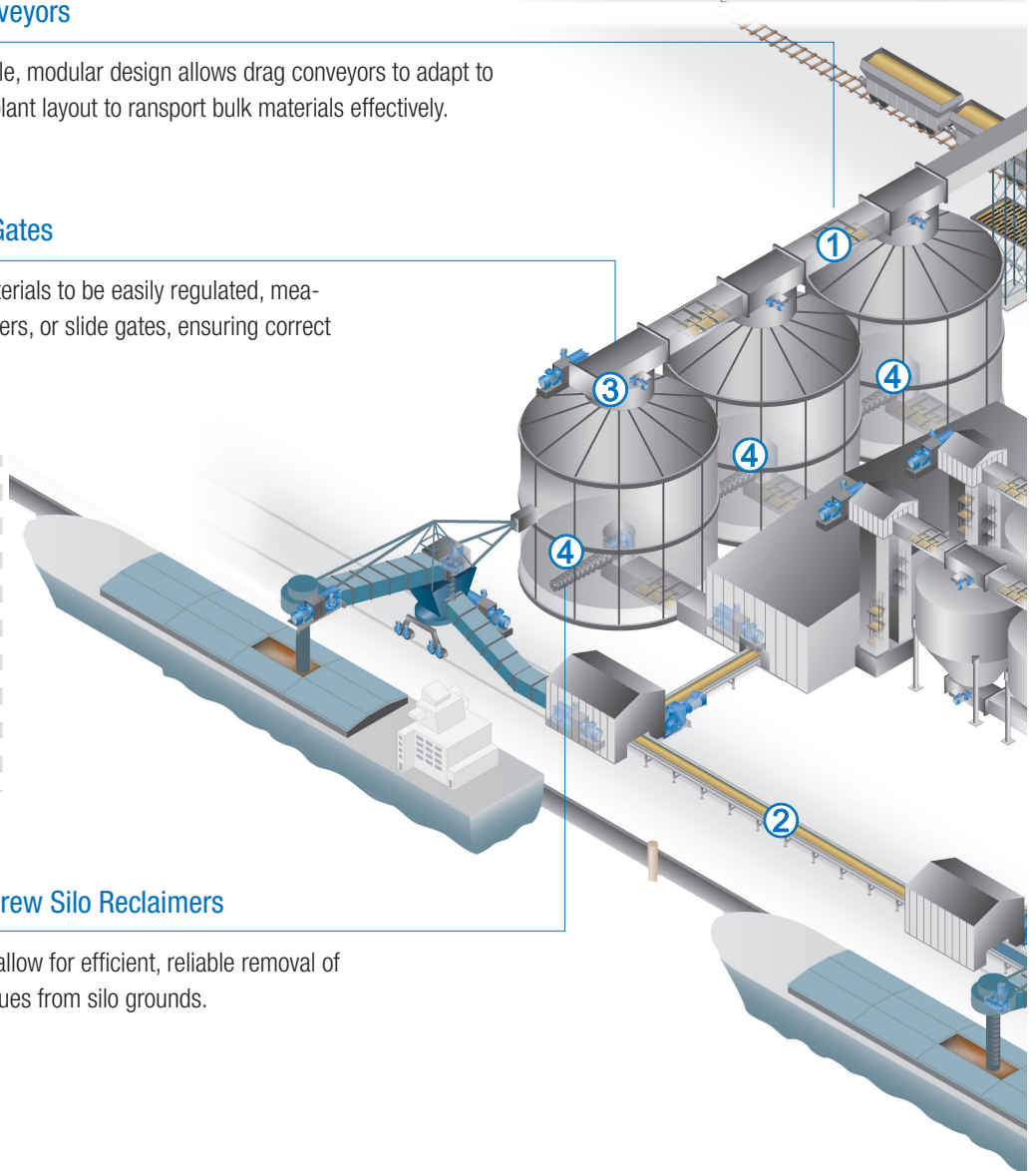
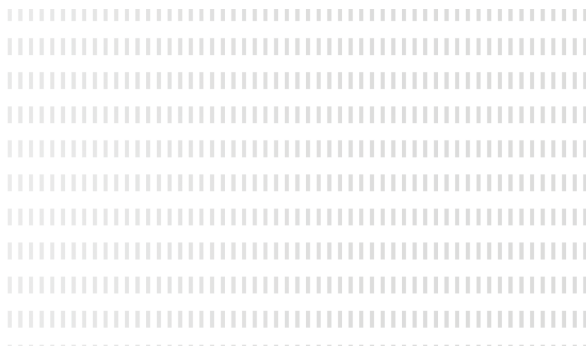

NORD DRIVESYSTEMS is a globally active provider of robust, reliable drive technology, including drives for the specialized environments of the grain industry. NORD designs customized, individual drive solutions that meet the requirements of most grain production, processing, and packaging applications.

### Terminals

- ▶ Receiving
- ▶ Storage / conveying
- ▶ Load out

### Grain silo plants

- ▶ Port facilities
- ▶ Rail
- ▶ Truck

### Processing

- ▶ Canola crushing
- ▶ Flour mills
- ▶ Feed mills
- ▶ Fertilizer storage
- ▶ Blending facilities

## 5 Screw Conveyors

NORD's screw conveyor package allows for efficient transport of material within a screw conveying system.

## 6 Bucket Elevators

Powerful, reliable vertical transport is possible with drive solutions from NORD.

## 2 Belt Conveyors

NORD high-efficiency gear units are ideal for large volume, long-distance, and single outlet conveying systems.

### NORD DRIVESYSTEMS provides:

- ▶ Strong application knowledge and technical support with the experience of thousands of installed units in the grain industry
- ▶ Complete drive solutions from a single source
- ▶ Strong worldwide presence and support
- ▶ Large product portfolio with high quality standards
- ▶ Highest reliability and robustness in certifications: ISO 9001, UL, CSA, GHOST-R, CCC, and ATEX

# Drive solutions for the grain industry

NORD DRIVESYSTEMS develops and manufactures scalable drive solutions for all areas of the grain industry.

NORD DRIVESYSTEMS developed the revolutionary UNICASE™ gear unit housings in the early 1980's. These fully enclosed housings combine all of the gear unit's components and is machined from a single piece of material.

- ▶ Housing block integrates all bearing points
- ▶ Complete machining in a single step
- ▶ High output torque
- ▶ High axial and radial load capacity
- ▶ Ultimate reliability
- ▶ Long service life
- ▶ Quiet operation



## Drag Conveyors

Flexible, fully-closed designs and the ability to handle dry, free-flowing materials make drag conveyors ideal transport systems within the grain industry. NORD's drive solutions are clean, safe, and reliable with additional environmental advantages. They also help these conveyors to cause minimal product abrasion during conveying and less horsepower required per volume of material.

- ▶ Foot, flange, or shaft mounting
- ▶ UNICASE cast iron housing
- ▶ Air breather to prevent bearing and gear damage
- ▶ 90.1 helical bevel geared motors offer infinite-life gears and high permissible radial forces
- ▶ Parallel shaft geared motor available for areas with limited space

## Belt Conveyors

NORD drive solutions power belt conveyors used for high capacity, long distance, and single-outlet conveying at low horsepower. Highly configurable options provide a multitude of solutions for these conveyor systems with added features, such as:

- ▶ Hydraulic couplings or VFD for soft start
- ▶ Backstop option to prevent material flow back
- ▶ Special sealing solutions
- ▶ Shrink disc or GRIPMAXX™ for easy installation and removal
- ▶ Torque console, and torque arms

## Rotary Valves/Feeders/Slide Gates

Exact positioning and constant, flexible speeds are critical for grain applications. Rotary valves, feeders, and slide gates can be easily regulated with NORD gear units to precisely measure and dose, ensuring correct material flow throughout the designated processes.

- ▶ Corrosion-resistant versions available
- ▶ Reverse operation option to remove material blockage (e.g. stones)
- ▶ Foot, flange, or shaft mounting
- ▶ Space-saving design
- ▶ Special sealing solutions

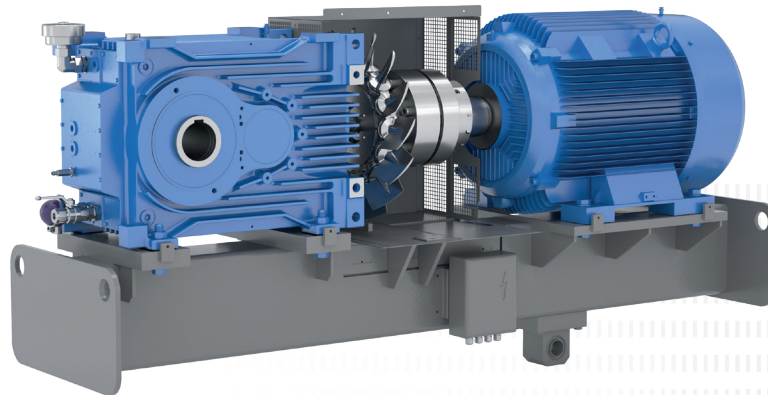

### Rotary Screw Silo Reclaimers

Intelligent torque control solutions and reverse direction modes protect silo reclaimer applications against overloads caused by bigger, harder materials during removal. NORD offers over 20,000,000 standard gear motor configurations, but can also provide custom solutions for highly specialized bulk material applications.

- ▶ UNICASE cast iron housing
- ▶ Foot, flange, or shaft mounting
- ▶ Reinforced bearing designs for high axial and radial loads
- ▶ Intelligent drive electronics and torque control

### Screw Conveyors

Screw conveyors are used often for grain and bulk material transport. NORD offers highly-precise drive solutions to accommodate horizontal, inclined, or vertical transport over a specific distance, so materials can be accurately metered.

- ▶ UNICASE cast iron housing
- ▶ Screw conveyor package or shaft mount
- ▶ Reinforced bearing designs for high axial and radial loads
- ▶ Intelligent drive electronics and torque control

### Bucket Elevators

Bucket elevators are ideal for vertical transport of bulk materials. NORD provides flexible drive solutions for these transport systems, including those with high torque and other specialized requirements.

- ▶ Backstop option to prevent material flow back
- ▶ Auxiliary drive with overrunning clutch and incremental encoder available for maintenance mode
- ▶ Special sealing solutions
- ▶ Hydraulic couplings or VFD for soft start
- ▶ Swing base
- ▶ Direct, NEMA, or IEC mounted motors

# Drive solutions for the grain industry

Safe, reliable, and efficient drive solutions from a single source



## Clean & Safe

NORD DRIVESYSTEMS efficient and reliable reducers, motors, and variable frequency drives contribute to a clean and safe design. By offering a neat and compact direct drive alternative, the application is free of straps and has no exposure of rotating components.

- ▶ Optimized drive selections – designed with safety in mind
- ▶ Reduced pinch points and external rotating components
- ▶ Bolt on carriers and housing splits are eliminated

## Reliable

Downtime is something unsustainable in the grain industry. To keep key operations safe and profitable, NORD DRIVESYSTEMS uniquely designed components work in unison and are highly reliable.

- ▶ Industry leading ratio range and mounting option flexibility
- ▶ UNICASE gear housings provide accurate positioning of bearings and shafts
- ▶ Air breather helps ensure a leak-free design
- ▶ Infinite-life, high quality gearing
- ▶ Exceptional durability, quiet operation and long service life
- ▶ Coupling, cooling and swing base options
- ▶ Predictive Maintenance features

## Efficient

NORD DRIVESYSTEMS is committed to reduce carbon emissions harmful to our environment. NORD motors offer superior insulating materials, low temperature rise and voltage spike resistance.

- ▶ Low inertia, VFD rated motors meet the latest global energy requirements
- ▶ Efficient operation and optimized motor performance
- ▶ Reduced operating temperatures
- ▶ Longer service life and lower total cost of ownership

## Grain Endurance Package

The Endurance Package from NORD DRIVESYSTEMS is a combination of several protective measures that ensure your investment will have a long operating life.

- 1 Drying agent filter
- 2 Oil sampling point
- 3 Quick fit filter trolley connection
- 4 Oil inspection glass
- 5 Quick fit filter trolley connection and oil drain cock

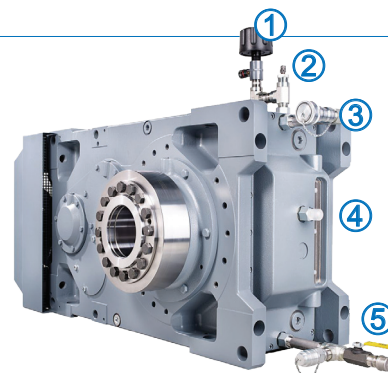



## MAXXDRIVE® Industrial gear units (Catalog: G1050)

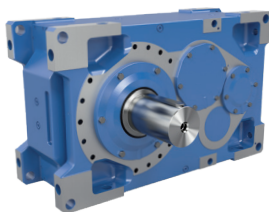

- ✓ Parallel axis and right-angled gear units
- ✓ High axial load capacity
- ✓ Long life, low-maintenance
- ✓ UNICASE housings
- ✓ Hollow or solid shaft
- ✓ Foot motor (IEC B3)
- ✓ Hydraulic clutch
- ✓ Backstop
- ✓ Brake
- ✓ All components can be mounted on a motor swing arm or a steel frame.
- ✓ High Efficiency IE3 motor
- ✓ ATEX motors for applications in explosive environments

Sizes: 11  
 Power: 2.5 – 8,075 HP  
 Torque: 132,000 – 2,495,900 lb-in  
 Ratio: 5.54:1 – 30,000:1

## MAXXDRIVE® XT Industrial gear units (Catalog: G1050)

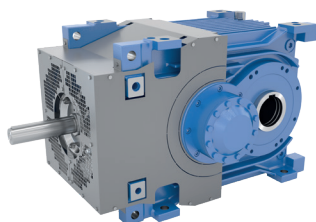

- ✓ Optimized housing and surface design for maximum power at high temperatures
- ✓ No separating joints in the housing, therefore no sealing-surfaces subject to torque
- ✓ All bearings and sealing-surfaces are machined in a single process (quieter running and longer service life)
- ✓ High-precision axis alignment for quiet running
- ✓ Long life, low maintenance
- ✓ Angled gear units

Sizes: 7  
 Power: 30 – 2,825 HP  
 Torque: 132,800 – 663,800 lb-in  
 Ratio: 6.14:1 – 22.9:1

## Screw Conveyor Package (Catalog: G1129)

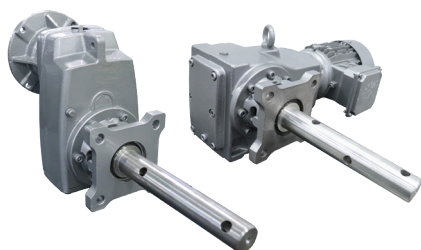

- ✓ Direct coupled input design
- ✓ Closely stepped ratios
- ✓ Standard CEMA mounting
- ✓ Compact and cost-effective

Sizes: 11  
 Performance: 0.16 – 60 HP  
 Torque: Up to 53,100 lb-in  
 Ratio: 4.32:1 – 4,246.38:1

## GRIPMAXX™ (Flyer: F5210)

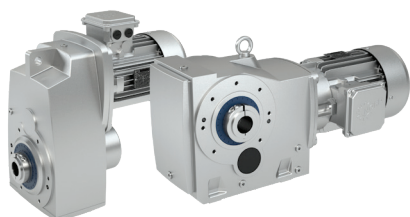

A keyless bushing system for shaft-mounting drives that can accommodate a wide range of solid shaft sizes while ensuring high-capacity, zero-backlash fit. Eliminates assembly and disassembly challenges by offering generous clearances for easy installation and removal of the gearbox.

# Gear units, motors, and variable frequency drives

## Motors

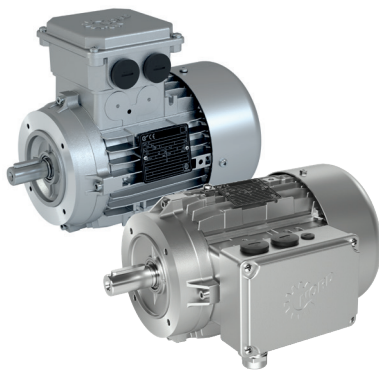

- ✓ IE3 motors from 0.16 HP / 0.12 kW (Size 63)
- ✓ IE4/IE5+ synchronous and asynchronous motors



### Explosion protected drive solutions

NORD DRIVESYSTEMS supplies customized explosion protected motors and geared motors.

- ▶ Versions and equipment according to individual requirements
- ▶ Configuration processes validated according to ISO 9001
- ▶ Safe, SAP-supported modular system

#### Dust explosion protected motors

- ▶ Category 2D or 3D, Zone 21 or 22
- ▶ According to EN 60079-31
- ▶ Ignition protection type Ex t (protected by housing)

#### Gas explosion protected gear units

- ▶ Category 2D or 3D, Zone 21 or 22
- ▶ According to EN 13463
- ▶ Ignition protection Type C (design safety)

#### Hazardous locations

- ▶ Class I, Division 2 Groups A, B, C, D
- ▶ Class II, Division 2 Groups F and G Temp Code T3B

## UNICASE helical gear units (Catalog: G1000)

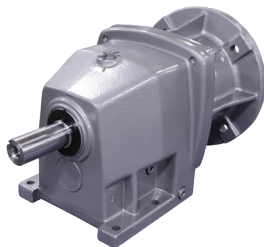

- ✓ Foot or flange mounted
- ✓ Long life, low-maintenance
- ✓ Optimum sealing
- ✓ UNICASE housing

Sizes: 11  
 Performance: 0.16 – 200 HP  
 Torque range: Up to 205,000 lb-in  
 Ratio: 2.76 – 14,340.31:1

## UNICASE parallel shaft gear units (Catalog: G1000)



- ✓ Foot, flange, or shaft mounted
- ✓ Hollow or solid shaft
- ✓ Compact design
- ✓ Cast iron or aluminum UNICASE housing

Sizes: 15  
 Performance: 0.16 – 200 HP  
 Torque range: Up to 680,000 lb-in  
 Ratio: 4.03 – 15,685.03:1

## UNICASE bevel gear units (Catalog: G1000)

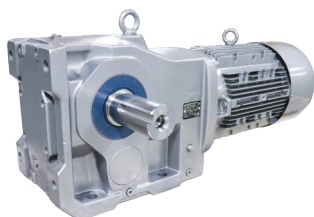

- ✓ Foot, flange, or shaft mounted
- ✓ Hollow or solid shaft
- ✓ UNICASE housing

Sizes: 11  
 Performance: 0.16 – 200 HP  
 Torque range: Up to 442,500 lb-in  
 Ratio: 8.04 – 13,432.68:1

### UNICASE worm gear units (Catalog: G1000)

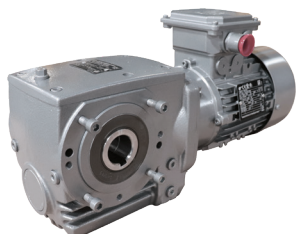

- ✓ Foot, flange, or shaft mounted
- ✓ UNICASE housing
- ✓ Hollow or solid shaft

Sizes: 6  
 Performance: 0.16 – 20 HP  
 Torque: Up to 27,350 lb-in  
 Ratio: 4.40 – 7,095.12:1

### NORDBLOC.1® 2-stage bevel gear units (Catalog: G1014)

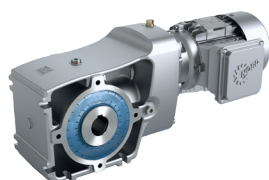

- ✓ Foot, flange, or shaft mounted
- ✓ Aluminum housing
- ✓ Hollow or solid shaft

Sizes: 6  
 Performance: 0.16 – 10 HP  
 Torque range: Up to 5,800 lb-in  
 Ratio: 3.03 – 70:1

### UNIVERSAL SI worm gear units (Catalog: G1035)

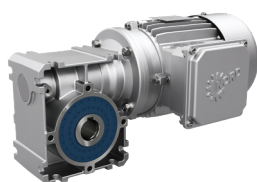

- ✓ Modular
- ✓ Universal mounting options
- ✓ Life-long lubrication
- ✓ NEMA and IEC versions

Sizes: 5  
 Performance: 0.16– 5.5 HP  
 Torque range: Up to 4,683 lb-in  
 Ratio: 5.00 – 3,000:1

### NORDAC® FLEX SK 200E variable frequency drives (Catalog: E3000)

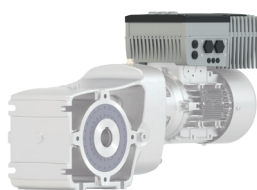

- ✓ Energy-saving function
- ✓ Integrated PLC
- ✓ Integrated POSICON positioning control

Sizes: 4  
 Voltage: 1~ 110 – 120 V, 1~ 200 – 240 V, 3~ 200 – 240 V, 3~ 380 – 500 V  
 Power range: 0.33 – 30 HP

### NORDAC® PRO SK 500E variable frequency drives (Catalog: E3000)



- ✓ Stand-alone operation
- ✓ 4 parameter sets

Sizes: 11  
 Voltage: 1~ 110 – 120 V, 1~ 200 – 240 V, 3~ 200 – 240 V, 3~ 380 – 480 V  
 Power range: 0.33 – 200 HP

# Ordering is Easy With myNORD Online Tools!



- ▶ Obtain drawing files direct from quote configuration
- ▶ Effortlessly select & configure customized drive solutions
- ▶ Create quotes with account-specific net pricing
- ▶ Order-specific documentation
- ▶ 24/7/365 order tracking
- ▶ Select and order spare parts

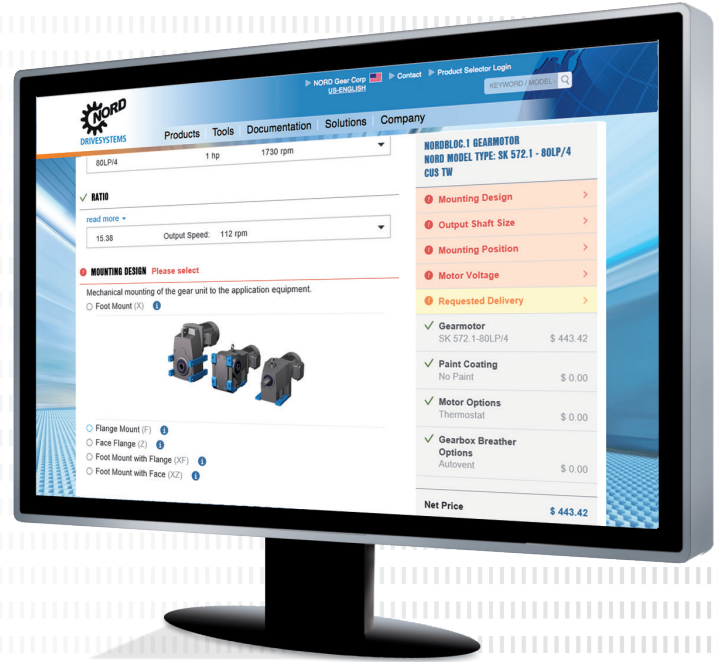

Register now at [myNORD.com](http://myNORD.com)!

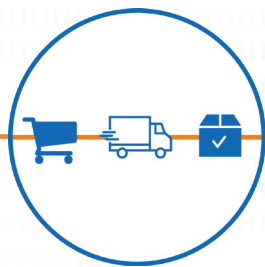
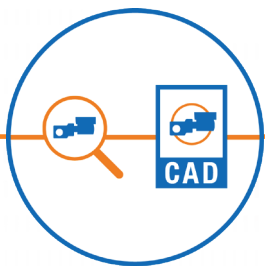

[www.nord.com](http://www.nord.com)

**NORD Gear Corporation - US**

Waunakee, WI  
800 NORD Drive  
Waunakee, WI 53597  
Tel. 888.314.6673  
info.us@nord.com

Corona, CA  
1180 Railroad St.  
Corona, CA 92882  
Tel. 888.314.6673  
info.us@nord.com

Charlotte, NC  
300E Forsyth Hall Dr.  
Charlotte, NC 28273  
Tel. 888.314.6673  
info.us@nord.com

**NORD Gear Limited - Canada**

Brampton, ON  
41 West Drive  
Brampton, ON L6T4A1  
Tel. 800.668.4378  
info.ca@nord.com

**NORD DRIVE SYSTEMS SA DE CV**

Queretaro, Mexico  
Av. Industria Textil B.6  
Parque Industrial PYME, Huimilpan  
QRO - Mexico 76950  
Tel. 52 442 688 7110  
info.mx@nord.com