

INTELLIGENT DRIVESYSTEMS, WORLDWIDE SERVICES



EAC



BU 0200 – en-US

**NORDAC FLEX (SK 200E ... SK 235E)**

Users Manual for Frequency Inverters



## Documentation

<b>Title:</b>	<b>BU 0200</b>								
<b>Order No.:</b>	<b>6072003</b>								
<b>Series:</b>	SK 200E								
<b>Device series:</b>	SK 200E, SK 210E, SK 220E, SK 230E, SK 205E, SK 215E, SK 225E, SK 235E								
<b>Device models:</b>	<table> <tr> <td><i>SK 2xxE-250-112-O ... SK 2xxE-750-112-O</i></td> <td>0.25 – 0.75 kW, 1~ 100-120 V, Out: 230 V</td> </tr> <tr> <td><i>SK 2xxE-250-123-A ... SK 2xxE-111-123-A</i></td> <td>0.25 – 1.1 kW, 1~ 200-240 V</td> </tr> <tr> <td><i>SK 2xxE-250-323-A ... SK 2xxE-112-323-A</i></td> <td>0.25 – 11.0 kW, 3~ 200-240 V <sup>1)</sup></td> </tr> <tr> <td><i>SK 2xxE-550-340-A ... SK 2xxE-222-340-A</i></td> <td>0.55 – 22.0 kW, 3~ 380-500 V <sup>2)</sup></td> </tr> </table> <p>1) Size 4 (5.5 – 11.0 kW) only in version SK 2x0E 2) Size 4 (11.0 – 22.0 kW) only in version SK 2x0E</p>	<i>SK 2xxE-250-112-O ... SK 2xxE-750-112-O</i>	0.25 – 0.75 kW, 1~ 100-120 V, Out: 230 V	<i>SK 2xxE-250-123-A ... SK 2xxE-111-123-A</i>	0.25 – 1.1 kW, 1~ 200-240 V	<i>SK 2xxE-250-323-A ... SK 2xxE-112-323-A</i>	0.25 – 11.0 kW, 3~ 200-240 V <sup>1)</sup>	<i>SK 2xxE-550-340-A ... SK 2xxE-222-340-A</i>	0.55 – 22.0 kW, 3~ 380-500 V <sup>2)</sup>
<i>SK 2xxE-250-112-O ... SK 2xxE-750-112-O</i>	0.25 – 0.75 kW, 1~ 100-120 V, Out: 230 V								
<i>SK 2xxE-250-123-A ... SK 2xxE-111-123-A</i>	0.25 – 1.1 kW, 1~ 200-240 V								
<i>SK 2xxE-250-323-A ... SK 2xxE-112-323-A</i>	0.25 – 11.0 kW, 3~ 200-240 V <sup>1)</sup>								
<i>SK 2xxE-550-340-A ... SK 2xxE-222-340-A</i>	0.55 – 22.0 kW, 3~ 380-500 V <sup>2)</sup>								

## Version list

Title, Date	Order number	Device software version	Remarks
<b>BU 0200</b> , March 2009	<b>6072003</b> / 1009	V 1.1 R1	First edition
Further revisions: March, December 2010, May 2011, October 2011, June 2014 An overview of the changes in the above mentioned editions can be found in the respective document.			
<b>BU 0200</b> , May 2015	<b>6072003</b> / 2115	V 2.0 R1	Among other things <ul style="list-style-type: none"> <li>• General corrections</li> <li>• Structural adaptations in the document (Chapter "Options and Accessories" broken down, content reorganized)</li> <li>• New parameters: P240 – 247, P330 – 334</li> <li>• Adaptation of parameters: P003, 100, 105, 108, 109, 110, 200, 219, 220, 300, 312, 313, 315, 316, 327, 401, 418, 420, 436, 480, 481, 502, 504, 535, 538, 550, 709, 740, 741, 745</li> <li>• Error messages E006, E007, E022 – 024, I000.6, I000.7</li> <li>• Operation of PM synchronous motors possible</li> <li>• PLC available</li> <li>• New display of scope of delivery/accessory overview</li> <li>• Revision of UL/cUL, plus inclusion of "group protection"</li> <li>• HTL rotary encoder, evaluation of zero track possible</li> </ul>

Title, Date	Order number	Device software version	Remarks
BU 0200, March 2016	6072003 / 1216	V 2.1 R0	Among other things <ul style="list-style-type: none"> <li>• General corrections</li> <li>• Structural adjustments to document</li> <li>• Removal of various descriptions for accessories (reference to additional documents → Technical Information)</li> <li>• Adaptation of parameters: P513, 504, 520, 550, 560, 703</li> <li>• Error messages I000.8, I000.9 added</li> <li>• Revision of section "UL/cUL", including for CSA: Voltage limitation filter (SK CIF) no longer required → Module removed from document</li> <li>• Installation description of toroidal core (ferrite) for improving EMC with size 4 added</li> <li>• AS Interface, addition of device versions ...-AXB and ...-AUX.</li> <li>• Updating of EC/EU conformity declarations</li> </ul>
BU 0200, December 2017	6072003 / 5117	V 2.1 R3	Among other things <ul style="list-style-type: none"> <li>• General corrections</li> <li>• Adaptation of safety information</li> <li>• Revision of warnings and hazard notes</li> <li>• Adaptation for ATEX, outdoor installation and braking resistors</li> <li>• Adapter kits for motor mounting and wall mounting kits now divided into versions for IP55 and IP66</li> <li>• Adaptation of parameters: P106, 107, 206, 208, 211, 212, 220, 330, 331, 400, 434, 546, 558, 709</li> </ul>
BU 0200, July 2018	6072003 / 3118	V 2.1 R4	Among other things <ul style="list-style-type: none"> <li>• General corrections</li> <li>• Adaptation of safety information</li> <li>• Adaptations for wall mounting kits</li> <li>• Adaptation for ATEX, outdoor installation and braking resistors</li> <li>• Addition of EAC EX</li> <li>• Adaptations for AS interface</li> <li>• Adaptation of parameters: P331, 332, 333, 555, 556, 557</li> <li>• Correction of standardization of setpoint and actual values</li> <li>• Motor data extended with 100 Hz characteristic curve</li> </ul>
BU 0200, December 2020	6072003 / 4920	V 2.2 R1	Among other things <ul style="list-style-type: none"> <li>• General corrections</li> <li>• New parameter P336, P780</li> <li>• Adaptation of parameters: P212, 245, 301, 504, 558, 556, 557</li> <li>• Error message E7.1</li> </ul>

**Table 1: Version List BU0200**

## Copyright notice

As an integral component of the device described here, this document must be provided to all users in a suitable form.

Any editing or amendment or other utilization of the document is prohibited.

## Publisher

### **Getriebebau NORD GmbH & Co. KG**

Getriebebau-Nord-Strasse 1 • 22941 Bargteheide, Germany • <http://www.nord.com/>

Tel. +49 (4532) 2890 • Fax +49 (4532) 289-2253

**Member of the NORD DRIVESYSTEMS Group**



## Table of Contents

<b>1</b>	<b>General</b> .....	<b>11</b>
1.1	Overview .....	13
1.2	Delivery .....	16
1.3	Scope of supply .....	17
1.4	Safety, installation and application information .....	22
1.5	Warnings and hazard information .....	26
1.5.1	Warnings and hazard information on the product.....	26
1.5.2	Warnings and hazard information in the document .....	27
1.6	Standards and approvals .....	27
1.6.1	UL and CSA approval.....	29
1.7	Model code/nomenclature.....	32
1.7.1	Nameplate .....	32
1.7.2	Variable Frequency Drive model code - basic device.....	33
1.7.3	Variable Frequency Drive model code – Connection unit.....	33
1.7.4	Model code for optional modules.....	34
1.7.5	Model code, connection unit for technology unit.....	35
1.7.6	Extensions model code .....	35
1.8	Output/size assignment.....	36
1.9	Version with IP55/IP66 rating.....	36
<b>2</b>	<b>Mounting and installation</b> .....	<b>38</b>
2.1	Mounting SK 2xxE.....	38
2.1.1	Installation of insulating plate – size 4 .....	40
2.1.2	Motor installation steps.....	41
2.1.2.1	Adapters for motor size .....	42
2.1.2.2	Dimensions, SK 2xxE mounted on motor .....	43
2.1.3	Wall mounting.....	44
2.1.3.1	Wall mounting kit without fan .....	44
2.1.3.2	Wall mounting kit with fan .....	46
2.1.3.3	Variable Frequency Drive mounting positions with wall mounting kit .....	48
2.2	Installation of optional modules .....	49
2.2.1	Optional slots on the device.....	49
2.2.2	Mounting of internal customer unit SK CU4-... (installation).....	51
2.2.3	Installation of external technology units SK TU4-... (attachment).....	52
2.3	Braking resistor (BW) - (from size 1).....	53
2.3.1	Internal braking resistor SK BRI4-.....	53
2.3.2	External braking resistor SK BRE4-... / SK BRW4-... / SK BREW4-.....	56
2.3.3	Braking resistor assignments.....	58
2.4	Electrical connection .....	59
2.4.1	Wiring guidelines .....	60
2.4.2	Electrical connection of power unit .....	61
2.4.2.1	Power supply connection (L1, L2(/N), L3, PE) .....	62
2.4.2.2	Motor cable .....	64
2.4.2.3	Braking resistor (+B, -B) – (from size 1) .....	64
2.4.2.4	Electromechanical brake .....	65
2.4.3	Electrical connection of the control unit .....	66
2.4.4	Power supply unit SK xU4-24V-... - connection example.....	73
2.5	Color and contact assignments for the incremental encoder (HTL) .....	75
2.6	Operation in potentially explosive environments .....	76
2.6.1	Operation in potentially explosive environments - ATEX zone 22 3D.....	77
2.6.1.1	Modification of the device for compliance with category 3D .....	77
2.6.1.2	Options for ATEX zone 22, category 3D .....	78
2.6.1.3	Maximum output voltage and torque reduction .....	80
2.6.1.4	Commissioning information .....	80
2.6.1.5	EU conformity declaration - ATEX .....	82
2.6.2	Operation in potentially explosive environments - EAC Ex.....	83
2.6.2.1	Modification of the device .....	83
2.6.2.2	Further information .....	84
2.6.2.3	EAC Ex Certificate .....	84
2.7	Outdoor installation .....	85

<b>3</b>	<b>Display, operation and options</b> .....	<b>86</b>
3.1	Control and parameterization options .....	87
3.1.1	Use of control and parameterization units .....	88
3.1.2	Connection of multiple devices to one parameterization tool .....	89
3.2	Optional modules .....	90
3.2.1	Internal customer units SK CU4-... (installation of modules) .....	90
3.2.2	External technology units SK TU4-... (module attachment) .....	92
3.2.3	Plug connector .....	95
3.2.3.1	Plug connectors for power connections .....	95
3.2.3.2	Plug connectors for control connection .....	97
3.2.4	Potentiometer adapter, SK CU4-POT .....	98
<b>4</b>	<b>Commissioning</b> .....	<b>100</b>
4.1	Factory settings .....	100
4.2	Selecting the operating mode for motor control .....	101
4.2.1	Explanation of the operating modes (P300) .....	101
4.2.2	Overview of control parameter settings .....	103
4.2.3	Motor control commissioning steps .....	104
4.3	Starting up the device .....	105
4.3.1	Connection .....	105
4.3.2	Configuration .....	106
4.3.2.1	Parameterization .....	106
4.3.2.2	DIP switches (S1) .....	107
4.3.2.3	DIP switches, analog input (only SK 2x0E) .....	109
4.3.2.4	Potentiometers P1 and P2 (SK 2x0E size 4 and SK 2x5E) .....	110
4.3.3	Plug-in EEPROM (memory module) .....	111
4.3.3.1	Replacing the plug-in EEPROM (memory module) .....	111
4.3.3.2	Copy function .....	112
4.3.3.3	Copy function DIP switches S1 – 6 "COPY" .....	112
4.3.4	Commissioning examples .....	114
4.3.4.1	SK 2x0E minimum configuration .....	114
4.3.4.2	SK 2x5E minimum configuration .....	115
4.4	Temperature sensors .....	117
4.5	AS interface (AS-i) .....	120
4.5.1	The bus system .....	120
4.5.2	Features and technical data .....	121
4.5.3	Bus structure and topology .....	122
4.5.4	Commissioning .....	123
4.5.4.1	Connection .....	123
4.5.4.2	Displays .....	126
4.5.4.3	Configuration .....	127
4.5.4.4	Addressing .....	129
4.5.5	Certificate .....	130
<b>5</b>	<b>Parameter</b> .....	<b>131</b>
5.1	Parameter overview .....	135
5.2	Description of parameters .....	138
5.2.1	Operating display .....	139
5.2.2	Basic parameter .....	141
5.2.3	Motor data/characteristic curve parameter .....	148
5.2.4	Control parameter .....	157
5.2.5	Control terminals .....	166
5.2.6	Additional parameters .....	188
5.2.7	Positioning .....	208
5.2.8	Informations .....	209
<b>6</b>	<b>Operating status messages</b> .....	<b>220</b>
6.1	Display of messages .....	221
6.2	Diagnostic LEDs on device .....	221
6.2.1	Diagnostic LEDs on SK 2x0E (size 1 ... 3) .....	222
6.2.2	Diagnostic LEDs on the SK 2x0E (size 4) and SK 4x5E .....	223
6.3	Messages .....	225
6.4	FAQ operational problems .....	234
<b>7</b>	<b>Technical Data</b> .....	<b>236</b>
7.1	General data for variable frequency drive .....	236
7.2	Electrical data .....	237

7.2.1	Electrical data 1~115 V.....	238
7.2.2	Electrical data 1~230 V.....	239
7.2.3	Electrical data 3~230 V.....	240
7.2.4	Electrical data 3~400 V.....	243
<b>8</b>	<b>Additional information .....</b>	<b>246</b>
8.1	Setpoint processing.....	246
8.2	Process controller .....	247
8.2.1	Process controller application example .....	248
8.2.2	Process controller parameter settings .....	249
8.3	Electromagnetic compatibility (EMC) .....	250
8.3.1	General Provisions .....	250
8.3.2	EMC evaluation .....	251
8.3.3	EMC of device .....	252
8.3.4	EU Declaration of Conformity .....	254
8.4	Reduced output power .....	255
8.4.1	Increased heat dissipation due to pulse frequency.....	255
8.4.2	Reduced overcurrent due to time .....	256
8.4.3	Reduced overcurrent due to output frequency.....	257
8.4.4	Reduced output current due to line voltage .....	258
8.4.5	Reduced output current due to the heat sink temperature.....	258
8.4.6	Reduced output current due to speed .....	259
8.5	Operation on the VFD circuit breaker.....	260
8.6	System bus .....	261
8.7	Energy efficiency.....	264
8.8	Motor data - characteristic curves .....	265
8.8.1	50 Hz characteristic curve .....	265
8.8.2	87 Hz characteristic curve (only 400 V devices).....	268
8.8.3	100 Hz characteristic curve (only 400 V devices).....	270
8.9	Standardization of setpoint/target values .....	272
8.10	Definition of setpoint and actual value processing (frequencies) .....	273
<b>9</b>	<b>Maintenance and servicing information.....</b>	<b>274</b>
9.1	Maintenance Instructions .....	274
9.2	Service notes .....	275
9.3	Abbreviations .....	276



## List of illustrations

Figure 1: Device with internal SK CU4-.....	15
Figure 2: Device with external SK CU4-.....	15
Figure 3: Nameplate .....	32
Figure 4: Connection unit size 1 ... 3.....	41
Figure 5: Connection unit size 4 .....	41
Figure 6: Example of motor size adaptation .....	42
Figure 7: SK 2xxE with wall mounting kit.....	44
Figure 8: SK TIE4-WMK-1-K (or. -2-K).....	45
Figure 9: SK TIE4-WMK-3.....	45
Figure 10: SK 2xxE with wall mounting kit.....	46
Figure 11: SK TIE4-WMK... (... 1-EX / 2-EX).....	46
Figure 12: SK 2xxE with wall mounting kit.....	47
Figure 13: SK TIE4-WMK-L ... ..	47
Figure 14: Variable Frequency Drive mounting positions with wall mounting kit.....	48
Figure 15: Optional slots on the connection unit.....	49
Figure 16: Jumpers for system adaptation .....	63
Figure 17: Connection example, power supply unit SK xU4-24V-.....	73
Figure 18: SK 2xxE (size 1), top view .....	86
Figure 19: SK 2xxE (size 1), internal view .....	86
Figure 20: Simple Box, handheld, SK CSX-3H.....	88
Figure 21: Parameter Box, handheld, SK PAR-3H.....	88
Figure 22: internal customer units SK CU4 ... (example).....	90
Figure 23: external technology units SK TU4-... (example).....	92
Figure 24: Examples of devices with connectors for power connection.....	95
Figure 25: Connection diagram SK CU4-POT, example SK 2x0E.....	98
Figure 26: Connection diagram and parameterization of SK CU4-POT, example SK 2x5E .....	99
Figure 27: Replacing the plug-in EEPROM .....	111
Figure 28: Connecting terminals AS-i, left size 1 – 3, right size 4.....	123
Figure 29: Diagnostic openings SK 2x0E (size 1 ... 3).....	222
Figure 30: Diagnostic openings SK 2x0E size 4 or SK 4x5E.....	223
Figure 31: Setpoint processing.....	246
Figure 32: Process controller flow diagram .....	247
Figure 33: Wiring recommendation.....	253
Figure 34: Heat losses due to pulse frequency .....	255
Figure 35: Output current due to line voltage .....	258
Figure 36: Derating factor "k" for motor installation (self-ventilated) .....	259
Figure 37: Energy efficiency due to automatic magnetization optimization .....	264
Figure 38: 50 Hz characteristic curve .....	265
Figure 39: 87 Hz characteristic curve .....	268
Figure 40: 100 Hz characteristic curve .....	270

## List of tables

Table 1: Version List BU0200.....	3
Table 2: Additional characteristics, size 1 ... 3.....	14
Table 3: Additional characteristics, size 4.....	14
Table 4: Warnings and hazard information on the product.....	26
Table 5: Standards and approvals.....	27
Table 6: Standards and approvals for explosion hazard environments.....	28
Table 7: Assignment of braking resistors to variable frequency drive.....	58
Table 8: Connection data.....	61
Table 9: external bus modules and IO extensions SK TU4- ... ..	93
Table 10: external modules with power supply unit SK TU4-24V- .../SK TU4-POT- .....	94
Table 11: external modules – maintenance switch SK TU4-MSW- .....	94
Table 12: Temperature sensors, adjustment.....	117
Table 13: AS- interface, connection of signal and supply lines.....	123
Table 14: FAQ operational problems.....	235
Table 15: EMC comparison between EN 61800-3 and EN 55011.....	251
Table 16: Overview according to product standard EN 61800-3 .....	253
Table 17: Overcurrent relative to time .....	256
Table 18: Overcurrent relative to pulse and output frequency .....	257
Table 19: Processing of setpoints and actual values in the variable frequency drive .....	273

## 1 General

The SK 2xxE series is based on the tried and tested NORD platform. The devices are characterized by their compact design and optimum control characteristics, and have uniform parameterization.

The devices have sensorless current vector control with a wide range of settings. All three-phase asynchronous motors that are suitable for inverter operation and permanent-magnet synchronous motors can be operated in combination with suitable motor models, which always provide an optimized voltage/frequency ratio. For the drive unit, this means very high starting and overload torques with constant speed.

The power range is from 0.25 kW to 22.0 kW.

This series of devices can be adapted to individual requirements by means of modular assemblies.

This manual is based on the device software as stated in the version list (see P707). If the variable frequency drive uses a different software version, this may cause differences. If necessary, the current manual can be downloaded from the Internet (<http://www.nord.com/>).

Additional descriptions are available for optional functions and bus systems (<http://www.nord.com/>).



### Information

#### Accessories

Changes may also be made to the accessories that are mentioned in the manual. Current details about these are included in separate data sheets which are listed at [www.nord.com](http://www.nord.com) under the heading *Documentation* → *Manuals* → *Electronic Drive Solutions* → *Techn. Info/Data Sheet*. The data sheets available at the date of publication of this manual are listed by name in the relevant sections (TI ...).

---

Installation directly on a motor is typical of this device series. Alternatively, optional accessories are also available for mounting the devices close to the motor, e.g. on the wall or on a machine frame.

The internal RS232 interface (access via RJ12 connection) can be used to access all parameters. The parameters are accessed via an optional Simple Box or Parameter Box, for example.

Parameter settings modified by the operator are backed up in the integrated, non-volatile memory of the device.

**Up to firmware version 1.4 R1** data was backed up in the pluggable EEPROM. The EEPROM then had to remain plugged in during operation.

In the simplest configuration for SK 2x0E, size 4 and the SK 2x5E units, even without the plugged-in EEPROM, all important parameters can be set using two potentiometers and eight DIP switches. LEDs are provided for operating status diagnostics. The use of a control module is therefore not absolutely necessary.

---

### Information

### Adaptation of parameter structure

With the software version change from **V1.1 R1 to V1.2 R0** of the variable frequency drive, the structure of individual parameters was changed ( Section 5 "Parameter"), e. g.: up to version V 1.1 R2 (P417) was a single parameter, but from version V1.2 R0 it was subdivided into two arrays ((P417) [-01] and [-02]).

When an EEPROM from a variable frequency drive with an earlier software version is plugged into a variable frequency drive with software version V1.2 or higher, the stored data is automatically converted to the new format. New parameters are stored with the default setting. This therefore provides correct functionality.

**However, it is not permissible to plug in an EEPROM (memory module) with a software version of V1.2 or higher into a variable frequency drive with a previous software version since this would lead to loss of all data.**

---

### Information

### DIP switch function change

The functional assignment of DIP switch S1-6 was changed in the software version change from **V1.4 R1 to V1.4 R2** of the variable frequency drive ( Section 4.3.2.2 "DIP switches (S1)"). The U/F function (changeover between ISD control and the U/F characteristic) was replaced with the COPY function (triggering of data exchange from the external EEPROM (memory module) to the internal EEPROM).

---

## 1.1 Overview



This manual describes two very similar basic versions of the SK 200E product family (NORDAC FLEX).

Wherever the *SK 2xxE* is mentioned below, this refers to information that applies to all devices in this family.

If the information applies exclusively to versions SK 205E/SK 215E/SK 225E/SK 235E, this is apparent from the designation *SK 2x5E*.

If the information only applies to versions SK 200E/SK 210E/SK 220E/SK 230E, this is recognizable from the designation *SK 2x0E*.

### Basic properties

- High starting torque and precise motor speed control setting by means of sensorless current vector control
- Can be installed directly on, or close to the motor.
- Permissible ambient temperature -25°C to 50°C (please refer to the technical data)
- Integrated EMC line filter for limit curve class A/category C2 or C3 (not with 115 V devices)
- Automatic measurement of the stator resistance and determination of precise motor data
- Programmable direct current braking
- Built-in brake chopper for 4-quadrant operation, optional braking resistors (internal/external)
- Separate temperature sensor input (TF+/TF-)
- Evaluation of an incremental encoder via digital inputs possible
- NORD system bus for linking modular additional modules
- Four separate parameter sets that can be changed over online
- 8x DIP switches for minimal configuration
- LEDs for diagnosis (SK 2x5E incl. DI/DO signal statuses)
- RS232/485 interface via RJ12 plug
- Plug-in data memory (EEPROM)
- **Integrated "POSICON" positioning control** ( [BU 0210](#))
- CANopen absolute value encoder evaluation via the NORD system bus
- Operation of *three-phase current asynchronous motors* (ASM) and *Permanent-Magnet Synchronous Motors* (PMSM)
- Integrated PLC ( [BU 0550](#))

Differences between the individual versions (SK 200E/SK 205E/... SK 235E) are summarized in the following table and will be described in this manual.

**Additional characteristics, sizes 1 ... 3**

Feature	200E	205E	210E	215E	220E	225E	230E	235E
Integrated 24 V power supply unit	x		x		x		x	
Optionally available 24 V power supply unit		x		x		x		x
Number of digital inputs (DIN)	4	4	3	3	4	4	3	3
Number of digital outputs (DO)	2	1	2	1	2	1	2	1
Number of analog inputs (AIN)	2		2		1		1	
Additional 2 potentiometers for minimal configuration		x		x		x		x
Electromechanical brake control		x		x		x		x
Safe pulse block (STO/SS1) ( <a href="#">BU0230</a> )			x	x			x	x
AS interface (4I/4O)					x	x	x	x

**Table 2: Additional characteristics, size 1 ... 3**

**Additional characteristics, size 4**

Feature	200E	210E	220E	230E
Integrated 24 V power supply unit	x	x	x	x
Number of digital inputs (DIN)	4	3	4	3
Number of digital outputs (DO)	2	2	2	2
Number of analog inputs (AIN)	2	2	1	1
Additional 2 potentiometers for minimal configuration	x	x	x	x
Electromechanical brake control	x	x	x	x
Safe pulse block (STO/SS1) ( <a href="#">BU0230</a> )		x		x
AS interface (4I/4O)			x	x

**Table 3: Additional characteristics, size 4**

### Optional modules

Optional modules are used to extend the functionality of the device.

These options are available as an installation variant, the so-called SK CU4-... customer unit, and also as an attachment variant, the so-called SK TU4-... technology unit. Apart from the mechanical differences, the installation and attachment variants also have some functional differences.

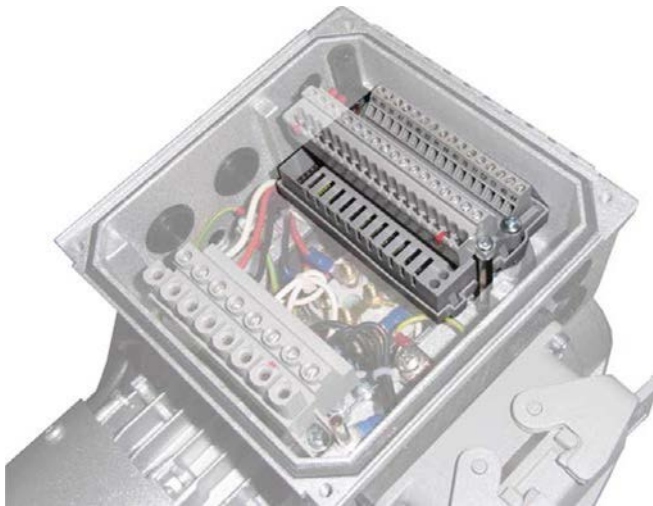

Figure 1: Device with internal SK CU4-...



Figure 2: Device with external SK CU4-...

#### *Attachment variant*

The **external technology unit (Technology Unit SK TU4-...)** is externally attached to the device and is therefore easy to access.

A technology unit basically requires the use of a suitable SK TI4-TU-... connection unit.

The power supply and signal lines are connected using the screw clamps of the connection unit. Depending on the version, additional connections for connectors (e.g. M12 or RJ45) may be available.

The optional wall mounting kit SK TIE4-WMK-TU also allows the technology units to be mounted away from the device.

#### *Built-in variant*

The **internal customer unit (Customer Unit, SK CU4-...)** is integrated in the device. The power supply and signal lines are connected using screw clamps.

The **SK CU4-POT** potentiometer adapter is an exception among the SK CU4 Modules since it is not integrated in the device but attached to it.

"Smart" optional modules and the device communicate via the system bus. Smart optional modules are modules with their own processor and communication technology as is the case with field bus modules, for example.

The variable frequency drive can manage the following options via its system bus:

- 1 x parameterization unit SK PAR-3H and (via an RJ12 connector)
- 1 x field bus option (e.g. Profibus DP), internal or external and
- 2 x I/O extension (SK xU4-IOE-...), internal and/or external
- 1 x CANopen absolute encoder

Up to 4 variable frequency drives with their appropriate options can be connected to a system bus.

## 1.2 Delivery

Check the device **immediately** after delivery/unpacking for transport damage such as deformation or loose parts.

If there is any damage, contact the carrier immediately and carry out a thorough assessment.

**Important! This also applies even if the packaging is undamaged.**



### 1.3 Scope of supply

## NOTICE





#### Defect in the device







Use of unapproved accessories and options (e.g. options from other device series (SK CSX-0) may result in defects of the interconnected components.









- Only use accessories and options which are explicitly intended for use with this device and stated in this manual.







- Standard version:*
- IP55 version of device (optionally IP66)
  - Operating instructions as PDF file on CD ROM including NORD CON, (PC parameterization software)





*Available accessories:*

	Designation	Example	Description
Control and parameterization options	Handheld parameterization units for temporary connection to the device		For commissioning, parameterization and control of the device. <b>SK PAR-3H, SK CSX-3H</b> (📖 Section 3.1.1 "Use of control and parameterization units")
	Handheld control units		For controlling the device, <b>Model SK POT- ...</b> (📖 Section 3.1.1 "Use of control and parameterization units")
	NORD CON MS Windows® - based software		For commissioning, parameterization and control of the device Refer to <a href="http://www.nord.com">www.nord.com</a> <b>NORD CON</b> (Free download)
Bus interface	Internal bus interfaces		Customer unit for installation device for: CANopen, DeviceNet, EtherCAT, Ethernet/IP, Powerlink, Profibus DP, Profinet IO, <b>Model SK CU4- ...</b> (📖 Section 3.2.1 "Internal customer units SK CU4-... (installation of modules)")
	External bus interfaces		Technology unit attached to the device or alternatively for wall mounting (wall mounting kit required) for: CANopen, DeviceNet, EtherCAT, Ethernet/IP, Powerlink, Profibus DP, Profinet IO, <b>Model SK TU4- ...</b> (📖 Section 3.2.2 "External technology units SK TU4-... (module attachment)")

<b>Braking resistors</b>	<b>Internal braking resistors</b>		Braking resistor installed in the device to divert regenerative energy from the drive system caused by conversion to heat. Regenerative energy arises during braking processes or the downward motion of loads, <b>Model SK BRI4- ...</b> (📖 Section 2.3.1 "Internal braking resistor SK BRI4-...")
	<b>External braking resistors</b>		Refer to: <i>Internal braking resistors</i> , but for attaching to the device <b>Model SK BRE4- ...</b>  (📖 Section 2.3.2 "External braking resistor SK BRE4-... / SK BRW4-... / SK BREW4-...")
<b>I/O expansions</b>	<b>Internal I/O expansion</b>		Customer unit installed in the device to extend the analog and digital inputs and outputs. <b>Model SK CU4-IOE...</b> (📖 Section 3.2.1 "Internal customer units SK CU4-... (installation of modules)")
	<b>Internal signal converter</b>		Customer unit installed in the device to convert bipolar analog signals to unipolar analog signals, e.g. digital signals on relays <b>Model SK CU4-REL- ...</b> (📖 Section 3.2.1 "Internal customer units SK CU4-... (installation of modules)")
	<b>External I/O extension</b>		Technology unit attached to the device or alternatively for wall mounting (wall mounting kit required) to extend the analog and digital inputs and outputs. <b>Model SK TU4-IOE- ...</b> (📖 Section 3.2.2 "External technology units SK TU4-... (module attachment)")
<b>Power supply units</b>	<b>Internal power supply units</b>		SK 2x5E: Power supply unit installed in the device to generate the 24 VDC control power. <b>Model SK CU4-24V- ...</b> (📖 Section 3.2.1 "Internal customer units SK CU4-... (installation of modules)")
	<b>External power supply units</b>		SK 2x5E: Technology unit attached to the device or alternatively for wall mounting (wall mounting kit required) to generate the 24 VDC control power. <b>Model SK TU4-24V- ...</b> (📖 Section 3.2.2 "External technology units SK TU4-... (module attachment)")

Wall mounting	Wall mounting kit for the device		Set for mounting the device, separate from the motor (e.g. to a wall). <b>Model SK TIE4-WMK-...</b> (📖 Section 2.1.3 "Wall mounting")
	Wall mounting kit for SK TU4-... modules		Set for mounting a technology unit, SK TU4-..., separate from the device (e.g. to a wall). <b>Model SK TIE4-WMK-TU</b> (📖 Section 3.2.2 "External technology units SK TU4-... (module attachment)")
Switches and potentiometers	Switch/potentiometer unit (L – OFF – R/0 – 10 V)		Customer unit attached to the device for ease of control of the device using 3-position switch and potentiometers <b>Model SK CU4-POT</b> (📖 Section 3.2.1 "Internal customer units SK CU4-... (installation of modules)")
	ATEX potentiometer (0 – 10 V)		Potentiometer with ATEX capability attached to the device for ease of control of the device <b>Model SK ATX-POT</b> (📖 Section 3.2.1 "Internal customer units SK CU4-... (installation of modules)")
	Potentiometer (0 – 10 V)		Potentiometer attached to the device for ease of control of the device <b>Model SK TIE4-POT</b> (📖 Section 3.2.1 "Internal customer units SK CU4-... (installation of modules)")
	Switch (L – OFF – R)		3-position switch attached to the device for ease of control of the device <b>Model SK TIE4-SWT</b> (📖 Section 3.2.2 "External technology units SK TU4-... (module attachment)")
	Maintenance switch (0 – I)		Technology unit attached to the device or alternatively for wall mounting (wall mounting kit required) for the safe insulation of the device from the AC power supply. <b>Model SK TU4-MSW- ...</b> (📖 Section 3.2.2 "External technology units SK TU4-... (module attachment)")
	Setpoint adjuster (L – 0 – R/0 – 100 %)		Technology unit attached to the device or alternatively for wall mounting (wall mounting kit required) for ease of control of the device using buttons and potentiometers, including power supply unit to generate a 24 VDC control power supply. <b>Model SK TU4-POT- ...</b> (📖 Section 3.2.2 "External technology units SK TU4-... (module attachment)")

<b>Plug connector</b>	<b>Power connection</b> (for power input, power output, motor output)		AC power connector attaching to the device to establish a detachable connection for supply lines (e.g. power supply line) <b>Model SK TIE4-...</b> (📖 Section 3.2.3.1 "Plug connectors for power connections")
	<b>Control line connection</b>		System connector (M12) attaching to the device to establish a detachable connection for control lines <b>Model SK TIE4-...</b> (📖 Section 3.2.3.2 "Plug connectors for control connection")
<b>Adapter</b>	<b>Adapter cable</b>		Various adapter cables ( <a href="#">Link</a> )
	<b>Mounting adapter</b>		Various adapter kits attached the device in different motor sizes (📖 Section 2.1.2.1 "Adapters for motor size")
	<b>EEPROM memory module adapter</b>		For data backups and parameterization of the <i>memory module</i> (external EEPROM) of the variable frequency drive, independently of the variable frequency drive <b>Type SK EPG-3H</b> ( <a href="#">Link</a> )
<b>Miscellaneous</b>	<b>Internal electronic brake rectifier</b>		Customer unit installed in the device for direct actuation of an electromechanical brake <b>Model SK CU4-MBR- ...</b> (📖 Section 3.2.1 "Internal customer units SK CU4-... (installation of modules)")

Software (Free download)	<b>NORDCON</b> <b>MS Windows®-based software</b>		For commissioning, parameterization and control of the device Refer to <a href="http://www.nord.com">www.nord.com</a> <a href="#">NORDCON</a>
	<b>ePlan macros</b>		Macros for producing electrical circuit diagrams Refer to <a href="http://www.nord.com">www.nord.com</a> <a href="#">ePlan</a>
	<b>Device master data</b>		Device master data/device description files for NORD field bus options <a href="#">NORD field bus files</a>
	<b>S7 standard modules</b> for PROFIBUS DP and PROFINET IO		Standard modules for NORD variable frequency drives Refer to <a href="http://www.nord.com">www.nord.com</a> <a href="#">S7_Files_NORD</a>
	<b>Standard modules for the TIA portal</b> for PROFIBUS DP and PROFINET IO		Standard modules for NORD variable frequency drives <i>Available on request.</i>

## 1.4 Safety, installation and application information

Before working on or with the device, please read the following safety instructions extremely carefully. Please pay attention to all other information in the device manual.

Non-compliance can result in serious or fatal injuries and damage to the device or its surroundings.

**These safety instructions must be kept in a safe place!**

### 1. General

Do not use defective devices or devices with defective or damaged housing or missing cover (e.g. blind plugs for cable inlets). Otherwise, there is risk of serious or fatal injuries caused by electric shock or bursting electrical components such as powerful electrolytic capacitors.

Unauthorized removal of covers, improper use, incorrect installation or operation brings about the risk of serious personal injury or material damage.

There may be live, bare, moving or rotating parts or hot surfaces during operation and depending on the degree of protection of the devices.

The device operates at dangerous voltages. Dangerous voltage may be present at the supply lines, terminal strips and PCBs of all connecting terminals (e.g. power input, motor connection) even if the device is not working or the motor is not rotating (e.g. caused by electronic disable, jamming of the drive or a short circuit at the output terminals).

The device is not equipped with a main power switch and therefore is always live when connected to the power supply. Therefore voltages may also be present in a connected motor at standstill.

Even if the drive unit has been disconnected from the line supply, a connected motor may rotate and possibly generate a dangerous voltages.

If you come into contact with dangerous voltages such as these, there is risk of electric shock which can lead to serious or fatal injuries.

The device and any power plug connectors must not be disconnected while a voltage is applied to the device. Failure to comply with this may cause arcing which, in addition to the risk of injury, also results in risk of damage or destruction of the device.

The fact that the status LED or other indicators are not illuminated does not indicate that the device has been disconnected from the power grid and is de-energized.

The heat sink and all other metal components can heat up to temperatures above 70°C.

Touching parts such as this can result in local burns to the body parts concerned (cooling times and clearance from neighboring components must be adhered to).

All work on the device such as transportation, installation, commissioning and maintenance must be carried out by qualified experts (observe IEC 364 or CENELEC HD 384 or DIN VDE 0100 and IEC 664 or DIN VDE 0110 and national accident prevention regulations). In particular, the general and regional installation and safety regulations for work on high-voltage systems (e.g. VDE) must be complied with as must the regulations concerning correct use of tools and the use of personal protection equipment.

When working on the device, make sure that no foreign bodies, loose parts, moisture or dust enter or remain in the device (risk of short circuit, fire and corrosion).

Additional information can be found in this documentation.

### 2. Qualified experts

For the purposes of these basic safety instructions, qualified personnel are persons who are familiar with the assembly, installation, commissioning and operation of this product and who have the relevant qualifications for their work.

Furthermore, the device and the associated accessories may only be installed and started up by qualified electricians. Electricians are persons who, because of their technical training and experience, have sufficient knowledge with regard to

- Switching on, switching off, isolating, grounding and marking power circuits and devices,
- Proper maintenance and use of protective devices in accordance with defined safety standards.

### **3. Correct purpose of use – general**

Variable Frequency Drives are devices for industrial and commercial systems that are used to operate three-phase asynchronous motors with squirrel-cage rotors and permanent-magnet synchronous motors (PMSM). These motors must be suitable for operation with variable frequency drives. Other loads must not be connected to the devices.

The devices are components intended for installation in electrical systems or machines.

Please refer to the nameplate and in the documentation for technical data and information about connection conditions, which must be complied with.

The devices may only be used for safety functions which are described and explicitly approved.

CE-marked devices meet the requirements of the Low-Voltage Directive 2014/35/EU. The aforementioned harmonized standards for the devices are used in the declaration of conformity.

#### **a. Supplement: Intended use within the European Union**

When installed in machines, startup of the devices (i.e. commencement of intended operation) is prohibited until it has been ensured that the machine meets the provisions of EC Directive 2006/42/EC (Machinery Directive). EN 60204-1 must also be complied with.

Commissioning (i.e. commencement of intended operation) is only permitted if the EMC directive (2014/30/EU) has been complied with.

#### **b. Supplement: Intended use outside the European Union**

Adhere to local and national regulations regarding the installation and commissioning of the device (see also "a) Supplement: Intended use within the European Union").

### **4. Phases of life**

#### ***Transport, storage***

Follow the instructions in the manual regarding transport, storage and correct handling.

Comply with the permissible mechanical and climatic ambient conditions (see Technical Data in the device manual).

If necessary, use suitable and adequately dimensioned means of transport (e.g. lifting gear, cable guides).

#### ***Installation and assembly***

Installation and cooling of the device must be carried out according to regulations in the corresponding documentation. Comply with the permissible mechanical and climatic ambient conditions (see Technical Data in the device manual).

Protect the device against inadmissible loads. In particular, prevent component deformation and/or modification of insulation distances. Avoid touching electronic components and contacts.

The device and its optional modules contain electrostatically sensitive components which can be easily damaged by incorrect handling. Electrical components must not be mechanically damaged or destroyed.

#### ***Electrical connection***

Ensure that the device and the motor are specified for the correct supply voltage.



Installation, maintenance and repair work must not be carried out unless the device has been de-energized and at least 5 minutes have elapsed since line power has been disconnected! (Due to charged capacitors, the device may continue to carry hazardous voltages for up to 5 minutes after line power has been disconnected). Before starting work it is essential to check by measurement that all contacts of the power plug connectors or terminals are de-energized.

Establish the electrical installation as per applicable regulations (e.g. cable cross-section, fuses, protective conductor connection). Please refer to the documentation or manual for the device for further instructions.

Information regarding EMC-compliant installation such as shielding, grounding, setup of filters and routing of cables can be found in the documentation for the device and in Technical Information [TI 80-0011](#). CE-marked devices must also comply with these instructions. The manufacturer of the system or machine is responsible for compliance with the limit values specified in EMC regulations.

In case of a fault, insufficient grounding may cause an electric shock with possibly fatal consequences if the device is touched.

The device may only be operated with effective ground connections which comply with local regulations for large leakage currents (> 3.5 mA). Please refer to Technical Information [TI 80-0019](#) for detailed information regarding connections and operating conditions.

Connection of the supply voltage may directly or indirectly set the device into operation. Contact with electrically live components will result in electric shock, possibly with fatal consequences.

Disconnect all poles of all power connections (e.g. power supply) at all times.

### ***Setup, troubleshooting and commissioning***

Comply with applicable national accident prevention regulations when working on live devices (e.g. BGV A3, formerly VBG 4).

The device's voltage supply may start up the device directly or indirectly, or touching electrically conducting components may cause an electric shock with possible fatal consequences.

Parameterize and configure the devices in such a way that does not cause any hazards.

Under certain setting conditions the device or the motor connected to it may start automatically when line power is switched on. A machine that it drives (press, chain hoist, roller, fan, etc.) may then make an unexpected movement. This may cause various injuries, including to third parties.

Before switching on line power, secure the danger area by warning and removing all persons from the danger area.

### ***Operation***

If necessary, install additional monitoring and protective equipment in systems in which the devices are installed according to applicable safety requirements (e.g. legislation concerning technical equipment, accident prevention regulations, etc.).

Keep all covers closed during operation.

Under certain setting conditions the device or the motor connected to it may start automatically when line power is switched on. A machine that it drives (press, chain hoist, roller, fan, etc.) may then make an unexpected movement. This may cause various injuries, including to third parties.

Before switching on line power, secure the danger area by warning and removing all persons from the danger area.

The device produces operation-related noises within the audible frequency range. These noises may cause long-term stress, discomfort and fatigue, with negative effects on concentration. The frequency range or the noise can be shifted to a less disturbing or almost inaudible range by adjusting the pulse frequency. However, this might result in derating (lower output) of the device.

### ***Maintenance, repair and decommissioning***



Installation, maintenance and repair work must not be carried out unless the device has been de-energized and at least 5 minutes have elapsed since line power has been disconnected! (Due to charged capacitors, the device may continue to carry hazardous voltages for up to 5 minutes after line power has been disconnected). Before starting work it is essential to check by measurement that all contacts of the power plug connectors or terminals are de-energized.

Please refer to the device manual for further information.

### ***Disposal***

Do not dispose of the product and its parts and accessories as domestic waste. At the end of its life, dispose of the product properly according to the local regulations for industrial waste. In particular, please note that this product contains integrated semiconductor circuits (PCBs and various electronic components, including high-power electrolytic capacitors). In case of incorrect disposal, there is a risk of formation of toxic gases, which may cause contamination of the environment and direct or indirect injuries (e.g. chemical burns). When it comes to high-power electrolytic capacitors, there is also a risk of explosion with the associated risk of injury.

### **5. Potentially explosive environment (ATEX, EAC Ex)**

In order to operate or carry out installation work in potentially explosive environments (ATEX, EAC Ex), the device must be approved and the relevant requirements and instructions in the device manual must be complied with.

Failure to comply can result in the ignition of an explosive atmosphere and fatal injuries.





- Only persons who are qualified, i.e. trained and authorized for all assembly, service, commissioning and operation activities in connection with explosive environments may work with the devices described here (including the motors, geared motors, any accessories and all connection equipment).
- Explosive concentrations of dust may cause explosions if ignited by hot or sparking objects. Such explosions may cause serious or fatal injuries to persons or severe material damage.
- The device must comply with the specifications of the "***Planning Guideline for Operating and Installation Instructions B1091***" [B1091-1](#).
- Only original parts which are approved for the device and for operation in an explosive environment (ATEX zone 22 3D, EAC Ex) must be used.
- **Repairs may only be carried out by Getriebebau NORD GmbH & Co. KG.**

## 1.5 Warnings and hazard information

Under certain circumstances, hazardous situations may occur in association with the variable frequency drive. Clear warnings and hazard information can be found in a suitable place on the product and in the relevant documentation to draw your attention explicitly to possible hazardous situations.

### 1.5.1 Warnings and hazard information on the product

The following warnings and hazard information are used on the product.

Symbol	Supplement to symbol <sup>1)</sup>	Meaning
	DANGER Device is live > 5 min after disconnecting line voltage	<p><b>⚠ Danger</b> <b>Electric shock</b></p> <p>The device contains powerful capacitors. Because of this, there may still be hazardous voltage for more than 5 minutes after disconnecting the main power supply.</p> <p>Before starting work on the device, check that all power contacts are de-energized by means of suitable measuring equipment.</p>
		It is essential to read the manual in order to prevent hazards!
		<p><b>⚠ CAUTION</b> <b>Hot surfaces</b></p> <p>The heat sink and all other metal components as well as the surfaces of plug connectors may heat up to temperatures in excess of 70°C.</p> <ul style="list-style-type: none"> <li>• Risk of injury due to local burns on contact.</li> <li>• Heat damage to adjacent objects</li> </ul> <p>Allow sufficient cooling time before starting work on the device. Check the surface temperatures with suitable measuring equipment. Maintain an adequate distance to adjacent components or provide protection against contact.</p>
		<p><b>NOTICE</b> <b>EDS</b></p> <p>The device contains electrostatically sensitive components which can be easily damaged by incorrect handling.</p> <p>Avoid all contact (indirect contact through tools or the like, or direct contact) with PCBs and their components.</p>



1) Text is written in English.

Table 4: Warnings and hazard information on the product

### 1.5.2 Warnings and hazard information in the document

The warnings and hazard information in this document are located at the beginning of the section which describes the actions which may result in the corresponding hazards.

The warnings and hazard information are classified as follows according to the ensuing risk as well as the probability and severity of the resulting injuries.

 <b>DANGER</b>	Indicates an immediate danger which may result in death or serious injury.
 <b>WARNING</b>	Indicates a possibly dangerous situation which may result in death or serious injury.
 <b>CAUTION</b>	Indicates a possibly dangerous situation which may result in slight or minor injuries.
<b>NOTICE</b>	Indicates a possibly harmful situation which may cause damage to the product or the environment.

### 1.6 Standards and approvals

All devices of the entire series comply with the standards and directives listed below.







Approval	Directive	Applicable standards	Certificates	Label
CE (European Union)	Low Voltage 2014/35/EU	EN 61800-5-1	C310700, C310401	
	EMC 2014/30/EU	EN 60529 EN 61800-3		
	RoHS 2011/65/EU	EN 50581		
UL (USA)		UL 61800-5-1	E171342	
CSA (Canada)		C22.2 No.274-13	E171342	
RCM (Australia)	F2018L00028	EN 61800-3	133520966	
EAC (Eurasia)	TR CU 004/2011, TR CU 020/2011	IEC 61800-5-1 IEC 61800-3	EAЭС N RU Д- DE.HB27.B.02727/ 20	

Table 5: Standards and approvals

Devices which are configured and approved for use in explosion hazard areas (📖 Section 2.6 "Operation in potentially explosive environments "), comply with the following directives or standards.

Approval	Directive	Applicable standards	Certificates	Label
ATEX (European Union)	ATEX 2014/34/EU	EN 60079-0 EN 60079-31	C432710	
	EMC 2014/30/EU	EN 61800-5-1 EN 60529		
	RoHS 2011/65/EU	EN 61800-3 EN 50581		
EAC Ex (Eurasia)	TR CU 012/2011	IEC 60079-0 IEC 60079-31	TC RU C-DE.AA87.B.01109	

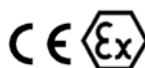
**Table 6: Standards and approvals for explosion hazard environments**

### 1.6.1 UL and CSA approval

#### File No. E171342

The categorization of protective devices approved by the UL according to United States Standards for the devices described in this manual is listed below with essentially the original wording. Please refer to the section "Electrical Data" in this manual for the categorization of individually relevant fuses or circuit breakers.

All devices are equipped with motor overload protection.

( Section 7.2 "Electrical data")

---

#### **Information**

##### **Group fuse protection**

The devices can be protected as a group via a common fuse (details below). Adhere to total current specifications and use correct cables and cable cross-sections when doing this. If the device/devices is/are being installed close to the motor, this also applies to the motor cable.

---

##### **UL/CSA conditions according to the report**

---

#### **Information**

"Integral solid state short circuit protection does not provide branch circuit protection. Branch circuit protection must be provided in accordance with manufacturer instructions, the National Electric Code and any additional local codes."

"Use 80°C Copper Conductors Only." (size 1 – 3)

"Use 60/75°C copper field wiring conductors." (size 4)

„These products are intended for use in a pollution degree 2 environment“

"The device has to be mounted according to the manufacturer instructions."

"For NFPA79 applications only"

---

**i Information**

**Internal Break Resistors (PTCs)**

Alternate - internal brake resistors, optional for drives marked for USL only (not for Canada), Unlisted Component NMTR3, manufactured by Getriebebau:

	Usage	Cat. No.
1	FS1-112, FS2-112, FS1-123, FS2-123	BRK-100R0-10-L or- M alternate PLR or PLRC100.61.41 100R 100W
2	FS1-323, FS2-323	BRK-200R0-10-L or- M alternate PLR or PLRC100.61.41 200R 100W
3	FS1-340	BRK-400R0-10-L or- M alternate PLR or PLRC100.61.41 400R 100W
4	FS3-323	BRM-100R0-10-L or- M alternate PLR or PLRC200.70.51 100R 200W
5	FS2-340, FS3-340	BRM-200R0-10-L or- M alternate PLR or PLRC200.70.51 200R 200W
6	-551-323	1x BRQ-47R0-10-L or- M alternate PLR or PLRC300.70.61 47R 300W
7	-751-323	1x BRQ-47R0-10-L or- M alternate PLR or PLRC300.70.61 47R 300W
8	-112-323	2x BRQ-47R0-10-L or- M alternate PLR or PLRC300.70.61 47R 300W
9	-112-340	1x BRQ-100R-10-L or- M alternate PLR or PLRC300.70.61 100R 300W
10	-152-340	1x BRQ-100R-10-L or- M alternate PLR or PLRC300.70.61 100R 300W
11	-182-340	2x BRQ-100R-10-L or- M alternate PLR or PLRC300.70.61 100R 300W
12	-222-340	2x BRQ-100R-10-L L or- M alternate PLR or PLRC300.70.61 100R 300W

Size	valid	description
1 - 3	For 240 V for 1 phase models or 500V for 3 phase models only:	<p>"Suitable For Use On A Circuit Capable Of Delivering Not More Than 65 000 rms Symmetrical Amperes, ____ Volt maximum",</p> <p>"When Protected by Circuit Breaker (inverse time trip type) in accordance with UL 489, rated ____ Amperes, and ____Volts", as listed in <sup>1)</sup>.</p>
	For 120 V, 240 V, 400 V, 500 V models only:	<p>"Suitable For Use On A Circuit Capable Of Delivering Not More Than 100 000 rms Symmetrical Amperes, ____ Volts Maximum" and minimum one of the two following alternatives.</p> <p>When used together with Accessory SK TU4-MSW:</p> <p>"Suitable For Use On A Circuit Capable Of Delivering Not More Than 10 000 rms Symmetrical Amperes, ____ Volts Maximum" and minimum one of the two following alternatives.</p> <p>1. "When Protected by Fuses manufactured by Bussmann, type ____", as listed in<sup>1)</sup>.</p> <p>2. "When Protected by class RK5 Fuses or faster or when Protected by High-Interrupting Capacity, Current Limiting Class CC, G, J, L, R, T, etc. Fuses, rated ____ Amperes, and ____ Volts", as listed in <sup>1)</sup>.</p>
	<b>Motor group installation (Group fusing):</b>	<p>"Suitable for motor group installation on a circuit capable of delivering not more than 100 000 rms symmetrical amperes, 500 V max" "When Protected by class RK5 Fuses or faster, rated 30_Amperes"</p> <p>"Suitable for motor group installation on a circuit capable of delivering not more than 100 000 rms symmetrical amperes, 500 V max" "When Protected by High-Interrupting Capacity, Current Limiting Class CC, G, J, L, R, T, etc. Fuses rated 30 Amperes"</p> <p>"Suitable for motor group installation on a circuit capable of delivering not more than 10 000 rms symmetrical amperes, 500 V max" "When Protected by Circuit Breaker (inverse time trip type) in accordance with UL 489, rated 30 Amperes and 500 Volts min"</p>
	<b>differing data CSA:</b>	<p>If device is used for Canadian market and bears the cUL Listing mark: "For Canada SCCR is limited to 5 000 rms Symmetrical Amperes.".</p> <p>Marking not required for UL only marked devices.</p>
4	Models -551-323-A; -751-323-A; -112-323-A only:	<p>"Suitable For Use On A Circuit Capable Of Delivering Not More Than 100 000 rms Symmetrical Amperes, 240 Volts Maximum When Protected By High-Interrupting Capacity, Current Limiting Type Fuses such as Class CC, G, J, L, R, T, etc., rated 300V/60A."</p> <p>"Suitable For Use On A Circuit Capable Of Delivering Not More Than 10 000 rms Symmetrical Amperes, 240 Volts Maximum When Protected By A Circuit Breaker Having An Interrupting Rating Not Less Than 10 000 rms Symmetrical Amperes, 300 Volts Maximum."</p>
	Models -112-340-A; -152-340-A; -182-340-A; -222-340-A only:	<p>"Suitable For Use On A Circuit Capable Of Delivering Not More Than 100 000 rms Symmetrical Amperes, 500 Volts Maximum When Protected By High-Interrupting Capacity, Current Limiting Type Fuses such as Class CC, G, J, L, R, T, etc., rated 600A/60A."</p> <p>"Suitable For Use On A Circuit Capable Of Delivering Not More Than 10 000 rms Symmetrical Amperes, 500 Volts Maximum When Protected By A Circuit Breaker Having An Interrupting Rating Not Less Than 10 000 rms Symmetrical Amperes, 600 Volts Maximum."</p>

1)  7.2

### 1.7 Model code/nomenclature

Unique model codes have been defined for the individual modules and devices. These provide individual details about the device model and its electrical data, degree of protection, mounting variant and special versions. A distinction is made between the following groups:

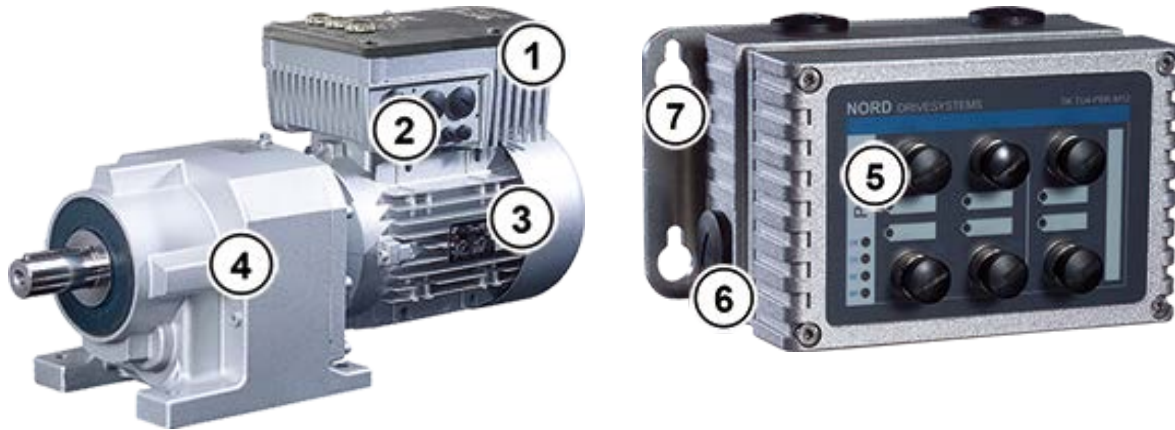

1	Variable Frequency Drive
2	Connection unit
3	Motor
4	Gear unit

5	Optional module
6	Connection unit
7	Wall mounting kit

#### 1.7.1 Nameplate

Please refer to the nameplate for all information relevant to the device, including information about device identification.

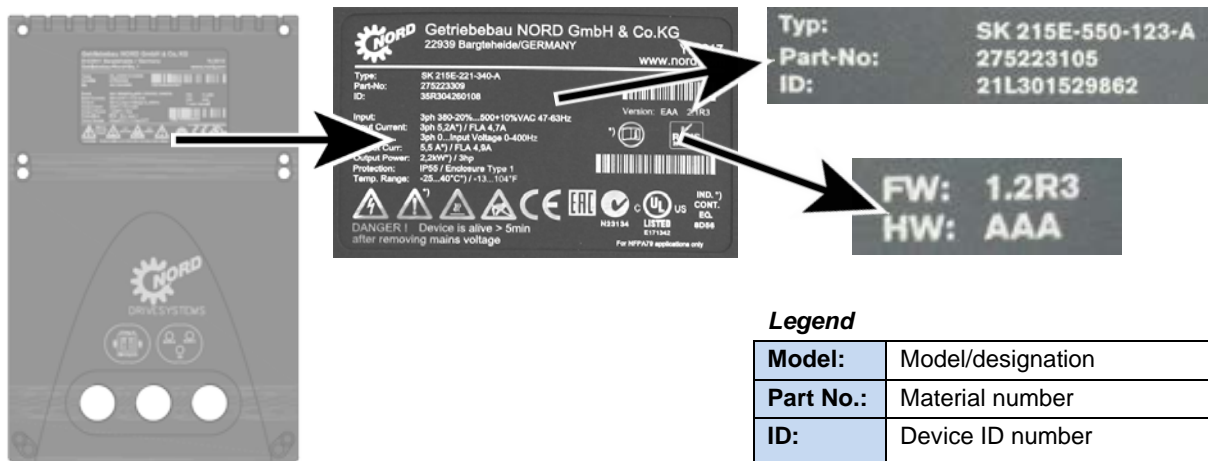
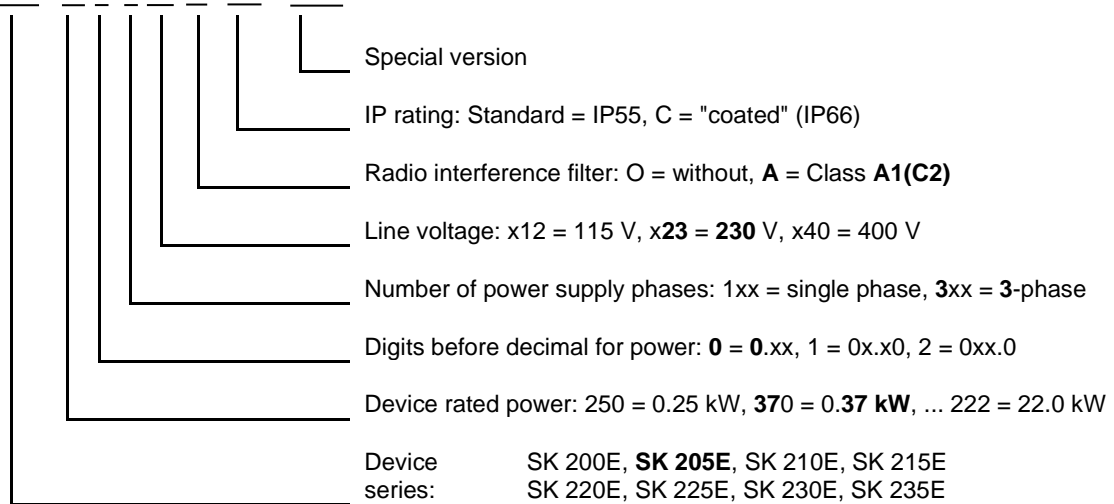

Figure 3: Nameplate



### 1.7.2 Variable Frequency Drive model code - basic device

SK 205E-370-323-A (-C) (-xxx)



(...) Options, only implemented if required.

### 1.7.3 Variable Frequency Drive model code – Connection unit

Sizes 1 to 3

SK TI4-1-205-1 (-C-EX)

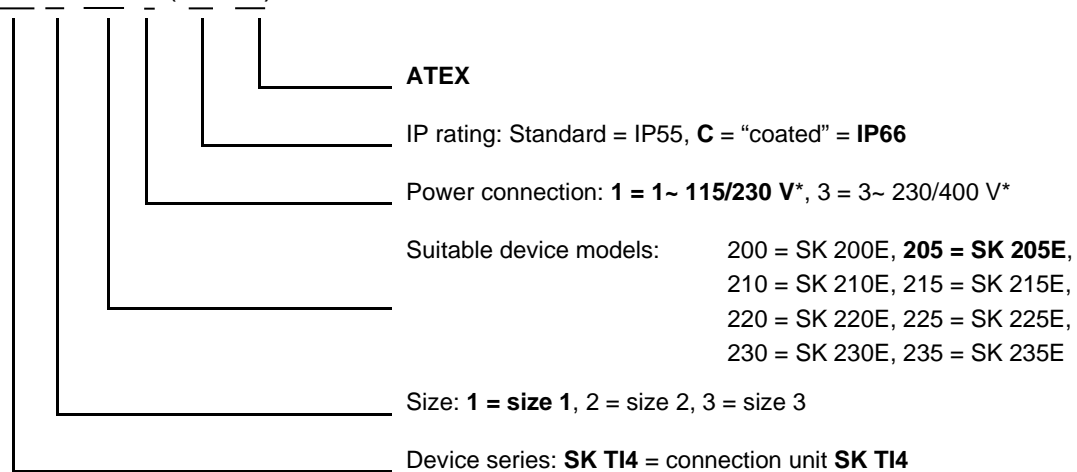

\*) The voltage depends on the variable frequency drive used. Please refer to the technical data as well.

(...) Options, only implemented if required.

Size 4

**SK TI4-4-200-340 (-C)**

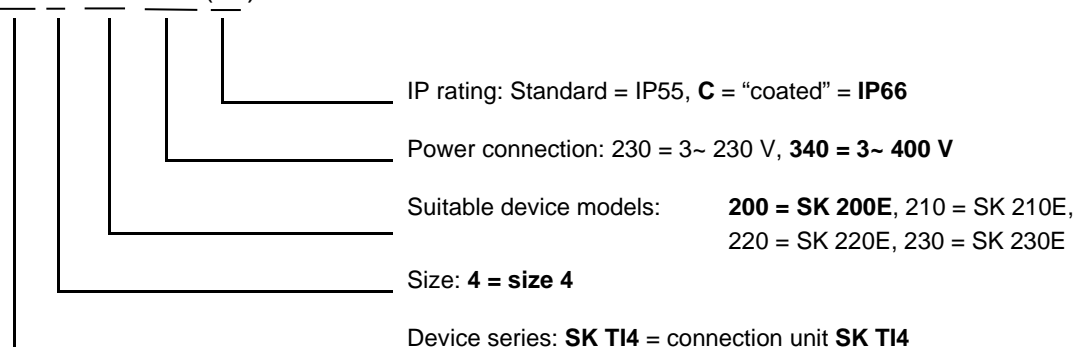

(...) Options, only implemented if required.

### 1.7.4 Model code for optional modules

**For bus modules or I/O extension**

**SK TU4-CAO (-C-M12)**

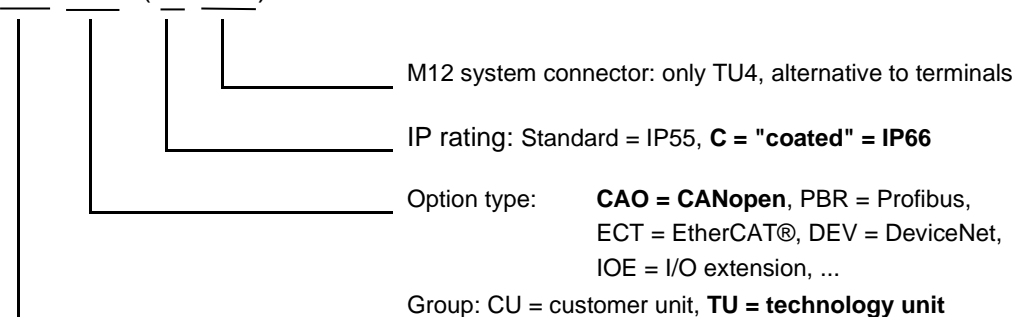

(...) Options, only implemented if required.

**For power supply unit or "PotiBox" potentiometer modules.**

**SK TU4-24V-123-B (-C)**

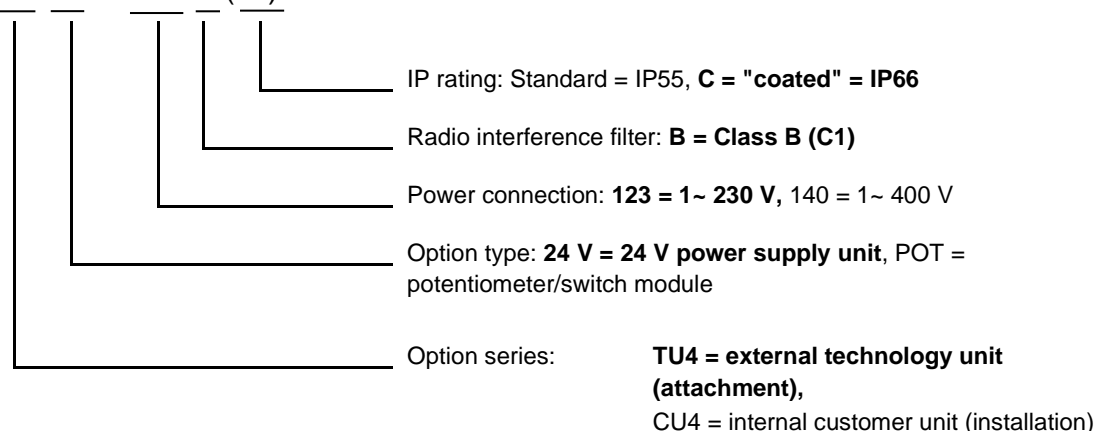

(...) Options, only implemented if required.

1.7.5 Model code, connection unit for technology unit

SK TI4-TU-BUS (-C)

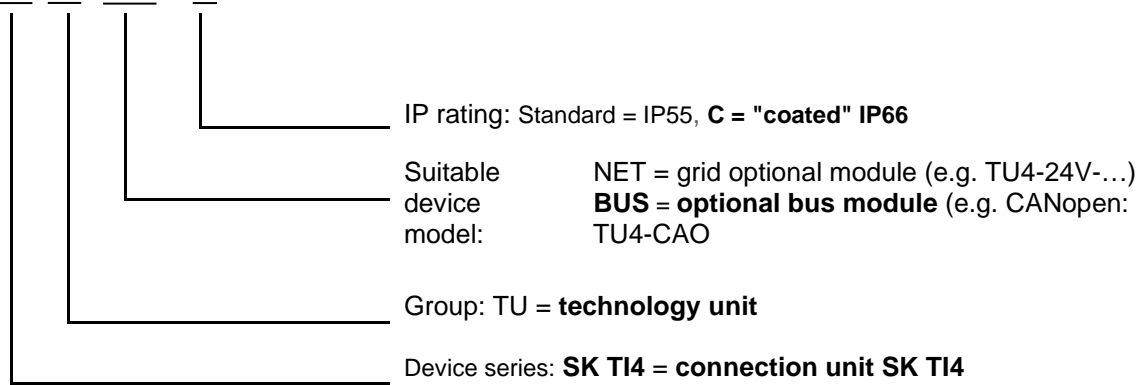

(...) Options, only implemented if required.

1.7.6 Extensions model code

SK TIE4-WMK-1 (-C- ...)

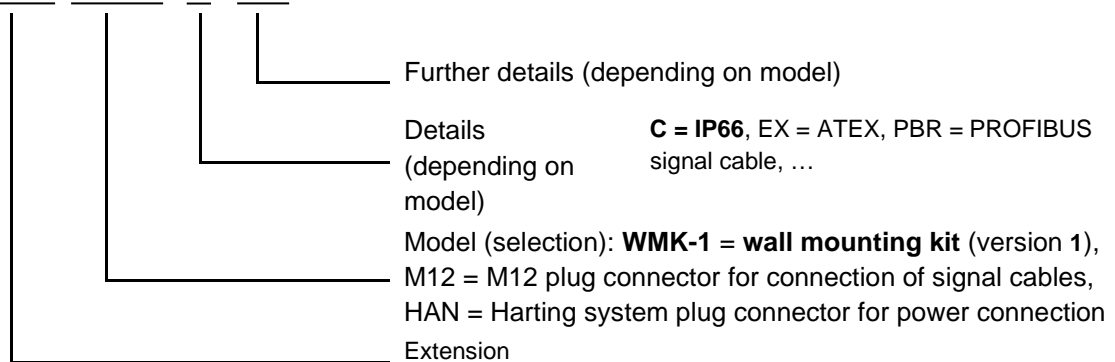

## 1.8 Output/size assignment

Size	AC power supply assignment SK 2xxE			
	1~ 110 - 120 V <sup>1)</sup>	1~ 200 – 240 V <sup>2)</sup>	3~ 200 – 240 V	3~ 380 – 500 V
Size 1	0.25 ... 0.37 kW	0.25 ... 0.55 kW	0.37 ... 1.1 kW	0.55 ... 2.2 kW
Size 2	0.55 ... 0.75 kW	0.75 ... 1.1 kW	1.5 ... 2.2 kW	3.0 ... 4.0 kW
Size 3	-	-	3.0 ... 4.0 kW	5.5 ... 7.5 kW
Size 4 <sup>3)</sup>	-	-	5.5 ... 11.0 kW	11.0 ... 22.0 kW

1) only available as SK 2x5E model

2) only available as SK 2x0E model in size 1

3) only available as SK 2x0E model

## 1.9 Version with IP55/IP66 rating

The SK 2xxE is available in IP55 (standard) or IP66 (optional). The additional modules are available in IP55 (standard) or IP66 (optional) rating.

A degree of protection that differs from the standard (IP66) must always be specified in the order when ordering!

There are no restrictions or differences in terms of functionality in the aforementioned degrees of protection. The model designation is extended accordingly in order to distinguish between the degrees of protection.

e.g. SK 2xxE-221-340-A-C

### Information

### Cable routing

For all versions, make sure that the cables and cable screw connections at a minimum comply with the degree of protection of the device and attachment regulations and are carefully matched. Insert the cables so that water is deflected away from the device (if necessary, use loops). This is essential to ensure that the required degree of protection is maintained.

#### IP55 version:

The IP55 version is the **standard** version. The two installation types *motor-mounted* (fitted onto the motor) and *close to the motor* (fitted to the wall bracket) are available in this version. All connection units, technology units and customer units are also available for this version.

#### IP66 version:

The IP66 version is a modified **option** of the IP55 version. Both installation types (*motor-integrated*, *close to the motor*) are also available for this version. The modules available to the IP66 design (connection units, technology units and customer units) have the same functionalities as the corresponding IP55 design modules.

---

**i Information**

**IP66 special measures**

The modules for the IP66 version are identified by an additional "-C" in the model code and were modified with the following special measures:

- Impregnated PCBs,
- Powder coating RAL 9006 (white aluminum) for housing,
- Modified blank screw caps (UV-resistant),
- Diaphragm valve for pressure compensation in the event of temperature changes,
- Low-pressure test.
  - A free M12 screw connection is required for low-pressure testing. A diaphragm valve is inserted here after successful testing. This screw connection is therefore no longer available for the cable inlet.

---

If the variable frequency drive needs to be retrofitted, i.e. the drive unit (inverter pre-attached to motor) is not entirely purchased from NORD, the diaphragm valve is supplied in the accessories kit with the variable frequency drive. The valve must be professionally installed on site by the system installer (**note:** the valve must be installed in a location that is as high as possible in order to avoid contact with accumulated moisture, e.g. standing water due to condensation).

---

**i Information**

**"SK 2xxE-...-C" devices, size 4**

Variable Frequency Drives, size 4, could also be delivered up to week of manufacture 38/2012 (up to ID No.: 38M...) as "coated" versions "-C" *but they only comply with IP55 because of the integrated fan.* **From ID No.: 39M.... these devices are also compliant with IP66.**

"SK 2xxE-...-C" devices with output of 5.5 kW and 7.5 kW (230 V), and 11 kW and 15 kW (400 V) **from ID No.: 28M... compliant with IP66.**

---

**i Information**

**Diaphragm valve**

The diaphragm valve (accessories kit with the IP66 version of the variable frequency drive connection unit) enables the compensation of pressure differences between the inside of the variable frequency drive and its environment and also prevents the entry of moisture. If it is mounted in an M12 screw gland of the inverter connection unit, make sure that the diaphragm valve does not come into contact with standing water.

---

## 2 Mounting and installation

### 2.1 Mounting SK 2xxE

The devices are available in various sizes depending on their output. They can be mounted on the terminal box of a motor or in its immediate vicinity.

Motor-mounted version



Wall-mounted version



When a complete drive unit (gear unit + motor + SK 2xxE) is delivered, the device is always fully installed and tested.

#### **i** Information

#### Device version IP6x

IP6x-compliant devices must be installed by NORD since special measures have to be taken. IP6x components that are retrofitted on site cannot guarantee this degree of protection.

The SK 2xxE is connected to the motor or the wall mounting kit using the size that is suitable for the SK TI4-... connection unit. The connection unit can also be ordered separately for subsequent mounting on an existing motor or to replace a different motor-mounted variable frequency drive.

The **Connection Unit SK TI4** module includes the following components:

- Cast housing, seal (already glued in) and insulation plate
- Power terminal block in accordance with line power connection
- Control terminal block in accordance with SK 2xxE version
- Screw kit for mounting on the motor and terminal blocks
- Ready-made cables for motor and PTC thermistor connection
- *Size 4 only:* From hardware status "EAA" (variable frequency drive) or "EA" (connection unit) toroidal core (ferrite) with fastening material

### Information

---

### Output derating

The devices require **sufficient ventilation** to protect against overheating. Failure to do so will result in a derating of the variable frequency drive. Ventilation is affected by the type of installation (motor mounting, wall mounting) or, with motor mounting, the air flow of the motor fan (continuous slow speed → lack of cooling).

Insufficient cooling can result in derating of 1-2 rating classes during S1 operation, for example, which can only be compensated for by using a nominally bigger device.

Details concerning derating and possible ambient temperatures, and other details ( Section 7.2 "Electrical data").

---



### 2.1.1 Installation of insulating plate – size 4

As of hardware status EAA of the variable frequency drive (suitable connection unit hardware status EA), a toroidal core must be fitted to the insulating plate (motor terminal cover). The toroidal core and the required fastening materials are included in the scope of delivery of the connection unit.

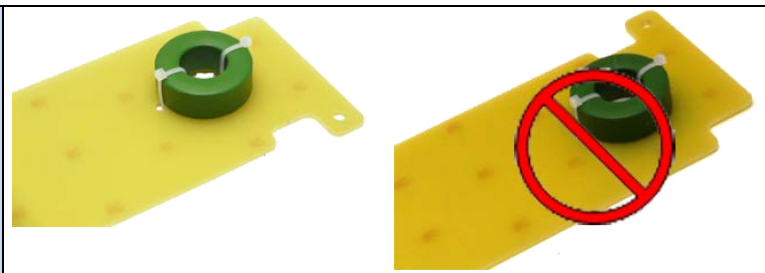
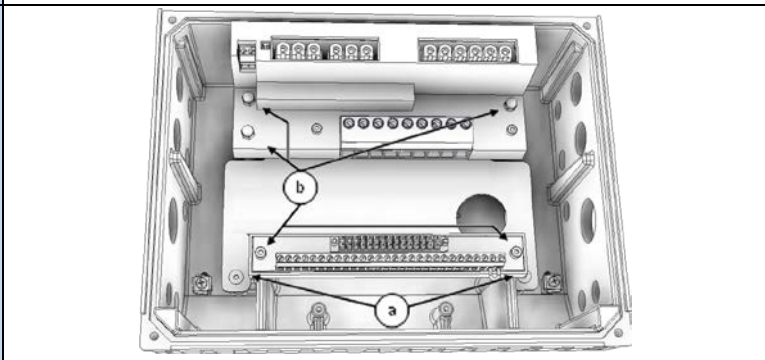
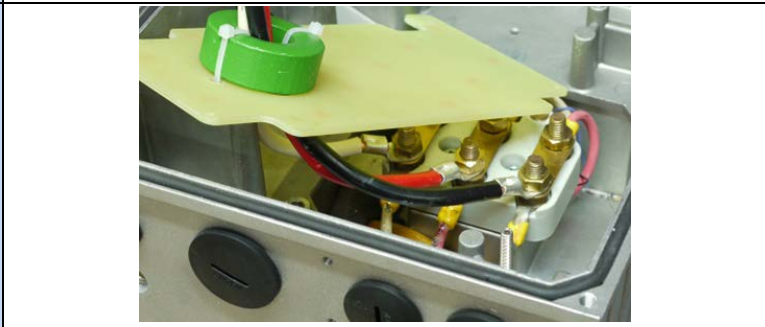

The toroidal core is required to ensure that EMC requirements are met.

#### Assembly sequence

<p>1 Secure toroidal core with cable ties as shown in the figure to the left (pay attention to insulating plate alignment).</p>	
<p>2 Remove terminal blocks (b).</p>	
<p>3 Connect wiring harness (motor cable) and lead through the toroidal core attached to the insulating plate.</p>	
<p>4 Wire motor cable to connecting terminals U – V – W of the relevant terminal block.</p>	
<p>5</p> <ul style="list-style-type: none"> <li>• Mount insulating plate (see illustration in step 2 – (a)).</li> <li>• Mount terminal blocks (see illustration in step 2 – (b)).</li> </ul>	



### 2.1.2 Motor installation steps

1. If necessary, remove the original terminal box from the NORD motor so that only the base of the terminal box and the motor terminal block remain.
2. Place the bridges for the correct motor circuit on the motor terminal block and connect the ready-made cables for motor and PTC thermistor connections to the respective connection points on the motor.
3. Mount the connection unit on the terminal box base of the NORD motor using the existing screws and gasket as well as the enclosed toothed/contact washers. When doing this, align the housing so that the rounded side is facing in the direction of the A end shield of the motor. Carry out mechanical adaptation using the adapter kit (see 2.1.2.1 "Adapters for motor size"). In general, check whether motors made by other manufacturers can be connected.

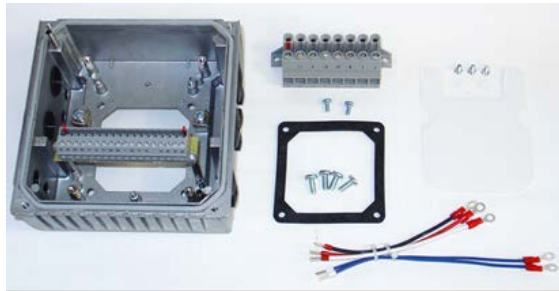

Figure 4: Connection unit size 1 ... 3



Figure 5: Connection unit size 4

4. Fasten insulating plate above the motor terminal block.
  - Size 4: Fasten toroidal core to insulating plate (see Section 2.1.1 "Installation of insulating plate – size 4").

Screw on power terminal block above this using 2x M4x8 screws and the plastic washers (size 4: 3x M4 cap nuts).

5. Make electrical connections. Use screwed connections appropriate for cable cross-section for the cable entry of the connecting cable.
6. Place the variable frequency drive on the connection unit. When it comes to sizes 1 to 3, pay special attention to the correct contacting of the PE pins. These are located diagonally in 2 corners of the variable frequency drive and the connection unit.

In order to ensure that the degree of protection for which the device is intended is achieved, make sure that all fastening screws that attach the variable frequency drive to the connection unit are tightened crosswise, step by step and at the torques indicated in the table below.

The cable screw connections used at a minimum must correspond to the degree of protection of the device.



Size SK 2xxE	Screw size	Tightening torque
Size 1	M5 x 45	2.0 Nm ± 20%
Size 2	M5 x 45	2.0 Nm ± 20%
Size 3	M5 x 45	2.0 Nm ± 20%
Size 4	M6 x 20	2.5 Nm ± 20%

### 2.1.2.1 Adapters for motor size

In some cases, the terminal box attachments are different for different motor sizes. Therefore, it may be necessary to use adapters to mount the device.

In order to ensure the maximum IPxx rating of the device for the entire unit, all elements of the drive unit (e.g. motor) must correspond to at least the same degree of protection.

#### **i** Information

#### Third-party motors

Check the adaptability of motors from other manufacturers individually!

Please refer to [BU0320](#) for information about converting a drive to the device.

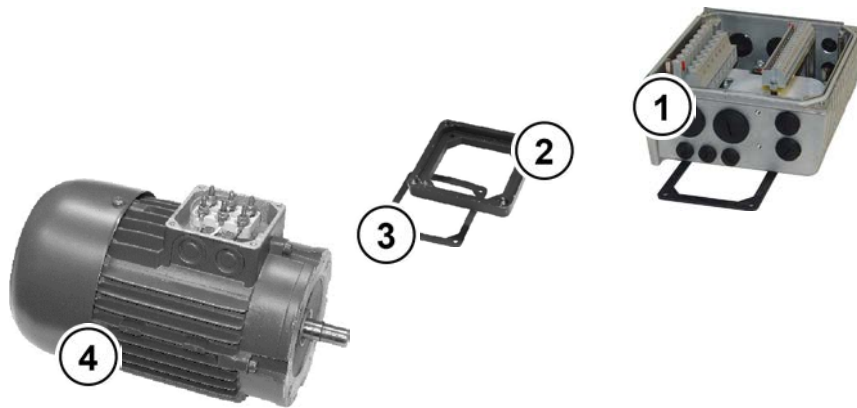

- 1 Connection unit SK T14
- 2 Adapter plate
- 3 Gasket
- 4 Motor, size 71

Figure 6: Example of motor size adaptation

NORD motor sizes	Add-on SK 2xxE Size 1	Add-on SK 2xxE Size 2	Add-on SK 2xxE Size 3	Add-on SK 2xxE Size 4
Size 63 – 71	with adapter kit I	with adapter kit I	Not possible	Not possible
Size 80 – 112	Direct mounting	Direct mounting	with adapter kit II	Not possible
Size 132	Not possible	Not possible	Direct mounting	with adapter kit III
Size 160-180	Not possible	Not possible	Not possible	Direct mounting

#### Overview of adapter kits

Adapter kit		Designation	Components	Mat. No.
Adapter kit I	IP55	SK T14-12-adapter kit_63-71	Adapter plate, terminal box frame seal and screws	275119050
	IP66	SK T14-12-adapter kit_63-71-C		275274324
Adapter kit II	IP55	SK T14-3-adapter kit_80-112	Adapter plate, terminal box frame seal and screws	275274321
	IP66	SK T14-3-adapter kit_80--C		275274325
Adapter kit III	IP55	SK T14-4-adapter kit_132	Adapter plate, terminal box frame seal and screws	275274320
	IP66	SK T14-132-adapter kit_132-C		275274326

### 2.1.2.2 Dimensions, SK 2xxE mounted on motor

Size		Housing dimensions SK 2xxE/motor					Weight of SK 2xxE without motor Approx. [kg]
VFD	Motor	Ø g	g 1	n	o	p	
Size 1	Size 71 <sup>1)</sup>	145	201	236	214	156	3.0
	Size 80	165	195		236		
	Size 90 S/L	183	200		251/276		
	Size 100	201	209		306		
Size 2	Size 80	165	202	266	236	176	4.1
	Size 90 S/L	183	207		251/276		
	Size 100	201	218		306		
	Size 112	228	228		326		
Size 3	Size 100	201	251	330	306	218	6.9
	Size 112	228	261		326		
	Size 132 S/M	266	262		373/411		
Size 4	Size 132	266	313	480	411	305	17.0
	Size 160	320	318		492		
	Size 180	358	335		614		

All dimensions in [mm]  
 1) incl. additional adapter and gasket (18 mm) [275119050]

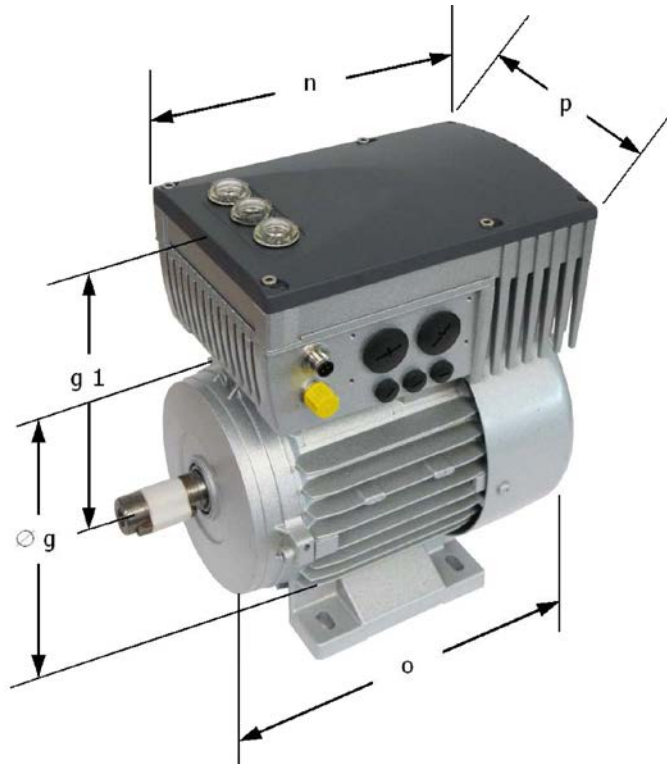

### 2.1.3 Wall mounting

As an alternative to motor mounting, the device can also be installed close to the motor using an optional wall mounting kit.

#### 2.1.3.1 Wall mounting kit without fan

##### Wall mounting kit SK TIE4-WMK-... (...1-K, ...2-K, ...3)

The wall-mounting kits are equally suitable for IP55 and IP66 applications and essentially consist of the following materials:

- SK TIE4-WMK-1-K: Plastic
- SK TIE4-WMK-2-K: Plastic
- SK TIE4-WMK-3: Stainless steel

VFD size	Device model	Housing dimensions			Mounting dimensions					Tot. weight approx. [kg]
		g2	n	p	d1	d2	e1	e2	Ø	
Size 1	SK TIE4-WMK-1-K Mat. No. 275 274 004	130.5	236	156	205	180	95	64	5.5	3.1
Size 2	SK TIE4-WMK-1-K Part No. 275 274 004	137.5	266	176						4.2
Size 3	SK TIE4-WMK-2-K Part No. 275 274 015	154.5	330	218	235.5	210.5	105	74	5.5	7.0
Size 4	SK TIE4-WMK-3 Part No. 275 274 003	168	470	305	295	255	150	100	8.5	19
		All dimensions in [mm]								

### Information

#### Derating

When using the wall-mounting kits SK TIE4-WMK-1-K and SK TIE4-WMK-2-K, the variable frequency drive no longer has optimum ventilation. Therefore, the maximum continuous power output can be considerably lower than is typical for wall mounting, especially with 3-phase variable frequency drives. Please refer to the technical data (please see chapter 7.2 "Electrical data" on page 237) for details.

A fan block is integrated in size 4 of the SK 2xxE as a standard so that no power derating can occur.

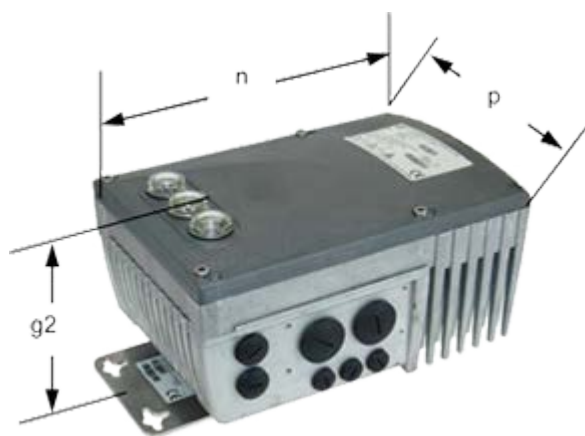

Figure 7: SK 2xxE with wall mounting kit

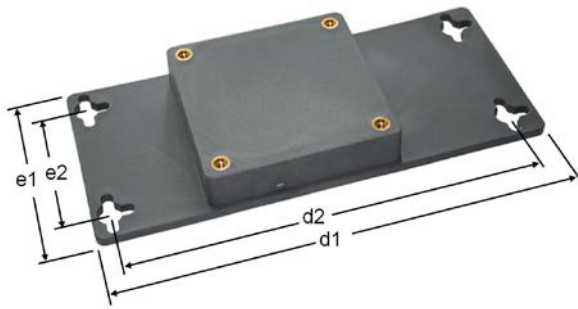

Figure 8: SK TIE4-WMK-1-K (or. -2-K)

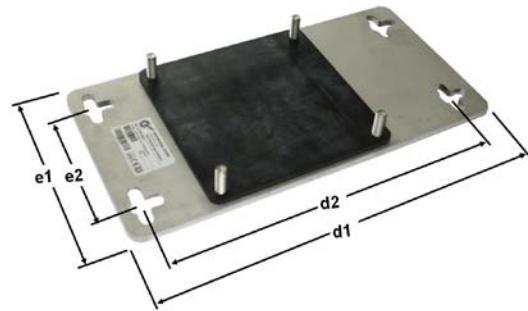

Figure 9: SK TIE4-WMK-3

### Wall mounting kit SK TIE4-WMK-... (...1-EX, ...2-EX)

These wall mounting kits are intended for use in explosion hazard environments (📖 Section 2.6 "Operation in potentially explosive environments"). They are made of stainless steel and are usable for IP55 and IP66.

#### **i** Information

#### De-rating

With the use of the wall mounting kit, the frequency inverter is no longer optimally ventilated. Therefore, the maximum continuous power output can be considerably lower than is typical for wall mounting, especially with 3-phase variable frequency drives. For details, please refer to the technical data (📖 Section 7.2 "Electrical data").

VFD size	Wall mounting kit	Housing dimensions			Mounting dimensions					Tot. weight approx. [kg]
		g2	n	p	d1	d2	e1	e2	Ø	
Size 1	SK TIE4-WMK-1-EX Mat. No. 275 175 053	130.5	236	156	205	180	95	64	5.5	3.5
Size 2	SK TIE4-WMK-1-EX Part No. 275 175 053	137.5	266	176						4.6
Size 3	SK TIE4-WMK-2-EX Part No. 275 175 054	154.5	330	218	235.5	210.5	105	74	5.5	7.5
		All dimensions in [mm]								



Figure 10: SK 2xxE with wall mounting kit

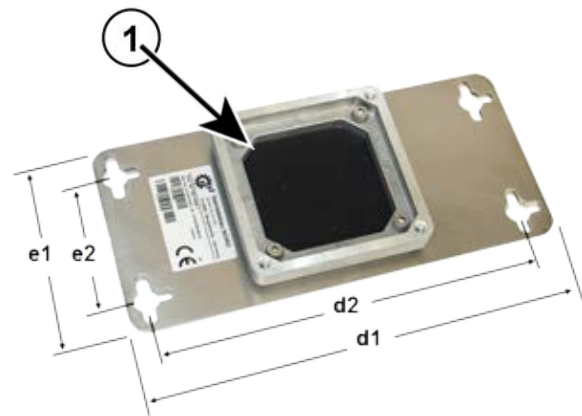

1 Adapter plate

Figure 11: SK TIE4-WMK... (...1-EX / 2-EX)

### 2.1.3.2 Wall mounting kit with fan

#### Wall mounting kit SK TIE4-WMK-L-...

The wall mounting kit SK TIE4-WMK-L-... enables the variable frequency drive to be installed close to the motor. With this kit, the variable frequency drive can comply with the IP55 or IP66 rating depending on the version.

- This kit is only available for inverter sizes 1 to 3.
- This kit cannot be combined with the device variants SK 22xE and SK 23xE (devices with AS interface).

When installing make sure that the fan is located below the cooling fins of the inverter. The fan connection cable must be inserted through the cable inlet in the variable frequency drive connection unit (see diagram below) and wired to +24 V DC (red cable) and GND (black cable) on the terminal block.

Power consumption of fan: **approx. 1.3 W**

## Information

### Derating

Use of the wall mounting kit SK TIE4-WMK-L-1 (or -2) allows the variable frequency drive to have continuous ventilation. Therefore the permissible continuous outputs of a 3-phase variable frequency drive correspond to those of a motor-mounted inverter. For single-phase variable frequency drives the same power data applies to wall mounting. Please refer to the technical data (please see chapter 7.2 "Electrical data" on page 237) for details.

## 2 Mounting and installation

VFD size	Device model	Housing dimensions			Mounting dimensions						Tot. weight approx. [kg]
		g2	n	p	d1	d2	d3	e1	e2	∅	
Size 1	SK TIE4-WMK-L-1 IP55 Part. No. 275274005	150.5	236	156	257	187	61	130	100	5.5	3.3
	SK TIE4-WMK-L-1-C IP66 Part. No. 275274016										
Size 2	SK TIE4-WMK-L-1 IP55 Part. No. 275274005	157.5	266	176	303	212	81	150	120	5.5	4.4
	SK TIE4-WMK-L-1-C IP66 Part. No. 275274016										
Size 3	SK TIE4-WMK-L-2 IP55 Part. No. 275274006	174.5	330	218	303	212	81	150	120	5.5	7.3

All dimensions in [mm]

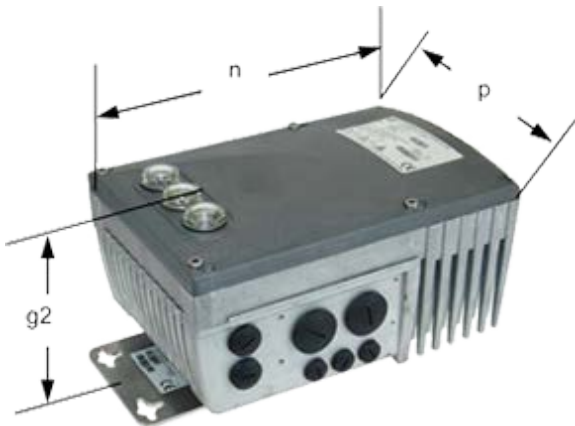
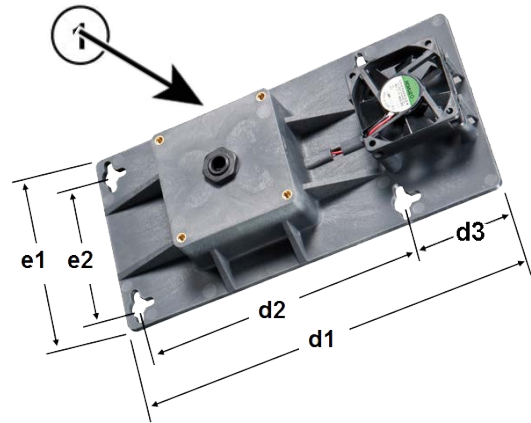

Figure 12: SK 2xxE with wall mounting kit



1 Installation of fan connecting cable

Figure 13: SK TIE4-WMK-L ...

### 2.1.3.3 Variable Frequency Drive mounting positions with wall mounting kit

Installation of the variable frequency drive close to the motor is permissible in the following mounting positions.

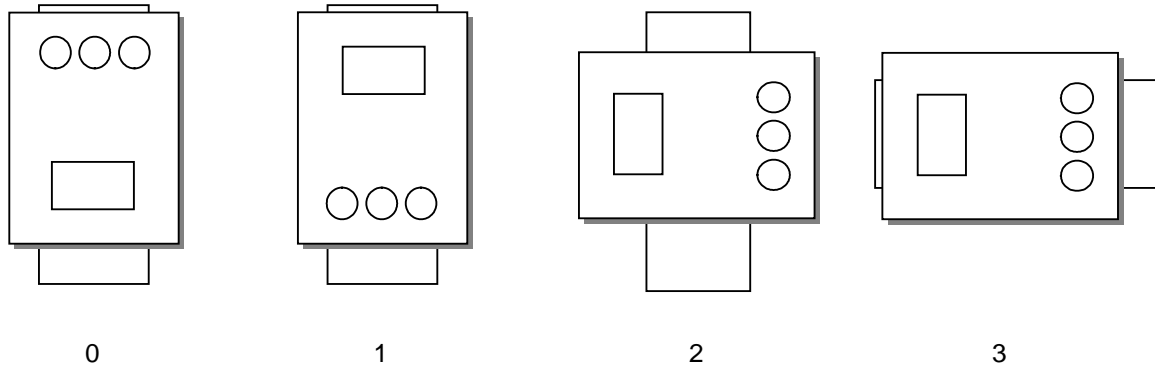

Figure 14: Variable Frequency Drive mounting positions with wall mounting kit

		0	1	2	3
<b>Mounting position</b>	<b>Variable Frequency Drive</b>	<b>vertical</b>	<b>vertical</b>	<b>horizontal</b>	<b>horizontal</b>
	<b>Position of cooling fins (/fan)</b>	<b>bottom</b>	<b>top</b>	<b>on side</b>	<b>on side</b>
	<b>Wall mounting kit</b>	<b>vertical</b>	<b>vertical</b>	<b>vertical</b>	<b>horizontal</b>
Model Wall mounting kit	SK TIE4-WMK-1-K SK TIE4-WMK-2-K	-	√	√	√
	SK TIE4-WMK-1-EX SK TIE4-WMK-2-EX	-	√	√	√
	SK TIE4-WMK-3	√	-	√	√
	SK TIE4-WMK-L-1 SK TIE4-WMK-L-2	-	√	-	√

√ = permissible / - = not permissible.



### 2.2 Installation of optional modules

Modules must not be inserted or removed unless the device is de-energized. The slots may only be used for the intended modules.

#### 2.2.1 Optional slots on the device

The mounting locations for optional modules are not directly on the variable frequency drive but on its connection unit.

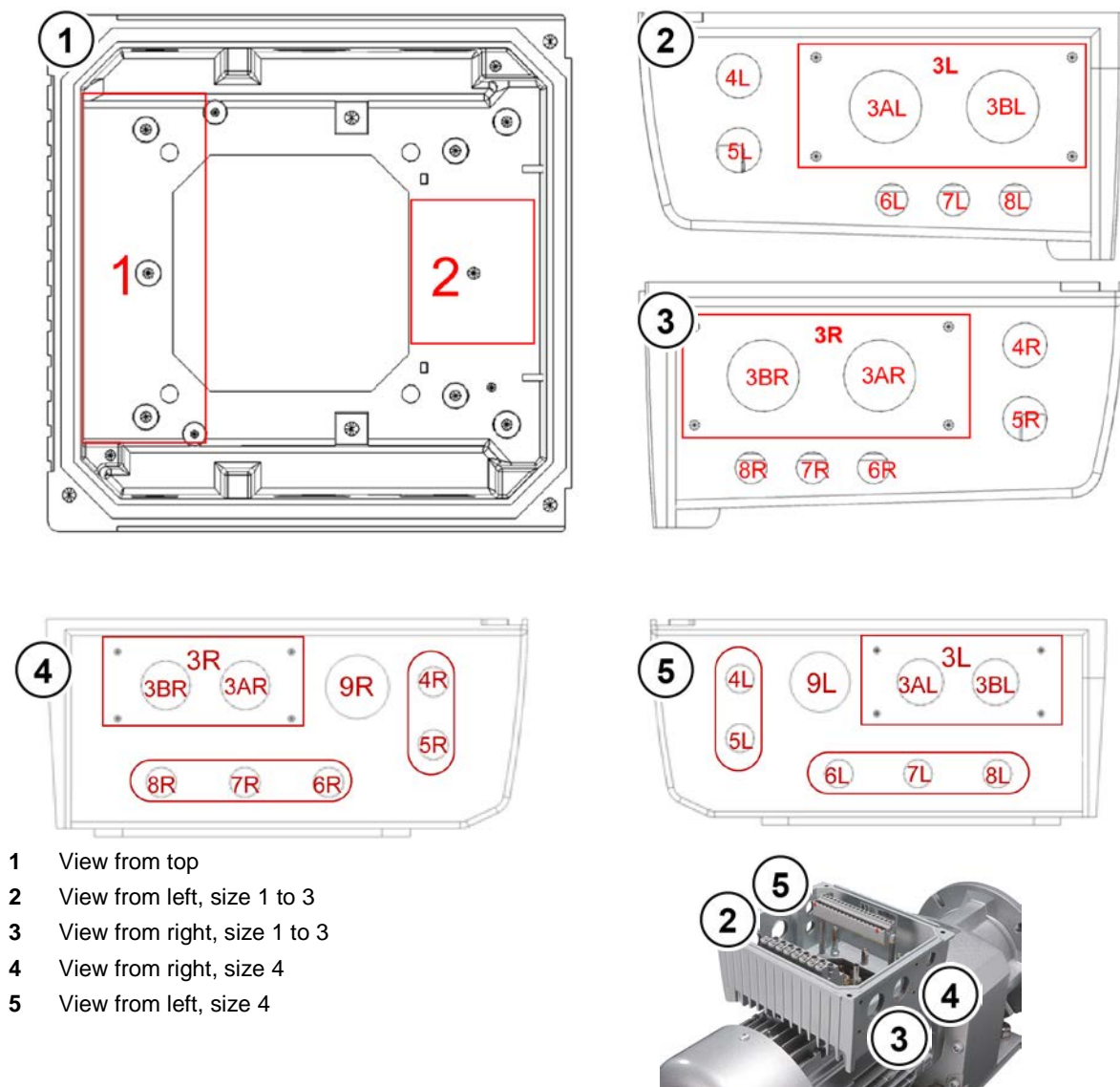

- 1 View from top
- 2 View from left, size 1 to 3
- 3 View from right, size 1 to 3
- 4 View from right, size 4
- 5 View from left, size 4

**Figure 15: Optional slots on the connection unit**

The diagrams above show the various mounting locations for the optional modules. Optional slot 1 is used for the installation of an internal bus module or an internal power supply unit (not SK 2x0E). An internal braking resistor can be mounted in optional slot 2. External bus modules, 24 VDC control power supply units (not SK 2x0E) or potentiometer modules can be installed in optional slot 3L or 3R. The same applies to external braking resistors. Optional slots 4 and 5 are used to install M12 sockets or connectors. Additional extensions from M12 to M16 are required in slots 6, 7 and 8 for sizes 1 to 3 so that M12 sockets and connectors can also be mounted here. Optional slots 6 - 8 are also designed as M16 for size 4 devices. Only one option can be installed in one optional slot. The preferred

mounting location for M12 sockets or connectors should be 4L or 4R. An additional M32 hole (optional slot 9) is provided for the power supply connection of size 4.

Optional slot	Position	Meaning	Size 1 - 3	Size 4	Comments
1	Internal	Mounting location for customer units SK CU4-...			
2	Internal	Mounting location for internal braking resistor SK BRI4-...			
3*	on side	Mounting location for <ul style="list-style-type: none"> <li>• external braking resistor SK BRE4-...</li> <li>• external technology modules SK TU4-...</li> <li>• control options</li> <li>• power connector</li> </ul>			
3 A/B*	on side	Cable gland	M25	M25	Not available if slot 3 is occupied or SK TU4-... is mounted.
4 *	on side	Cable gland	M16	M16	Not available if SK TU4-... is mounted.
5 *					
6 *	on side	Cable gland	M12	M16	Not available if slot 3 is occupied by SK BRE4 or SK TU4-... is mounted.
7 *					
8 *					
9*	on side	Cable gland	--	M32	Preferably used for power cable
* R and L (right and left side)					

### 2.2.2 Mounting of internal customer unit SK CU4-... (installation)



#### Information

#### Mounting location of customer unit

Mounting of the SK CU4... **customer unit** separately- from the device is not permitted. It must always be mounted inside the device in the intended position (optional slot 1). Only one customer unit can be installed per device.

Ready-made cables are provided with the customer unit.

Connections are made according to the following table.



Similar to illustration  
Accessories kit with internal customer unit

#### Allocation of the cable sets (accessories kit with the customer unit)

	Function	Terminal label	Cable color	
Field bus/OE	Voltage supply (24 V DC) (between device and customer unit)	44	24 V	brown
		40	GND/0 V	blue
	System bus	77	SYS H (+)	black
		78	SYS L (-)	gray
Power supply unit	Voltage supply (24 V DC) (between device and customer unit)	44	24 V	brown
		40	GND/0 V	blue
	Power supply (line power (AC)) (between supply network and customer unit)	L1	L1	brown
		L2	L2	black
Frequency output	B1	DOUT BUS (FOUT)	black	

The bus modules require a 24 V supply voltage to operate.

The customer units are installed inside connection unit SK TI4-...of the SK 2xxE, beneath the control terminal block.

Fastening is by means of the control terminal block of the variable frequency drive and two screw bolts (accessory kit enclosed with the customer unit).

Only one customer unit per device is possible!

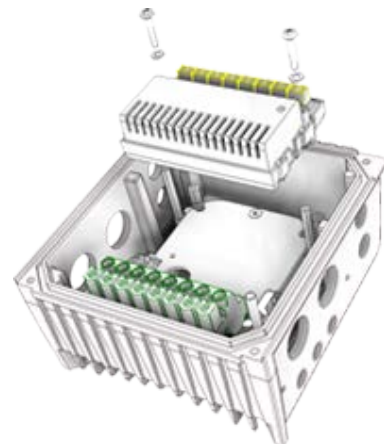

### 2.2.3 Installation of external technology units SK TU4-... (attachment)

Technology units SK TU4-...(-C) require a connection unit SK TI4-TU-...(-C). This is the only way to create a closed functional unit. This can be attached to the device or installed separately by means of the optional SK TIE4-WMK-TU wall mounting kit. Avoid cable lengths of more than 20 m between the technology unit and the device in order to ensure reliable operation.

#### **i** Information

#### Detailed installation information

Please refer to the documents for the connection unit concerned for a detailed description.

Connection unit	Document
SK TI4-TU-BUS	<a href="#">TI 275280000</a>
SK TI4-TU-BUS-C	<a href="#">TI 275280500</a>
SK TI4-TU-NET	<a href="#">TI 275280100</a>
SK TI4-TU-NET-C	<a href="#">TI 275280600</a>
SK TI4-TU-MSW	<a href="#">TI 275280200</a>
SK TI4-TU-MSW-C	<a href="#">TI 275280700</a>
SK TI4-TU-SAFE	<a href="#">TI 275280300</a>
SK TI4-TU-SAFE-C	<a href="#">TI 275280800</a>

### 2.3 Braking resistor (BW) - (from size 1)

During dynamic braking (frequency reduction) of a three-phase motor, electrical energy is fed back to the inverter if necessary. **From size 1** and above, an internal or external braking resistor can be used to avoid a shutdown of the device due to overvoltage. The integrated brake chopper (electronic switch) sheds the excess DC link voltage (operating point approx. 420 V/720 V<sub>DC</sub>, depending on line voltage) to the braking resistor. The braking resistor converts excess energy into heat.

#### CAUTION

##### Hot surfaces

The braking resistor and all other metal components can heat up to temperatures above 70°C.

- Risk of injury due to local burns on contact.
- Heat damage to adjacent objects

Allow sufficient cooling time before starting work on the product. Check the surface temperatures with suitable measuring equipment. Maintain an adequate distance to adjacent components.

#### Information

#### Parameterization of braking resistor data

To protect the braking resistor from overload, the electrical characteristics of the braking resistor must be parameterized in parameters **P555**, **P556** and **P557**. With use of an *internal braking resistor* (SK BRI4-...) this is done by setting the DIP switch **S1:8** ( Section 2.3.1)

#### 2.3.1 Internal braking resistor SK BRI4-...

The internal braking resistor can be used if only slight, short braking period are to be expected. The item includes a set of 2 braking resistors in the individual rating classes of size 4. These must be connected in parallel and thereby satisfy the electrical data from the description of the material. The mounting location for the 2nd braking resistor is opposite the mounting location of the 1st braking resistor.

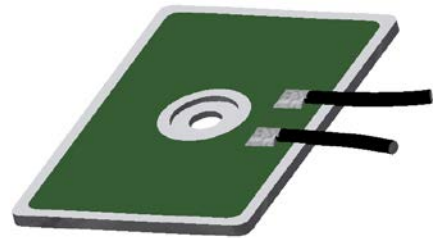

Similar to illustration

### Installation

Size 1 ... 3

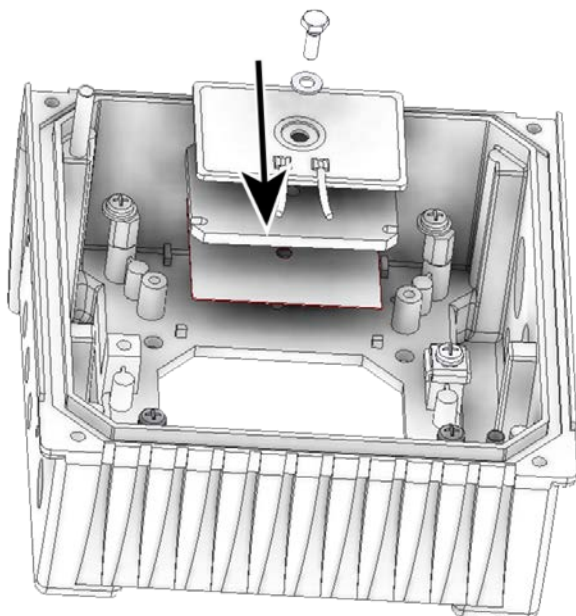

Size 4

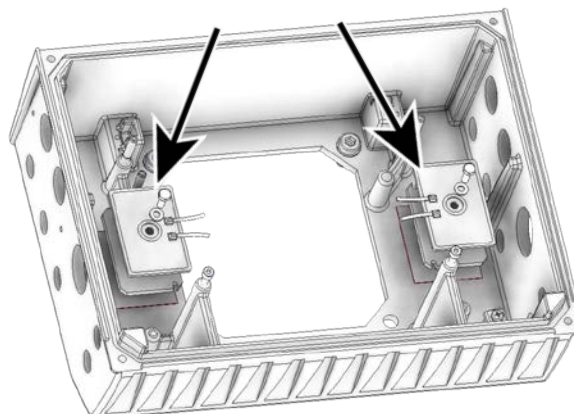

The capacity of the SK BRI4 is limited (see also the following note field) and can be calculated as follows.

$$P = P_n * \left(1 + \sqrt{(30/t_{brake})}\right)^2 \text{ but the following applies } P < P_{max}$$

(P=braking power (W), P<sub>n</sub>= continuous braking power of resistor (W), P<sub>max</sub>. peak braking power, t<sub>brake</sub> = duration of braking process (s))

The permissible continuous braking power P<sub>n</sub> must not be exceeded on average in the long-term.

### **i** Information

### Peak load limitation - DIP switch (S1)

Switch the DIP switch (S1), DIP-No. 8 (please see chapter 4.3.2.2 "DIP switches (S1)") to "on" when using internal braking resistors. This is important in order to activate a maximum output limit to protect the braking resistor.

#### Electrical data

Designation (IP54)	Mat. No.	Resistor	Max. continuous output/limit <sup>2)</sup> (P <sub>n</sub> )	Power consumption <sup>1)</sup> (P <sub>max</sub> )	Connecting cable or terminals
SK BRI4-1-100-100	275272005	100 Ω	100 W/25%	1.0 kW	Silicone flexible lead 2x AWG 20 approx. 60 mm
SK BRI4-1-200-100	275272008	200 Ω	100 W/25%	1.0 kW	
SK BRI4-1-400-100	275272012	400 Ω	100 W/25%	1.0 kW	
SK BRI4-2-100-200	275272105	100 Ω	200 W/25%	2.0 kW	Silicone flexible lead 2x AWG 18 approx. 60 mm
SK BRI4-2-200-200	275272108	200 Ω	200 W/25%	2.0 kW	
SK BRI4-3-047-300	275272201	47 Ω	300 W/25%	3.0 kW	Silicone flexible lead 2x AWG 16 approx. 170 mm
SK BRI4-3-100-300	275272205	100 Ω	300 W/25%	3.0 kW	
SK BRI4-3-023-600	275272800 <sup>3)</sup>	23 Ω (2 x 47 Ω)	600 W/25% (2 x 300 W)	6.0 kW (2 x 3 kW)	Silicone flexible lead 2x 2x AWG 16 approx. 170 mm
SK BRI4-3-050-600	275272801 <sup>3)</sup>	50 Ω (2 x 100 Ω)	600 W/25% (2 x 300 W)	6.0 kW (2 x 3 kW)	
<b>NOTE:</b> DIP switch (S1), DIP-No. 8 = on	1) Maximum once within 10 s <sup>2)</sup> 2) In order to prevent inadmissible heating of the connection unit, the continuous power is limited to 1/4 of the rated power of the braking resistor. This also has a limiting effect on energy consumption. 3) Set consisting of 2 resistors to be connected in parallel				

### 2.3.2 External braking resistor SK BRE4-... / SK BRW4-... / SK BREW4-...

The external braking resistor is provided for energy feedback, e.g. as occurs in pulsed drive units or lifting gear. It may be necessary here to plan for the exact braking resistor required (see adjacent figure).



Installation of an SK BRE4-... is not possible in combination with wall mounting kit **SK TIE4-WMK**..... In this case, braking resistors of type **SK BREW4-...** are available as an alternative and they can also be mounted on the variable frequency drive.

In addition **SK BRW4-...** type braking resistors are available for mounting on a wall near the device.

#### Electrical data

Designation <sup>1)</sup> (IP67)	Resistor	Max. continuous power (P <sub>n</sub> )	Power consumption <sup>2)</sup> (P <sub>max</sub> )
SK BRx4-1-100-100	100 Ω	100 W	2.2 kW
SK BRx4-1-200-100	200 Ω	100 W	2.2 kW
SK BRx4-1-400-100	400 Ω	100 W	2.2 kW
SK BRx4-2-100-200	100 Ω	200 W	4.4 kW
SK BRx4-2-200-200	200 Ω	200 W	4.4 kW
SK BRx4-3-050-450	50 Ω	450 W	3.0 kW
SK BRx4-3-100-450	100 Ω	450 W	3.0 kW
1) SK BRx4-: Variants: SK BRE4-, SK BRW4-, SK BREW4- 2) Maximum once within 120 s			

#### External braking resistors for motor-mounted variable frequency drives

The **SK BRE4-** series is intended for direct mounting on a motor-mounted variable frequency drive.

Please refer to the relevant product-specific documentation for detailed information about the braking resistors.

Name	Material number	Document
SK BRE4-1-100-100	275273005	<a href="#">TI 275273005</a>
SK BRE4-1-200-100	275273008	<a href="#">TI 275273008</a>
SK BRE4-1-400-100	275273012	<a href="#">TI 275273012</a>
SK BRE4-2-100-200	275273105	<a href="#">TI 275273105</a>
SK BRE4-2-200-200	275273108	<a href="#">TI 275273108</a>
SK BRE4-3-050-450	275273201	<a href="#">TI 275273201</a>
SK BRE4-3-100-450	275273205	<a href="#">TI 275273205</a>



### External braking resistors for wall-mounted variable frequency drives

The **SK BRW4-** series is intended for wall mounting in the vicinity of a wall-mounted variable frequency drive.

The **SK BREW4-** series is intended for direct mounting on a wall-mounted variable frequency drive.

The electrical data are identical to those for the **SK BRE4-** series. Please refer to the relevant product-specific document for detailed information.

Name	Material number	Document
SK BRW4-1-100-100	275273305	<a href="#">TI 275273305</a>
SK BRW4-1-200-100	275273308	<a href="#">TI 275273308</a>
SK BRW4-1-400-100	275273312	<a href="#">TI 275273312</a>
SK BRW4-2-100-200	275273405	<a href="#">TI 275273405</a>
SK BRW4-2-200-200	275273408	<a href="#">TI 275273408</a>
SK BRW4-2-400-200	275273412	<a href="#">TI 275273412</a>
SK BRW4-3-100-450	275273505	<a href="#">TI 275273505</a>
SK BREW4-1-100-100	275273605	<a href="#">TI 275273605</a>
SK BREW4-1-200-100	275273608	<a href="#">TI 275273608</a>
SK BREW4-1-400-100	275273612	<a href="#">TI 275273612</a>
SK BREW4-2-100-200	275273705	<a href="#">TI 275273705</a>
SK BREW4-2-200-200	275273708	<a href="#">TI 275273708</a>
SK BREW4-2-400-200	275273712	<a href="#">TI 275273712</a>

### Information

### Braking resistor

Other versions or installation variants for external braking resistors can be provided upon request.

### 2.3.3 Braking resistor assignments

NORD braking resistors are tailored directly to the individual devices. However, when external braking resistors are being used, it is usually possible to select between 2 or 3 alternatives.

Device SK 2xxE-...	Internal Braking resistor	External braking resistor <sup>1)</sup>		
		preferred	alternative	alternative
250-112-O	SK BRI4-1-100-100	SK BRx4-1-100-100	SK BRx4-2-100-200	
370-112-O	SK BRI4-1-100-100	SK BRx4-1-100-100	SK BRx4-2-100-200	
550-112-O	SK BRI4-1-100-100	SK BRx4-1-100-100	SK BRx4-2-100-200	
750-112-O	SK BRI4-1-100-100	SK BRx4-1-100-100	SK BRx4-2-100-200	
250-123-A	SK BRI4-1-100-100	SK BRx4-1-100-100	SK BRx4-2-100-200	
370-123-A	SK BRI4-1-100-100	SK BRx4-1-100-100	SK BRx4-2-100-200	
550-123-A	SK BRI4-1-100-100	SK BRx4-1-100-100	SK BRx4-2-100-200	
750-123-A	SK BRI4-1-100-100	SK BRx4-1-100-100	SK BRx4-2-100-200	
111-123-A	SK BRI4-1-100-100	SK BRx4-1-100-100	SK BRx4-2-100-200	
250-323-A	SK BRI4-1-200-100	SK BRx4-1-200-100	SK BRx4-2-200-200	SK BRx4-2-100-200
370-323-A	SK BRI4-1-200-100	SK BRx4-1-200-100	SK BRx4-2-200-200	SK BRx4-2-100-200
550-323-A	SK BRI4-1-200-100	SK BRx4-1-200-100	SK BRx4-2-200-200	SK BRx4-2-100-200
750-323-A	SK BRI4-1-200-100	SK BRx4-1-200-100	SK BRx4-2-200-200	SK BRx4-2-100-200
111-323-A	SK BRI4-1-200-100	SK BRx4-1-200-100	SK BRx4-2-200-200	SK BRx4-2-100-200
151-323-A	SK BRI4-1-200-100	SK BRx4-1-200-100	SK BRx4-2-200-200	SK BRx4-2-100-200
221-323-A	SK BRI4-1-200-100	SK BRx4-1-200-100	SK BRx4-2-200-200	SK BRx4-2-100-200
301-323-A	SK BRI4-2-100-200	SK BRx4-2-100-200		
401-323-A	SK BRI4-2-100-200	SK BRx4-2-100-200		
551-323-A	SK BRI4-3-047-300	SK BRx4-3-050-450		
751-323-A	SK BRI4-3-047-300	SK BRx4-3-050-450		
112-323-A	SK BRI4-3-023-600	SK BRx4-3-050-450		
550-340-A	SK BRI4-1-400-100	SK BRx4-1-400-100	SK BRx4-2-200-200	
750-340-A	SK BRI4-1-400-100	SK BRx4-1-400-100	SK BRx4-2-200-200	
111-340-A	SK BRI4-1-400-100	SK BRx4-1-400-100	SK BRx4-2-200-200	
151-340-A	SK BRI4-1-400-100	SK BRx4-1-400-100	SK BRx4-2-200-200	
221-340-A	SK BRI4-1-400-100	SK BRx4-1-400-100	SK BRx4-2-200-200	
301-340-A	SK BRI4-1-400-100	SK BRx4-1-400-100	SK BRx4-2-200-200	
401-340-A	SK BRI4-1-400-100	SK BRx4-1-400-100	SK BRx4-2-200-200	
551-340-A	SK BRI4-2-200-200	SK BRx4-2-200-200		
751-340-A	SK BRI4-2-200-200	SK BRx4-2-200-200		
112-340-A	SK BRI4-3-100-300	SK BRx4-3-100-450		
152-340-A	SK BRI4-3-100-300	SK BRx4-3-100-450		
182-340-A	SK BRI4-3-050-600	SK BRx4-3-100-450		
222-340-A	SK BRI4-3-050-600	SK BRx4-3-100-450		

1) SK BRx4-: Variants: SK BRE4-, SK BRW4-, SK BREW4-

Table 7: Assignment of braking resistors to variable frequency drive

### 2.4 Electrical connection

#### WARNING

##### Electric shock

Dangerous voltages can be present at the power input and the motor connection terminals even when the device is not in operation.

- Before starting work, check whether all relevant components (voltage source, connection cables, connection terminals of the device) are de-energized using suitable measuring equipment.
- Use insulated tools (e.g. screwdrivers).
- DEVICES MUST BE GROUNDED.

#### Information

##### Temperature sensor and PTC thermistor (TF)

As with other signal cables, PTC thermistors must be laid separately from motor cables. Otherwise the interference signals induced by the motor winding into the line will cause a disturbance in the device.

Ensure that the device and the motor are specified for the correct supply voltage.

In order to establish the electrical connections, remove the SK 2xxE from the SK TI4-... connection unit ( Section 2.1.2 "Motor installation steps").

One terminal block is provided for the power connections and one for the control connections.

The PE connections (device ground) are inside the cast housing of the connection unit on the bottom. One contact is available on the power terminal block for size 4.

The terminal block assignments differ according to the version of the device. The correct assignment can be found on the inscription on the respective terminal or the terminal overview plan printed inside the device.

	Connecting terminals for
(1)	Power cable Motor cable Braking resistor wires
(2)	Control wires Electromechanical brake PTC thermistor (TF) of motor
(3)	PE



### 2.4.1 Wiring guidelines

The devices were developed for use in an industrial environment. Electromagnetic interference in this environment can cause disturbances in the device. In general, correct installation ensures safe and problem-free operation. To meet the limiting values of the EMC directives, take account of the following instructions.

- 1 Make sure that all devices connected to a common grounding point or a grounding bar are well grounded using short ground conductors with a large cross-section. It is especially important that each control unit which is connected to the electronic drive equipment (e.g. an automatic device) is connected to the same grounding point as the device itself through a short conductor with a large cross-section. Flat conductors (e.g. metal brackets) are preferable as they have a lower impedance at high frequencies.
- 2 Connect the PE conductor of the device-controlled motor as directly as possible to the ground terminal of the associated device. The presence of a central grounding bar and the grouping together of all protective conductors on this bar normally ensures proper operation.
- 3 Use shielded cables for control circuits where possible. Connect the shielding at the cable end carefully and make sure the wires do not run over long stretches without shielding.  
The shields of analog setpoint cables should only be grounded on one side on the device.
- 4 Install control cables as far as possible from power cables using separate cable ducts, etc. Create an angle of 90° in cable crossings where possible.
- 5 Make sure the contactors in the cabinets are interference-protected by using either RC circuitry in case of AC contactors or freewheeling diodes for DC contactors, **whereby the interference suppression devices are attached to the contactor coils**. Varistors for overvoltage limitation are also effective.
- 6 Use shielded or armored cables for load connections (motor cable, if necessary). The shielding or armoring must be grounded at both ends. Grounding should be done directly on the PE of the device if possible.

In addition, EMC-compliant wiring must be ensured.

**Observe the safety regulations under all circumstances when installing the devices!**

#### NOTICE

##### Damage due to high voltage

The device may be damaged by electrical loads which do not correspond to its specification.

- Do not perform any high-voltage tests on the device itself.
- Disconnect the cable to be tested from the device before performing a high-voltage insulation test.

##### Information

##### Daisy-chaining of the line voltage

Adhere to the permissible current load for connection terminals, plugs and supply cables when Daisy-chaining the line voltage. Noncompliance will result in thermal damage to live modules and their immediate vicinity.

If the device is installed according to the recommendations in this manual, it meets all EMC directive requirements as per the EMC product standard EN 61800-3.

### 2.4.2 Electrical connection of power unit

#### NOTICE

##### EMC interference to the environment

This device produces high-frequency interference which may make additional suppression measures necessary in domestic environments (📖 Section 8.3 "Electromagnetic compatibility (EMC)").

- Use of shielded motor cables is essential in order to comply with the specified radio interference suppression level.

Please note the following when connecting the device:

- 1 Make sure that the AC power supply provides the correct voltage and is suitable for the current required (📖 Section 7 "Technical Data").
- 2 Make sure that suitable branch circuit protection with the specified rated current range are installed between the voltage source and the device.
- 3 Power cable connection: to terminals **L1-L2/N-L3** and **PE** (depending on device)
- 4 Motor connection: to terminals **U-V-W**

Use a 4-core motor cable if the device is being wall-mounted. In addition to **U-V-W**, connect **PE** as well. In this case, mount the cable shield, if present, on a large area of the metal screw connection of the cable inlet.

The use of ring cable lugs is recommended for connecting to PE.



#### Information

#### Connection cables

Use only copper cables with temperature class 80°C or equivalent for the connection. Higher temperature classes are permissible.

The maximum connection cross-section can be reduced when using **ferrules**.

Device	Cable Ø [mm²]		AWG	Tightening torque	
	rigid	flexible		[Nm]	[lb-in]
1 ... 3	0.5 ... 6	0.5 ... 6	20-10	1.2 ... 1.5	10.62 ... 13.27
4	0.5 ... 16	0.5 ... 16	20-6	1.2 ... 1.5	10.62 ... 13.27
<b>Electromechanical brake</b>					
1 ... 3	0.2 ... 2.5	0.2 ... 2.5	24-14	0.5 ... 0.6	4.42 ... 5.31
4	0.2 ... 4	0.2 ... 2.5	24-12	0.5 ... 0.6	4.42 ... 5.31

Table 8: Connection data

### 2.4.2.1 Power supply connection (L1, L2(N), L3, PE)

No special safety measures are required at the line input side of the device. It is advisable to use standard power fuses (see Technical Data) and a main switch or contactor.

Device data			Permissible power supply data			
Model	Voltage	Power	1 ~ 115 V	1 ~ 230 V	3 ~ 230 V	3 ~ 400 V
SK...112-O	115 VAC	0.25 ... 0.75 kW	X			
SK...123-A	230 VAC	0.25 ... 1.1 kW		X		
SK...323-A	230 VAC	≥ 0.25 kW			X	
SK...340-A	400 VAC	≥ 0.37 kW				X
Connections			L/N = L1/L2	L/N = L1/L2	L1/L2/L3	L1/L2/L3

Disconnection from or connection to the AC power supply must always take place at all poles and be simultaneous (L1/L2/L3 or L1/N).

In the factory default setting, the device is configured for operation in TN or TT systems (grounded neutral). The line filter here has its normal effect and the resulting leakage current. Use a supply system grounded in the neutral point, and a PEN conductor in single-phase devices!

**Adaptation to IT grids – (from size 1)**

#### **WARNING**

##### **Unexpected movement in case of power system fault**

In case of a power system fault (ground fault) a switched-off variable frequency drive may switch on automatically. Depending on the parameterization, this may cause the drive unit to start automatically and therefore cause a risk of injury.

- Secure the system against unexpected movement (block, decouple mechanical drive, provide protection against falling, etc.)

#### **NOTICE**

##### **Operation in IT networks (ungrounded supplies)**

If a power system fault (ground fault) occurs in an IT network (ungrounded), the DC link of a connected variable frequency drive may become charged even if it is switched off. This leads to the destruction of the DC-link capacitors due to overcharging.

- Connect a braking resistor to dissipate excess energy.
- Ensure that the variable frequency drive controller is ready for operation as necessary:
  - If a device with an integrated power supply unit (**SK 2x0E**) is used, the internal control unit and therefore all monitoring functions switch on automatically.
  - If a device without an integrated power supply unit (**SK 2x5E**) is used, the 24 V supply of the device must be switched on before the line voltage is switched on. The 24 V supply to the device must only be switched off after the device has been disconnected from the line voltage.

For operation in an IT system (ungrounded), make simple adaptations by relocating the jumpers (CY=OFF). However, this may result in impairment of radio interference suppression.

Take account of the insulation resistance of the device when operating on an insulation monitor (📖 Section 7 "Technical Data")

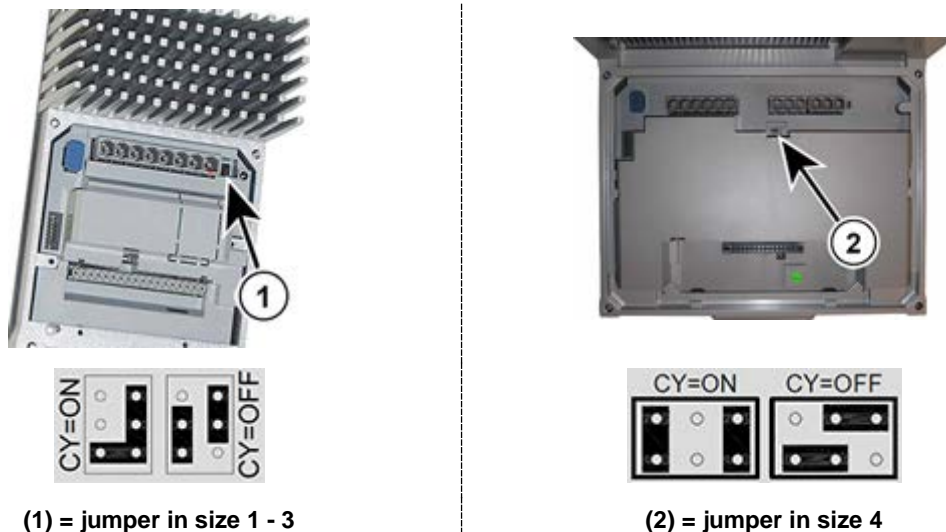

Figure 16: Jumpers for system adaptation

### Adaptation to HRG systems – (from size 1)

The device may also be operated in supply systems with a high-resistance grounded neutral point (**H**igh-**R**esistance **G**rounding) (typical for the USA). Take account of the same conditions and modifications here as those in an IT- system (see above).

### Use on different supply networks or network types

The device may only be connected to supply networks which are explicitly stated in this section (📖 Section 2.4.2.1 "Power supply connection (L1, L2(/N), L3, PE)"). Operation on **different network types** may be possible, but must be **checked and explicitly approved by the manufacturer in advance**.

### 2.4.2.2 Motor cable

The motor cable may have a total **length of 25 m** if it is a standard cable type (take EMC into consideration). If a shielded motor cable is used or if the cable is laid in a well-grounded metal duct, the total length should not exceed **5 m** (cable shield connected to PE bilaterally).

#### NOTICE

##### Output switching

Switching a motor cable under load causes an impermissibly high load on the device. Components in the power section may be damaged and destroyed either immediately or in the long term.

- Only switch the motor cable when the variable frequency drive no longer outputs power. I.e. the device must be in the "ready to switch on" or "switch-on block" state.



#### Information

##### Synchronous motors or multiple-motor operation

If synchronous machines or several motors are connected in parallel to a device, the variable frequency drive must be switched over to linear voltage/frequency characteristic curves, (→ P211 = 0 and P212 = 0).

For multiple-motor operation the total motor cable length is the sum of the individual motor cable lengths.

### 2.4.2.3 Braking resistor (+B, -B) – (from size 1)

The +B/-B terminals are used to connect a suitable braking resistor. Select the shortest possible, shielded link for the connection.



#### CAUTION

##### Hot surfaces

The braking resistor and all other metal components can heat up to temperatures above 70°C.

- Risk of injury due to local burns on contact.
- Heat damage to adjacent objects

Allow sufficient cooling time before starting work on the product. Check the surface temperatures with suitable measuring equipment. Maintain an adequate distance to adjacent components.



### 2.4.2.4 Electromechanical brake

Only valid for SK 2x5E size 1 - 3 and SK 2x0E size 4:

The device generates an output voltage at terminals 79/80 (MB+/MB-) for actuating an electromagnetic brake. This is dependent on the supply voltage present on the device. The allocation is as follows:

Line voltage/AC voltage	Brake coil voltage (DC)
115 V ~ / 230 V ~	105 V =
400 V ~	180 V =
460 V ~ / 480 V ~	205 V =
500 V ~	225 V =

The connecting terminals in the SK 2x5E are on the control terminal block, and in the SK 2x0E, size 4 they are somewhat separate from it.

Take the assignment of the correct brake and brake coil voltage into consideration in the design with regard to the device's line voltage.



### Information

#### Parameter P107/P114

Adjust parameters **P107** and **P114** ("Brake reaction time" and "Brake delay off") when connecting an electromechanical brake to the terminals of the device. Set value  $\neq 0$  in parameter **P107** to avoid damages in the brake control.

### 2.4.3 Electrical connection of the control unit

**Connection data:**

Terminal block		Size 1-4	Size 4
		typically	Terminals 79/80
Cable Ø *	[mm²]	0.2 ... 2.5	0.2 ... 4
AWG standard		24-14	24-12
Tightening torque	[Nm]	0.5 ... 0.6	0.5 ... 0.6
	[lb-in]	4.42 ... 5.31	4.42 ... 5.31
Slotted screwdriver	[mm]	3.5	3.5

\* flexible cable with ferrules (with or **without** plastic collar) or rigid cable

**SK 2x0E**

The device generates its own 24 V DC control voltage and provides this to terminal 43 (for connecting external sensor systems, for example).

However, size 4 devices can also be supplied by an external control voltage source (connection to terminal 44). The switchover between the internal and external power supply unit takes place automatically.

**SK 2x5E**

The device must be provided with an external 24 V DC control voltage. Alternatively, an optional 24 V DC power supply unit model SK CU4-... or SK TU4-... can be used.

The control voltage for devices that use the AS interface (SK 225E and SK 235E) must be supplied via the yellow AS interface line. However, in this case the variable frequency drive must not have an additional supply via terminal 44 in order to prevent damage to the power supply unit or the AS interface bus.

**i Information**

**Control voltage overload**

A control unit overload caused by impermissibly high currents may destroy the unit. Impermissibly high currents occur if the total current actually obtained exceeds the permissible total current, or if the 24 V DC control voltage for other devices is passed through the variable frequency drive. Use double ferrules, for example, to avoid conduction through the variable frequency drive.

The control unit can also be overloaded and destroyed if the 24 V DC supply terminals of devices with an integrated power supply unit (SK 2x0E) are connected to a different voltage source. For this reason, make sure that any wires for the 24 V DC power supply are not connected to the device but are insulated accordingly, particularly when installing connectors for the control connection (example of connector for system bus connection SK TIE4-M12-SYSS).

**i Information**

**Total currents**

24 V DC can be taken from several terminals as necessary. This also includes e.g. digital outputs or an operating module connected via RJ45.

The sum total of currents obtained must not exceed the following limits:

Device model	Size 1 to 3	Size 4
SK 2x0E	200 mA	500 mA
SK 2x5E	200 mA	-
Devices with AS interface, when using the AS interface	60 mA	60 mA

### **i** Information

#### Reaction time of digital inputs

The reaction time of a digital signal is approx. 4-5 ms and consists of the following:

Scan time	1 ms
Signal stability check	3 ms
Internal processing	< 1 ms

For digital inputs DIN2 and DIN3 there is a parallel channel which relays the signal pulses between 250 Hz and 205 kHz directly to the processor, and therefore makes it possible for a rotary encoder to be evaluated.

### **i** Information

#### Cable routing

All control cables (including PTC thermistors) must be routed separately from power and motor cables to prevent interference in the device.

If the cables are routed in parallel, keep a minimum distance of 20 cm from cables which carry a voltage of > 60 V. The minimum distance may be reduced by shielding live cables or by using grounded metal separator within the cable ducts.

Alternatively: Use of a hybrid cable with shielded control lines.

## Control terminal details

### Labeling, function

SH:	Function: Safe stop	DOUT:	Digital output
ASI+/-:	Integrated AS interface	24 V SH:	"Safe stop" input
24 V:	24 V DC control voltage	0 V SH:	"Safe stop" reference potential
10 V REF:	10 V DC reference voltage for AIN	AIN +/-:	Analog input
AGND:	Reference potential for analog signals	SYS H/L:	System bus
GND:	Reference potential for digital signals	MB+/-:	Control of electromechanical brake
DIN:	Digital input	TF+/-:	PTC thermistor connection of motor

### Connections depending on the variable frequency drive type

Detailed information regarding **functional safety** (safe stop) can be found in supplementary manual [BU0230](http://www.nord.com). - [www.nord.com](http://www.nord.com) -

### Sizes 1 ... 3

SK 200E	SK 210E SH	SK 220E ASI	SK 230E SH+ASI	Device model			SK 205E	SK 215E SH	SK 225E ASI	SK 235E SH+ASI
				Labeling						
				Pin						
24 V (output)				43	1	44	24 V (input)*			
AIN1+		ASI+		14/84	2	44/84	24 V (input)*		ASI+	
AIN2+				16	3	40	GND			
AGND		ASI-		12/85	4	40/85	GND		ASI-	
DIN1				21	5	21	DIN1			
DIN2				22	6	22	DIN2			
DIN3				23	7	23	DIN3			
DIN4	24 V SH	DIN4	24 V SH	24/89	8	24/89	DIN4	24 V SH	DIN4	24 V SH
GND	0 V SH	GND	0 V SH	40/88	9	40/88	GND	0 V SH	GND	0 V SH
DOUT1				1	10	1	DOUT1			
GND				40	11	40	GND			
SYS H				77	12	77	SYS H			
SYS L				78	13	78	SYS L			
10 V REF				11	14	-	---			
DOUT2				3	15	79	MB+			
GND				40	16	80	MB-			
TF+				38	17	38	TF+			
TF-				39	18	39	TF-			

\* when using the AS interface, terminal 44 provides an output voltage (26.5 V DC ... 31.6 V DC, max. 60 mA). In this case, no voltage sources may be connected to this terminal!

### Size 4

Device model		SK 200E	SK 210E (SH)	SK 220E (ASI)	SK 230E (SH+ASI)
Pin	Labeling				
1	43	24 V (output)			
2	43	24 V (output)			
3	40	GND			
4	40	GND			
5	-/84	/		ASI+	
6	-/85	/		ASI-	
7	11	10 V REF			
8	14	AIN1+			
9	16	AIN2+			
10	12	AGND			
11	44	24 V (input)			
12	44	24 V (input)			
13	40	GND			
14	40	GND			
15	21	DIN1			
16	22	DIN2			
17	23	DIN3			
18	24/89	DIN4	24 V SH	DIN4	24 V SH
19	40/88	GND	0 V SH	GND	0 V SH
20	40	GND			
21	1	DOUT1			
22	40	GND			
23	3	DOUT2			
24	40	GND			
25	77	SYS H			
26	78	SYS L			
27	38	TF+			
28	39	TF-			
Separate terminal block (2-pole):					
1	79	MB+			
2	80	MB-			

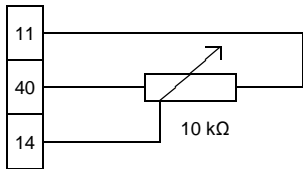
Meaning, Functions		Description/Technical data		
Terminal			Parameter	
No.	Designation	Meaning	No.	Function of factory setting
<b>Digital outputs</b>		Signaling of operating status of the device		
		24 V DC With inductive loads: Provide protection using freewheeling diode!	Maximum load 20 mA	
1	DOUT1	Digital output 1	P434 [-01]	Fault
3	DOUT2	Digital output 2	P434 [-02]	Fault
<b>Note:</b> Size 4: Max. load 50 mA SK 2x5E: Voltage level depending on input voltage level (18 – 30 V DC)				
<b>Analog inputs</b>		Actuation of device by external controller, potentiometer or similar device		
		Resolution 12 bit U= 0...10 V, R=30 kΩ I= 0/4 ... 20 mA Burden resistance (250 Ω) via DIP switch AIN1/2  Maximum permissible voltage at analog input: 30 V DC	The analog signals are adjusted via P402 and P403. + 10 V reference voltage: 5 mA not short-circuit-proof	
				
11	10V REF	+ 10 V reference voltage	-	-
14	AIN1+	Analog input 1	P400 [-01]	Setpoint frequency
16	AIN2+	Analog input 2	P400 [-02]	No function
40	GND	Reference potential GND	-	-
<b>CAUTION:</b> SK 200E and SK 210E: Use terminal 12 instead of terminal 40 (AGND/0 V)				
<b>Digital inputs</b>		Actuation of device using an external controller, switch, or similar device. HTL encoder connection possible with DIN2 and DIN3.		
		as per EN 61131-2, type 1 Low: 0-5 V (~ 9.5 kΩ) High: 15-30 V (~ 2.5 - 3.5 kΩ) Scan time: 1 ms Reaction time: 4 - 5 ms	Input capacitance 10 nF (DIN1, DIN 4) 1.2 nF (DIN 2, DIN 3) Cut-off frequency (only DIN 2 and DIN 3) Min.: 250 Hz, max.: 205 kHz	
21	DIN1	Digital input 1	P420 [-01]	ON right
22	DIN2	Digital input 2	P420 [-02]	ON left
23	DIN3	Digital input 3	P420 [-03]	Fixed frequency 1 (→ P465[-01])
24	DIN4	Digital input 4	P420 [-04]	Fixed frequency 2 (→ P465[-02])
<b>PTC thermistor input</b>		Monitoring of motor temperature using PTC		
		Use a shielded cable if the device is installed near the motor.	The input is always active. In order to make the device operational, a temperature sensor must be connected or both contacts must be jumpered.	
38	TF+	PTC thermistor input	-	-
39	TF-	PTC thermistor input	-	-

<b>Control voltage source</b>		Control voltage from the inverter, e.g. as power supply for accessories.		
		24 V DC $\pm$ 25%, short-circuit-proof	Maximum load 200 mA <sup>1)</sup>	
<b>43</b>	VO/24 V	Voltage output	-	-
<b>40</b>	GND/0 V	Reference potential GND	-	-

1) See "Total Currents" information (☞ Section 2.4.3 "Electrical connection of the control unit")

<b>Note:</b> Size 4: Max. load 500 mA				
---------------------------------------	--	--	--	--



<b>Control voltage connection</b>		Supply voltage for the device		
		24 V DC $\pm$ 25% (sizes 1 – 3) 24 V DC + 25% (size 4) 200 mA ... 800 mA, depending on load of inputs and outputs and use of options	Size 4: Automatic changeover between terminal 44 and internal power supply unit if connected control voltage is insufficient. With use of AS interface: <b>Do not connect a voltage source!</b> <b>Output voltage: 26.5 V – 31.6 V, <math>\leq</math> 60 mA</b>	
<b>44</b>	24 V	Voltage input	-	-
<b>40</b>	GND / 0V	Reference potential GND	-	-

<b>System bus</b>		NORD-specific bus system for communicating with other devices (e.g. smart optional modules or variable frequency drives)		
		Up to four variable frequency drives (SK 2xxE, SK 1x0E) can be operated on a single system bus.	→ Address = 32/34/36/38	
<b>77</b>	SYS H	System bus+	P509/510	Control terminals/Auto
<b>78</b>	SYS L	System bus-	P514/515	250 kBaud/address 32 <sub>dec</sub>

<b>System bus terminating resistor</b>		Termination at the physical ends of the bus system		
		<b>The correct setting of the termination resistors must be checked before commissioning. (1x at the beginning and 1x at the end of a system bus connection)</b>		
<b>S2</b>			Factory setting "ON"  (For different factory setting, see explanation above)	

<b>Brake actuation</b>		Connection and actuation of an electromechanical brake. The device generates an output voltage for this purpose. This depends on the line voltage. Take the assignment of the correct brake coil voltage into account in the selection.		
		<i>Connected loads:</i> (☞ Section 2.4.2.4 "Electromechanical brake") Current: $\leq$ 500 mA	Permissible switching cycle time: to 150 Nm: $\leq$ 1/s to 250 Nm: $\leq$ 0.5/s	
<b>79</b>	MB+	Brake control	P107/114	0/0
<b>80</b>	MB-	Brake control		

<b>NOTES:</b>				
SK 2x0E, size 4: $\leq$ 600 mA				
This function is identical to P434=1				

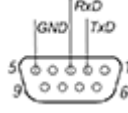
<b>AS interface</b>		Control of device via the simple field bus level: Actuator/sensor interface			
		26.5 – 31.6 V SK 220E and SK 230E: ≤ 25 mA SK 225E and SK 235E: ≤ 290 mA, of which a maximum of 60 mA required to supply external actuators	Only usable for yellow AS interface line, feed via black cable not possible. Configuration via DIP switches S1:4 and 5		
<b>84</b>	ASI+	ASI+	P480 ...	-	
<b>85</b>	ASI-	ASI-	P483	-	
<b>Functional Safety "Safe Stop"</b>		Fail-safe input			
		Details: BU0230, Technical Data	The input is always active. Supply this input with the required voltage in order to make the device ready for operation.		
<b>89</b>	VI/24V SS	24 V input	-	-	
<b>88</b>	VI/0V SS	Reference potential	-	-	
<b>Communication interface</b>		Device connected to different communication tools			
		24 VDC ± 20%	RS 485 (to connect a parameterization unit) 9600 ... 38400 Baud Terminating resistor (1 kΩ) fixed RS 232 (to connect a PC (NORD CON)) 9600 ... 38400 Baud		
<b>1</b>	RS485 A+	Data cable RS485	P502...	 <p>1 - 2 - 3 - 4 - 5 - 6</p>	
<b>2</b>	RS485 B-	Data cable RS485	P513 [-02]		
<b>3</b>	GND	Bus signal reference potential			
<b>4</b>	RS232 TXD	Data cable RS232			
<b>5</b>	RS232 RXD	Data cable RS232			
<b>6</b>	+24 V	Voltage output			
<b>Connection cables (accessories/optional)</b>		Connection of the device to an MS Windows® PC with NORDCON software			
		Length: approx. 3.0 m + approx. 0.5 m Part number: 275274604 Suitable for connection to a USB port in a PC or alternatively, to a SUB D9 connection. Details: <a href="#">TI 275274604</a>			



### 2.4.4 Power supply unit SK xU4-24V-... - connection example

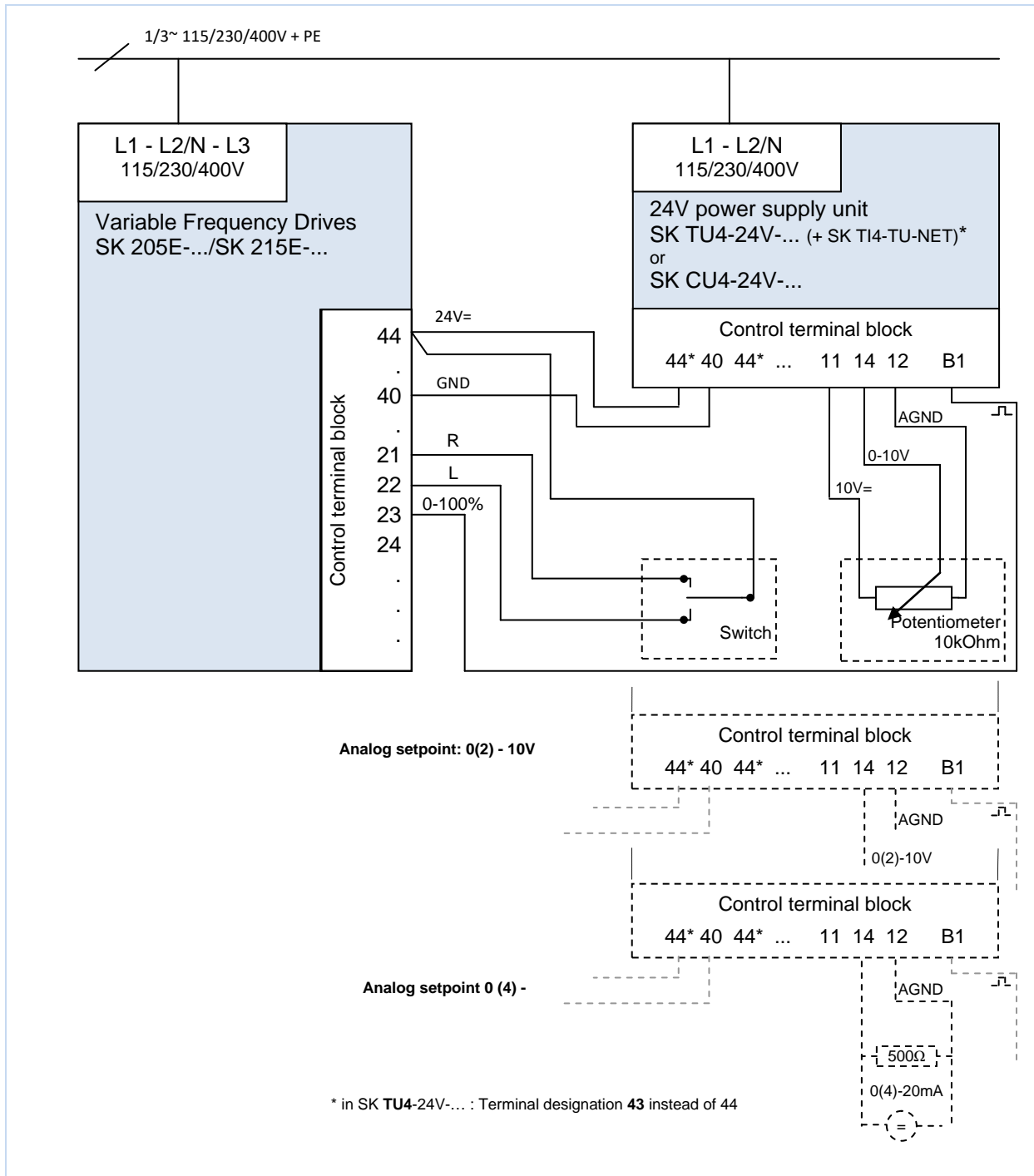

Figure 17: Connection example, power supply unit SK xU4-24V-...

Setting (S1): DIP3 = off, DIP4 = on, DIP5 = off (chapter 4.3.2.2)  
(DIP switches)

(can only be used for 0–10 V or 0–20 mA signals!)

or

recommended parameter setting,  
S1: DIP1-8 = off

P400 [07] = 1	P420 [02] = 2
P420 [01] = 1	P420 [03] = 26 (with 0-10 V/0-20 mA signals)
	27 (with 2-10 V/4-20 mA signals)

With device variants **SK 2x0E**, a power supply unit is integrated and so no external 24 V DC voltage supply is required. For *sizes 1-3* connection of an external power source (e.g. power supply unit SK xU4-24V-...) is not provided. No connection terminals are provided for this purpose. *Size 4* has appropriate terminals and allows the connection of an external voltage source (📖 section 0 "Control terminal details").

The SK 2x5E does not have its own analog input. In order to be able to evaluate an analog signal with this device variant (e.g. from a potentiometer), the analog signal can be converted into a pulse signal using the power supply unit and made usable by an appropriate digital function of the device.

In order to process current setpoints (0(4) - 20 mA) the accessories kit includes a 500 Ω resistor which must be connected between terminals 12 and 14. The relevant input on the variable frequency drive is adjusted via parameter P420.

Setpoint	Parameter [array]	Setting
0 ... 20 mA	P420 [-02] or [-03]	{26}
4 ... 20 mA	P420 [-02] or [-03]	{27}

### 2.5 Color and contact assignments for the incremental encoder (HTL)

Function	Wire colors, for incremental encoder <sup>1)</sup>	Assignment for SK 2xxE	
24V supply	brown/green	43 (/44)	24V (VO)
0V supply	white/green	40	0V (GND)
Track A	brown	22	DIN2
Track A inverse (A /)	green	--	
Track B	gray	23	DIN3
Track B inverse (B /)	pink	--	
Track 0	red	21	DIN1
Track 0 inverse	black	--	
Cable shield	Large-area connection to variable frequency drive housing.		
1) Wire colors depend on the type of encoder and may differ. Please <b>note</b> the encoder <b>data sheet</b> !			

Note the current consumption of the encoder (normally up to 150 mA) and the permissible load on the voltage source.

Only digital inputs DIN 2 and DIN 3 are in a position to process the signals of an HTL encoder. To use an encoder, activate parameters (P300) and/or (P600) according to requirements (speed feedback/servo mode or positioning).



#### Information

#### DIN 2 and DIN 3 double allocation

Digital inputs DIN2 and DIN3 are used for 2 different functions:

1. for digital functions that can be parameterized (e.g. "enable left"),
2. for evaluation of an incremental encoder.

Both functions are coupled by an OR link.

Evaluation of an incremental encoder is always activated. This means that when an incremental encoder is connected, make sure that the digital functions are switched off (parameter (P420 [-02] and [-03]) or with DIP switch (chapter 4.3.2.2)).



#### Information

#### Rotation direction

The "counting direction" of the incremental encoder must correspond to the direction of rotation of the motor. If the two directions are not identical, the connections of the encoder tracks (track A and track B) must be switched. Alternatively, the resolution (line number) of the encoder can be set with a negative prefix in the **P301** parameter.



#### Information

#### Encoder signal faults

Wires that are not required (e.g. track A inverse/B inverse) must be insulated.

Otherwise, if these wires come into contact with each other or the cable shield, short circuits can occur that can cause encoder signal problems or destruction of the encoder.

If the rotary encoder has a zero track, connect this to digital input 1 of the device. The zero track is read out by the variable frequency drive if parameter P420 [-01] has been set to function 43.

## 2.6 Operation in potentially explosive environments

### WARNING

#### Explosion hazard due to electricity



Electric sparks may ignite an explosive atmosphere.

- Do not open the device in an explosive atmosphere and do not remove any covers (e.g. diagnostic openings).
- All work on the device must only be carried out with the system **de-energized**.
- Wait for the required time ( $\geq 30$  min) after switching off.
- Before starting work, check that all relevant components (voltage source, connection cables, connection terminals of the device) are de-energized using suitable measuring equipment.

### WARNING

#### Explosion hazard due to high temperatures



High temperatures may cause the ignition of an explosive atmosphere.

Temperatures may occur within the device and the motor, which are higher than the maximum permissible surface temperature of the housing. Dust deposits may restrict the cooling of the device.

- Clean the device at regular intervals to prevent the accumulation of impermissible dust deposits.
- Do not open or remove the device from the motor in an explosive atmosphere.

### WARNING

#### Explosion hazard due to electrostatic charge



Electrostatic charges may cause sudden discharges with the formation of sparks. Sparks may ignite an explosive atmosphere.

The housing cover is made of plastic. This may become electrostatically charged, e.g. due to a flow of particles caused by the fan.

- Avoid air movement or air flows at the operating location of the device.

With appropriate modification, the device can be used in certain potentially explosive areas.

If the device is connected to a motor and a gear unit, the EX labeling of the motor and the gear unit must also be observed. Otherwise, operating the drive in this environment is unauthorized.

### Information

#### SK 2xxE, size 4

Size 4 devices (SK 2x0E-551-323 ... -112-323 and SK 2x0E-112-340 ... -222-340) are **not** approved for operation in potentially explosive environments.

### 2.6.1 Operation in potentially explosive environments - ATEX zone 22 3D

All of the conditions which must be observed for operation of the device in an explosion hazard environment (ATEX) are summarized below.

#### 2.6.1.1 Modification of the device for compliance with category 3D

Only a specially modified device is permissible for operation in ATEX zone 22. This adaptation is only made at the NORD factory. In order to use the device in ATEX zone 22, the diagnostic caps are replaced with anodized oil inspection glasses, among other things.



( 1 ) Year of manufacture

( 2 ) Labelling of the device (ATEX)

IP55:  II 3D Ex tc IIIB T125°C Dc X

IP66:  II 3D Ex tc IIIC T125°C Dc X

#### Allocation:

- Protection with "housing"
- Procedure "A" zone "22" category 3D
- IP55/IP66 rating (according to the device)
  - IP66 is required for conductive dust
- Maximum surface temperature 125°C
- Ambient temperature -20°C to +40°C

### Information

#### Possible damage caused by mechanical overload

Devices in series SK 2xxE and the permitted options are only designed for a degree of mechanical stress that corresponds to a low impact energy of 4J.

Higher loads will lead to damage to or in the device.

The components needed for the modification are contained in an appropriately modified variable frequency drive connection unit (SK TI4-...-EX).

### 2.6.1.2 Options for ATEX zone 22, category 3D

In order to ensure that the device is ATEX-compliant, its optional modules must also be approved for potentially explosive areas. Optional modules that are not in the following list may **not** be used in an ATEX zone 22 3D. This also includes connectors and switches that may also not be used in such an environment.

**Control and parameterization units** are basically **not** approved for **operation in ATEX - zone 22 3D**. They may therefore only be used for commissioning or maintenance purposes and if it has been ensured that there is no explosive dust atmosphere.

Designation	Material number	Use permissible
<b>Braking resistors</b>		
SK BRI4-1-100-100	275272005	Yes
SK BRI4-1-200-100	275272008	Yes
SK BRI4-1-400-100	275272012	Yes
SK BRI4-2-100-200	275272105	Yes
SK BRI4-2-200-200	275272108	Yes
<b>Bus interfaces</b>		
SK CU4-CAO(-C)	275271001 / (275271501)	Yes
SK CU4-DEV(-C)	275271002 / (275271502)	Yes
SK CU4-ECT(-C)	275271017 / (275271517)	Yes
SK CU4-EIP(-C)	275271019 / (275271519)	Yes
SK CU4-PBR(-C)	275271000 / (275271500)	Yes
SK CU4-PNT(-C)	275271015 / (275271515)	Yes
SK CU4-POL(-C)	275271018 / (275271518)	Yes
<b>IO -extensions</b>		
SK CU4-IOE(-C)	275271006 / (275271506)	Yes
SK CU4-IOE2(-C)	275271007 / (275271507)	Yes
SK CU4-REL(-C)	275271011 / (275271511)	Yes
<b>Power supply units</b>		
SK CU4-24V-123-B(-C)	275271108 / (275271608)	Yes
SK CU4-24V-140-B(-C)	275271109 / (275271609)	Yes
<b>Potentiometers</b>		
SK ATX-POT	275142000	Yes
<b>Miscellaneous</b>		
SK CU4-FUSE(-C)	275271122 / (275271622)	Yes
SK CU4-MBR(-C)	275271010 / (275271510)	Yes
<b>Wall mounting kits</b>		
SK TIE4-WMK-1-EX	275175053	Yes
SK TIE4-WMK-2-EX	275175054	Yes
<b>Adapter kits</b>		
SK TI4-12-Adapter kit_63_71-EX	275175038	Yes
SK TI4-3-Adapter kit_80_112-EX	275175039	Yes

### SK ATX-POT

The category 3D variable frequency drive can be equipped with an ATEX-compliant 10 k $\Omega$  potentiometer (SK ATX-POT) which can be used for setpoint (e.g. speed) adjustment on the device. The potentiometer is used with an M20-M25 extension in one of the M25 cable screw connections. The selected setpoint can be adjusted with a screwdriver. Due to the detachable cap, this component complies with ATEX requirements. Permanent operation may only be carried out with the cap closed.

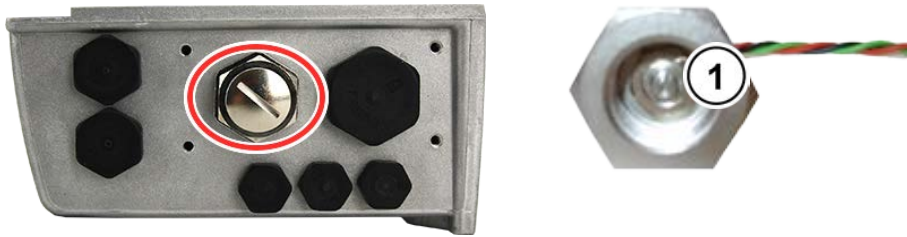

1 Setpoint adjustment using a screwdriver

SK ATX-POT wire color	Designation	Terminal SK CU4-24V...	Terminal SK CU4-IOE	Terminal SK 2x0E
Red	+10 V reference	[11]	[11]	[11]
Black	AGND/0 V	[12]	[12]	[12]/[40]
Green	Analog input	[14]	[14]/[16]	[14]/[16]

### Information

#### Internal braking resistor "SK BRI4-..."

If an internal braking resistor of type SK BRI4-x-xxx-xxx is used, activate the power limitation for this under all circumstances ( Section 2.3.1 "Internal braking resistor SK BRI4-..."). Only the resistors assigned to the relevant inverter type may be used.

### 2.6.1.3 Maximum output voltage and torque reduction

As the maximum achievable output voltage depends on the pulse frequency to be set, in some cases the torque which is specified in document [B1091-1](#) must be reduced for values above the rated pulse frequency of 6 kHz.

$$\text{For } F_{\text{pulse}} > 6 \text{ kHz:} \quad T_{\text{reduction}}[\%] = 1 \% * (F_{\text{pulse}} - 6 \text{ kHz})$$

Therefore, the maximum torque must be reduced by 1% for each kHz pulse frequency above 6 kHz. The torque limitation must be taken into account when reaching the breaking frequency. The same applies for the degree of modulation (P218). With the factory setting of 100%, a torque reduction of 5% must be taken into account in the field reduction range:

$$\text{For } P218 > 100\%: \quad T_{\text{reduction}}[\%] = 1 \% * (105 - P218)$$

No reduction needs to be taken into account above a value of 105%. However, with values above 105% no increase in torque above that of the Planning Guideline will be achieved. Under certain circumstances, degrees of modulation > 100% may lead to oscillations and motor vibration due to higher harmonics.

#### Information

#### Power derating

At pulse frequencies above 6 kHz (400 V devices) or 8 kHz (230 V) devices, the reduction in power must be taken into account for the design of the drive unit.

If parameter (P218) is set to < 105%, the derating of the degree of modulation must be taken into account in the field weakening range.

### 2.6.1.4 Commissioning information

For zone 22 the cable inlets must at least comply with the IP55 rating. Unused openings must be closed with blank screw caps that are suitable for ATEX zone 22 3D (generally IP66).

The motors are protected from overheating by the device. This takes place by means of evaluation of the motor PTC thermistor (TF) on the device. In order to ensure this function, the PTC thermistor must be connected to the intended input (terminal 38/39).



In addition, make sure to use a NORD motor from the motor list (P200). If a standard 4-pole NORD motor or a motor from a different manufacturer is not used, data for the motor parameters ((P201) to (P208)) must be adjusted to those on the motor nameplate. *The stator resistance of the motor (see P208) must be measured by the inverter and at ambient temperature. To do this, set parameter P220 to 1.* In addition, parameterize the variable frequency drive so that the motor can be operated with a maximum speed of 3000 rpm. For a four-pole motor, set the maximum frequency to a value that is less than or equal to 100 Hz ((P105) ≤ 100). Adhere to the maximum permissible output speed of the gear unit here. In addition, switch on I<sup>2</sup>t motor monitoring (parameter (P535)/(P533)) and set the pulse frequency to between 4 kHz and 6 kHz.



### Overview of required parameter settings:

Parameter	Setting value	Factory setting	Description
P105 maximum frequency	$\leq 100$ Hz	[50]	This value relates to a 4-pole motor. Basically, the value must only be so large that a motor speed of 3000 rpm is not exceeded.
P200 motor list	Select appropriate motor power	[0]	If a 4-pole NORD motor is used, the pre-set motor data can be called up.
P201 – P208 Motor data	Data according to nameplate	[xxx]	If a 4-pole NORD motor is not used, the motor data on the nameplate must be entered here.
P218 degree of modulation	$\geq 100\%$	[100]	Determines the maximum possible output voltage
P220 parameter identification	1	[0]	Measures the stator resistance of the motor. When the measurement is complete, the parameter is automatically reset to 0. The value that is determined is written to P208
P504 Pulse frequency	4 kHz ... 6 kHz	[6]	For pulse frequencies above 6 kHz a reduction of the maximum torque is necessary.
P533 $I^2t$ motor factor	$< 100\%$	[100]	A torque reduction can be taken into account with values less than 100 in $I^2t$ monitoring.
P535 $I^2t$ motor	According to motor and ventilation	[0]	The $I^2t$ monitoring of the motor must be switched on. The set values depend on the type of ventilation and the motor used, see <a href="#">B1091-1</a>

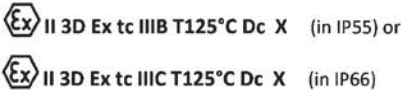
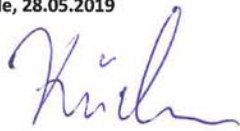
2.6.1.5 EU conformity declaration - ATEX

<p><b>GETRIEBEBAU NORD</b> Member of the NORD DRIVESYSTEMS Group</p>																						
<p><b>Getriebebau NORD GmbH &amp; Co. KG</b> Getriebebau-Nord-Str. 1, 22941 Bargteheide, Germany . Fon +49(0)4532 289 - 0 . Fax +49(0)4532 289 - 2253 . info@nord.com</p>																						
<p>C432710_2219</p>																						
<p><b>EU Declaration of Conformity</b> In the meaning of the directive 2014/34/EU Annex X, 2014/30/EU Annex II and 2011/65/EU Annex VI</p>																						
<p>Getriebebau NORD GmbH &amp; Co. KG as manufacturer in sole responsibility hereby declares, <span style="float: right;">Page 1 of 1</span> that the variable speed drives from the product series</p> <ul style="list-style-type: none"> <li>• <b>SK 200E-xxx-123-B-.. , SK 200E-xxx-323-.-.. , SK 200E-xxx-340-.-..</b> (xxx= 250, 370, 550, 750, 111, 151, 221, 301, 401, 551, 751) also in these functional variants: <b>SK 205E-... , SK 210E-... , SK 215E-... , SK 220E-... , SK 225E-... , SK 230E-... , SK 235E-...</b></li> </ul> <p>and the further options/accessories: <b>SK BRI4-..., SK ATX-POT, SK TIE4-M12-M16, SK TIE4-WMK-1, SK TIE4-WMK-2, SK CU4-PBR, SK CU4-CAO, SK CU4-DEV, SK CU4-PNT, SK CU4-ECT, SK CU4-POL, SK CU4-EIP, SK CU4-IOE</b></p> <p>with ATEX labeling </p> <p>comply with the following regulations:</p> <table style="width: 100%; border-collapse: collapse;"> <tr> <td style="width: 30%;"><b>ATEX Directive for products</b></td> <td style="width: 15%;"><b>2014/34/EU</b></td> <td style="width: 55%;">OJ. L 96 of 29.3.2014, p. 309–356</td> </tr> <tr> <td><b>EMC Directive</b></td> <td><b>2014/30/EU</b></td> <td>OJ. L 96 of 29.3.2014, p. 79–106</td> </tr> <tr> <td><b>RoHS Directive</b></td> <td><b>2011/65/EU</b></td> <td>OJ. L 174 of 1.7.2011, p. 88–11</td> </tr> <tr> <td><b>Delegated Directive(EU)</b></td> <td><b>2015/863</b></td> <td>OJ. L 137 of 4.6.2015, p. 10–12</td> </tr> </table> <p><b>Applied standards:</b></p> <table style="width: 100%; border-collapse: collapse;"> <tr> <td style="width: 33%;">EN 60079-0:2012+A11:2013</td> <td style="width: 33%;">EN 60079-31:2014</td> <td style="width: 33%;">EN 61800-9-1:2017</td> </tr> <tr> <td>EN 61800-5-1:2007+A1:2017</td> <td>EN 61800-3:2004+A1:2012+AC:2014</td> <td>EN 61800-9-2:2017</td> </tr> <tr> <td>EN 60529:1991+A1:2000+A2:2013+AC:2016</td> <td>EN 50581:2012</td> <td></td> </tr> </table> <p>It is necessary to notice the data in the operating manual to meet the regulations of the EMC-Directive. Specially take care about correct EMC installation and cabling, differences in the field of applications and if necessary original accessories.</p> <p>First marking was carried out in 2010.</p> <p><b>Bargteheide, 28.05.2019</b></p> <div style="display: flex; justify-content: space-around; margin-top: 20px;"> <div style="text-align: center;">  <p>U. Küchenmeister Managing Director</p> </div> <div style="text-align: center;">  <p>pp F. Wiedemann Head of Inverter Division</p> </div> </div>		<b>ATEX Directive for products</b>	<b>2014/34/EU</b>	OJ. L 96 of 29.3.2014, p. 309–356	<b>EMC Directive</b>	<b>2014/30/EU</b>	OJ. L 96 of 29.3.2014, p. 79–106	<b>RoHS Directive</b>	<b>2011/65/EU</b>	OJ. L 174 of 1.7.2011, p. 88–11	<b>Delegated Directive(EU)</b>	<b>2015/863</b>	OJ. L 137 of 4.6.2015, p. 10–12	EN 60079-0:2012+A11:2013	EN 60079-31:2014	EN 61800-9-1:2017	EN 61800-5-1:2007+A1:2017	EN 61800-3:2004+A1:2012+AC:2014	EN 61800-9-2:2017	EN 60529:1991+A1:2000+A2:2013+AC:2016	EN 50581:2012	
<b>ATEX Directive for products</b>	<b>2014/34/EU</b>	OJ. L 96 of 29.3.2014, p. 309–356																				
<b>EMC Directive</b>	<b>2014/30/EU</b>	OJ. L 96 of 29.3.2014, p. 79–106																				
<b>RoHS Directive</b>	<b>2011/65/EU</b>	OJ. L 174 of 1.7.2011, p. 88–11																				
<b>Delegated Directive(EU)</b>	<b>2015/863</b>	OJ. L 137 of 4.6.2015, p. 10–12																				
EN 60079-0:2012+A11:2013	EN 60079-31:2014	EN 61800-9-1:2017																				
EN 61800-5-1:2007+A1:2017	EN 61800-3:2004+A1:2012+AC:2014	EN 61800-9-2:2017																				
EN 60529:1991+A1:2000+A2:2013+AC:2016	EN 50581:2012																					

### 2.6.2 Operation in potentially explosive environments - EAC Ex

All of the conditions which must be observed for operation of the device in an explosion hazard environment according to EAC Ex are summarized below. The conditions according to  Section 2.6.1 "Operation in potentially explosive environments - ATEX zone 22 3D "apply .Deviations which are relevant for approval according to EAC Ex are described below and must be complied with.

#### 2.6.2.1 Modification of the device

 Section 2.6.1.1 applies.

Labeling of the device according to EAC EX deviates as follows.



The following applies for wall mounted devices:

IP55: Ex tc IIIB T125 °C Dc X

IP66: Ex tc IIIC T125 °C Dc X



For motor mounted devices, the following apply:

IP55: Ex tc IIIB Dc U

IP66: Ex tc IIIC Dc U

#### Allocation:

- Protection with "housing"
- Procedure "A" zone "22" category 3D
- IP55/IP66 rating (according to the device)
  - IP66 is required for conductive dust
- Maximum surface temperature 125°C
- Ambient temperature -20°C to +40°C

#### Information

#### Code "U"

Code "U" applies for devices which are intended for motor mounting. Devices which are so labeled are classed as incomplete and may only be operated together with a corresponding motor. If a device with code "U" is mounted on a motor, the codes and restrictions indicated on the motor or geared motor also apply.

#### Information

#### Code "X"

Code "X" indicates that the permissible ambient temperature range is between -20°C and +40°C.

### 2.6.2.2 Further information

Further information about explosion protection can be found in the following sections.

Description	Section
"Options for ATEX zone 22, category 3D"	2.6.1.2
"Maximum output voltage and torque reduction"	2.6.1.3
"Commissioning information"	2.6.1.4

### 2.6.2.3 EAC Ex Certificate

[TC RU C-DE.AA87.B.01109](#)

### 2.7 Outdoor installation

The device and the technology units (SK TU-...) can be installed outdoors under the following conditions:

- Design in IP66 (with UV-resistant blank screw caps, see special measures, Section 1.9 "Version with IP55/IP66 rating"),
- Anodized oil inspection glasses (part number: 201114000), quantity: 3,
- Cover the device to ensure that it is protected from the direct influence of weather (rain/sun),
- Accessories used (e.g. connectors), also at least IP66.



#### Information

##### Older devices

If older device models (year of manufacture 2010 or older) are to be retrofitted outdoors, it may also be necessary to replace the housing cover with a UV-resistant version. Please contact the Getriebbau NORD service department.

---

### 3 Display, operation and options

In the factory default configuration, without additional options, the diagnostic LEDs are externally visible. These indicate the actual device status. Two potentiometers (only SK 2x5E) and 8 DIP switches (S1) are provided in order to set the most important parameters. In this minimum configuration no other adapted parameters are stored in the external (plug-in) EEPROM. The only exception is data concerning operating hours, faults and fault circumstances. This data can only be saved in the external EEPROM (memory module) up to firmware version V1.2. As of firmware version 1.3, this data is saved in the internal EEPROM of the variable frequency drive.

The memory module (external EEPROM) can be pre-parameterized independently of the variable frequency drive using programming adapter SK EPG-3H.



Figure 18: SK 2xxE (size 1), top view



Figure 19: SK 2xxE (size 1), internal view

No.	Designation	SK 2x0E size 1 ... 3	SK 2x5E and SK 2x0E size 4
1	Diagnostic opening 1	RJ12 connection	RJ12 connection
2	Diagnostic opening 2	DIP switch AIN (250 Ω for current setpoint)	Diagnostic LEDs
3	Diagnostic opening 3	Diagnostic LEDs	Potentiometers (P1/P2)
4	8x DIP switches		
5	Plug-in EEPROM		

#### Information

##### Diagnostic caps' tightening torques

The tightening torque for the transparent diagnostic caps (inspection glasses) is 2.5 Nm.

#### 3.1 Control and parameterization options

Various control options are available that can be mounted directly to the device or in close proximity to it and directly connected.

Parameterization units also provide a facility for accessing and adjusting the parameters of the device.

Designation		Material number	Document
<b>Switches and potentiometers</b> (attachment)			
SK CU4-POT	Switch/Potentiometer	275271207	 Section 3.2.4 "Potentiometer adapter, SK CU4-POT"
SK TIE4-POT	Potentiometer 0-10 V	275274700	<a href="#">TI 275274700</a>
SK TIE4-SWT	L-OFF-R switch	275274701	<a href="#">TI 275274701</a>
<b>Control and parameterization units</b> (handheld)			
SK CSX-3H	Simple Box	275281013	<a href="#">BU0040</a>
SK PAR-3H	Parameter Box	275281014	<a href="#">BU0040</a>

### 3.1.1 Use of control and parameterization units

All parameters can be conveniently accessed for reading or editing by means of an optional Simple Box or Parameter Box. The modified parameter data is stored in the non-volatile EEPROM memory.

Up to 5 complete device data sets can be stored in the Parameter Box and then retrieved.

The Simple Box or the Parameter Box is connected to the device through an RJ12-RJ12 cable.



Figure 20: Simple Box, handheld, SK CSX-3H



Figure 21: Parameter Box, handheld, SK PAR-3H

Module	Description	Data
SK CSX-3H (handheld Simple Box)	Used for commissioning, parameterization, configuration and control of the device <sup>1)</sup> .	<ul style="list-style-type: none"> <li>• 4-digit, 7-segment LED display, membrane button</li> <li>• IP20</li> <li>• RJ12-RJ12 cable (connection to the device <sup>1)</sup>)</li> </ul>
SK PAR-3H (handheld Parameter Box)	Used for commissioning, parameterization, configuration and control of the variable frequency drive and its options (SK xU4-...). Entire parameter data sets can be stored.	<ul style="list-style-type: none"> <li>• 4-line backlit LCD display, membrane keys</li> <li>• Stores up to 5 complete parameter data sets</li> <li>• IP20</li> <li>• RJ12-RJ12 cable (connection to the device)</li> <li>• USB cable (connection to PC)</li> </ul>
1)	Does not apply to optional modules such as bus interfaces	

#### Connection

1. Remove diagnostics glass of the RJ12 socket.
2. Establish RJ12-RJ12 cable connection between control unit and **FEHLER - Variable ohne Inhalt**.

*When a diagnostics glass or a blind plug is open, make sure no dirt or moisture enters the device.*

3. After commissioning, screw the **diagnostics glass or blind plugs back in again** and make sure they are **tightly sealed** before starting regular operation.





#### Information

##### Diagnostic caps' tightening torques

The tightening torque for the transparent diagnostic caps (inspection glasses) is 2.5 Nm.

#### 3.1.2 Connection of multiple devices to one parameterization tool

Basically, it is possible to access several variable frequency drives via the **Parameter Box** or the **NORDCON software**. In the following example, communication is made via the parameterization tool by tunneling the protocols of the individual devices (max. 4) via the common system bus (CAN). The following points must be noted:

1 Physical bus structure:

Establish CAN connection (system bus) between the devices

2 Parameterization

Parameter		Settings on the VFD							
No.	Designation	VFD1	VFD2	VFD3	VFD4				
P503	Master function output	2 (system bus active)							
P512	USS address	0	0	0	0				
P513	Telegram time-out (s)	0.6	0.6	0.6	0.6				
P514	CAN baud rate	5 (250 kBaud)							
P515	CAN address	32	34	36	38				

3 Parameterization tool is usually connected to the **first** variable frequency drive via RS485 (e.g. via RJ12).

*Conditions/restrictions:*

Basically, all of the currently available variable frequency drives from NORD can communicate via a common system bus. When devices in the SK 5xxE model series are incorporated, the framework conditions described in the manual for the device series concerned must be noted.

## 3.2 Optional modules

The device can be easily adapted to various requirements by using function-extending modules and modules for display, control and parameterization.

Alphanumeric display and control modules (📖 Section 3.1 "Control and parameterization options ") can be used for simple commissioning by changing parameters. For more complex tasks, connection to a PC system can take place with the aid of the NORDCON parameterization software.

### 3.2.1 Internal customer units SK CU4-... (installation of modules)

Internal customer units allow the scope of functionality of devices to be extended without changing the size. The device provides one mounting slot for one appropriate option. If other optional modules are required, use the external technology units for these (📖 Section 3.2.2 "External technology units SK TU4-... (module attachment)").



Figure 22: internal customer units SK CU4 ... (example)

The bus interfaces require an external 24 V power supply and are therefore also ready for operation if the device is not supplied with line voltage. Parameterization and diagnosis of the bus interface is therefore possible independently from the variable frequency drive.

Designation *)		Material number	Document
<b>Bus interfaces</b>			
SK CU4-CAO(-C)	CANopen	275271001 / (275271501)	<a href="#">TI 275271001</a> / ( <a href="#">TI 275271501</a> )
SK CU4-DEV(-C)	DeviceNet	275271002 / (275271502)	<a href="#">TI 275271002</a> / ( <a href="#">TI 275271502</a> )
SK CU4-ECT(-C)	EtherCAT	275271017 / (275271517)	<a href="#">TI 275271017</a> / ( <a href="#">TI 275271517</a> )
SK CU4-EIP(-C)	Ethernet IP	275271019 / (275271519)	<a href="#">TI 275271019</a> / ( <a href="#">TI 275274519</a> )
SK CU4-PBR(-C)	PROFIBUS DP	275271000 / (275271500)	<a href="#">TI 275271000</a> / ( <a href="#">TI 275271500</a> )
SK CU4-PNT(-C)	PROFINET IO	275271015 / (275271515)	<a href="#">TI 275271015</a> / ( <a href="#">TI 275271515</a> )
SK CU4-POL(-C)	POWERLINK	275271018 / (275271518)	<a href="#">TI 275271018</a> / ( <a href="#">TI 275271518</a> )
<b>IO -Extensions</b>			
SK CU4-IOE(-C)		275271006 / (275271506)	<a href="#">TI 275271006</a> / <a href="#">TI 275271506</a>
SK CU4-IOE2(-C)		275271007 / (275271507)	<a href="#">TI 275271007</a> / <a href="#">TI 275271507</a>
SK CU4-REL(-C)		275271011 / (275271511)	<a href="#">TI 275271011</a> / <a href="#">TI 275271511</a>
<b>Power supply units</b>			
SK CU4-24V-123-B(-C)		275271108 / (275271608)	<a href="#">TI 275271108</a> / <a href="#">TI 275271608</a>
SK CU4-24V-140-B(-C)		275271109 / (275271609)	<a href="#">TI 275271109</a> / <a href="#">TI 275271609</a>
<b>Miscellaneous</b>			
SK CU4-FUSE(-C)	Fuse module	275271122 / (275271622)	<a href="#">TI 275271122</a> / <a href="#">TI 275271622</a>
SK CU4-MBR(-C)	El. brake rectifier	275271010 / (275271510)	<a href="#">TI 275271010</a> / <a href="#">TI 275271510</a>

\* All modules with designation **-C** have lacquered PCBs so that they can be used in IP6x devices.

### 3.2.2 External technology units SK TU4-... (module attachment)

External technology units allow the scope of functionality of the devices to be extended in a modular way.

Depending on the type of module, different versions are available (differentiated according to IP rating, with/without connector, etc.). They can be mounted directly on the device using the relevant connection unit or in the vicinity of the device using an optional wall mounting kit.

**Each SK TU4-... technology unit requires an associated SK TI4-TU-... connection unit.**



Figure 23: external technology units SK TU4-... (example)

With the bus modules or the I/O extension, it is possible to access the system bus via the RJ12 socket (behind a transparent screw gland (diagnostics glass)) and therefore access all active devices that are connected to it (variable frequency drives, other SK xU4 modules) using Parameter Box SK PAR-3H or a PC (NORDCON software).

The bus modules require a 24 V power supply. If the supply voltage is applied, then the bus modules are ready even if the variable frequency drive is not in operation.

Model	IP55	IP66	M12	Designation	Material number	Document
CANopen	X			SK TU4-CAO	275 281 101	<a href="#">TI 275281101</a>
		X		SK TU4-CAO-C	275 281 151	<a href="#">TI 275281151</a>
	X		X	SK TU4-CAO-M12	275 281 201	<a href="#">TI 275281201</a>
		X	X	SK TU4-CAO-M12-C	275 281 251	<a href="#">TI 275281251</a>
DeviceNet	X			SK TU4-DEV	275 281 102	<a href="#">TI 275281102</a>
		X		SK TU4-DEV-C	275 281 152	<a href="#">TI 275281152</a>
	X		X	SK TU4-DEV-M12	275 281 202	<a href="#">TI 275281202</a>
		X	X	SK TU4-DEV-M12-C	275 281 252	<a href="#">TI 275281252</a>
EtherCAT	X			SK TU4-ECT	275 281 117	<a href="#">TI 275281117</a>
		X		SK TU4-ECT-C	275 281 167	<a href="#">TI 275281167</a>
EtherNet / IP	X		X	SK TU4-EIP	275 281 119	<a href="#">TI 275281119</a>
		X	X	SK TU4-EIP-C	275 281 169	<a href="#">TI 275281169</a>
POWERLINK	X			SK TU4-POL	275 281 118	<a href="#">TI 275281118</a>
		X		SK TU4-POL-C	275 281 168	<a href="#">TI 275281168</a>
PROFIBUS DP	X			SK TU4-PBR	275 281 100	<a href="#">TI 275281100</a>
		X		SK TU4-PBR-C	275 281 150	<a href="#">TI 275281150</a>
	X		X	SK TU4-PBR-M12	275 281 200	<a href="#">TI 275281200</a>
		X	X	SK TU4-PBR-M12-C	275 281 250	<a href="#">TI 275281250</a>
PROFINET IO	X			SK TU4-PNT	275 281 115	<a href="#">TI 275281115</a>
		X		SK TU4-PNT-C	275 281 165	<a href="#">TI 275281165</a>
	X		X	SK TU4-PNT-M12	275 281 122	<a href="#">TI 275281122</a>
		X	X	SK TU4-PNT-M12-C	275 281 172	<a href="#">TI 275281172</a>
I/O extension	X			SK TU4-IOE	275 281 106	<a href="#">TI 275281106</a>
		X		SK TU4-IOE-C	275 281 156	<a href="#">TI 275281156</a>
	X		X	SK TU4-IOE-M12	275 281 206	<a href="#">TI 275281206</a>
		X	X	SK TU4-IOE-M12-C	275 281 256	<a href="#">TI 275281256</a>
<b>Required accessories (each module must have an associated connection unit)</b>						
Connection unit	X			SK TI4-TU-BUS	275 280 000	<a href="#">TI 275280000</a>
		X		SK TI4-TU-BUS-C	275 280 500	<a href="#">TI 275280500</a>
<b>Optional accessories</b>						
Wall mounting kit	X	X		SK TIE4-WMK-TU	275 274 002	<a href="#">TI 275274002</a>

Table 9: external bus modules and IO extensions SK TU4- ...

Model	IP55	IP66	Designation	Material number	Document
Power supply unit 24 V/1~ 230 V	X		SK TU4-24V-123-B	275 281 108	<a href="#">TI 275281108</a>
		X	SK TU4-24V-123-B-C	275 281 158	<a href="#">TI 275281158</a>
Power supply unit 24 V/1~ 400 V	X		SK TU4-24V-140-B	275 281 109	<a href="#">TI 275281109</a>
		X	SK TU4-24V-140-B-C	275 281 159	<a href="#">TI 275281159</a>
Potentiometer Box 1~ 230 V	X		SK TU4-POT-123-B	275 281 110	<a href="#">TI 275281110</a>
		X	SK TU4-POT-123-B-C	275 281 160	<a href="#">TI 275281160</a>
Potentiometer Box 1~ 400 V	X		SK TU4-POT-140-B	275 281 111	<a href="#">TI 275281111</a>
		X	SK TU4-POT-140-B-C	275 281 161	<a href="#">TI 275281161</a>
<b>Required accessories (each module must have an associated connection unit)</b>					
Connection unit	X		SK TI4-TU-NET	275 280 100	<a href="#">TI 275280100</a>
		X	SK TI4-TU-NET-C	275 280 600	<a href="#">TI 275280600</a>
<b>Optional accessories</b>					
Wall mounting kit	X	X	SK TIE4-WMK-TU	275 274 002	<a href="#">TI 275274002</a>

Table 10: external modules with power supply unit SK TU4-24V- .../SK TU4-POT- ...

Model	IP55	IP66	Designation	Material number	Document
Maintenance switch	X		SK TU4-MSW	275 281 123	<a href="#">TI 275281123</a>
		X	SK TU4-MSW-C	275 281 173	<a href="#">TI 275281173</a>
	X		SK TU4-MSW-RG	275 281 125	<a href="#">TI 275281125</a>
		X	SK TU4-MSW-RG-C	275 281 175	<a href="#">TI 275281175</a>
<b>Required accessories (each module must have an associated connection unit)</b>					
Connection unit	X		SK TI4-TU-MSW	275 280 200	<a href="#">TI 275280200</a>
		X	SK TI4-TU-MSW-C	275 280 700	<a href="#">TI 275280700</a>
<b>Optional accessories</b>					
Wall mounting kit	X	X	SK TIE4-WMK-TU	275 274 002	<a href="#">TI 275274002</a>

Table 11: external modules – maintenance switch SK TU4-MSW- ...

#### 3.2.3 Plug connector

The use of optionally available plug connectors for power and control connections not only makes it possible to replace the drive unit with almost no loss of time in case of servicing, but also minimizes the risk of installation errors when connecting the device. The most common plug connector versions are summarized below. The possible mounting locations on the device are listed in Section 2.2.1 "Optional slots on the device".

##### 3.2.3.1 Plug connectors for power connections

Various plug connectors are available for the motor or power supply connection.



Figure 24: Examples of devices with connectors for power connection

Three different connections are available, which can also be combined (example "-LE-MA"):

Mounting version	Meaning
... - LE	Power input
... - LA	Power output
... - MA	Motor output

**Plug connector (selection)**

Model	Data	Designation	Material No.	Document
Power input	500 V, 16 A	SK TIE4-HANQ8-K-LE-MX	275 135 030	<a href="#">TI 275135030</a>
Power input	500 V, 16 A	SK TIE4-HAN10E-M1B-LE	275 135 070	<a href="#">TI 275135070</a>
Power input	500 V, 16 A	SK TIE4-HAN10E-M2B-LE	275 135 000	<a href="#">TI 275135000</a>
Power input	690 V, 20 A	SK TIE4-QPD_3PE-K-LE	275 274 125	<a href="#">TI 275274125</a>
Power input	630 V, 16 A	SK TIE4-NQ16-K-LE	275 274 133	<a href="#">TI 275274133</a>
Power input + power outlet	400 V, 16 A	SK TIE4-2HANQ5-K-LE-LA	275 274 110	<a href="#">TI 275274110</a>
Power input + motor outlet	600 V, 16 A	SK TIE4-2HANQ5-M-LE-MA-001	275 274 123	<a href="#">TI 275274123</a>
Power output	500 V, 16 A	SK TIE4-HAN10E-M2B-LA	275 135 010	<a href="#">TI 275135010</a>
Power output	500 V, 16 A	SK TIE4-HANQ8-K-LA-MX	275 135 040	<a href="#">TI 275135040</a>
Motor output	500 V, 16 A	SK TIE4-HAN10E-M2B-MA	275 135 020	<a href="#">TI 275135020</a>
Motor output	500 V, 16 A	SK TIE4-HANQ8-K-MA-MX	275 135 050	<a href="#">TI 275135050</a>

** Information**

**Daisy-chaining of the line voltage**

Adhere to the permissible current load for connection terminals, plugs and supply cables when Daisy-chaining the line voltage. Noncompliance will result in thermal damage to live modules and their immediate vicinity.



#### 3.2.3.2 Plug connectors for control connection

Various M12 round plug connectors are available as flanged plugs or flanged sockets. The plug connectors are intended for installation in an M16 screw connection of the device or in that of an external technology unit. The degree of protection (IP67) of the plug connector only applies in the screwed state. Similarly to the use of coding pins/grooves, the color coding of the connectors (plastic unit inside and cover caps) is based on functional requirements and is intended to avoid erroneous operation.

Suitable expansion and reducer adapters are available for installation in an M12 or M20 screw connection.



#### **i** Information

#### Control unit overload SK 2x0E

The control unit of the device can be overloaded and destroyed if the 24 V DC supply terminals of the device are connected to another voltage source.

For this reason, make sure that any wires for the 24 V DC power supply are not connected to the device but are insulated accordingly particularly when installing plug connectors for the control connection (example of connector for system bus connection SK TIE4-M12-SYSS).

#### Plug connector (selection)

Model	Version	Designation	Material number	Document
Voltage supply	Connector	SK TIE4-M12-POW	275 274 507	<a href="#">TI 275274507</a>
Sensors/actuators	Socket	SK TIE4-M12-INI	275 274 503	<a href="#">TI 275274503</a>
Initiators and 24 V	Connector	SK TIE4-M12-INP	275 274 516	<a href="#">TI 275274516</a>
AS interface	Connector	SK TIE4-M12-ASI	275 274 502	<a href="#">TI 275274502</a>
AS interface – Aux	Connector	SK TIE4-M12-ASI-AUX	275 274 513	<a href="#">TI 275274513</a>
PROFIBUS (IN + OUT)	Connector + socket	SK TIE4-M12-PBR	275 274 500	<a href="#">TI 275274500</a>
Analog signal	Socket	SK TIE4-M12-ANA	275 274 508	<a href="#">TI 275274508</a>
CANopen or DeviceNet IN	Connector	SK TIE4-M12-CAO	275 274 501	<a href="#">TI 275274501</a>
CANopen or DeviceNet OUT	Socket	SK TIE4-M12-CAO-OUT	275 274 515	<a href="#">TI 275274515</a>
Ethernet	Socket	SK TIE4-M12-ETH	275 274 514	<a href="#">TI 275274514</a>
System bus IN	Connector	SK TIE4-M12-SYSS	275 274 506	<a href="#">TI 275274506</a>
System bus OUT	Socket	SK TIE4-M12-SYSM	275 274 505	<a href="#">TI 275274505</a>
HTL encoder	Socket	SK TIE4-M12-HTL	275 274 512	<a href="#">TI 275274512</a>
Safe stop	Socket	SK TIE4-M12-SH	275 274 509	<a href="#">TI 275274509</a>

### 3.2.4 Potentiometer adapter, SK CU4-POT

Part no.: 275 271 207

Digital signals R and L can be directly applied to the corresponding digital inputs 1 and 2 of the variable frequency drive.

The potentiometer (0 - 10 V) can be evaluated via an analog input of the variable frequency drive (if present) or via an I/O extension. An optional 24 V module (SK xU4-24V-...) also provides the possibility of converting analog setpoints to proportional pulses (frequencies). These pulses, in turn, can be evaluated via one of the digital inputs 2 or 3 (P420 [02]/[03] = 26/27) of the variable frequency drive in the form of a setpoint (P400 [-06]/[-07]).



Module		SK CU4-POT Part no.: 275 271 207)	Connection: Terminal No.			Function
Pin	Color		SK 2x0E	SK 2x5E		
			VFD	VFD	Power supply unit	
1	brown	24 V supply voltage	43		44	Rotary switch L - OFF - R
2	black	Enable R (e.g. DIN1)	21	21		
3	white	Enable L (e.g. DIN2)	22	22		
4	white	Access to AIN+	14		14	Potentiometer 10 kΩ
5	brown	Reference voltage 10 V	11		11	
6	blue	Analog ground AGND	12		12	

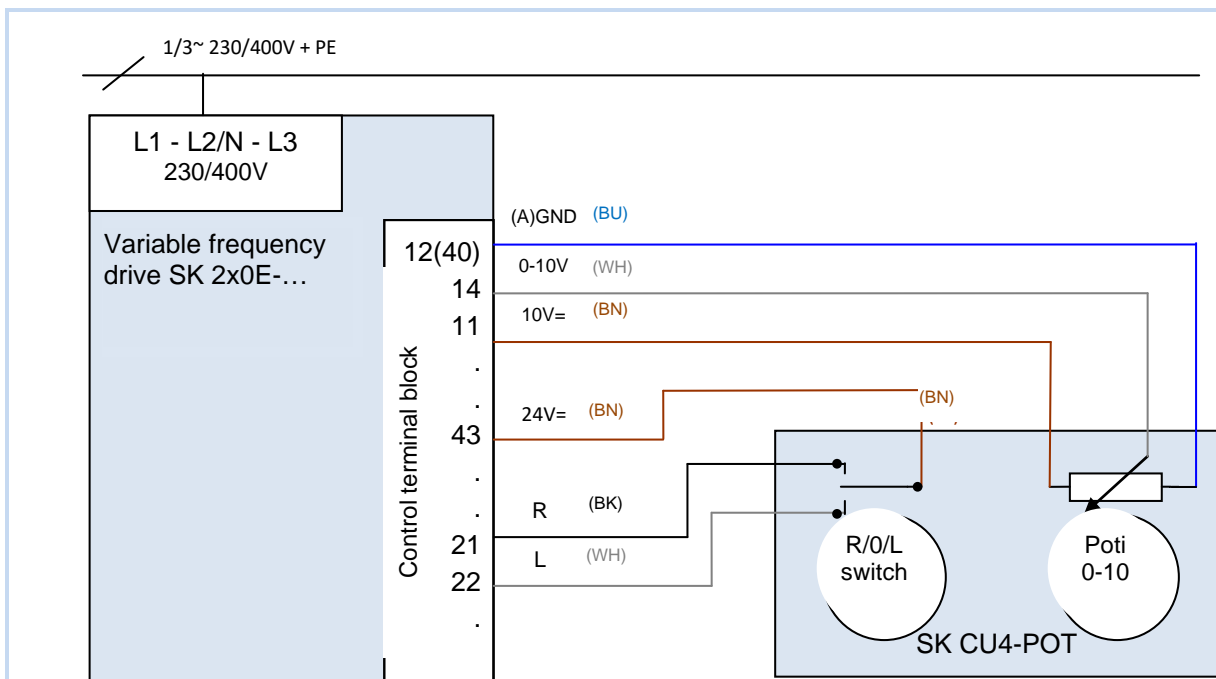

Figure 25: Connection diagram SK CU4-POT, example SK 2x0E

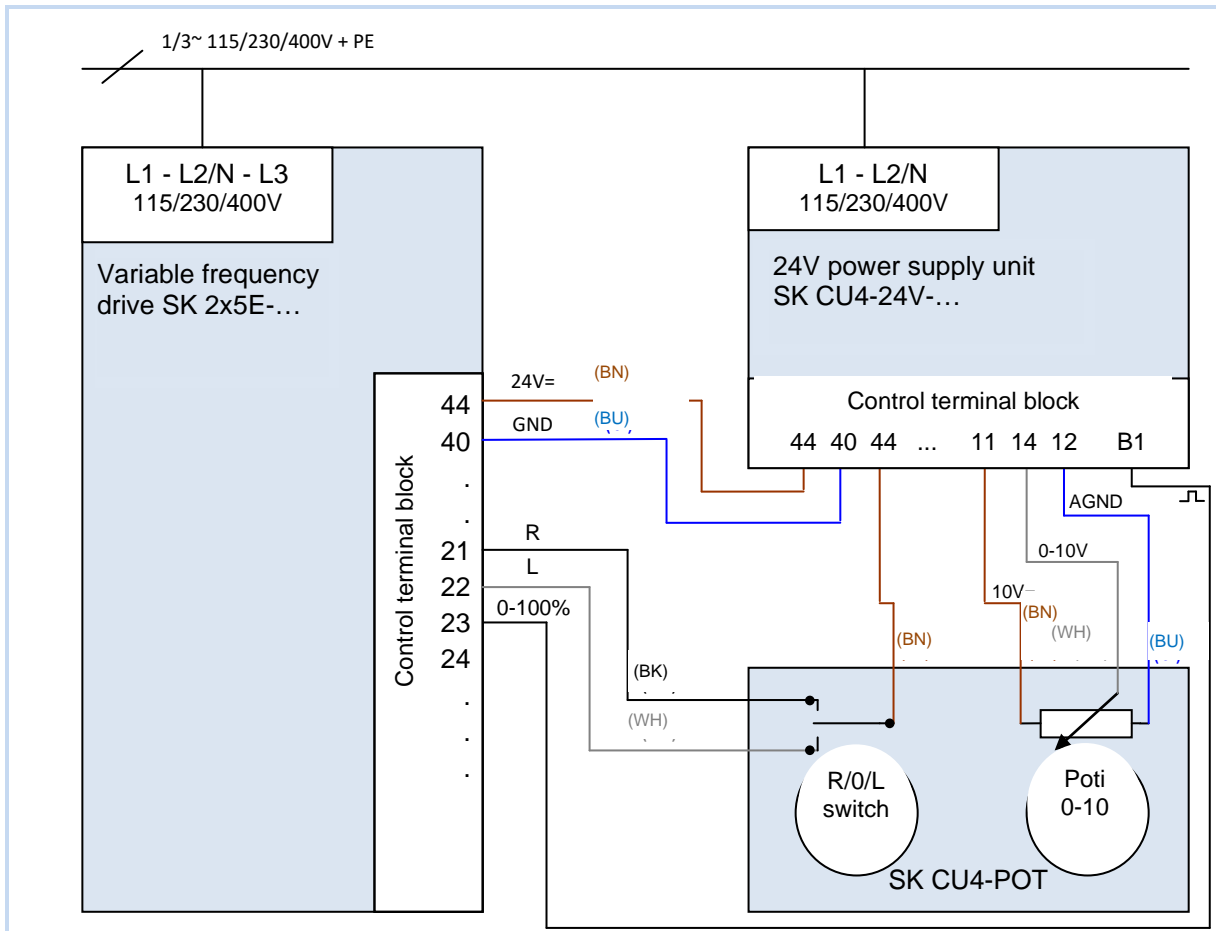

Figure 26: Connection diagram and parameterization of SK CU4-POT, example SK 2x5E

DIP switch settings (S1):

DIP3 = off, DIP4 = on, DIP5 = off (please see chapter 4.3.2.2 "DIP switches (S1)" on page 107)

**or**

Recommended parameter setting,  
S1: DIP1-8 = off

P400 [07] = 1      P420 [02] = 2  
P420 [01] = 1      P420 [03] = 26

## 4 Commissioning

### WARNING

#### Unexpected movement

Connection of the supply voltage may directly or indirectly set the device into motion. This may cause unexpected movement of the drive and the attached machine, which may result in serious or fatal injuries and/or material damage. Possible causes of unexpected movements are e.g.:

- Parameterization of an "automatic start"
  - Incorrect parameterization
  - Control of the device with an enabling signal from a higher level control unit (via I/O or bus signals)
  - Incorrect motor data
  - Incorrect encoder connection
  - Release of a mechanical holding brake
  - External influences such as gravity or other kinetic energy which acts on the drive unit
  - In IT systems: System fault (ground fault)
- To avoid any resulting hazard, the drive or drive chain must be secured against unexpected movements (mechanical blocking and/or decoupling, provision of protection against falling, etc.). In addition, make sure that there are no persons within the area of action and the danger area of the system.

### 4.1 Factory settings

All variable frequency drives supplied by Getriebebau NORD are pre-programmed with the default setting for standard applications with 4 pole standard motors (same voltage and power). When using motors with another output or number of poles, enter data from the nameplate of the motor in parameters **P201...P207** under the menu item >Motor data<.

All motor data (IE1, IE4) can be pre-set using parameter **P200**. After using this function, this parameter is reset to 0 = no change! The data is loaded automatically to parameters **P201...P209** and can be compared again with data on the motor nameplate.

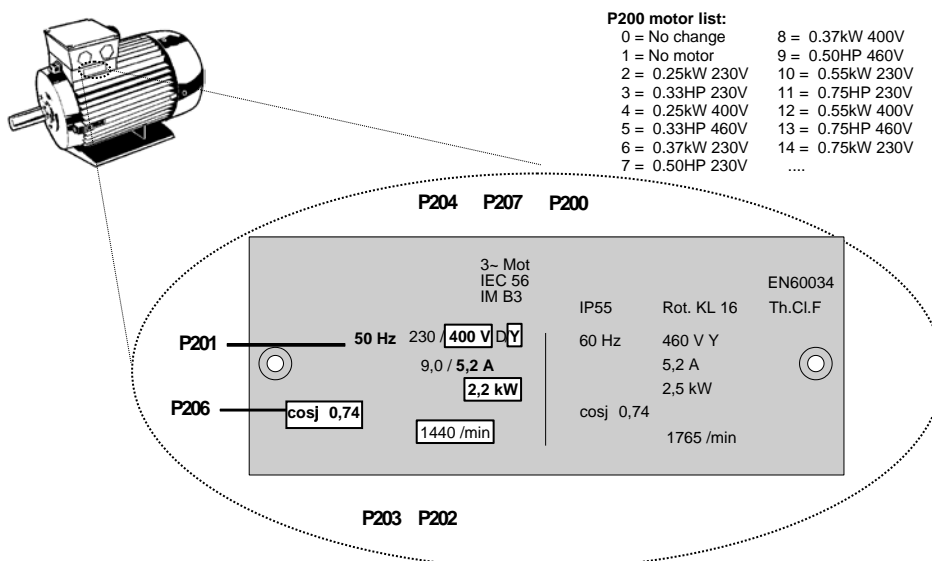

For the correct operation of the drive unit, it is necessary to input the motor data from the nameplate as precisely as possible. In particular, an automatic stator resistance measurement using parameter **P220** is recommended.

Motor data for IE2 / IE3 motors are provided via the **NORDCON** software. The required data record can be selected and imported into the variable frequency drive with the aid of the "Import motor parameter" function (also refer to the manual for the **NORDCON** software [BU 0000](#)).

### Information

#### DIN 2 and DIN 3 double allocation

Digital inputs DIN2 and DIN3 are used for 2 different functions:

1. for digital functions that can be parameterized (e.g. "enable left"),
2. for evaluation of an incremental encoder.

Both functions are coupled by an OR link.

Evaluation of an incremental encoder is always activated. This means that when an incremental encoder is connected, make sure that the digital functions are switched off (parameter (P420 [-02] and [-03]) or with DIP switch (please see chapter 4.3.2.2 "DIP switches (S1)" on page 107)).

### Information

#### DIP switch priority

Please note that DIP switch settings on the variable frequency drive (**S1**) have priority over parameter settings.

The settings of integrated potentiometers **P1** and **P2** must also be taken into consideration.

## 4.2 Selecting the operating mode for motor control

The variable frequency drive is able to control motors of all efficiency classes (IE1 to IE4). Motors which we manufacture are produced as asynchronous motors in efficiency classes IE1 to IE3, whereas IE4 motors are produced as synchronous motors.

Operation of IE4 motors has many special features with regard to the control technology. In order to achieve optimum results, the variable frequency drive was specially designed to control NORD IE4 motors whose construction corresponds to an IPMSM type (interior permanent-magnet synchronous motor). The permanent magnets in these motors are embedded in the rotor. NORD must check the operation of other brands if necessary. Please refer as well to Technical Information [TI 80-0010](#) "Planning and commissioning guidelines for NORD IE4 motors with NORD variable frequency drives".

### 4.2.1 Explanation of the operating modes (P300)

The variable frequency drive provides various operating modes to control a motor. All operating modes can be used with either an ASM (asynchronous motor) or a PMSM (permanent-magnet synchronous motor) but various constraints must be complied with. Basically, all methods are field-oriented control methods.

#### 1 VFC open-loop mode (P300, setting 0)

This operating mode is based on a voltage-governed, field-oriented control method (Voltage Flux Control Mode (VFC)). This is used for both ASMs as well as PMSMs. This is often referred to as "ISD control" in connection with the operation of asynchronous motors.

Control is carried out without the use of encoders and exclusively on the basis of fixed parameters and the measurement results of actual electrical values. No specific control parameter settings are necessary for the use of this mode. However, parameterization of precise motor data is an essential prerequisite for efficient operation.

As a special feature for the operation of an ASM, there is also the possibility of control according to a simple V/f characteristic curve. This mode of operation is important if several motors which are not mechanically coupled are to be operated with a single variable frequency drive, or if it is only possible to determine the motor data in a comparatively imprecise manner.

Operation according to a V/f characteristic curve is only suitable for drive applications with relatively low demands on the quality of speed control and dynamics (ramp times  $\geq 1$  s). For machines which tend to have relatively large mechanical vibrations due to their construction, control according to a V/f characteristic curve can also be advisable. Typically, V/f characteristic curves are used to control fans, certain types of pump drives or agitators. Operation according to a V/f characteristic curve is activated via parameters (P211) and (P212) (each set to 0).

## 2 CFC closed-loop mode (P300, setting 1)

In contrast to the 0 setting "VFC open-loop mode", this is a form of control with current-controlled field orientation (Current Flux Control). For this operating mode, which for ASMs is functionally identical to the previously used designation "servo control", use of an encoder is essential. The precise speed behavior of the motor is detected and included in the calculation for control of the motor. Determining the position of the rotor is also possible through the use of the encoder, whereby the initial value of the rotor position must also be determined for the operation of a PMSM. This enables even more precise and rapid control of the drive unit.

This operating mode provides the best possible results for the control behavior of both ASMs and PMSMs and is especially suitable for lifting equipment applications or applications with requirements for the highest possible dynamic behavior (ramp times  $\geq 0.05$  s). The greatest advantage of this operating mode is gained in combination with an IE4 motor (energy efficiency, dynamics, precision).

## 3 CFC open-loop mode (P300, setting 2)

The CFC mode is also possible with the open-loop method, i.e. operation without an encoder. Speed and position here are determined by "observation" of measurements and setting values. Precise setting of the current and speed controller is also essential for this operating mode. This mode is especially suitable for applications with higher demands for dynamics in comparison with VFC control (ramp times  $\geq 0.25$  s) and e.g. also for pump applications with high starting torques.

### 4.2.2 Overview of control parameter settings

The following provides an overview of all parameters which are of importance, depending on the selected operating mode. Among other things, a distinction is made between "relevant" and "important", which provides an indication of the required precision of the particular parameter setting. However, in principle, the more precisely the setting is made, the more exact the control, and the higher the values for dynamics and precision possible for the operation of the drive unit. A detailed description of these parameters can be found in Section 5 "Parameter".

		"∅" = Parameter has no significance		"-" = Leave the parameter in the factory setting			
		"√" = Setting of the parameter is relevant		"! " = Setting of the parameter is important			
Group	Parameter	Operating mode					
		VFC open-loop		CFC open-loop		CFC closed-loop	
		ASM	PMSM	ASM	PMSM	ASM	PMSM
Motor data	P201 ... P209	√	√	√	√	√	√
	P208	!	!	!	!	!	!
	P210	√ <sup>1)</sup>	√	√	√	∅	∅
	P211, P212	- <sup>2)</sup>	-	-	-	-	-
	P215, P216	- <sup>1)</sup>	-	-	-	-	-
	P217	√	√	√	√	∅	∅
	P220	√	√	√	√	√	√
	P240	-	√	-	√	-	√
	P241	-	√	-	√	-	√
	P243	-	√	-	√	-	√
	P244	-	√	-	√	-	√
	P246	-	√	-	√	-	√
P245, 247	-	√	∅	∅	∅	∅	
Controller data	P300	√	√	√	√	√	√
	P301	∅	∅	∅	∅	!	!
	P310 ... P320	∅	∅	√	√	√	√
	P312, P313, P315, P316	∅	∅	-	√	-	√
	P330 ... P333	-	√	-	√	-	√
	P334	∅	∅	∅	∅	-	√

<sup>1)</sup> = in V/f characteristic curve: precise setting of the parameter is important  
<sup>2)</sup> = in V/f characteristic curve: typical setting 0

### 4.2.3 Motor control commissioning steps

The most important commissioning steps are mentioned below in their ideal order. Correct assignment of the inverter/motor and the line voltage is assumed. Detailed information, especially for optimization of the current, speed and position control of asynchronous motors is described in the "Control Optimization" guide (AG 0100). Detailed commissioning and optimization information for PMSM in CFC closed loop mode can be found in the "Drive Optimization" guide (AG 0101). Please contact our Technical Support.

1. Carry out the motor connection as usual (note  $\Delta/Y!$ ). Connect the encoder, if present
2. Connect the power supply
3. Carry out the factory setting (P523)
4. Select the basic motor from the motor list (P200) (ASM types are at the beginning of the list, PMSM types are at the end, designated by their type (e.g. ...**80T**...))
5. Check the motor data (P201 ... P209) and compare with the nameplate/motor data sheet
6. Measure the stator resistance (P220) → P208, P241[-01] are measured, P241[-02] is calculated. (Note: if an SPMSM is used, P241[-02] must be overwritten with the value from P241[-01])
7. Rotary encoder: Check the settings (P301, P735)
8. with PMSM only:
  - a. EMF voltage (P240) → motor nameplate/motor data sheet
  - b. Determine/set reluctance angle (P243) (not required with NORD motors)
  - c. Peak current (P244) → motor data sheet
  - d. Only for PMSMs in VFC mode:  
determine (P245), (P247)
  - e. Determine (P246)
9. Select the operating mode (P300)
10. Determine/adjust the current controller (P312 ... P316)
11. Determine/adjust the speed controller (P310, P311)
12. PMSM only:
  - a. Select the control method (P330)
  - b. Enter the settings for starting behavior (P331 ... P333)
  - c. Enter the settings for the 0 pulse of the encoder (P334 ... P335)
  - d. Activation of slip error monitoring (P327  $\neq$  0)



#### Information

Please refer to Technical Information [TI80\\_0010](#) for further information on the commissioning of NORD IE4 motors with NORD variable frequency drives.



### 4.3 Starting up the device

The variable frequency drive can be commissioned in various ways:

- a) For simple applications (e.g conveyor applications) by means of the DIP switches (S1) integrated in the variable frequency drive (internal) and the externally accessible potentiometers (SK 2x5E only).

The plug-in EEPROM is not required in this configuration.

- b) By changing parameters with the control and parameterization unit (SK CSX-3H or SK PAR-3H) or the NORD CON PC-supported software.

The changes to the parameters in the plug-in EEPROM (memory module) are stored when doing this. Data is automatically saved in the internal EEPROM if no EEPROM is plugged in as of firmware **V1.3**.

Data is generally stored in the internal EEPROM as of firmware **V1.4 R2**. Data is stored in parallel on the external EEPROM.

For older firmware versions an external EEPROM must always be plugged in during operation in order to save changed parameter values permanently.



#### Information

#### Presetting of physical I/O and I/O bits

For commissioning standard applications, a limited number of the variable frequency drive inputs and outputs (physical and I/O bits) have predefined functions. These settings may need to be changed (parameters (P420), (P434), (P480), (P481)).

#### 4.3.1 Connection

In order to provide basic operational capability, connect the power and motor lines to the relevant terminals after the device is mounted on the motor or the wall mounting kit ( Section 2.4.2 "Electrical connection of power unit").

**SK 2x5E:** It is also essential for the device to be provided with a 24 V DC control voltage.



#### Information

#### Control voltage SK 2x5E:

The required 24 V control voltage can be implemented by means of an integrated (SK CU4-24V-...) or external (SK TU4-24V-...) optional power module or a comparable 24 V DC power source ( Section 2.4.3 "Electrical connection of the control unit").

### 4.3.2 Configuration

Changes to individual parameters are usually necessary for operation.

However, configuration can be carried out to a limited extent by means of the integrated 8-pole DIP switch (S1).



#### Information

#### Configuration via DIP switch

Avoid mixing DIP switch configuration and (software) parameterization.

#### 4.3.2.1 Parameterization

The use of a Parameter Box (SK CSX-3H/SK PAR) or the NORDCON- software is required in order to adapt the parameters.

Parameter group	Parameter numbers	Functions	Comments
Basic parameters	P102 ... P105	Ramp times and frequency limits	
Motor data	P201 ... P207, (P208)	Data on motor nameplate	
	P220, function 1	Measure stator resistance	Value is written to P208
	alternatively P200	Motor data list	Selection of a 4-pole standard NORD motor from a list
	alternatively P220, function 2	Motor identification	Complete measurement of a connected motor Prerequisite: Motor no more than 3 power levels less than the variable frequency drive
Control terminals	P400, P420	Analog and digital inputs	



#### Information

#### Factory settings

Prior to commissioning, make sure the variable frequency drive is in its factory settings (P523).

If configuration is carried out at parameter level, the DIP- switches (S1) must also be set to the 0 (OFF) position.

### 4.3.2.2 DIP switches (S1)

These DIP switches make it possible to carry out commissioning without additional control units. Further settings are entered through the potentiometer on top of the variable frequency drive (P1/P2, SK 2x5E only).

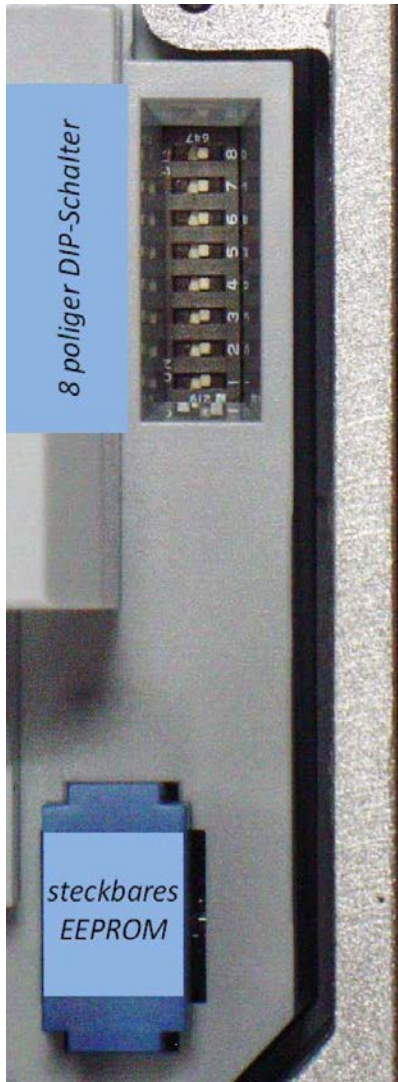

No.	DIP switch (S1)		
Bit			
8 2 <sup>7</sup>	<b>Int R<sub>Brake</sub></b> Internal braking resistor	0	Internal brake resistor not existing
		1	Internal brake resistor existing (📖 Section 2.3.1)
7 2 <sup>6</sup>	<b>60 Hz</b> <sup>1)</sup> 50/60 Hz operation	0	Motor data corresponding to the rated power of the VFD in kW relative to 50 Hz, f <sub>max</sub> = 50 Hz
		1	Motor data corresponding to the rated power of the VFD in hp relative to 60 Hz, f <sub>max</sub> = 60 Hz
6 2 <sup>5</sup>	<b>COPY</b> <sup>2)</sup> EEPROM copy function	0	No function
		1	EEPROM copy function active, once
5/4 2 <sup>4/3</sup>	<b>I/O</b> Potentiometer function, digital inputs and AS interface	<b>DIP No.</b> 5 4	
		0 0	Corresponding to P420 [1-4] and P400 [1-2] or P480 [1-4] and P481 [1-4]
		0 1	Further details in the next table. (depends on the DIP3 "BUS")
		1 0	
3 2 <sup>2</sup>	<b>BUS</b> Source control word and setpoint	0	Corresponding to P509 and P510 [1] [2]
		1	System bus (⇒ P509=3 and P510=3)
2/1 2 <sup>1/0</sup>	<b>ADR</b> System bus address/ baud rate	<b>DIP No.</b> 2 1	
		0 0	Corresponding to P515 and P514 [32, 250 kBaud]
		0 1	Address 34, 250 kBaud
		1 0	Address 36, 250 kBaud
		1 1	Address 38, 250 kBaud
<p>1) A changed setting is applied the next time the power supply is switched on. Existing settings in parameters P201-P209 and P105 are overwritten!</p> <p>2) up to firmware version 1.4 R1 the DIP switch designation was <b>U/F</b>. A changeover between the control procedures (U/F/ISD control) has been made possible via the DIP switch.</p>			

### Information

### Factory setting, as delivered

In the factory setting configuration, all DIP switches are in the 0 (off) position. Actuation takes place using the digital control signals (P420 [01]-[04]) and potentiometers P1 and P2 integrated in the VFD (P400 [01]-[02]) (P1/P2 with SK 2x5E only).

### Information

### IO bit factory settings:

To control the variable frequency drive via In/Out bits (e.g.: AS-i, DIG In 1 - 4) typical values are pre-set in the relevant parameters (P480) and (P481) (details: 📖 Section 5 "Parameter").

**These settings apply to both control via AS-i bits and BUS I/O bits.**

**Details of DIP switch S1: 5/4 and 3**

**Applies to devices SK 20xE, SK 21xE (without on-board AS interface)**

DIP			Functions as per the list of digital functions (P420)				Functions as per the list of analog functions (P400)	
5	4	3	Dig 1	Dig 2	Dig 3	Dig 4**	Poti 1***	Poti 2***
off	off	off	<u>P420 [01]*</u> {01} "Enable R"	<u>P420 [02]*</u> {02} "Enable L"	<u>P420 [03]*</u> {04} "fixed freq 1" =5 Hz (P465[01])	<u>P420 [04]*</u> {05} "fixed freq 2" =10 Hz (P465[02])	<u>P400 [01]*</u> {01} "F setpoint"	<u>P400 [02]*</u> {15} "ramp"
off	on	off	{01} "Enable R"	{02} "Enable L"	{26} "F setpoint"***	{12} "Quit"	{05} "F max"	{04} "F min"
on	off	off	{45} "3-on"	{49} "3-off"	{47} "Freq. +"	{48} "Freq. -"	{05} "F max"	{15} "Ramp"
on	on	off	{50} "F Arr Bit0" =5Hz (P465[01])	{51} "F Arr Bit1" =10 Hz (P465[02])	{52} "F Arr Bit2" =20 Hz (P465[03])	{53} "F Arr Bit3" =35 Hz (P465[04])	{05} "F max"	{15} "Ramp"
off	off	on	The functions of the digital inputs are inactive (control via system bus) but the settings entered in the parameters (P420 [01 ... 04]) for functions designated with .2 in the function list (e.g.: {11} <sup>2</sup> = "quick stop") result in the activation of the correspondingly parameterized input.				<u>P400 [01]</u> {01} "F setpoint"	<u>P400 [02]</u> {15} "ramp"
off	on	on	<u>P420 [01]</u> no function	<u>P420 [02]</u> no function	<u>P420 [03]</u> {04} "fixed freq1" =5 Hz (P465[01])	<u>P420 [04]</u> {05} "fixed freq2" =10 Hz (P465[02])	{01} "F setpoint"	{05} "F max"
on	off	on	{14} "Remote control"	"Encoder track A"	"Encoder track B"	{01} "Enable R"	{01} "F setpoint"	{05} "F max"
on	on	on	{14} "Remote control"	{01} "Enable R"	{10} "Block"	{66} "Release brake"	{01} "F setpoint"	{05} "F max"
on	on	on	{14} "Remote control"	{51} "F Arr Bit1" =10 Hz (P465[02])	{52} "F Arr Bit2" =20 Hz (P465[03])	{53} "F Arr Bit3" =35 Hz (P465[04])	{05} "F max"	{15} "Ramp"

**Explanation:** (values underlined in brackets) = (relevant parameter/source of function), e.g.: **Parameter (P420[01])**

{curly brackets} = {function} e.g.: {01} "Enable right"

\* Default setting

\*\* only if present (devices without "safe stop" function)

\*\*\* only with SK 2x5E

**Applies to devices SK 22xE, SK 23xE (without AS interface on board)**

DIP			Functions as per the list of digital functions (P420)				Functions as per the list of digital outputs (P434)			
5	4	3	ASi In1	ASi In2	ASi In3	ASi In4	ASi Out1	ASi Out2	ASi Out3	ASi Out4
off	off	off	<u>P480 [01]*</u> {01} "Enable L"	<u>P480 [02]*</u> {02} "Enable L"	<u>P480 [03]*</u> {04} "Fixed freq. 1" =5 Hz (P465[01])	<u>P480 [04]*</u> {12} "Quit"	<u>P481 [01]*</u> {07} "Error"	<u>P481 [02]*</u> {18} "Ready"	"DigIn1"	"DigIn2"
off	on	off	{04} "Fixed freq. 1"=5 Hz (P465[01])	{05} "Fixed freq. 2"=10 Hz (P465[02])	{06} "Fixed freq. 3"=20 Hz (P465[03])	{07} "Fixed freq. 4"=35 Hz (P465[04])	{07} "Error"	{18} "Ready"	"DigIn1"	"DigIn2"
on	off	off	{01} "Enable R"	{02} "Enable L"	{47} "Freq. +"	{48} "Freq. -"	{07} "Error"	{18} "Ready"	"DigIn1"	"DigIn2"
on	on	off	{51} "F Arr B1" =10 Hz (P465[02])	{52} "F Arr B2" =20 Hz (P465[03])	{53} "F Arr B3" =35Hz (P465[04])	{14} "Remote control"	{07} "Error"	{18} "Ready"	"DigIn1"	"DigIn2"
off	off	on	The functions of the ASI-In bits are inactive (control via system bus) but the settings entered in the parameters (P480 [01 ... 04]) for functions designated with .2 in the function list (e.g.: {11} <sup>2</sup> = "quick stop") result in the activation of the correspondingly parameterized bit				<u>P481 [01]</u> {07} "Error"	<u>P481 [02]</u> {18} "Ready"	"DigIn1"	"DigIn2"
off	on	on	<u>P480 [01]</u> no function	<u>P480 [02]</u> no function	<u>P480 [03]</u> <sub>set</sub> {04} "Fixed freq. 1"=5 Hz (P465[01])	<u>P480 [04]</u> {12} "Quit"	{07} "Error"	{18} "Ready"	"DigIn1"	"DigIn2"
on	off	on	{14} "Remote control"	{04} "Fixed freq. 1"=5 Hz (P465[01])	{05} "Fixed freq. 2"=10 Hz (P465[02])	{06} "Fixed freq. 3"=20 Hz (P465[03])	{07} "Error"	{18} "Ready"	"DigIn1"	"DigIn2"
on	on	on	{14} "Remote control"	{01} "Enable R"	{47} "Freq. +"	{48} "Freq. -"	{07} "Error"	{18} "Ready"	"DigIn1"	"DigIn2"
on	on	on	{14} "Remote control"	{50} "F Arr B0" =5Hz (P465[01])	{51} "F Arr B1" =10 Hz (P465[02])	{52} "F Arr B2" =20Hz (P465[03])	{07} "Error"	{18} "Ready"	"DigIn1"	"DigIn2"

**Explanation:** See table above

**Note:**

The functions of potentiometers\*\*\* P1 and P2 correspond to those of devices without an AS interface (see table above).

With DIP switches 5 and 4 in the OFF position (default setting), the digital inputs are also active. The functions then correspond to those of devices without an AS interface (table above). In all other DIP switch combinations the functions of the digital inputs are deactivated.

ASI OUT1 and ASI OUT2 loop the signal level (High/Low) of digital inputs 1 and 2.



### 4.3.2.3 DIP switches, analog input (only SK 2x0E)

The analog inputs in the SK 2x0E are suitable for current and voltage setpoints. For correct processing of current setpoints (0-20 mA/4-20 mA) the relevant DIP switch must be set for current signals ("ON").

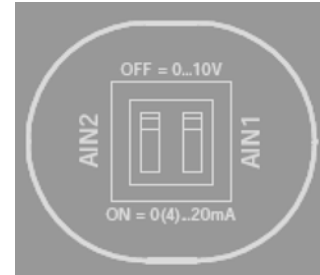
Adjustment to wire-break-proof signals (2-10 V/4-20 mA) is made via parameters (P402) and (P403).



#### Access to DIP switches

SK 2x0E	Access	Detail
Size 1 ... 3	... from outside, middle diagnostic opening	
Size 4	... from inside	

#### 4.3.2.4 Potentiometers P1 and P2 (SK 2x0E size 4 and SK 2x5E)

The setpoint can be set to a fixed value with integrated potentiometer P1. Adjustment of startup and braking ramps can be made via potentiometer P2.



#### Potentiometers

P1 (continuous)			P2 (stepped)		
0%	P102/103	P105	-	-	-
10%	0.2 s	10 Hz	1	P102/103	P104
20%	0.3 s	20 Hz	2	0.2 s	2 Hz
30%	0.5 s	30 Hz	3	0.3 s	5 Hz
40%	0.7 s	40 Hz	4	0.5 s	10 Hz
50%	1.0 s	50 Hz	5	0.7 s	15 Hz
60%	2.0 s	60 Hz	6	1.0 s	20 Hz
70%	3.0 s	70 Hz	7	2.0 s	25 Hz
80%	5.0 s	80 Hz	8	3.0 s	30 Hz
90%	7.0 s	90 Hz	9	5.0 s	35 Hz
100%	10.0 s	100 Hz	10	7.0 s	40 Hz

The function of P1 and P2 depends on DIP 4/5. The meaning changes according to the setting.  
By default, P1 sets the setpoint value of 0%-100% and P2 sets the ramp from 0.2-7 s.



### 4.3.3 Plug-in EEPROM (memory module)

The variable frequency drive is equipped with an internal EEPROM and a plug-in EEPROM (memory module) which operates in parallel to this for the storage and management of parameter data. Data from the device is managed in parallel on both devices so that safe and rapid exchange of parameter settings in the device is possible during commissioning or service.

#### 4.3.3.1 Replacing the plug-in EEPROM (memory module)

A decisive advantage during servicing the SK 2xxE is the simple transfer of data from a failed variable frequency drive to the replacement device. However, the following must be noted when exchanging data via the plug-in EEPROM:

- The data transfer must be deliberately activated (📖 Section 4.3.3.2 "Copy function").
- Any restrictions which exist due to the change between devices from different generations must be noted.

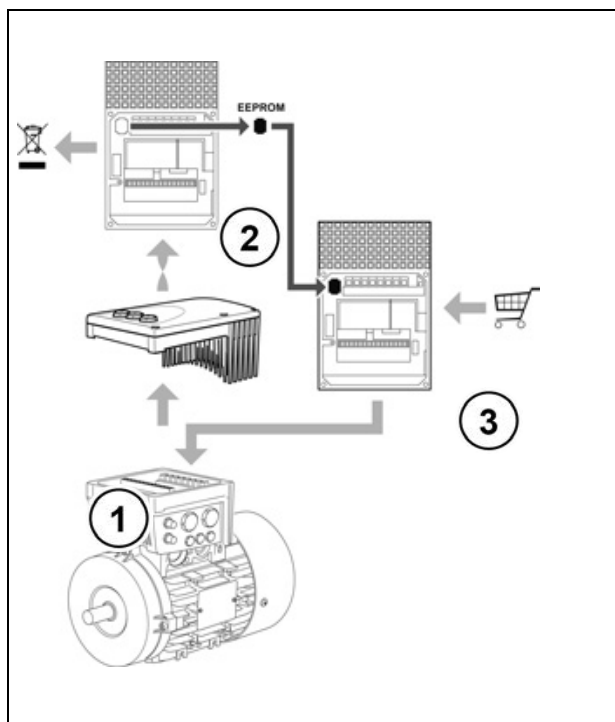

The plug-in EEPROM is located on the underside of the device.

Access to the EEPROM is enabled by removing the defective variable frequency drive (2) from the connection unit (1). The EEPROM is unlocked by lightly compressing the tabs on the short sides and then pulling it out.

The EEPROM must be inserted into the new device. The EEPROM is correctly seated when the lock audibly engages. It is not possible to insert the EEPROM so that it is laterally reversed.

(1)	Connection unit
(2)	Variable Frequency Drive defective
(3)	Variable Frequency Drive, replacement device

Figure 27: Replacing the plug-in EEPROM

Devices from hardware version **EAA** have a more efficient processor than 1st generation devices (hardware version "AAA"). This includes a larger range of functions, e.g. integrated PLC functionality (SPS function) and operation of PMSMs.

In order to manage the larger amount of data, the capacity of the plug-in EEPROM (memory module) has been extended. EEPROMs with the larger memory capacity can be identified from an additional raised marking ("II") on the housing. Alternatively, an adhesive label with "V2" may be applied.



### Downward compatibility:

In principle, it is permissible to operate older-generation variable frequency drives with an EEPROM from a newer generation and vice versa.

### Please note:

Before the exchange of data, in addition to the firmware status (software versions) of the two variable frequency drives, it is also necessary to compare the hardware versions of the variable frequency drives and the EEPROMS, because:

- Variable Frequency Drives with the hardware status "EAA" can **only read** data from a first generation EEPROM (EEPROM without label). The EEPROM cannot be written by the variable frequency drive so that parameter changes are only saved in the device itself and are no longer saved in the EEPROM.
- Variable Frequency Drives with the hardware status "AAA" can read and write data from a second generation EEPROM (EEPROM with label). However, only data saved on the EEPROM which can be processed by the variable frequency drive due to its older construction status is used (incompatibility).

---

## Information

## Incompatibility

During the transfer of data records between devices with different firmware statuses (software versions) in which the replacement device has an older status than the defective device, incompatibilities between individual functions may occur. Because of this, we recommend that the firmware be updated to the currently available software status for the device generation.

---

After the data transfer we recommend that the EEPROM included in the scope of delivery of the device be re-inserted in the replacement device and data from the device be copied to the EEPROM.

### 4.3.3.2 Copy function

The copy function is located in parameter P550 and is described in detail in the manual. In addition, a copy function is available, which is triggered independently from parameter P550, simply by setting a DIP switch.

### 4.3.3.3 Copy function DIP switches S1 – 6 "COPY"

Transferring data from the external to the internal EEPROM has been made even simpler through the new function of the DIP switch element S1-6 ("COPY").

If a 0 → 1 flank is detected on DIP switch element S1-6 when the variable frequency drive is restarted, copying of data from the plug-in EEPROM to the internal EEPROM is triggered.

The copying process takes several seconds. During the copying process, the status LED rapidly flashes red-green alternately.

- If an error is detected during copying of data, the process is interrupted and an error message (E008.2 "External copying error") is generated.
- If no plug-in EEPROM is detected (not available or defective), the process is interrupted and an error message (E008.2 "External copying error") is generated.
- Interruption of data transfer, e.g. due to premature switch-off of the line voltage or the control voltage of the inverter, interrupts the copying process. **No error message is generated!** The interruption can only be identified by checking the parameter settings of the variable frequency drive.

If necessary, the copying process must be repeated.



### Starting the copy function

To start the copy function, set DIP switch S1-6 "COPY" from position { 0 } (factory setting) to position { 1 }. A 0 → 1 flank is detected here and the copying process is started at the next start of the variable frequency drive.

- 1 Set DIP switch S1-6 "COPY" to { 1 },
- 2 Switch on the variable frequency drive ("POWER ON" (24 V)).
- 3 → The copying process starts.

*The copying process is not restarted without a previous change to the DIP switch.*

Carry out the following steps to trigger the process again:

- 1 Set DIP switch S1-6 "COPY" to { 0 },
- 2 Switch on the variable frequency drive ("POWER ON" (24 V)),
- 3 Switch off the variable frequency drive ("POWER OFF" (24 V)),
- 4 Set DIP switch S1-6 "COPY" to { 1 },
- 5 Switch on the variable frequency drive ("POWER ON" (24 V)).
- 6 → The copying process starts.

---

### Information

### Parameter P550

The COPY function of DIP switch S1-6 "COPY" is comparable to parameter function P550 ("EEPROM copy order" setting { 1 } "Ext. → Int. EEPROM"). This function is still available.

---

### 4.3.4 Commissioning examples

All SK 2xxE devices can basically be operated in the condition in which they are delivered. Standard motor data of a standard NORD 4-pole asynchronous motor of the same power is parameterized. The PTC input must be bypassed if no motor PTC is available. Parameter (P428) must be changed if an automatic startup with "Power On" is required.

#### 4.3.4.1 SK 2x0E minimum configuration

The variable frequency drive provides all the necessary control voltages (24 VDC/10 VDC).

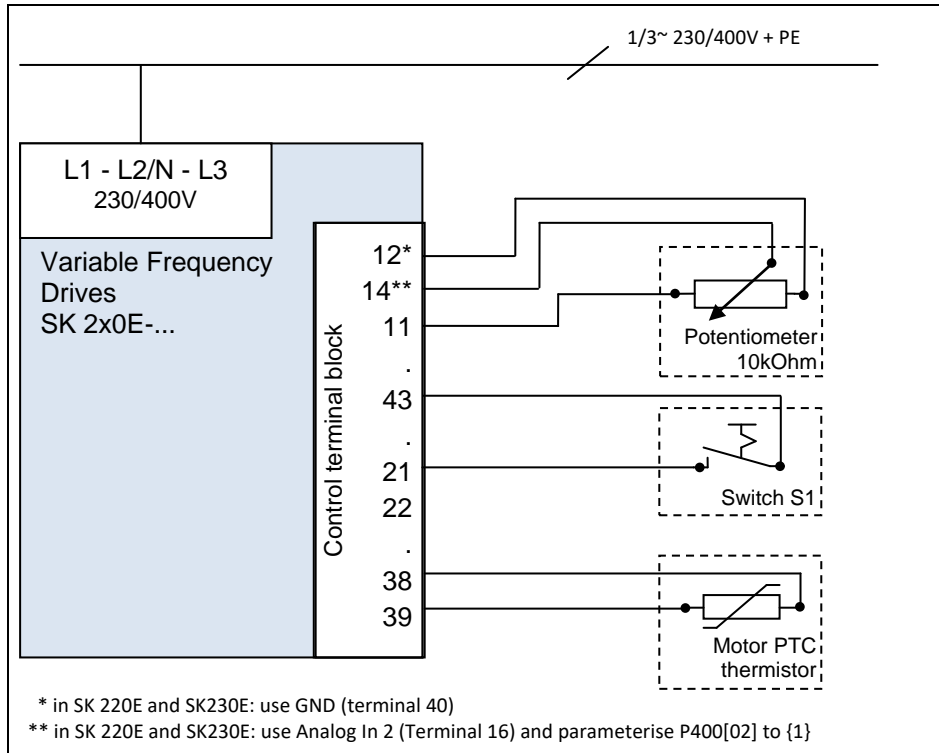

Function	Setting
Setpoint	External 10 kΩ potentiometer
Controller enable	External switch S1

### 4.3.4.2 SK 2x5E minimum configuration

#### Minimal configuration without options

The variable frequency drive must be provided with an external control voltage.

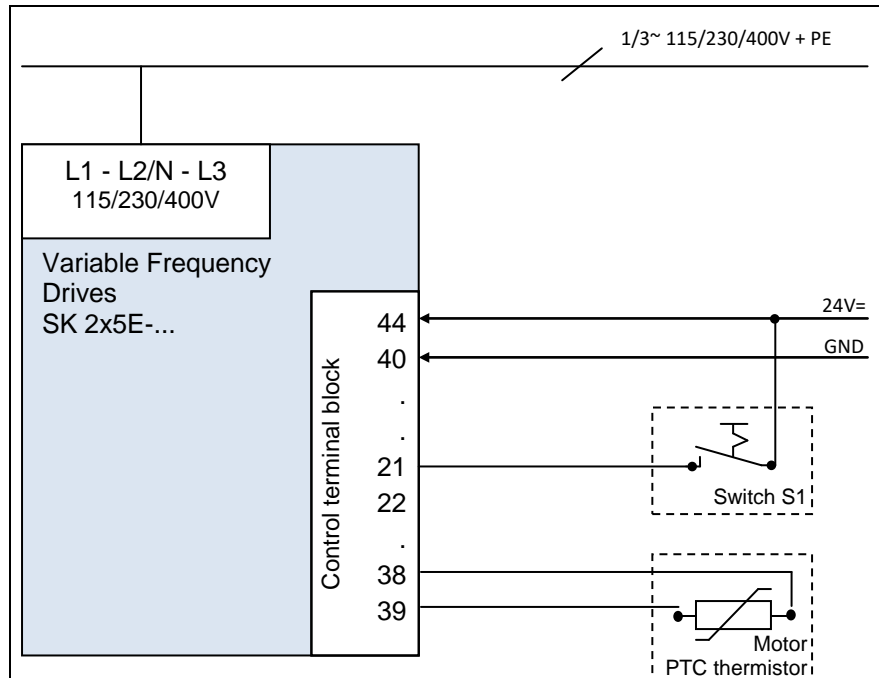

Function	Setting
Setpoint	Integrated potentiometer P1
Frequency ramp	Integrated potentiometer P2
Controller enable	External switch S1

#### Minimum configuration with options

One switch and one potentiometer (such as SK CU4-POT) are required in order to implement completely autonomous operation (independent of control lines, etc.). In combination with an integrated power supply unit (SK CU4-...-24V), a solution that only has the power supply line can be set up with an SK 2x5E, and demand-oriented speed and rotation direction control can be ensured (📖 Section 3.2.4 "Potentiometer adapter, SK CU4-POT").

#### Information

#### Convert analog signal

An 8-bit A/D - converter is integrated in the SK TU4-...-24V and SK CU4-...-24V power supply units. This makes it possible to connect a potentiometer or another analog setpoint source to the power supply unit. The power supply unit can convert the analog setpoint into an appropriate pulse signal. This signal can be connected to a digital input of the variable frequency drive and processed by it as a setpoint.

## Test operation

Variable Frequency Drive versions SK 2x0E in size 4 and SK 2x5E may be operated without any auxiliary equipment for test purposes.

For this purpose, after electrical connection is established, (please see chapter 2.4 "Electrical connection") set DIP switches S1: 1 to 5 of the variable frequency drive to position 0 (OFF) (please see chapter 4.3.2.2 "DIP switches (S1)") and wire digital input DIN1 (terminal 21) permanently to the 24 V control voltage.

Enabling is carried out as soon as the inverter's own setpoint potentiometer (potentiometer P1) is moved from the 0% position.

The setpoint can be adjusted to the requirements by further continuous adjustment of the potentiometer.

Resetting the setpoint to 0% sets the variable frequency drive to "Ready for switch on" status.

Stepwise adjustment of ramp times within defined limits is also possible with the aid of potentiometer P2.

---

## Information

## Test operation

This setting method is not suitable for the implementation of a so-called "automatic AC line starting".

In order to use this function, it is essential that parameter (P428) "Automatic Start" be set to the "ON" function. Adjustment of parameters is possible with the aid of a Parameter Box (SK xxx-3H) or with the NORD CON software (Windows PC and adapter cable required).

---

### 4.4 Temperature sensors

The current vector control of the variable frequency drive can be further optimized by the use of a *temperature sensor*. By continuous measurement of the motor temperature, the highest control accuracy for the variable frequency drive and the associated optimum speed accuracy of the motor are achieved at all times and under any load. Since the temperature measurement starts immediately after the (line power) actuation of the variable frequency drive, the variable frequency drive provides immediate optimum control even if the motor has a considerably elevated temperature after an intermediate "Power Off/Power On" of the variable frequency drive.

#### Information

To determine the stator resistance of the motor, the temperature range 15 ... 25°C should not be exceeded.

Excess temperature of the motor is also monitored and at 155°C (operating point like with the thermistor) causes the drive unit to shut down with error message E002.

#### Information

##### Pay attention to polarity

Temperature sensors are wired semiconductors that must be operated in the conducting direction. In order to do this, the anode must be connected to the "+" contact of the analog input. The cathode must be connected to earth.

Failure to observe this can lead to erroneous measurements. Motor winding protection will no longer be guaranteed.

##### Approved temperature sensors

The function of approved temperature sensors is comparable. However, their characteristic curves differ. Correct matching of the characteristic curves to the variable frequency drive is made by changing the following two parameters.

Sensor type	Shunt resistor [kΩ]	P402[xx] <sup>1)</sup> 0% Adjustment [V]	P403[xx] <sup>1)</sup> 100% Adjustment [V]
KTY84-130	2.7	1.54	2.64
PT100	2.7	0.36	0.49
PT1000	2.7	2.68	3.32

1) | Xx = Parameter array, depending on the analog input used

**Table 12: Temperature sensors, adjustment**

Connection of a temperature sensor is made according to the following examples.

Taking into account the relevant values for the 0% adjustment [P402] and 100% adjustment [P403], these examples can be used for all of the approved temperature sensors which are stated above.

## Connection examples

### SK CU4-IOE / SK TU4-IOE-...

Connection of a KTY-84 to either of the two analog inputs of the relevant option is possible. In the following examples, analog input 2 of the particular optional module is used.

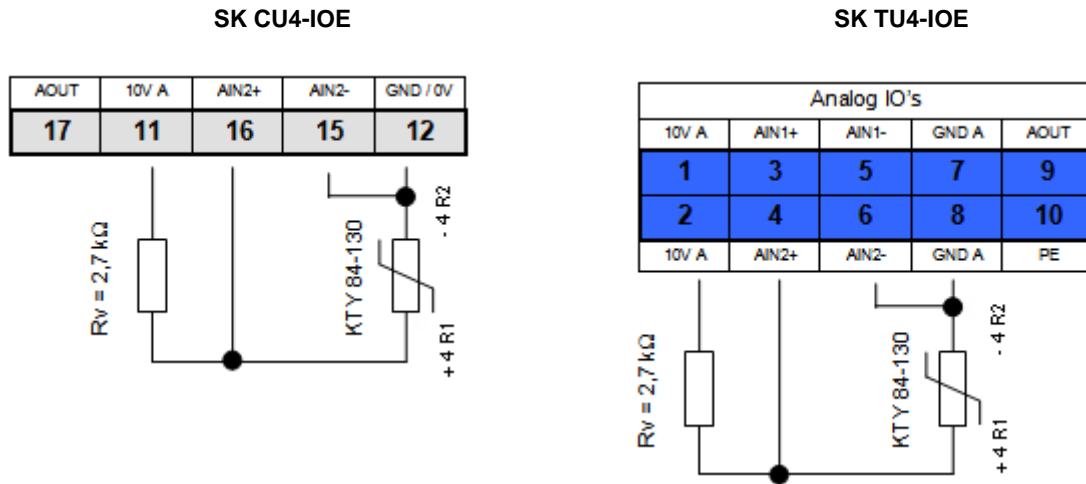

(Illustration shows a section of the terminal blocks)

### Parameter settings (analog input 2)

The following parameters must be set for the function of the KTY84-130.

1. Motor data **P201-P207** must be set according to the nameplate.
2. Motor stator resistance **P208** is determined at 20°C with **P220 = 1**.
3. Analog input 2 function, **P400 [-04] = 30**  
(motor temperature)
4. Analog input 2 mode, **P401 [-02] = 1**  
(negative temperatures are also measured)  
(from firmware version: V1.2)
5. Adjustment of analog input 2: **P402 [-02] = 1.54 V** and **P403 [-02] = 2.64 V**  
(with  $R_v = 2.7 \text{ k}\Omega$ )
6. Adjust time constants: **P161 [-02] = 400 ms** (filter time constant is at a maximum)  
Parameter (P161) is a module parameter. It cannot be set on the variable frequency drive but directly on the I/O- module.  
Communication takes place by directly connecting a Parameter Box to the RS232 interface of the module, for example, or by connecting to the variable frequency drive via the system bus. (Parameter (P1101) object selection → ... )
7. Motor temperature control (display): **P739 [-03]**

### SK 2x0E

A KTY-84 sensor may be connected to either of the two analog inputs of the **SK 2x0E**. In the following examples, analog input 2 of the variable frequency drive is used.

#### SK 2x0E

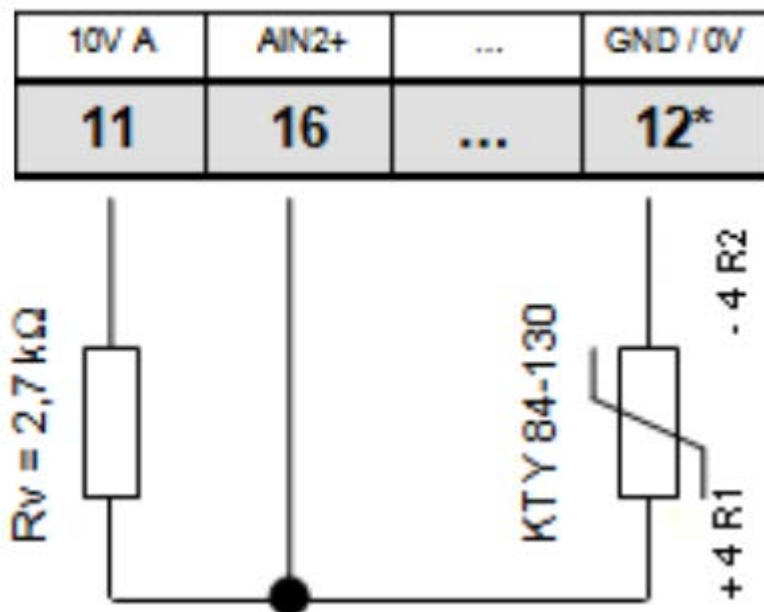

\* If necessary, terminal 40 as well

#### Parameter settings (analog input 2)

The following parameters must be set for the function of the KTY84-130.

1. Motor data **P201-P207** must be set according to the nameplate.
2. Motor stator resistance **P208** is determined at 20°C with **P220 = 1**.
3. Analog input 2 function, **P400 [-02] = 30**  
(motor temperature)
4. Analog input 2 mode, **P401 [-06] = 1**  
(negative temperatures are also measured)
5. Adjustment of analog input 2: **P402 [-06] = 1.54 V** and **P403 [-06] = 2.64 V**  
(with RV= 2.7 kΩ)
6. Adjust time constants: **P404 [-02] = 400 ms** (Filter time constant is maximum)
7. Motor temperature control (display): **P739 [-03]**

### SK 2x5E

Direct connection of a KTY-84 sensor to the **SK 2x5E** is not possible.

In order to use this function on the SK 2x5E, the use of an I/O - extension module (**SK xU4-IOE**) is necessary.

## 4.5 AS interface (AS-i)

This section is only relevant for device of type **SK 22xE / SK 23xE**.

### 4.5.1 The bus system

#### General information

The **actuator-sensor interface** (AS interface) is a bus system for the lower field bus level. It is fully defined in the AS interface *Complete Specification* and standardized as per EN 50295, IEC62026.

The transmission principle is a single master system with cyclical polling. Since *Complete Specification V2.1*, a maximum of **31 standard slaves** which use device profile **S-7.0**, or **62 slaves in an extended addressing mode** that use device profile **S-7.A**, can be operated on a non-shielded two-wire cable up to 100 m in length with any network structure.

The number of possible slave subscribers can be doubled by means of double assignment of addresses 1-31 and designation "A Slave" or "B Slave". Slaves in extended addressing mode are designated by the ID code A and therefore can be uniquely identified by the master.

Devices with slave profiles **S-7.0** and **S-7.A** can be jointly operated within an AS-i network as of version 2.1 (**master profile M4**) with observance of the allocation of addresses (see example).

Permissible	Not permissible
Standard slave 1 (address 6)	Standard slave 1 (address 6)
<b>A/B slave 1 (address 7A)</b>	<b>Standard slave 2 (address 7)</b>
<b>A/B slave 2 (address 7B)</b>	<b>A/B slave 1 (address 7B)</b>
Standard slave 2 (address 8)	Standard slave 3 (address 8)

Addressing is implemented via the master, which can also provide other management functions, or via a separate addressing device.

#### Specific information for the variable frequency drive

The transfer of the 4-bit reference data (in each direction) is performed with effective error protection for standard slaves with a maximum cycle time of 5 ms. Due to the higher number of participants, for slaves in extended addressing mode, the cycle time is doubled (*max. 10 ms*) for data sent *from the slave to the master*. Extended addressing procedures for the transmission of data *to the slave* cause an additional doubling of the cycle time to *max. 21 ms*.

The yellow AS interface cable supplies data and energy.

With special devices **SK 2x5E-...-AUX** and **...-AXB**, the connection of **another two-wire lead (black)** is needed to connect an auxiliary voltage (24 V DC). When doing this it is not strictly necessary to provide the supply via a protective extra-low voltage (**PELV - Protective Extra Low Voltage**) but this is recommended.



### 4.5.2 Features and technical data

The device can be directly integrated in an AS interface network is parameterized in its factory settings so that the most frequently used AS-i functionality is available immediately. Only adaptations for application-specific functions of the device or the bus system, the addressing and proper connection of the supply, BUS, sensor and actuator cables need to be carried out.

#### Features

- Electrically isolated bus interface
- Status display (1 LED) (SK 225E and SK 235E only)
- Configuration optionally via
  - Integrated potentiometer and DIP - switch
  - or by means of parameterization
- 24 V DC supply of integrated AS-i module through yellow AS-i line
- 24 V DC supply of variable frequency drive
  - Via yellow AS-i line (SK 225E and SK 235E only, but not special versions SK 2x5E-...-AUX and -AXB)
  - Via black line or another 24 V DC source – e.g. SK xU4-24V-... power supply unit (special versions SK 2x5E-...-AUX and -AXB only)
- Connection to device
  - via terminal block
  - or via M12 flanged connector

#### Technical data for AS interface

Designation	Value		
	SK 220E / SK 230E SK 225E-...-AXB SK 235E-...-AXB	SK 225E / SK 235E	SK 225E-...-AUX SK 235E-...-AUX
AS-i supply, PWR connection	24 V DC, max. 25 mA	26.5 – 31.6 V DC, max. 290 mA <sup>1)</sup>	24 V DC, max. 25 mA
Slave profile	S-7.A	S-7.0	
I/O code	7	7	
ID code	A	0	
External ID code 1/2	7	F	
Address	1A – 31A and 1B - 31B (delivery condition: 0A)	1 – 31 (delivery condition: 0)	
Cycle time	Slave → master ≤ 10 ms Master → slave ≤ 21 ms	≤ 5 ms	
Quantity of Bus I/O	4I/4O	4I/4O	

1) Of which max. 60 mA for peripherals (initiators, connected parameterization tool, actuators)

### 4.5.3 Bus structure and topology

The AS interface network must be set up in any form (line, star, ring and tree structure) and is managed by an AS-interface master as the interface between the PLC and slaves. Additional slaves can be added to an existing network at any time, up to a limit of 31 standard slaves or 62 slaves in extended addressing mode. The slaves are addressed by the master or an appropriate addressing device.

An AS-i master communicates independently and exchanges data with the connected AS-i slaves. Normal power supply units may not be used in the AS interface network. Only a special AS-interface power unit may be used for the power supply for each AS- interface connector. This AS-interface power supply is connected directly to the yellow standard cable (AS-i(+) and AS-i(-) cable) and should be positioned as close as possible to the AS-i master in order to keep the voltage drop small.

In order to avoid problems, the **PE connection of the AS-interface power supply (if present) must be grounded.**

The brown **AS-i(+)** and the blue **AS-i(-)** wire of the yellow AS interface cable **must not be grounded.**

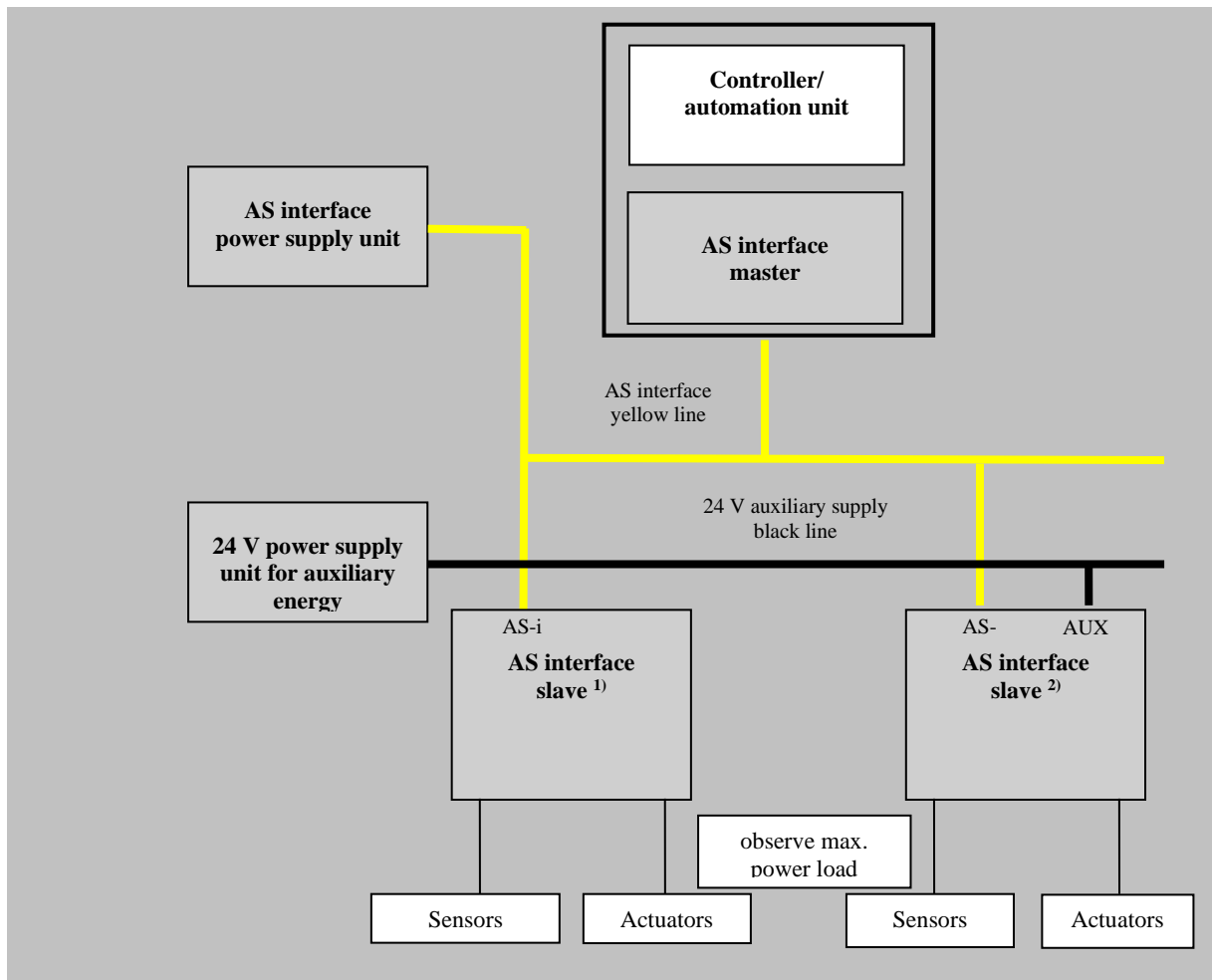

1)	SK 22xE/SK 23xE	
2)	SK 225E-.../SK 235E-...-AUX and -AXB	24 V DC auxiliary energy at terminals 44/40

### 4.5.4 Commissioning

#### 4.5.4.1 Connection

Connection of the AS interface cable (yellow) is made via terminals 85/85 of the terminal block and can optionally be made to an appropriately labeled M12 flange plug connector (yellow).

Details of control terminals (📖 Section 0 "Control terminal details ")

Details of connector (📖 Section 3.2.3 "Plug connector")

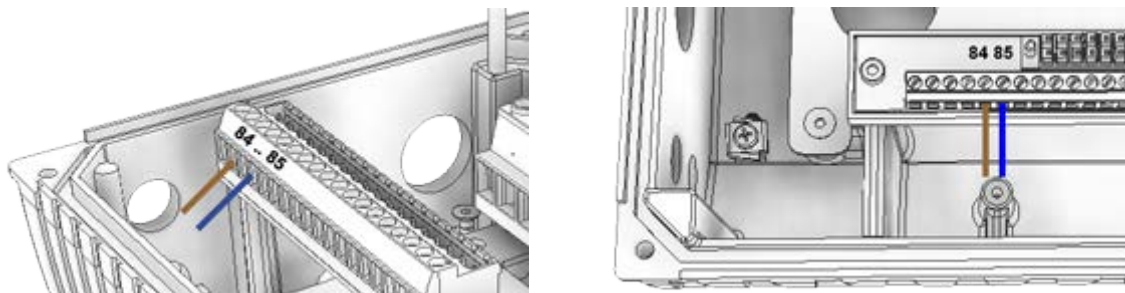

Figure 28: Connecting terminals AS-i, left size 1 – 3, right size 4

Model	Special version	Size	AS- interface connection		Control voltage connection e.g. AUX line of a PELV	
			AS-i(+)	AS-i(-)	24 V DC	GND
SK 220E,		Size 1 – 3	84	85	- 1)	- 1)
SK 230E		BG4	84	85	44 1), 2)	40 1), 2)
SK 225E,		Size 1 – 3	84	85	<b>Connection not permitted!</b>	
SK 235E	- AUX/-AXB	Size 1 – 3	84	85	44	40

1) The control section of the variable frequency drive is not supplied from the AS-i line. The required auxiliary voltage for this is generated by the device itself.

2) Connection possible but not required.

Table 13: AS- interface, connection of signal and supply lines

If the AS- interface ("yellow cable") is not used, the normal connection requirements for the device apply (📖 Section 0 "Control terminal details ").



#### Information

#### 24 V DC / AS-Interface (SK 225E/ SK 235E, except -AUX, -AXB)

With use of the yellow AS interface cable:

- The supply voltage 26.5 - 31.6 V DC) for use of digital inputs or other external peripherals **can be obtained from terminals 44/40**. The permissible total current for this is limited to **60 mA!**  
Terminal "44" of the device is short-circuit proof and is switched off by a thermal safety element in case of overload. The safety device switches on again after a cooling time which depends on the ambient conditions.
- If **no power supply may be connected to terminals 44/40**,
- The frequency inverter is supplied via the AS-i cable.

**Variants of a 24 V supply for the peripherals (e.g. actuators)**

(valid for SK 225E/ SK 235E, except –AUX, –AXB)

**i Information Use of a wall mounting kit with fan**

The following must be noted if the device is operated with a wall mounting kit type **SK TIE4-WMK-L...** (see Section 2.1.3.2 "Wall mounting kit with fan"):

- Supply of the fan via the frequency inverter is not permissible
- Power the fan via a separate 24 V DC power supply: „**Variant 2 – Use of an optional mains unit SK xU4-24V-...**“).

**Variant 1 – connection to 24 V (terminal 44)**

- The limit of 60 mA for the maximum load (total current) must be complied with.

Connection example:

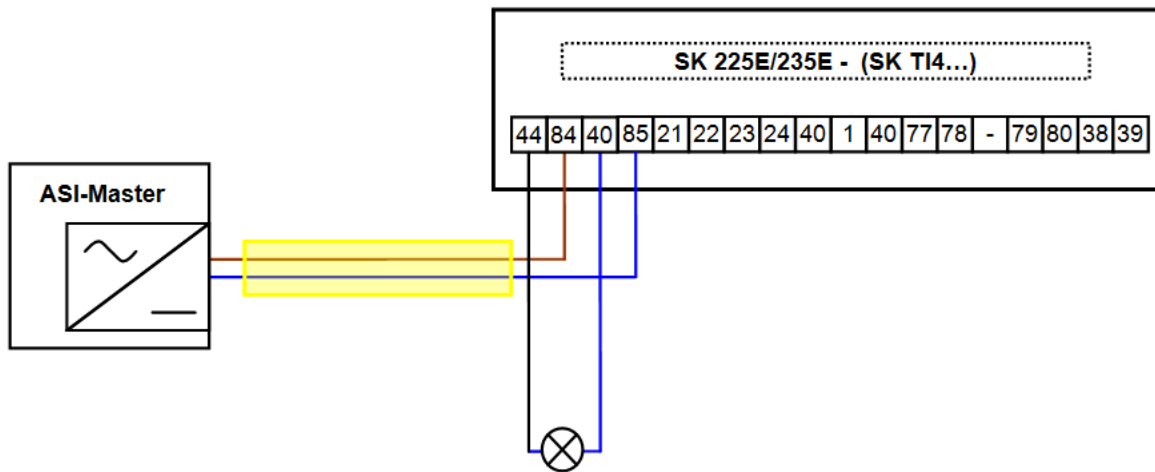

### Variant 2 – use of an optional power supply unit SK xU4-24V-...

Since the permissible load of terminal 44 is limited to 60 mA when using the AS interface, if there is an increased power requirement it is possible to incorporate a power supply unit (e.g. SK CU4-24V-...) to supply power to additional peripherals. **However, under no circumstances must the 24 V voltage of the power supply unit be connected to the variable frequency drive** (see also following connection example).

Connection example:

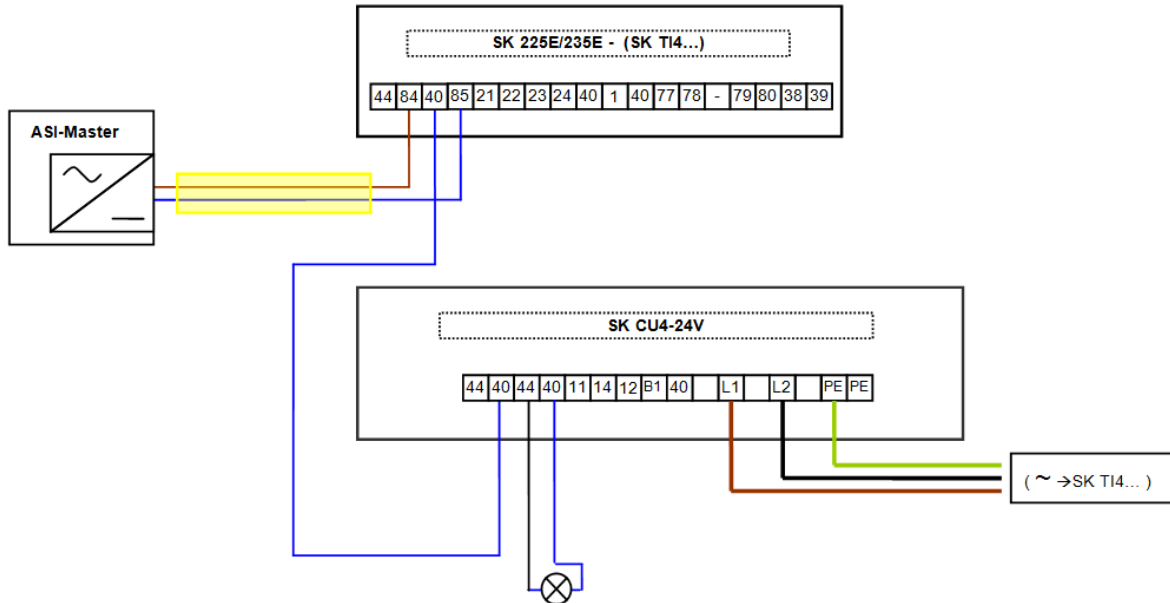

#### 4.5.4.2 Displays

The status of the AS interface is signaled by a multi-color **AS-i** LED.



ASi LED	Meaning
OFF	<ul style="list-style-type: none"> <li>No AS interface voltage to the module</li> <li>Connection cables not connected or incorrectly connected</li> </ul>
green ON	<ul style="list-style-type: none"> <li>Normal operation (AS interface active)</li> </ul>
red ON	<ul style="list-style-type: none"> <li>No exchange of data                             <ul style="list-style-type: none"> <li>Slave address = 0 (slave still in factory setting)</li> <li>Slave not in LPS (list of planned slaves)</li> <li>Slave with incorrect IO/ID</li> <li>Master in STOP mode</li> <li>Reset active</li> </ul> </li> </ul>
red/green Alternating Flashing (2 Hz) <sup>1)</sup>	<ul style="list-style-type: none"> <li>Peripheral error                             <ul style="list-style-type: none"> <li>Control unit in device not starting (AS-i voltage too low or control unit defective)</li> </ul> </li> </ul>

1) Switch-on frequency per second, example: 2 Hz = LED 2 x per second "On"

**The AS-i LED is only available for devices of type SK 2x0E size 4 and SK 2x5E.**

### 4.5.4.3 Configuration

The most important functions (functions of sensor/actuator signals via the AS interface and on-board potentiometers *P1* and *P2* (only SK 2x0E size 4 and SK 2x5E)) can be set on the variable frequency drive via DIP4 and DIP 5 of DIP switch S1 (📖 Section 4.3.2.2 "DIP switches (S1)").

Alternatively, the functions can also be assigned via the arrays [-01] ... [-04] of parameters (P480) and (P481) (📖 Section 5 "Parameter"). Settings that are made in these parameters only become effective if DIP switch S1: (DIP4 and DIP5) are in **position 0 (OFF)**.

The functions of integrated potentiometers P1 and P2 (SK 2x0E size 4 and SK 2x5E only) can be adapted in parameter (P400).

---

#### Information

#### DIP switch

With the DIP switch default settings (S1: DIP4/5 = 0 (off)) the digital inputs of the variable frequency drive are active.

However, as soon as one of the two DIP switches is moved to position I (ON), the digital inputs are deactivated. However, the gateway function of digital inputs 1 and 2 on AS-i out bits 2 and 3 is retained.

---

#### Information

#### Overloading of the 24V supply

*When using the AS-Interface, this affects devices of type SK 2x5E (not special version SK 225E-...-AUX and ...-AXB).*

Because of the low load reserves of the low voltage when using the AS interface, it is advisable to parameterize the variable frequency drive with the aid of NORD CON software. The use of a parameterization unit (SK PAR-3H/SK CSX-3H) can cause damage to the variable frequency drive, particularly during long periods of operation.

---

**Bus I/O bits**



**Unexpected movement due to automatic starting**

In the event of a fault (communication interrupted or bus cable disconnection), the device automatically switches off since the device enable is no longer present.

Restoration of communication may result in an automatic start and hence unexpected movement of the drive unit. To prevent any hazard, a possible automatic start must be prevented as follows:

- If a communication error occurs, the bus master must actively set the control bits to zero.

Initiators can be directly connected to the digital inputs of the variable frequency drive. Actuators can be connected via the available digital outputs of the device. The following connections are each provided for four reference data bits:

BUS-IN	Function (P480[-01...-04])	Status		Status
		Bit 1	Bit 0	
Bit 0	Enable right	0	0	Motor is switched off
Bit 1	Enable left	0	1	Field of rotation right present in motor
Bit 2	Fixed frequency 2 (→ P465[-02])	1	0	Field of rotation left present in motor
Bit 3	Acknowledge fault <sup>1)</sup>	1	1	Motor is switched off

1) Acknowledge with flank 0 → 1.

For control via the bus, acknowledgement is not automatically performed by a flank on one of the enable inputs

BUS-OUT	Function (P481 [-01 ... -04])	Status		Status
		Bit 1	Bit 0	
Bit 0	Inverter ready	0	0	Error active
Bit 1	Warning	0	1	Warning
Bit 2 <sup>1)</sup>	Digital-In 1 status	1	0	Starting disabled
Bit 3 <sup>1)</sup>	Status dig In 2	1	1	Ready for operation

1) Bits 2 and 3 are directly coupled to digital inputs 1 and 2

The configuration of the I/O bits can also take place within a limited scope via DIP-switch S1: 3, 4 and 5 (☞ Section 4.3.2.2 "DIP switches (S1)").

Parallel actuation via the BUS and the digital inputs is possible. The relevant inputs are dealt with more or less as normal digital inputs. If a changeover between manual and automatic is going to take place, it must be ensured that no enable via the normal digital inputs takes place in automatic mode. This could be implemented e.g. with a three-position key switch. Position 1: "Manual left" position 2: "Automatic" position 3 "manual right".

If an enable is present via one of the two "normal" digital inputs, the control bits from the bus system are ignored. An exception is the control bit "Acknowledge fault". This function is always possible in parallel, regardless of the control hierarchy. The bus master can therefore only take over control if no actuation via a digital input takes place. If "Enable left" and "Enable right" are set simultaneously, the enable is removed and the motor stops without a deceleration ramp (block voltage).



### 4.5.4.4 Addressing

In order to use the device in an AS-i network, it must have a unique address. The address is set to 0 in the factory. This means that the device can be recognized as a "new device" by an AS-i master (prerequisite for automatic address assignment by the master).

#### **Procedure**

- Ensure power supply of the AS interface via the yellow AS interface cable.
- Disconnect the AS interface master during addressing
- Set the address  $\neq 0$
- Do not doubly assign addresses

In many other cases, addressing is carried out using a normal addressing device for AS- interface slaves (example follows).

- Pepperl+Fuchs, VBP-HH1-V3.0-V1 (separate M12 connection for external power supply)
- IFM, AC1154 (battery operated addressing device)



### **Information**

### **Special conditions for SK 2x5E**

*Does not apply to special versions ...-AUX and -AXB*

- Also provide voltage supply of variable frequency drive via the yellow AS- interface line (pay attention to power consumption of control level of variable frequency drive (290 mA))
  - When using an addressing device
    - Do not use the internal voltage source of the addressing device
    - Battery-operated addressing devices do not supply the current that is needed and are therefore unsuitable
    - Use addressing unit with a separate 24 V DC connection for an external power supply (example: Pepperl+Fuchs, VBP-HH1-V3.0-V1)
- 

The options for addressing the AS-i slave with an addressing unit in practice are listed below.

**Version 1**

Using an addressing device which is equipped with an **M12- connector** for connecting to the **AS-i** bus, you can connect to the AS-interface network via an appropriate access. The prerequisite for this is that the AS- interface master can be switched off.

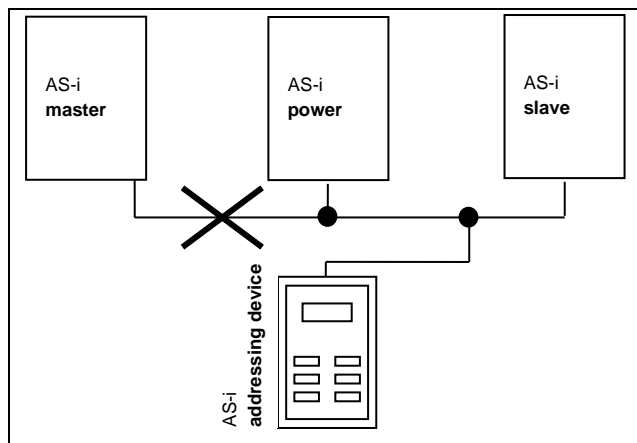

**Version 2**

With an addressing device that is equipped with an **M12- connector** to connect to the **AS-i** bus **and** an additional **M12- connector** to connect an external **voltage supply**, the addressing device can be directly incorporated in the AS-i cable.

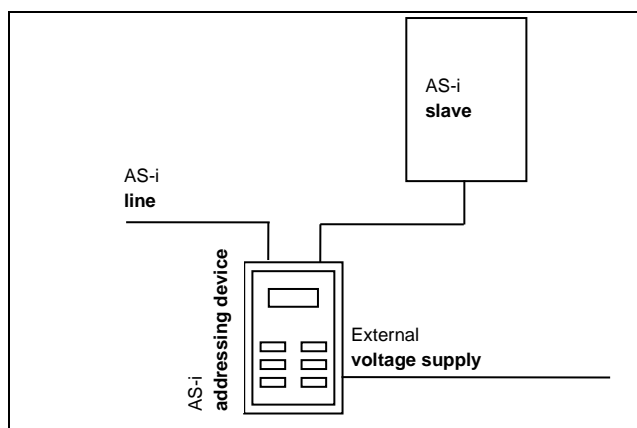

**4.5.5 Certificate**

Currently available certificates can be found on the Internet at [link "www.nord.com"](http://www.nord.com)

## 5 Parameter

### WARNING

#### Unexpected movement

Connection of the supply voltage may directly or indirectly set the device into motion. This may cause unexpected movement of the drive and the attached machine, which may result in serious or fatal injuries and/or material damage. Possible causes of unexpected movements are e.g.:

- Parameterization of an "automatic start"
  - Incorrect parameterization
  - Control of the device with an enabling signal from a higher level control unit (via I/O or bus signals)
  - Incorrect motor data
  - Incorrect encoder connection
  - Release of a mechanical holding brake
  - External influences such as gravity or other kinetic energy which acts on the drive unit
  - In IT systems: System fault (ground fault)
- To avoid any resulting hazard, the drive or drive chain must be secured against unexpected movements (mechanical blocking and/or decoupling, provision of protection against falling, etc.). In addition, make sure that there are no persons within the area of action and the danger area of the system.
- 

### WARNING

#### Unexpected movement due to parameter changes

Parameter changes become effective immediately. Dangerous situations can occur under certain conditions, even when the drive is stationary. Functions such as **P428** "Automatic starting" or **P420** "Digital inputs" or the "Brake off" setting can put the drive in motion and put persons at risk due to moving parts.

Therefore:

- Changes to parameter settings must only be made when the **FEHLER - Variable ohne Inhalt** is not enabled.
  - During parameterization work precautions must be taken to prevent unwanted drive movements (e.g. lifting gear plunging down). The danger area of the system must not be entered.
-

---

** WARNING****Unexpected movement due to overload**

In case of overload of the drive there is a risk that the motor will "break down" (sudden loss of torque). An overload may be caused e.g. by underdimensioning of the drive unit or by the occurrence of sudden peak loads. Sudden peak loads may be of a mechanical origin (e.g. blockage) or may be caused by extremely steep acceleration ramps (P102, P103, P426).

Depending on the type of application, "breakdown" of the motor may cause unexpected movement (e.g. dropping of loads by lifting gear).

To prevent any risk, the following must be observed:

- For lifting gear applications or applications with frequent large load changes, parameter P219 must remain in the factory setting (100%).
  - Do not underdimension the drive unit, provide adequate overload reserves.
  - If necessary, provide fall protection (e.g. for lifting gear) or equivalent protective measures.
-

The relevant parameters for the device are described in the following. The parameters are accessed using a parameterization tool (e.g. NORDCON- software or control and parameterization unit, see also (📖 Section 3.1.1 "Use of control and parameterization units") and therefore makes it possible to adapt the device to the drive task in the best possible way. Different device configurations can result in dependencies for the relevant parameters.

The parameters can only be accessed if the control unit of the device is active.

SK 2x5E type devices must be provided with a 24 V DC control voltage to do this (📖 Section 2.4.3 "Electrical connection of the control unit").

SK 2x0E type devices must be equipped with a power supply that generates the 24 V DC control voltage required for this purpose by applying the line voltage (📖 Section 2.4.2.1 "Power supply connection (L1, L2(/N), L3, PE)").

Limited adaptations of individual functions of the relevant devices can be implemented via DIP - switches. Access to the parameters of the device is essential for all other adaptations. **It should be noted that hardware configurations (DIP - switches) have priority over configuration via software (parameterization).**

Every variable frequency drive is factory-set for a motor of the same power. All parameters can be adjusted online. Four switchable parameter sets are available during operation. The scope of the parameters to be displayed can be changed through supervisor parameter **P003**.

---

### Information

### Incompatibility

In the software change of version **V1.2 R0** of the variable frequency drive, the structure of individual parameters was modified for technical reasons.

(E.g.: Up to version V 1.1 R2 (P417) was a single parameter but from version V1.2 R0 it was subdivided into two arrays ((P417 [-01] and [-02]).

When plugging an EEPROM (memory module) from a variable frequency drive with an earlier software version into a variable frequency drive with software version V1.2 or higher, the stored data is automatically converted to the new format. New parameters are stored with the default setting. This therefore provides correct functionality.

**However, it is not permissible to plug in an EEPROM (memory module) with a software version of V1.2 or above into a variable frequency drive with a previous software version since this would lead to loss of all data.**

---

As delivered, an external EEPROM (memory module) is plugged into the variable frequency drive.

#### ***The following applies up to firmware version V1.4 R1:***

All parameter changes are made in the plug-in (external) EEPROM. As of firmware version 1.3, an internal EEPROM is automatically activated for data management if the plug-in EEPROM is removed. Parameter changes therefore affect the internal EEPROM.

The variable frequency drive treats the external EEPROM with a higher priority. This means that as soon as an external EEPROM (memory module) is plugged in, the dataset of the internal EEPROM is concealed.

The datasets can be copied between the internal and the external EEPROM (P550).

**The following applies as of firmware version V1.4 R2:**

All parameter changes are made in the internal EEPROM. If an external EEPROM has been connected, all changes are automatically stored on this as well. The external EEPROM therefore acts as an additional data backup. Parameter P550 can be used to transfer data from the external EEPROM to the internal EEPROM (e.g. during the data transfer between different devices of the same type). It is also possible to trigger the copying procedure using DIP switches (📖 Section 4.3.2.2 "DIP switches (S1)").

The relevant parameters for the device are described below. Please refer to the respective supplementary manuals for explanations for parameters which concern the field bus options or the special functionality of the POSICON, for example.

The individual parameters are combined in functional groups. The first digit of the parameter number indicates the assignment to a **menu group**:

Menu group	No.	Master function
Status displays	(P0--)	Display of parameters and operating values
Basic parameters	(P1--)	Basic device settings, e.g. behavior when switching on and off
Motor data	(P2--)	Electrical settings for the motor (motor current or starting voltage)
Speed control	(P3--)	Setting of current and speed controllers and settings for rotary encoders (incremental encoders) and settings for the integrated PLC
Control terminals	(P4--)	Assignment of functions for the inputs and outputs
Additional parameters	(P5--)	Mainly monitoring functions and other parameters
Positioning	(P6--)	Setting of the positioning function (details 📖 <a href="#">BU0210</a> )
Information	(P7--)	Display of operating values and status messages

## Information

### Factory setting P523

The factory settings of the entire parameter set can be loaded at any time using parameter **P523**. For example, this can be useful during commissioning if it is not known which device parameters have been changed earlier and could have an unexpected influence on the operating behavior of the drive.

The restoration of the factory settings (**P523**) normally affects all parameters. This means that all motor data must subsequently be checked or reconfigured. However, parameter **P523** also provides a facility for excluding the motor data or the parameters relating to bus communication when the factory settings are restored.

It is advisable to back up the present settings of the variable frequency drive beforehand.

## 5.1 Parameter overview

### Operating displays

<b>P000</b> Operating display	<b>P001</b> Display selection	<b>P002</b> Display factor
<b>P003</b> Supervisor code		

### Basic parameters

<b>P100</b> Parameter set	<b>P101</b> Copy parameter set	<b>P102</b> Acceleration time
<b>P103</b> Deceleration time	<b>P104</b> Minimum frequency	<b>P105</b> Maximum frequency
<b>P106</b> Ramp smoothing	<b>P107</b> Brake reaction time	<b>P108</b> Disconnection mode
<b>P109</b> DC brake current	<b>P110</b> Time DC brake on	<b>P111</b> P factor torque limit
<b>P112</b> Torque current limit	<b>P113</b> Jog frequency	<b>P114</b> Brake delay off
<b>P120</b> Ext control units		

### Motor data

<b>P200</b> Motor list	<b>P201</b> Nominal frequency	<b>P202</b> Nominal speed
<b>P203</b> Nominal current	<b>P204</b> Nominal voltage	<b>P205</b> Nominal power
<b>P206</b> Cos phi	<b>P207</b> Star Delta con.	<b>P208</b> Stator resistance
<b>P209</b> No load current	<b>P210</b> Static boost	<b>P211</b> Dynamic boost
<b>P212</b> Slip compensation	<b>P213</b> ISD ctrl. loop gain	<b>P214</b> Torque precontrol
<b>P215</b> Boost precontrol	<b>P216</b> Time boost prectrl.	<b>P217</b> Oscillation damping
<b>P218</b> Modulation depth	<b>P219</b> Auto.magn.adjustment	<b>P220</b> Par. identification
<b>P240</b> EMF voltage PMSM	<b>P241</b> Inductivity PMSM	<b>P243</b> Reluct. angle IPMSM
<b>P244</b> Peak current PMSM	<b>P245</b> Osc damping PMSM VFC	<b>P246</b> Mass inertia PMSM
<b>P247</b> Switch freq VFC PMSM		

### Speed control

<b>P300</b> Servo mode	<b>P301</b> Incremental encoder	<b>P310</b> Speed Ctrl P
<b>P311</b> Speed Ctrl I	<b>P312</b> Torque curr. ctrl. P	<b>P313</b> Torque curr. ctrl. I
<b>P314</b> Torq. curr. ctrl limit	<b>P315</b> Field curr. ctrl. P	<b>P316</b> Field curr. ctrl. I
<b>P317</b> Field curr. ctrl lim.	<b>P318</b> P-weak	<b>P319</b> I-weak
<b>P320</b> Weak border	<b>P321</b> Speed ctr.I brake off	<b>P325</b> Function encoder
<b>P326</b> Ratio encoder	<b>P327</b> Speed slip error	<b>P328</b> Speed slip delay
<b>P330</b> Ident. startrotor pos.	<b>P331</b> Switch over freq.	<b>P332</b> Hyst. switchover freq.
<b>P333</b> Flux feedb. fact. PMSM	<b>P334</b> Encoder offset PMSM	<b>P336</b> Mode rotor pos. ident.
<b>P350</b> PLC functionality	<b>P351</b> PLC set val. select.	<b>P353</b> Bus status via PLC
<b>P355</b> PLC integer setvalue	<b>P356</b> PLC long setvalue	<b>P360</b> PLC display value
<b>P370</b> PLC status		

**Control terminals**

<b>P400</b> Function Setpoint inputs	<b>P401</b> Analog input mode	<b>P402</b> Adjustment: 0%
<b>P403</b> Adjustment: 100%	<b>P404</b> Analog input filter	<b>P410</b> Min. freq. Auxiliary setpoint
<b>P411</b> Max. freq. Auxiliary setpoint	<b>P412</b> Process controller setpoint	<b>P413</b> PI controller P comp.
<b>P414</b> PI controller I comp.	<b>P415</b> Process controller limit	<b>P416</b> Ramp time PI setpoint
<b>P417</b> Analog output offset	<b>P418</b> Function Analog output	<b>P419</b> Standard Analog output
<b>P420</b> Digital inputs	<b>P426</b> Quick stop time	<b>P427</b> Emerg. stop Fault
<b>P428</b> Automatic start	<b>P434</b> Digital output function	<b>P435</b> Dig. out scaling
<b>P436</b> Dig. out. hysteresis	<b>P460</b> Watchdog time	<b>P464</b> Fixed frequency mode
<b>P465</b> Fixed freq. field	<b>P466</b> Minimum freq. process controller	<b>P475</b> Delay on/off switch
<b>P480</b> Function BusIO In bits	<b>P481</b> Function BusIO Out bits	<b>P482</b> Standard BusIO Out bits
<b>P483</b> Hyst. BusIO Out bits		

**Additional parameters**

<b>P501</b> Inverter name	<b>P502</b> Master function value	<b>P503</b> Master function output
<b>P504</b> Pulse frequency	<b>P505</b> Absolute minimum freq.	<b>P506</b> Auto. Fault acknowledgement
<b>P509</b> Source control word	<b>P510</b> Source setpoints	<b>P511</b> USS baud rate
<b>P512</b> USS address	<b>P513</b> Telegram timeout	<b>P514</b> CAN bus baud rate
<b>P515</b> CAN address	<b>P516</b> Skip frequency 1	<b>P517</b> Skip freq. area 1
<b>P518</b> Skip frequency 2	<b>P519</b> Skip freq. area 2	<b>P520</b> Flying restart circuit
<b>P521</b> Flying restart circuit Resolution	<b>P522</b> Flying restart circuit Offset	<b>P523</b> Factory setting
<b>P525</b> Load control max	<b>P526</b> Load control min	<b>P527</b> Load monitoring Freq.
<b>P528</b> Load monitoring delay	<b>P529</b> Load control mode	<b>P533</b> I <sup>2</sup> t factor
<b>P534</b> Torque shutoff limit	<b>P535</b> I <sup>2</sup> t motor	<b>P536</b> Current limit
<b>P537</b> Pulse disconnection	<b>P539</b> Output monitoring	<b>P540</b> Rotation direction mode
<b>P541</b> Set relays	<b>P542</b> Set analog output	<b>P543</b> Bus actual value
<b>P546</b> Function bus setpoint	<b>P549</b> Pot box function	<b>P550</b> EEPROM Copy Order
<b>P552</b> CAN master cycle	<b>P553</b> PLC setpoint	<b>P555</b> P limit chopper
<b>P556</b> Braking resistor	<b>P557</b> Braking resistor capacity	<b>P558</b> Magnetizing time
<b>P559</b> DC run-on time	<b>P560</b> Parameter saving mode	

**Positioning**

<b>P600</b> Position control	<b>P601</b> Actual position	<b>P602</b> Actual setpoint position
<b>P603</b> Actual pos. diff.	<b>P604</b> Distance measuring system	<b>P605</b> Absolute encoder
<b>P607</b> Transformation ratio	<b>P608</b> Reduction ratio	<b>P609</b> Offset position
<b>P610</b> Setpoint mode	<b>P611</b> Position controller P	<b>P612</b> Target window limit
<b>P613</b> Position	<b>P615</b> Maximum position	<b>P616</b> Minimum position
<b>P625</b> Output hysteresis	<b>P626</b> Comparative position Output	<b>P630</b> Position slip error
<b>P631</b> Slip error Abs./inc.	<b>P640</b> Unit of pos. value	



### Information

<b>P700</b> Current operating state	<b>P701</b> Last fault	<b>P702</b> Freq. last error
<b>P703</b> Current last error	<b>P704</b> Volt. last error	<b>P705</b> DC link volt. last er.
<b>P706</b> P set last error	<b>P707</b> Software version	<b>P708</b> State of digital in.
<b>P709</b> Analog input voltage	<b>P710</b> Analog output voltage	<b>P711</b> State of relays
<b>P714</b> Operating time	<b>P715</b> Running time	<b>P716</b> Current frequency
<b>P717</b> Current speed	<b>P718</b> Current set freq.	<b>P719</b> Actual current
<b>P720</b> Act. torque current	<b>P721</b> Actual field current	<b>P722</b> Current voltage
<b>P723</b> Voltage -d	<b>P724</b> Voltage -q	<b>P725</b> Current cos phi
<b>P726</b> Apparent power	<b>P727</b> Mechanical power	<b>P728</b> Input voltage
<b>P729</b> Torque	<b>P730</b> Field	<b>P731</b> Parameter set
<b>P732</b> Phase U current	<b>P733</b> Phase V current	<b>P734</b> Phase W current
<b>P735</b> Speed encoder	<b>P736</b> DC link voltage	<b>P737</b> Usage rate brake res.
<b>P738</b> Usage rate motor	<b>P739</b> Heat sink temperature	<b>P740</b> PZD bus in
<b>P741</b> PZD bus out	<b>P742</b> Database version	<b>P743</b> Inverter ID
<b>P744</b> Configuration		
<b>P747</b> Inverter volt. range	<b>P748</b> Status CANopen	<b>P749</b> Status DIP switches
<b>P750</b> Stat. overcurrent	<b>P751</b> Stat. overvoltage	<b>P752</b> Stat. mains failure
<b>P753</b> Stat. overtemperature	<b>P754</b> Stat. parameter loss	<b>P755</b> Stat. system error
<b>P756</b> Stat. timeout	<b>P757</b> Stat. customer error	<b>P760</b> Input current
<b>P780</b> Device ID	<b>P799</b> Op. time last error	

## 5.2 Description of parameters

Pxxx <b>1</b>	[-01] xxxxx <b>2</b>	xxxxx (XXXXXXXXXX) <b>3</b>	SK. <b>4</b>	<b>5</b> S	<b>6</b> P
0 ... 36 { 1 } <b>7</b>	[-01] = x.xxx, xxxxxxxx	<b>8</b>			
<b>9</b>	[-02] = x.xxx, xxxxxxxx				

- 1 Parameter number
- 2 Array values
- 3 Parameter text; top: Display in Parameter Box, bottom: Meaning
- 4 Special features (e.g. only available in device model SK xxx)
- 5 (S) Supervisor type parameter, → depending on setting in **P003**
- 6 (P) Parameter to which different values can be assigned depending on the selected parameter set (selection in **P100**)
- 7 Parameter value range
- 8 Description of parameters
- 9 Factory settings (default value) of parameter

### Array parameter display

Some parameters have the option of displaying settings and views in several levels ("arrays"). After the parameter is selected, the array level is displayed and must then also be selected.

If Simple Box SK CSX-3H is used, the array level is shown by **\_ - 0 1**. With Parameter Box SK PAR-3H (picture on right) the selection options for the array level appear at the top right of the display (example: **[01]**).

### Array display:

#### Simple Box SK CSX-3H

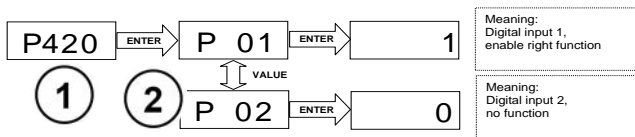

- 1 Parameter number
- 2 Array

#### Parameter Box SK PAR-3H



- 1 Parameter number
- 2 Array

### 5.2.1 Operating display

Abbreviations used

- **VFD** = variable frequency drive
- **SW** = software version, stored in P707.
- **S** = **supervisor parameters**, these are visible or hidden depending on P003.

Parameter {factory setting}	Setting value/description/note		Supervisor	Parameter set																																																																																	
<b>P000</b>	<b>Operating display</b> ( <i>operating display</i> )																																																																																				
0.01 ... 9999	The operating value selected in parameter P001 is shown <i>online</i> in parameterization units with 7-segment display (e.g. Simple Box). Important information about the operating mode of the drive can be read out as required.																																																																																				
<b>P001</b>	<b>Display selection</b> ( <i>display selection</i> )																																																																																				
0 ... 65 { 0 }	Selection of status display of a parameterization unit with 7-segment display (e.g.: Simple Box)																																																																																				
	<table border="0"> <tr> <td>0 =</td> <td><b>Actual frequency [Hz]</b></td> <td>Currently supplied output frequency</td> </tr> <tr> <td>1 =</td> <td><b>Speed [rpm]</b></td> <td>Calculated speed</td> </tr> <tr> <td>2 =</td> <td><b>Target frequency [Hz]</b></td> <td>Output frequency that corresponds to the available setpoint. This need not correspond with the current output frequency.</td> </tr> <tr> <td>3 =</td> <td><b>Current [A]</b></td> <td>Prevailing measured output current</td> </tr> <tr> <td>4 =</td> <td><b>Torque current [A]:</b></td> <td>torque-generating output current</td> </tr> <tr> <td>5 =</td> <td><b>Voltage [V AC]</b></td> <td>Prevailing alternating voltage present on the device output</td> </tr> <tr> <td>6 =</td> <td><b>DC link voltage [V DC]</b></td> <td>The <i>DC link voltage</i> is the internal DC voltage of the VFD. This depends on the magnitude of the line voltage among other things.</td> </tr> <tr> <td>7 =</td> <td><b>cos phi</b></td> <td>Currently calculated value of the power factor</td> </tr> <tr> <td>8 =</td> <td><b>Apparent power [kVA]</b></td> <td>Calculated prevailing apparent power</td> </tr> <tr> <td>9 =</td> <td><b>Real power [kW]</b></td> <td>Calculated prevailing effective power</td> </tr> <tr> <td>10 =</td> <td><b>Torque [%]</b></td> <td>Calculated prevailing torque</td> </tr> <tr> <td>11 =</td> <td><b>Field [%]</b></td> <td>Calculated prevailing field in motor</td> </tr> <tr> <td>12 =</td> <td><b>On-time [h]</b></td> <td>Time for which line voltage present on device</td> </tr> <tr> <td>13 =</td> <td><b>Run-time [h]</b></td> <td>"<i>Enable operating hours</i>" is the time for which the device was enabled.</td> </tr> <tr> <td>14 =</td> <td><b>Analog input 1 [%]</b></td> <td>Current value that is present at analog input 1 of the device</td> </tr> <tr> <td>15 =</td> <td><b>Analog input 2 [%]</b></td> <td>Current value that is present at analog input 2 of the device</td> </tr> <tr> <td>16 =</td> <td><b>... 18</b></td> <td><i>Reserved, POSICON</i></td> </tr> <tr> <td>19 =</td> <td><b>temp. of heat sink [°C]</b></td> <td>Current temperature of the heat sink</td> </tr> <tr> <td>20 =</td> <td><b>usage rate motor [%]</b></td> <td>Average motor load based on known motor data (P201...P209).</td> </tr> <tr> <td>21 =</td> <td><b>usage rate brakeres. [%]</b></td> <td>"<i>usage rate brakeres.</i>" is the average braking resistor load based on known resistor data (P556...P557).</td> </tr> <tr> <td>22 =</td> <td><b>Inside inverter temp [°C]</b></td> <td>Current interior temperature of device (<i>SK 54xE/SK 2xxE</i>)</td> </tr> <tr> <td>23 =</td> <td><b>Motor temperature</b></td> <td>Measured via KTY-84</td> </tr> <tr> <td>24 =</td> <td><b>... 29</b></td> <td><i>Reserved</i></td> </tr> <tr> <td>30 =</td> <td><b>cur. set value MP-S [Hz]</b></td> <td>"<i>Prevailing motor potentiometer function with storage setpoint</i>". (P420...=71/72). Through this function the setpoint can be read out or pre-set (without the drive running).</td> </tr> <tr> <td>31 =</td> <td><b>... 39</b></td> <td><i>Reserved</i></td> </tr> <tr> <td>40 =</td> <td><b>PLC control box value</b></td> <td>Visualization mode for PLC communication</td> </tr> <tr> <td>41 =</td> <td><b>... 59</b></td> <td><i>Reserved, POSICON</i></td> </tr> </table>	0 =	<b>Actual frequency [Hz]</b>	Currently supplied output frequency	1 =	<b>Speed [rpm]</b>	Calculated speed	2 =	<b>Target frequency [Hz]</b>	Output frequency that corresponds to the available setpoint. This need not correspond with the current output frequency.	3 =	<b>Current [A]</b>	Prevailing measured output current	4 =	<b>Torque current [A]:</b>	torque-generating output current	5 =	<b>Voltage [V AC]</b>	Prevailing alternating voltage present on the device output	6 =	<b>DC link voltage [V DC]</b>	The <i>DC link voltage</i> is the internal DC voltage of the VFD. This depends on the magnitude of the line voltage among other things.	7 =	<b>cos phi</b>	Currently calculated value of the power factor	8 =	<b>Apparent power [kVA]</b>	Calculated prevailing apparent power	9 =	<b>Real power [kW]</b>	Calculated prevailing effective power	10 =	<b>Torque [%]</b>	Calculated prevailing torque	11 =	<b>Field [%]</b>	Calculated prevailing field in motor	12 =	<b>On-time [h]</b>	Time for which line voltage present on device	13 =	<b>Run-time [h]</b>	" <i>Enable operating hours</i> " is the time for which the device was enabled.	14 =	<b>Analog input 1 [%]</b>	Current value that is present at analog input 1 of the device	15 =	<b>Analog input 2 [%]</b>	Current value that is present at analog input 2 of the device	16 =	<b>... 18</b>	<i>Reserved, POSICON</i>	19 =	<b>temp. of heat sink [°C]</b>	Current temperature of the heat sink	20 =	<b>usage rate motor [%]</b>	Average motor load based on known motor data (P201...P209).	21 =	<b>usage rate brakeres. [%]</b>	" <i>usage rate brakeres.</i> " is the average braking resistor load based on known resistor data (P556...P557).	22 =	<b>Inside inverter temp [°C]</b>	Current interior temperature of device ( <i>SK 54xE/SK 2xxE</i> )	23 =	<b>Motor temperature</b>	Measured via KTY-84	24 =	<b>... 29</b>	<i>Reserved</i>	30 =	<b>cur. set value MP-S [Hz]</b>	" <i>Prevailing motor potentiometer function with storage setpoint</i> ". (P420...=71/72). Through this function the setpoint can be read out or pre-set (without the drive running).	31 =	<b>... 39</b>	<i>Reserved</i>	40 =	<b>PLC control box value</b>	Visualization mode for PLC communication	41 =	<b>... 59</b>	<i>Reserved, POSICON</i>			
0 =	<b>Actual frequency [Hz]</b>	Currently supplied output frequency																																																																																			
1 =	<b>Speed [rpm]</b>	Calculated speed																																																																																			
2 =	<b>Target frequency [Hz]</b>	Output frequency that corresponds to the available setpoint. This need not correspond with the current output frequency.																																																																																			
3 =	<b>Current [A]</b>	Prevailing measured output current																																																																																			
4 =	<b>Torque current [A]:</b>	torque-generating output current																																																																																			
5 =	<b>Voltage [V AC]</b>	Prevailing alternating voltage present on the device output																																																																																			
6 =	<b>DC link voltage [V DC]</b>	The <i>DC link voltage</i> is the internal DC voltage of the VFD. This depends on the magnitude of the line voltage among other things.																																																																																			
7 =	<b>cos phi</b>	Currently calculated value of the power factor																																																																																			
8 =	<b>Apparent power [kVA]</b>	Calculated prevailing apparent power																																																																																			
9 =	<b>Real power [kW]</b>	Calculated prevailing effective power																																																																																			
10 =	<b>Torque [%]</b>	Calculated prevailing torque																																																																																			
11 =	<b>Field [%]</b>	Calculated prevailing field in motor																																																																																			
12 =	<b>On-time [h]</b>	Time for which line voltage present on device																																																																																			
13 =	<b>Run-time [h]</b>	" <i>Enable operating hours</i> " is the time for which the device was enabled.																																																																																			
14 =	<b>Analog input 1 [%]</b>	Current value that is present at analog input 1 of the device																																																																																			
15 =	<b>Analog input 2 [%]</b>	Current value that is present at analog input 2 of the device																																																																																			
16 =	<b>... 18</b>	<i>Reserved, POSICON</i>																																																																																			
19 =	<b>temp. of heat sink [°C]</b>	Current temperature of the heat sink																																																																																			
20 =	<b>usage rate motor [%]</b>	Average motor load based on known motor data (P201...P209).																																																																																			
21 =	<b>usage rate brakeres. [%]</b>	" <i>usage rate brakeres.</i> " is the average braking resistor load based on known resistor data (P556...P557).																																																																																			
22 =	<b>Inside inverter temp [°C]</b>	Current interior temperature of device ( <i>SK 54xE/SK 2xxE</i> )																																																																																			
23 =	<b>Motor temperature</b>	Measured via KTY-84																																																																																			
24 =	<b>... 29</b>	<i>Reserved</i>																																																																																			
30 =	<b>cur. set value MP-S [Hz]</b>	" <i>Prevailing motor potentiometer function with storage setpoint</i> ". (P420...=71/72). Through this function the setpoint can be read out or pre-set (without the drive running).																																																																																			
31 =	<b>... 39</b>	<i>Reserved</i>																																																																																			
40 =	<b>PLC control box value</b>	Visualization mode for PLC communication																																																																																			
41 =	<b>... 59</b>	<i>Reserved, POSICON</i>																																																																																			

60 =	<b>Stator R ID</b>	Stator resistance determined by means of measurement (P220)
61 =	<b>Rotor R ID</b>	Rotor resistance determined by measurement ((P220) function 2)
62 =	<b>Stator stray L ID</b>	Leakage inductance determined by measurement ((P220) function 2)
63 =	<b>Stator L ID</b>	Inductance determined by measurement ((P220) function 2)
65 =		<i>Reserved</i>

<b>P002</b>	<b>Display factor</b> <i>(display factor)</i>		<b>S</b>	
-------------	--	--	----------	--

0.01 ... 999.99  
{ 1.00 }

The operating value selected in parameter P001 >Selection of operating value display< is multiplied with the scaling factor and displayed in P000 >Status display<.  
It is therefore possible to display system-specific operating values such as the flow rate.

<b>P003</b>	<b>Supervisor code</b> <i>(supervisor code)</i>			
-------------	--	--	--	--

0 ... 9999  
{ 1 }

**0** = The supervisor parameters and groups P3xx/P6xx are not visible, otherwise all.  
**1** = All parameters are visible, except groups P3xx and P6xx.  
**2** = All parameters are visible, except group P6xx.  
**3** = All parameters are visible.  
**4** = ... 9999, only parameters P001 and P003 are visible.



**Information**

**Display via NORDCON**

If parameterization is carried out with the NORDCON software, settings 4 ... 9999 behave like setting 0. Settings 1 and 2 behave like setting 3.

### 5.2.2 Basic parameter

Parameter {factory setting}	Setting value/description/note		Supervisor	Parameter set
<b>P100</b>	<b>Parameter set</b> <i>(parameter set)</i>		<b>S</b>	
0 ... 3 { 0 }	<p>Selection of parameters set to be parameterized. There are 4 parameter sets available. The parameters to which different values can also be assigned in the 4 parameter sets are known as "parameter set-dependent" and are marked with a "P" in the header in the following descriptions. The operating parameter set is selected via appropriately parameterized digital inputs or BUS actuation.</p> <p>When enabled via the keyboard (Simple Box, Control Unit, Potentiometer Unit or Parameter Unit), the operating parameter set will match the setting in P100.</p>			
<b>P101</b>	<b>Copy parameter set</b> <i>(copy parameter set)</i>		<b>S</b>	
0 ... 4 { 0 }	<p>After confirmation with the OK/ENTER key, the parameter set selected in P100 &gt;Parameter set&lt; is copied to the parameter set dependent on the value selected here</p> <p><b>0 = do not copy</b></p> <p><b>1 = copy to param. set 1:</b> copies the active parameter set to parameter set 1</p> <p><b>2 = copy actual to P2:</b> copies the active parameter set to parameter set 2</p> <p><b>3 = copy actual to P3:</b> copies the active parameter set to parameter set 3</p> <p><b>4 = copy actual to P4:</b> copies the active parameter set to parameter set 4</p>			
<b>P102</b>	<b>Acceleration time</b> <i>(ramp-up time)</i>			<b>P</b>
0 ... 320.00 s { 2.00 }	<p>Ramp-up time is the time corresponding to the linear frequency rise from 0 Hz to the set maximum frequency (P105). If a prevailing setpoint of &lt;100% is used, the ramp-up time is reduced linearly according to the setpoint fixed.</p> <p>Ramp-up time can be extended by certain circumstances such as VFD overload, setpoint delay, rounding off, or if the current limit is reached.</p> <p><b>NOTE:</b></p> <p>Make sure parameter values are realistic. A setting of P102 = 0 is not permissible for drive units!</p> <p><b>Notes on ramp gradient:</b></p> <p>Ramp gradient is governed by rotor inertia among other things. A ramp with a gradient that is too steep may result in motor stalling.</p> <p>In general, avoid extremely steep ramps (e.g.: 0 Hz - 50 Hz in &lt; 0.1 s) as this may cause damage to the variable frequency drive.</p>			

<b>P103</b>	<b>Deceleration time</b> <i>(deceleration time)</i>			<b>P</b>
<p>0 ... 320.00 s { 2.00 }</p>	<p>Deceleration time the time corresponding to the linear frequency reduction from the set maximum frequency to 0 Hz (P105). If a prevailing setpoint of &lt;100% is used, the deceleration time decreases accordingly.</p> <p>Deceleration time can be extended by certain circumstances such as the selected &gt;Switch-off mode&lt; (P108) or &gt;Ramp rounding-off&lt; (P106).</p> <p><b>NOTE:</b> Make sure parameter values are realistic. A setting of P103 = 0 is not permissible for drive units!</p> <p><b>Notes on ramp gradient:</b> see parameter (P102)</p>			
<b>P104</b>	<b>Minimum frequency</b> <i>(minimum frequency)</i>			<b>P</b>
<p>0.0 ... 400.0 Hz { 0.0 }</p>	<p>The minimum frequency is the frequency supplied by the VFD as soon as it is enabled and no additional setpoint is set.</p> <p>These are added to the set minimum frequency in combination with other setpoints (e.g. analog setpoint or fixed frequencies).</p> <p>This frequency is not reached when</p> <ol style="list-style-type: none"> <li>the drive is accelerated from standstill.</li> <li>the VFD is blocked. The frequency then decreases to the absolute minimum frequency (P505) before it is blocked.</li> <li>the VFD reverses. The rotating field reverses at the absolute minimum frequency (P505).</li> </ol> <p>This frequency can be continuously not reached if the "Maintain Frequency" function (digital input function = 9) is executed during acceleration or braking.</p>			
<b>P105</b>	<b>Maximum frequency</b> <i>(maximum frequency)</i>			<b>P</b>
<p>0.1 ... 400.0 Hz { 50.0 }</p> <p>{ 50.0 } DIP7 = off { 60.0 } DIP7 = on (chapter 4.3.2.2)</p>	<p>The frequency supplied by the VFD after being enabled and once the maximum setpoint is present, e.g. analog setpoint corresponding to P403, an appropriate fixed frequency or maximum via the Simple Box/Parameter Box.</p> <p>This frequency can only be exceeded through slip compensation (P212), the "Maintain the freq." function (digital input function = 9) or switching to another parameter set with a lower maximum frequency.</p> <p>Maximum frequencies are subject to certain restrictions, e.g.</p> <ul style="list-style-type: none"> <li>restrictions in the field weakening mode,</li> <li>compliance with mechanically permissible speeds,</li> <li>PMSM: maximum frequency restricted to a value that is slightly above the rated frequency.</li> </ul> <p>This value is calculated from the motor data and the input voltage.</p>			

<p><b>P106</b></p>	<p><b>Ramp smoothing</b> (ramp rounding-off)</p>			<p><b>P</b></p>
--------------------	--	--	--	-----------------

0 ... 100 %  
{ 0 }

This parameter rounds off the acceleration and deceleration ramp. This is necessary for applications where gentle but dynamic speed change is important.

Rounding off is carried out for every setpoint change.

The value to be set is based on the set acceleration and deceleration time, however values <10% have no effect.

The following then applies to the entire acceleration or deceleration time, including rounding off:

$$t_{\text{tot ACCELERATION TIME}} = t_{P102} + t_{P102} \cdot \frac{P106[\%]}{100\%}$$

$$t_{\text{tot DECELERATION TIME}} = t_{P103} + t_{P103} \cdot \frac{P106[\%]}{100\%}$$

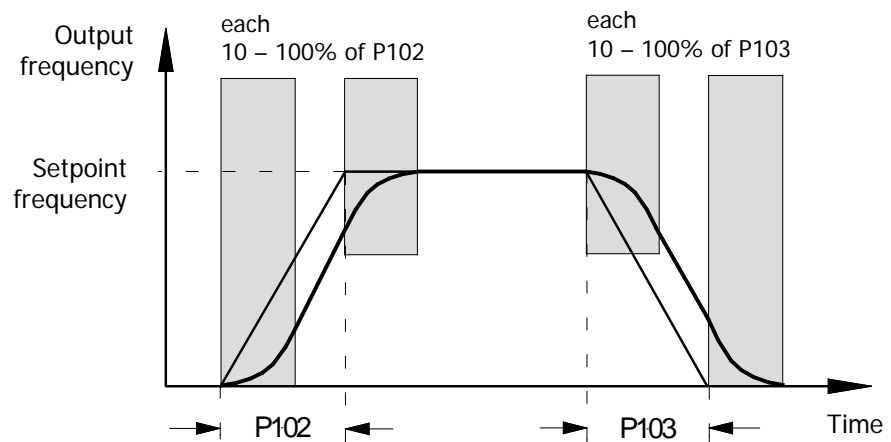

**Note:**

Under the following conditions, ramp rounding-off is switched off or replaced by a linear ramp with extended times:

- Acceleration values (+/-) less than 1 Hz/s
- Acceleration values (+/-) greater than 1 Hz/ms
- Rounding-off values less than 10%

<b>P107</b>	<b>Brake reaction time</b> <i>(brake application time)</i>			<b>P</b>
-------------	---	--	--	----------

0 ... 2.50 s  
{ 0.00 }

Electromagnetic brakes have a physically induced delayed reaction time when applied. This can cause a load drop in lifting applications as the brake takes over the load after a delay.

Take the application time into consideration through the parameter P107 setting.

Within the adjustable application time, the VFD supplies the set absolute minimum frequency (P505) and so prevents movement against the brake and load drop when stopping.

If a time > 0 is set in P107 or P114, the level of the magnetizing current (field current) is checked at the moment the VFD is switched on. If an adequate magnetizing current is not present, the VFD remains in magnetizing mode and the motor brake is not released.

In this case, set P539 to 2 or 3 in order to achieve shutdown and a fault message (E016).

See also the parameter >Release time< P114

**i Information**

**Brake control**

Utilize the relevant connection to the variable frequency drive (please see chapter 2.4.2.4 "Electromechanical brake") to control the electromechanical brake (especially in lifting gears), if available. The absolute minimum frequency (P505) should not be less than 2.0 Hz.

**i Information**

**Torque limitation during active setpoint delay (P107/P114)**

During an active setpoint delay, the torque is limited to a maximum of 160% of the rated torque. This prevents the occurrence of excessive currents in the inverter or the motor stalling if

- the *brake application time* (P107) is set too long when the brake is applied or
- the value for the *absolute minimum frequency* (P505) is set too high when the brake is released.

**Application recommendation:**

Lifting equipment with brake and without speed feedback

P114 = 0.02...0.4 s \*  
 P107 = 0.02...0.4 s \*  
 P201...P208 = motor data  
 P434 = 1 (ext. brake)  
 P505 = 2...4 Hz

for safe startup  
 P112 = 401 (off)  
 P536 = 2.1 (off)  
 P537 = 150%  
 P539 = 2/3 (I<sub>SD</sub> monitoring)

to prevent load drops  
 P214 = 50%...100% (derivative action)

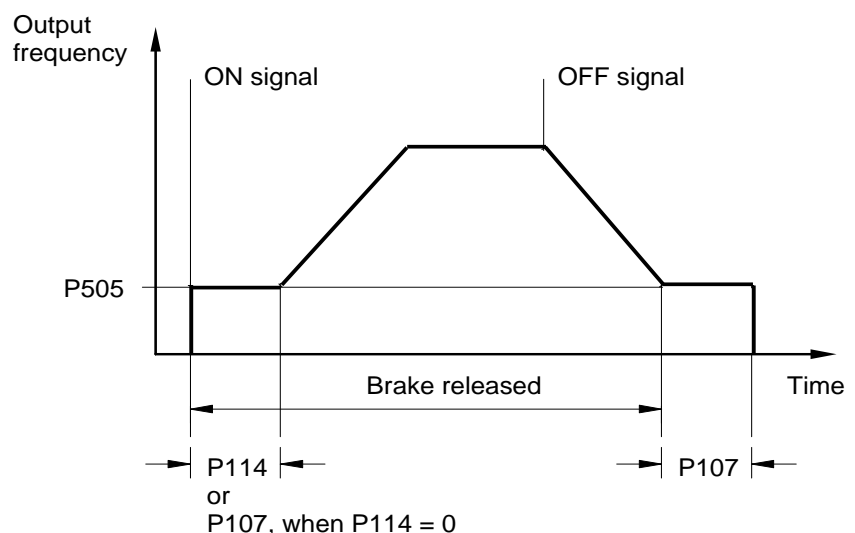

\* Settings (P107/114) depending on brake type and motor size. Lower values apply to low power outputs (< 1.5 kW), higher values apply to higher power outputs (> 4.0 kW).



P108	Disconnection mode <i>(switch-off mode)</i>		S	P
0 ... 13 { 1 }	<p>This parameter determines the manner in which the output frequency is reduced after "blocking" (controller enable → low).</p> <hr/> <p><b>0 = disable voltage:</b> The output signal is switched off immediately. The VFD no longer supplies an output frequency. The motor is only braked by mechanical friction. Immediately switching the VFD on again can lead to a fault message.</p> <p><b>1 = Ramp down:</b> The current output frequency decreases in proportion to the remaining deceleration time, from P103/P105. The DC run-on follows the end of the ramp (→ P559).</p> <p><b>2 = Delayed ramping:</b> same as 1 "Ramp down", but the deceleration ramp is extended during regenerative operation or the output frequency is increased during static operation. Under certain conditions, this function can prevent overvoltage shutdown or reduce braking resistor power loss.</p> <p style="margin-left: 20px;"><b>NOTE:</b> This function must not be programmed if defined deceleration is required, e.g. with lifting gears.</p> <p><b>3 = Instant d.c. braking:</b> The VFD switches immediately to the preselected direct current (P109). This direct current is supplied for the remaining proportion of the &gt;DC brake time&lt; (P110). The &gt;DC brake time&lt; is shortened depending on the ratio of prevailing output frequency to max. frequency (P105). The motor stops at a time that depends on the application. This time depends on the mass inertia of the load, the friction and the DC current set (P109). With this type of braking, no energy is returned to the VFD; heat loss occurs mainly in the motor rotor.</p> <p style="margin-left: 20px;"><b>Not for PMSM motors!</b></p> <p><b>4 = Const. brakedistance, "constant brake distance":</b> The deceleration ramp is delayed in starting if the equipment is <u>not</u> driven at the maximum output frequency (P105). This results in an approximately similar braking distance for different prevailing frequencies.</p> <p style="margin-left: 20px;"><b>NOTE:</b> This function cannot be used as a positioning function. This function should not be combined with a ramp rounding-off (P106).</p> <p><b>5 = Combi. braking, "combined braking":</b> Depending on the prevailing DC link voltage, a high-frequency voltage is switched to the fundamental component (only for linear characteristic curves, P211 = 0 and P212 = 0). Deceleration time (P103) is adhered to if possible. → Additional heating in the motor!</p> <p style="margin-left: 20px;"><b>Not for PMSM motors!</b></p> <p><b>6 = quadratic ramp:</b> The deceleration ramp does not follow a linear path but rather a decreasing quadratic one.</p> <p><b>7 = Quad.Ramp with delay, "quadratic ramp with delay":</b> Combination of functions 2 and 6</p> <p><b>8 = Quad.Ramp w. braking, "quadratic combined braking":</b> Combination of functions 5 and 6.</p> <p style="margin-left: 20px;"><b>Not for PMSM motors!</b></p> <p><b>9 = Constant accn., "constant acceleration power":</b> Only applies to the field weakening range! The drive is accelerated or braked using constant electrical power. The course of the ramps depends on the load.</p> <p><b>10 = Distance Calculator:</b> constant distance between actual frequency/speed and the set minimum output frequency (P104).</p> <p><b>11 = Constant accn.delay, "constant acceleration power with delay":</b> Combination of functions 2 and 9.</p> <p><b>12 = Constant accn. Mode3, "constant acceleration power mode 3":</b> same as 11 but with additional brake chopper relief</p> <p><b>13 = Switch off delay, "ramp down with switch-off delay":</b> same as 1 "Ramp down" but, before the brake is applied, the drive unit remains at the absolute minimum frequency (P505) for the time specified in parameter (P110). Application example: Repositioning during crane control.</p>			

<b>P109</b>	<b>DC brake current</b> <i>(DC brake current)</i>		<b>S</b>	<b>P</b>
0 ... 250 % { 100 }	<p>Current setting for the DC braking (P108 = 3) and combined braking (P108 = 5) functions.</p> <p>The correct setting depends on the mechanical load and the required stopping time. A higher setting can bring large loads to a standstill more quickly.</p> <p>The 100% setting corresponds to a value for current as stored in parameter P203 &gt;Rated current&lt;.</p> <p><b>NOTE:</b> The possible direct current (0 Hz) that the VFD can supply is limited. Please refer to the table in section 8.4.3 "Reduced overcurrent due to output frequency", 0 Hz column, for this value. In the basic setting this limit is 110%.</p> <p><b>DC braking: Not for PMSM motors!</b></p>			
<b>P110</b>	<b>Time DC-brake on</b> <i>(DC brake time on)</i>		<b>S</b>	<b>P</b>
0.00 ... 60.00 s { 2.00 }	<p>The time during which the current selected in parameter P109 is applied to the motor for the "DC braking" function selected in parameter P108 (P108 = 3).</p> <p>The &gt;DC brake time&lt; is shortened depending on the ratio of the prevailing output frequency to the max. frequency (P105).</p> <p>The time starts running when the enable is removed and can be interrupted through a re-enabling.</p> <p><b>DC braking: Not for PMSM motors!</b></p>			
<b>P111</b>	<b>P factor torque limit</b> <i>(P factor torque limit)</i>		<b>S</b>	<b>P</b>
25 ... 400 % { 100 }	<p>Directly affects the behavior of the drive at the torque limit. The basic setting of 100% is sufficient for most drive tasks.</p> <p>If values are too high, the drive tends to vibrate as it reaches the torque limit. If values are too low, the programmed torque limit can be exceeded.</p>			
<b>P112</b>	<b>Torque current limit</b> <i>(torque current limit)</i>		<b>S</b>	<b>P</b>
25 ... 400%/401 { 401 }	<p>A limit for the torque-generating current can be set with this parameter. This can prevent mechanical overloading of the drive. However, it cannot provide any protection against mechanical blocks (movement to stops). A slipping clutch acting as a protective device is essential.</p> <p>The torque current limit can also be set over an infinite range of settings using an analog input. The maximum setpoint (cf. 100% calibration, P403[-01] . .[-06]) then corresponds to the setting in P112.</p> <p>The 20% current torque limit cannot be undershot even by a smaller analog setpoint (P400[-01] ... [-09] = 11 or 12). However, in servo mode ((P300) = "1") a 0% limit is possible as of firmware version V 1.3 (older firmware versions: min. 10%)!</p> <p><b>401 = OFF</b> stands for the torque current limit switch-off! This is also the basic setting for the VFD.</p>			





### 5.2.3 Motor data/characteristic curve parameter







Parameter {factory setting}	Setting value/description/note		Supervisor	Parameter set
<b>P200</b>	<b>Motor list</b> ( <i>motor list</i> )			<b>P</b>
0 ... 73 { 0 }	<p>The motor data factory setting can be changed with this parameter. The factory setting in parameters <b>P201 ... P209</b> is a 4-pole IE1 DS standard motor with the rated VFD output setting. By selecting one of the possible digits and pressing the ENTER key, all of the motor parameters (<b>P201 ... P209</b>) are set to the selected standard power. The motor data is based on a 4-pole three-phase standard motor. The motor data for NORD IE4 motors can be found in the final section of the list.</p> <p><b>Note:</b> As <b>P200</b> is = 0 again after input acknowledgment, the set motor can be controlled via the parameter <b>P205</b>.</p> <hr/> <div style="background-color: #e0e0e0; padding: 5px; display: inline-block;">  <b>Information</b> </div> <hr/> <p>If IE2/IE3 motors are used, after selecting an IE1 motor (<b>P200</b>), the motor data in <b>P201 ... P209</b> must be adapted to the data on the motor nameplate.</p> <hr/> <p><b>NOTE:</b> If DIP switch S1:7 (50/60 Hz operation (chapter 4.3.2.2)) is switched, the corresponding rated motor data according to the rated VFD power output from list P200 is reloaded.</p>			



**0 = No change**

**1 = No motor:** In this setting the VFD operates without current control, slip compensation and pre-magnetizing time, and is therefore not recommended for motor applications. Possible applications are induction furnaces or other applications with coils and transformers. In this case, the following motor data is set:  
50.0 Hz/1500 rpm/15.0 A/400 V/0.00 kW/cos  $\varphi=0.90$ /star/R<sub>s</sub> 0.01  $\Omega$ /I<sub>no-load</sub> 6.5 A

2 = 0.25 kW 230V	32 = 4.0 kW 230V	62 = 90.0 kW 400V	92 = 1.00 kW 115V
3 = 0.33 HP 230V	33 = 5.0 HP 230V	63 = 120.0 HP 460V	93 = 4.0 HP 230V
4 = 0.25 kW 400V	34 = 4.0 kW 400V	64 = 110.0 kW 400V	94 = 4.0 HP 460V
5 = 0.33 HP 460V	35 = 5.0 HP 460V	65 = 150.0 HP 460V	95 = 0.75 kW 230V 80T1/4
6 = 0.37 kW 230V	36 = 5.5 kW 230V	66 = 132.0 kW 400V	96 = 1.10 kW 230V 90T1/4
7 = 0.50HP 230V	37 = 7.5 HP 230V	67 = 180.0 HP 460V	97 = 1.10 kW 230V 80T1/4
8 = 0.37 kW 400V	38 = 5.5 kW 400V	68 = 160.0 kW 400V	98 = 1.10 kW 400V 80T1/4
9 = 0.50HP 460V	39 = 7.5 HP 460V	69 = 220.0 HP 460V	99 = 1.50 kW 230V 90T3/4
10 = 0.55 kW 230V	40 = 7.5 kW 230V	70 = 200.0 kW 400V	100 = 1.50 kW 230V 90T1/4
11 = 0.75HP 230V	41 = 10.0 HP 230V	71 = 270.0 HP 460V	101 = 1.50 kW 400V 90T1/4
12 = 0.55 kW 400V	42 = 7.5 kW 400V	72 = 250.0 kW 400V	102 = 1.50 kW 400V 80T1/4
13 = 0.75HP 460V	43 = 10.0 HP 460V	73 = 340.0 HP 460V	103 = 2.20 kW 230V 100T2/4
14 = 0.75 kW 230V	44 = 11.0 kW 400V	74 = 11.0 kW 230V	104 = 2.20 kW 230V 90T3/4
15 = 1.0 HP 230V	45 = 15.0 HP 460V	75 = 15.0 HP 230V	105 = 2.20 kW 400V 90T3/4
16 = 0.75 kW 400V	46 = 15.0 kW 400V	76 = 15.0 kW 230V	106 = 2.20 kW 400V 90T1/4
17 = 1.0 HP 460V	47 = 20.0 HP 460V	77 = 20.0 HP 230V	107 = 3.00 kW 230V 100T5/4
18 = 1.1 kW 230V	48 = 18.5 kW 400V	78 = 18.5 kW 230V	108 = 3.00 kW 230V 100T2/4
19 = 1.5 HP 230V	49 = 25.0 HP 460V	79 = 25.0 HP 230V	109 = 3.00 kW 400V 100T2/4
20 = 1.1 kW 400V	50 = 22.0 kW 400V	80 = 22.0 kW 230V	110 = 3.00 kW 400V 90T3/4
21 = 1.5 HP 460V	51 = 30.0 HP 460V	81 = 30.0 HP 230V	111 = 4.00 kW 230V 100T5/4
22 = 1.5 kW 230V	52 = 30.0 kW 400V	82 = 30.0 kW 230V	112 = 4.00 kW 400V 100T5/4
23 = 2.0 HP 230V	53 = 40.0 HP 460V	83 = 40.0 HP 230V	113 = 4.00 kW 400V 100T2/4
24 = 1.5 kW 400V	54 = 37.0 kW 400V	84 = 37.0 kW 230V	114 = 5.50 kW 400V 100T5/4
25 = 2.0 HP 460V	55 = 50.0 HP 460V	85 = 50.0 HP 230V	115 =
26 = 2.2 kW 230V	56 = 45.0 kW 400V	86 = 0.12 kW 115V	116 =
27 = 3.0 HP 230V	57 = 60.0 HP 460V	87 = 0.18 kW 115V	117 =
28 = 2.2 kW 400V	58 = 55.0 kW 400V	88 = 0.25 kW 115V	118 =
29 = 3.0 HP 460V	59 = 75.0 HP 460V	89 = 0.37 kW 115V	119 =
30 = 3.0 kW 230V	60 = 75.0 kW 400V	90 = 0.55 kW 115V	120 =
31 = 3.0 kW 400V	61 = 100.0 HP 460V	91 = 0.75 kW 115V	121 =

<b>P201</b>	<b>Nominal frequency</b> (rated motor frequency)		<b>S</b>	<b>P</b>
10.0 ... 399.9 Hz { see information }	The rated motor frequency determines the V/f break point at which the VFD supplies the rated voltage ( <b>P204</b> ) at the output.			
 Information				
<b>Default setting</b> The default setting depends on the rated VFD output or the setting in <b>P200</b> .				
<b>P202</b>	<b>Nominal speed</b> (rated motor speed)		<b>S</b>	<b>P</b>
150 ... 24000 rpm { see information }	The rated motor speed is important for the correct calculation and control of motor slip and the speed display ( <b>P001</b> = 1).			
 Information				
<b>Default setting</b> The default setting depends on the rated VFD output or the setting in <b>P200</b> .				

<b>P203</b>	<b>Nominal current</b> <i>(rated motor current)</i>		<b>S</b>	<b>P</b>
0.1 ... 1000.0 A { see information }	The rated motor current is a decisive parameter for current vector control.			
	 Information			
	<b>Default setting</b> The default setting depends on the rated VFD output or the setting in <b>P200</b> .			
<b>P204</b>	<b>Nominal voltage</b> <i>(rated motor voltage)</i>		<b>S</b>	<b>P</b>
100 ... 800 V { see information }	The rated motor voltage adjusts the line voltage to the motor voltage. In combination with the rated frequency, the voltage/frequency characteristic curve is produced.			
	 Information			
	<b>Default setting</b> The default setting depends on the rated VFD output or the setting in <b>P200</b> .			
<b>P205</b>	<b>Nominal power</b> <i>(Rated motor output)</i>			<b>P</b>
0.00 ... 250.00 kW { see information }	The rated motor output controls the motor set via <b>P200</b> .			
	 Information			
	<b>Default setting</b> The default setting depends on the rated VFD output or the setting in <b>P200</b> .			
<b>P206</b>	<b>Cos phi</b> <i>(motor cos φ)</i>		<b>S</b>	<b>P</b>
0.50 ... 0.95 { see information }	The motor cos φ is a decisive parameter for current vector control.			
	 Information			
	<b>Default setting</b> The default setting depends on the rated VFD output or the setting in <b>P200</b> .			
	 <b>Information</b>	<b>PMSM</b>		
	This parameter is not relevant if a PMSM is used.			
<b>P207</b>	<b>Star Delta con.</b> <i>(motor circuit )</i>		<b>S</b>	<b>P</b>
0 ... 1 { see information }	<b>0 = star                      1 = delta</b> The motor circuit is crucial for stator resistance measurement ( <b>P220</b> ) and therefore critical for current vector control.			
	 Information			
	<b>Default setting</b> The default setting depends on the rated VFD output or the setting in <b>P200</b> .			

<b>P208</b>	<b>Stator resistance</b> ( <i>stator resistance</i> )		<b>S</b>	<b>P</b>
0.00 ... 300.00 Ω { see information }	<p>Motor stator resistance ⇒ Resistance of a phase winding with a three-phase motor.</p> <p>Has a direct effect on current control of the VFD. Too high a value can lead to overcurrent; too low a value to low motor torque.</p> <p>Parameter <b>P220</b> can be used for simple measurement. Parameter <b>P208</b> can be used for manual setting or as information about the result of an automatic measurement.</p> <p><b>Note:</b></p> <p>For optimum functioning of current vector control, stator resistance must be measured automatically by the VFD.</p>			
 Information				
<p><b>Default setting</b></p> <p>The default setting depends on the rated VFD output or the setting in <b>P200</b>.</p>				
<b>P209</b>	<b>No load current</b> ( <i>no load current</i> )		<b>S</b>	<b>P</b>
0.0 ... 1000.0 A { see information }	<p>This value is always calculated automatically from motor data if there is a change in parameter <b>P206</b> “cos φ” and parameter <b>P203</b> “Nominal current”.</p> <p><b>Note:</b> If the value is to be entered directly, then it must be set as the last of the motor data. This is the only way to ensure that the value will not be overwritten.</p>			
 Information				
<p><b>Default setting</b></p> <p>The default setting depends on the rated VFD output or the setting in <b>P200</b>.</p>				
<b>P210</b>	<b>Static boost</b> ( <i>static boost</i> )		<b>S</b>	<b>P</b>
0 ... 400 % { 100 }	<p>Static boost affects the current which generates the magnetic field. This is equivalent to the no-load current of the respective motor and is therefore <u>load-independent</u>. The no-load current is calculated using the motor data. The factory setting of 100% is sufficient for typical applications.</p>			
<b>P211</b>	<b>Dynamic boost</b> ( <i>dynamic boost</i> )		<b>S</b>	<b>P</b>
0 ... 150 % { 100 }	<p>Dynamic boost affects the torque-generating current and is therefore a load-dependent parameter. The factory setting of 100% is also sufficient for typical applications.</p> <p>Too high a value can result in overcurrent in the VFD. The output voltage will then rise too sharply under load. Too low a value will lead to insufficient torque.</p>			
 <b>Information</b>				
<p><b>V/f characteristic curve</b></p> <p>With certain applications, particularly those with high centrifugal mass (e.g. fan drives), it may be necessary to control the motor with the aid of a U/f characteristic curve. In order to do this, set parameters <b>P211</b> and <b>P212</b> each to 0%.</p>				
<b>P212</b>	<b>Slip compensation</b> ( <i>slip compensation</i> )		<b>S</b>	<b>P</b>
0 ... 150 % { 100 }	<p>Slip compensation increases the output frequency depending on load in order to keep the DC asynchronous motor speed approximately constant.</p> <p>The factory setting of 100% is optimal when using DC asynchronous motors and correct motor data has been set.</p> <p>If several motors (different loads or outputs) are run with one VFD, set slip compensation P212 to 0%. This excludes any negative effects. With PMSM motors, the parameter must be left at the factory setting.</p>			

**i Information**

**V/f characteristic curve**

With certain applications, particularly those with high centrifugal mass (e.g. fan drives), it may be necessary to control the motor with the aid of a U/f characteristic curve. In order to do this, set parameters **P211** and **P212** each to 0%.

**i Information**

**PMSM**

When controlling a PMSM, this parameter determines the voltage of the test signal method (**P330**). The required voltage depends on various factors (ambient and motor temperature, motor size, motor cable length, size of variable frequency drive). If the rotor position identification is not successful, this parameter can be used to adjust the voltage.

<b>P213</b>	<b>ISD ctrl. loop gain</b> <i>(amplification ISD control)</i>		<b>S</b>	<b>P</b>
25 ... 400 % { 100 }	This parameter affects the control dynamics of the VFD current vector control (ISD control). Higher settings make the controller faster, lower settings slower. Depending on the type of application, this parameter can be adjusted to avoid unstable operation for example.			
<b>P214</b>	<b>Torque precontrol</b> <i>(torque derivative action)</i>		<b>S</b>	<b>P</b>
-200 ... 200 % { 0 }	This function allows a value for the expected torque requirement to be set in the current controller. This function can be used in lifting gears for better load transfer during startup. <b>NOTE:</b> In clockwise rotary field direction, motor torques are entered with a positive sign, while regenerative torques are entered with a negative sign. The reverse applies to counterclockwise rotation.			
<b>P215</b>	<b>Boost precontrol</b> <i>(boost derivative action)</i>		<b>S</b>	<b>P</b>
0 ... 200 % { 0 }	Only advisable in linear characteristic curves (P211 = 0% and P212 = 0%). For drives that require a high starting torque, this parameter provides an option for adding an additional current during the start phase. The operative time is limited and can be selected in parameter P216 >Boost derivative action time<. All current and torque current limits that may have been set (P112, P536, P537) are deactivated during the boost derivative action time. <b>NOTE:</b> With active ISD control (P211 and/or P212 ≠ 0%), parameterization of P215 ≠ 0 results in incorrect control.			
<b>P216</b>	<b>Time boost prectrl.</b> <i>(boost derivative action time)</i>		<b>S</b>	<b>P</b>
0.0 ... 10.0 s { 0.0 }	This parameter is used for 3 functions:  <b>Time limit</b> for <b>boost derivative action</b> : Operative time for increased starting current. Only in linear characteristic curves (P211 = 0% and P212 = 0%). <b>Time limit</b> for <b>suppression of pulse switch-off</b> (P537): enables heavy starting. <b>Time limit</b> for <b>suppression of switch-off on error</b> in parameter (P401), setting { 05 } "0 - 10 V with switch-off on error 2"			



<b>P217</b>	<b>Oscillation damping</b> <i>(oscillation damping)</i>		<b>S</b>	<b>P</b>
0 ... 400 % { 10 }	<p>No-load resonance vibrations can be damped with oscillation damping. Parameter 217 is a measure of the damping capacity.</p> <p>In oscillation damping the oscillation component is filtered out of the torque current by means of a high-pass filter. This is amplified by P217 and inverted to the output frequency.</p> <p>The limit for the applied value is also proportional to P217. The time constant for the high-pass filter depends on P213. For higher values of P213 the time constant is lower.</p> <p>With a value of 10% for P217, a maximum of <math>\pm 0.045</math> Hz is applied. With 400% in P217, this corresponds to <math>\pm 1.8</math> Hz.</p> <p>The function is not active in "Servo mode, P300".</p>			
<b>P218</b>	<b>Modulation depth</b> <i>(modulation depth)</i>		<b>S</b>	
50 ... 110 % { 100 }	<p>This setting affects the maximum possible output voltage of the VFD in relation to the line voltage. Values &lt;100% reduce the voltage to values below that of the line voltage if this is required for motors. Values &gt;100% increase the output voltage on the motor. This leads to increased harmonics in the current and can lead to oscillations in some motors.</p> <p>Normally this should be set to 100%.</p>			

<b>P219</b>	<b>Auto. magn. adjustment</b> <i>(automatic magnetization adjustment)</i>		<b>S</b>	
25 ... 100 %/101 { 100 }	<p>With this parameter, magnetization can be automatically matched to the motor load so that energy consumption is reduced to the actual requirement. P219 is a limiting value, to which the field in the motor can be reduced.</p> <p>The value is set to 100% by default and therefore no reduction is possible. A minimum of 25% can be set.</p> <p>The field is reduced with a time constant of approx. 7.5 s. Upon load increase the field is built up again with a time constant of approx. 300 ms. The reduction of the field is carried out so that the magnetization current and the torque current are approximately equal, so that the motor is operated with optimum efficiency. No field increase above the setpoint is provided.</p> <p>This function is intended for applications in which the required torque only changes slowly (e.g. pumps and fans). Its effect therefore replaces a quadratic curve since it adapts the voltage to the load.</p> <p><b>This parameter does not function for the operation of synchronous motors (IE4 motors).</b></p> <p><b>NOTE:</b> This must not be used for lifting gears or applications where a more rapid build-up of the torque is required, as otherwise there would be overcurrent switch-offs or motor stalling on sudden changes of load because the missing field will have to be compensated by a disproportionate torque current.</p> <p><b>101 = automatic</b>, with the setting P219=101 an automatic magnetization current controller is activated. The ISD controller then operates with a subordinate flow controller which improves the slippage calculation, especially at higher loads. Rise times are considerably faster compared to normal ISD control (P219 = 100).</p>			

**P2xx Control/characteristic curve parameter**

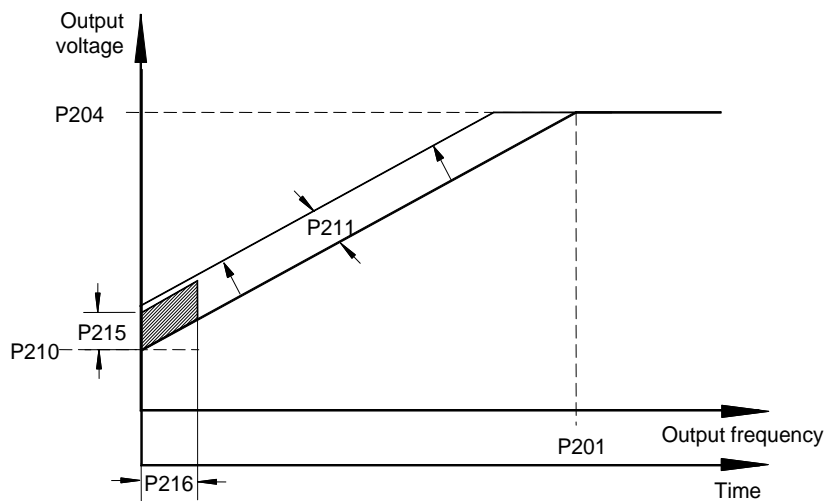

**NOTE:**  
"typical"

Settings for...

**Current vector control (factory setting)**

- P201 to P209 = motor data
- P210 = 100%
- P211 = 100%
- P212 = 100%
- P213 = 100%
- P214 = 0%
- P215 = no significance
- P216 = no significance

**Linear V/f characteristic curve**

- P201 to P209 = motor data
- P210 = 100% (static boost)
- P211 = 0%
- P212 = 0%
- P213 = no significance
- P214 = no significance
- P215 = 0% (boost derivative action)
- P216 = 0 s (dyn. boost time)

P220	<b>Par. identification</b> <i>(parameter identification)</i>		P						
0 ... 2 { 0 }	<p>In devices with output of up to 22 KW the motor data is determined automatically by the device via these parameters. In many cases, better drive behavior is achieved with the measured motor data.</p> <p>The identification of all parameters takes some time. <b>Do not switch off</b> the line voltage <b>during this time</b>. If there is unfavorable operating behavior after identification, select a suitable motor in P200 or set parameters P201 ... P208 manually.</p> <p><b>0 = no identification</b>  <b>1 = identification R<sub>s</sub>:</b>                The stator resistance (display in P208) is determined by multiple measurements.</p> <p><b>2 = motor identification:</b>                This function can only be used in devices of up to 22 KW.                <b>ASM:</b> all motor parameters (P202, P203, P206, P208, P209) are determined.                <b>PMSM:</b> stator resistance (P208) and inductance (P241) are determined.</p> <p>Please note: Motor identification should only be carried out on a cold motor (15°C ... 25°C). Warming up of the motor is taken into account during operation.</p> <p>The VFD must be in the "ready for operation" state. For BUS operation, the BUS must operate without error.</p> <p>The motor output may only be one output level greater or 3 output levels lower than the rated output of the VFD.</p> <p>A maximum motor cable length of 20 m must be maintained for reliable identification.</p> <p>Before starting motor identification, the motor data must be preset in accordance with the nameplate or P200. The rated frequency (P201), the rated speed (P202), the voltage (P204), the output (P205) and the motor circuit (P207) must at least be known.</p> <p>Make sure that the connection to the motor is not interrupted during the entire measuring process. If identification cannot be concluded successfully, error message E019 is generated.</p> <p>After identification of parameters, P220 is again = 0.</p>								
P240	<b>EMF voltage PMSM</b> <i>(PMSM EMF voltage)</i>		S      P						
0 ... 800 V { 0 }	<p>The EMF constant describes the mutual induction voltage of the motor. The value to be set can be found on the data sheet for the motor or on the nameplate and is scaled to 1000 rpm. As the rated speed of the motor is not usually 1000 rpm, this must be converted accordingly:</p> <p><b>Example:</b></p> <table style="width: 100%; border-collapse: collapse;"> <tr> <td style="width: 50%;">E (EMF constant, nameplate):</td> <td style="width: 50%;">89 V</td> </tr> <tr> <td>Nn (rated speed of motor):</td> <td>2100 rpm</td> </tr> </table> <hr style="border: 0.5px solid black;"/> <table style="width: 100%; border-collapse: collapse;"> <tr> <td style="width: 50%;">Value in P240</td> <td style="width: 50%;"> <math>P240 = E \cdot Nn / 1000</math>  <math>P240 = 89 \text{ V} \cdot 2100 \text{ rpm} / 1000 \text{ rpm}</math>  <b>P240 = 187 V</b> </td> </tr> </table> <p><b>0 = ASM is used, "asynchronous machine is used":</b> No compensation</p>	E (EMF constant, nameplate):	89 V	Nn (rated speed of motor):	2100 rpm	Value in P240	$P240 = E \cdot Nn / 1000$ $P240 = 89 \text{ V} \cdot 2100 \text{ rpm} / 1000 \text{ rpm}$ <b>P240 = 187 V</b>		
E (EMF constant, nameplate):	89 V								
Nn (rated speed of motor):	2100 rpm								
Value in P240	$P240 = E \cdot Nn / 1000$ $P240 = 89 \text{ V} \cdot 2100 \text{ rpm} / 1000 \text{ rpm}$ <b>P240 = 187 V</b>								



### 5.2.4 Control parameter

In combination with an HTL incremental encoder, a closed speed control loop can be set up using digital inputs 2 and 3 of the VFD.

Alternatively, the incremental encoder signal can also be used in another way. In order to do this, select the required function in parameter P325.

In order to make this parameter visible, set the supervisor parameter P003 to 2 or 3.

Parameter {factory setting}	Setting value/description/note	Device	Supervisor	Parameter set
<b>P300</b>	<b>Servo mode</b> ( <i>servo mode</i> )			<b>P</b>
0 ... 2 { 0 }	<p>The control method for the motor is defined with this parameter. The following constraints must be observed: In comparison with the "0" setting, the "2" setting enables somewhat higher dynamics and control precision but it requires greater parameterization effort. In contrast, the "1" setting operates with speed feedback from an encoder and therefore enables the highest possible quality of speed control and dynamics.</p> <p><b>0 = Off (VFC open-loop)</b><sup>1)</sup>      Speed control without encoder feedback</p> <p><b>1 = On (CFC closed-loop)</b><sup>2)</sup>      Speed control with encoder feedback</p> <p><b>2 = Obs (CFC open-loop)</b>      Speed control without encoder feedback</p> <p><b>NOTE:</b> Commissioning information: (📖 Section 4.2 "Selecting the operating mode for motor control").</p> <p>1) Corresponds to the previous setting "OFF" 2) Corresponds to the previous setting "ON"</p>			
<div style="display: flex; align-items: center;"> <div style="background-color: #e0e0e0; padding: 5px; margin-right: 10px;"><b>i</b> Information</div> <div> <p style="text-align: center;"><b>Operation of an IE4 motor with (P330), setting 1 = On (CFC closed-loop)</b></p> <p>If an IE4 motor is operated in CFC closed-loop mode, the <b>slip error monitoring</b> must be <b>activated (P327 ≠ 0)</b>.</p> </div> </div>				
<b>P301</b>	<b>Incremental encoder</b> ( <i>encoder resolution</i> )			
0 ... 19 { 6 }	<p>Input of the pulse number per revolution of the connected incremental encoder.</p> <p>If the encoder rotation direction is not the same as that of the VFD (depending on installation and wiring), this can be compensated for by selecting the corresponding negative pulse numbers 8...16 or 19.</p>			

<b>0</b> = 500 pulses	<b>8</b> = -500 pulses
<b>1</b> = 512 pulses	<b>9</b> = -512 pulses
<b>2</b> = 1000 pulses	<b>10</b> = -1000 pulses
<b>3</b> = 1024 pulses	<b>11</b> = -1024 pulses
<b>4</b> = 2000 pulses	<b>12</b> = -2000 pulses
<b>5</b> = 2048 pulses	<b>13</b> = -2048 pulses
<b>6</b> = 4096 pulses	<b>14</b> = -4096 pulses
<b>7</b> = 5000 pulses	<b>15</b> = -5000 pulses
	<b>16</b> = -8192 pulses
<b>17</b> = 8192 pulses	
<b>18</b> = 1024 SLCA <sup>1)</sup>	<b>19</b> = -1024 SLCA <sup>1)</sup>

- 1) The settings 18 and 19 are specially intended for use of a Contelec magnetic encoder with 1024 pulses / encoder revolution.

**NOTE:**

(P301) is also relevant to positioning control through incremental encoders. If an incremental encoder is used for positioning (P604=1), the setting of the pulse number per revolution is entered here. (see supplementary POSICON manual)

<b>P310</b>	<b>Speed Controller P</b> <i>(speed controller P)</i>			<b>P</b>
0 ... 3200 % { 100 }	<p>P component of the speed controller (proportional amplification). Amplification factor by which the speed difference between the setpoint and actual frequency is multiplied. A value of 100% means that a speed difference of 10% produces a setpoint of 10%. Values that are too high can cause the output speed to oscillate.</p>			
<b>P311</b>	<b>Speed Controller I</b> <i>(speed controller I)</i>			<b>P</b>
0 ... 800%/ms { 20 }	<p>I component of the speed controller (integration component). The integration component of the controller enables the complete elimination of any control deviation. The value indicates how large the setpoint change is per ms. Values that are too small cause the controller to slow down (reset time is too long).</p>			
<b>P312</b>	<b>Torque current controller P</b> <i>(torque current controller P)</i>		<b>S</b>	<b>P</b>
0 ... 1000 % { 400 }	<p>Current controller for the torque current. The higher the current controller parameter, the more precisely the current setpoint maintained. Excessively high values in P312 generally lead to high-frequency oscillations at low speeds. On the other hand, excessively high values in P313 mostly produce low-frequency oscillations across the whole speed range. If the value "zero" is entered in P312 and P313, then torque current control is switched off. In this case, only the motor model derivative action is used.</p>			
<b>P313</b>	<b>Torque current controller I</b> <i>(torque current controller I)</i>		<b>S</b>	<b>P</b>
0 ... 800%/ms { 50 }	<p>I component of the torque current controller. (See also P312 &gt;Torque current controller P&lt;)</p>			
<b>P314</b>	<b>Torque current controller limit</b> <i>(Torque current controller limit)</i>		<b>S</b>	<b>P</b>
0 ... 400 V { 400 }	<p>Determines the maximum voltage span of the torque current controller. The higher the value, the greater the maximum effect that can be exercised by the torque current controller. Excessive values in P314, in particular, can lead to instability during transition to the field weakening range (see P320). The values for P314 and P317 should always be set roughly the same so that the field and torque current controllers are balanced.</p>			
<b>P315</b>	<b>Field current controller P</b> <i>(field current controller P)</i>		<b>S</b>	<b>P</b>
0 ... 1000 % { 400 }	<p>Current controller for the field current. The higher the current controller parameters, the more precisely the current setpoint maintained. Excessively high values for P315 generally lead to high-frequency vibrations at low speeds. On the other hand, excessively high values in P316 mostly produce low-frequency vibrations across the whole speed range. If the value "zero" is entered in P315 and P316, then the field current controller is switched off. In this case, only the motor model derivative action is used.</p>			
<b>P316</b>	<b>Field current controller I</b> <i>(field current controller I)</i>		<b>S</b>	<b>P</b>
0 ... 800%/ms { 50 }	<p>I component of the field current controller. See also P315 &gt;Field current controller P&lt;</p>			

<b>P317</b>	<b>Field current controller limit</b> <i>(field current controller limit)</i>		<b>S</b>	<b>P</b>
0 ... 400 V { 400 }	Determines the maximum voltage span of the field current controller. The higher the value, the greater the maximum effect that can be exercised by the field current controller. Excessive values in P317, in particular, can lead to instability during transition to the field weakening range (see P320). The values for P314 and P317 should always be set roughly the same so that the field and torque current controllers are balanced.			
<b>P318</b>	<b>P-Weak</b> <i>(field weakening controller P)</i>		<b>S</b>	<b>P</b>
0 ... 800 % { 150 }	The field weakening controller reduces the field setpoint when the synchronous speed is exceeded. The field weakening controller has no function in the basic speed range. For this reason, the field weakening controller only needs to be set if speeds are set above the rated motor speed. Excessive values for P318/P319 will lead to controller oscillations. The field is not weakened sufficiently if the values are too small or during dynamic acceleration and/or delay times. The downstream current controller can no longer read the current setpoint.			
<b>P319</b>	<b>I-Weak</b> <i>(field weakening controller I)</i>		<b>S</b>	<b>P</b>
0 ... 800%/ms { 20 }	Only affects the field weakening range, see P318 >Field weakening controller P<			
<b>P320</b>	<b>Field weakening limit</b> <i>(field weakening controller limit)</i>		<b>S</b>	<b>P</b>
0 ... 110 % { 100 }	The field weakening limit determines the speed/current at which the controller begins to weaken the field. At a set value of 100% the controller begins to weaken the field at approximately the synchronous speed.  If values much larger than the standard values have been set in P314 and/or P317, then the field weakening limit should be reduced accordingly so that the control range is actually available to the current controller.			
<b>P321</b>	<b>Speed ctr. I brake off</b> <i>(speed controller I release time)</i>		<b>S</b>	<b>P</b>
0 ... 4 { 0 }	The I component of the speed controller is increased during the brake release time (P107/P114). This leads to better load take-up, especially with suspended loads.  <b>0</b> = P311 speed control I x 1 <b>1</b> = P311 speed control I x 2 <b>2</b> = P311 speed control I x 4 <b>3</b> = P311 speed control I x 8 <b>4</b> = P311 speed control I x 16			



<b>P325</b>	<b>Function encoder</b> <i>(rotary encoder function)</i>		<b>S</b>	
0 ... 4 { 0 }	<p>The actual speed value supplied by an incremental encoder can be used for various functions in the VFD.</p> <p><b>0 = speed meas. Servom, "Servo mode speed measurement":</b> The actual motor speed value is used for the VFD servo mode. ISD control cannot be switched off in this function.</p> <p><b>1 = PID actual frequency:</b> The actual speed of a system is used for speed control. This function can also be used to control a motor with a linear characteristic curve. It is also possible to use an incremental encoder not mounted directly on the motor for speed control. P413 – P416 determine the control.</p> <p><b>2 = frequency addition:</b> The calculated speed is added to the prevailing setpoint.</p> <p><b>3 = frequency subtraction:</b> The calculated speed is subtracted from the prevailing setpoint.</p> <p><b>4 = maximum frequency:</b> The maximum possible output frequency/speed is limited by the speed of the encoder.</p>			
<b>P326</b>	<b>Ratio encoder</b> <i>(encoder ratio)</i>		<b>S</b>	
0.01 ... 100.0 { 1.00 }	<p>If the incremental encoder is not mounted directly on the motor shaft, then the correct transformation ratio of motor speed to encoder speed must be set.</p> $P326 = \frac{\text{Motor speed}}{\text{Encoder speed}}$ <p>Only when P325 = 1, 2, 3 or 4, that is, not in servo mode (motor speed control)</p>			
<b>P327</b>	<b>Speed slip error</b> <i>(speed controller slip error)</i>		<b>S</b>	<b>P</b>
0 ... 3000 rpm { 0 }	<p>The limit for a permitted maximum slip error can be set. If this value is reached, the VFD switches off and indicates error <b>E013.1</b>. The slip error monitoring functions both with active and inactive servo mode (<b>P300</b>).</p> <p><b>0 = OFF</b></p> <p>Only when <b>P325</b> = 0, that is, in servo mode (motor speed control).</p> <p>(also see  <b>P328</b>)</p>			
<b>P328</b>	<b>Speed slip error delay</b> <i>(slip error delay)</i>		<b>S</b>	<b>P</b>
0.0 ... 10.0 s { 0.0 }	<p>If the permissible speed slip error defined in (P327) is exceeded, fault message E013.1 is suppressed within the time limits which are set here.</p> <p><b>0.0 = OFF</b></p>			

<b>P330</b>	<b>Rotor starting position detection</b> <i>(rotor starting position detection)</i>		<b>S</b>	
(Former designation: "Regulation PMSM ")				
0 ... 3 { 0 }	Selection of the method for determining the starting position of the rotor (initial value of rotor position) of a PMSM (permanent-magnet synchronous motor). The parameter is only relevant for the control method "CFC closed-loop" (P300, setting "1").			
<p><b>0 = Voltage-control:</b> With the first start of the machine, a voltage indicator is imprinted and ensures that the machine rotor is set to rotor position "zero". This type of rotor starting position can only be used if there is no counter-torque from the machine (e.g. flywheel drive) at frequency "zero". If this condition is fulfilled, this method of determining the rotor position is very precise (&lt;1° electrical). In principle, this method is not suitable for lifting gears since there is always a counter-torque.</p> <p><u>The following applies to encoder-less operation:</u> Up to the changeover frequency P331 the motor (with the rated current imprinted) is driven under voltage control. Once the changeover frequency is reached, the method for determining the rotor position is switched over to the EMF method. If the frequency falls below the value in (P331) taking hysteresis (P332) into account, the variable frequency drive switches from the EMF method back to voltage-controlled operation.</p> <p><b>1 = Test signal principle:</b> The starting position of the rotor is determined with a test signal. This method also functions at a standstill with the brake applied but it requires a PMSM with sufficient anisotropy between the inductance of the d and q axes. The higher this anisotropy, the greater the precision of the method. The voltage level of the test signal can be adjusted by means of parameter (P212) and the position of the rotor position controller can be adjusted with parameter (P213). In principle, a rotor position accuracy of 5°...10° can be achieved electrically in motors suitable for the test signal method (depending on the motor and the anisotropy).</p> <p><b>2 = Reserved</b></p> <p><b>3 = value CANopen encoder, "value of the CANopen encoder":</b> In this method the rotor starting position is determined from the absolute position of a CANopen absolute encoder. The type of CANopen absolute encoder is set in parameter (P604). For this position information to be unique, it must be known (or determined) how this rotor position relates to the absolute position of the CANopen absolute encoder. This is performed via the offset parameter (P334). Motors should be delivered either with a rotor starting position of "zero" or the rotor starting position must be noted on the motor. If this value is not available, the offset value can also be determined with settings "0" and "1" of the parameter (P330). For this purpose, the drive unit is started with the setting "0" or "1". After the first start, the calculated offset value is in parameter (P334). However, this value is volatile, that is, saved only in the random access memory. To copy it to the EEPROM, it must be briefly adjusted and then reset to the calculated value. Fine adjustment can also be carried out with the motor running under no load. The drive is operated in closed-loop mode (P300=1) at as high a speed as possible below the field weakening point. From the starting point, the offset is gradually adjusted so that the value of the voltage component <math>U_d</math> (P723) is as close to zero as possible. A balance between the positive and negative direction of rotation should be sought. In general, the "zero" value is not reached completely since the drive is under very light load at higher speeds from the motor's fan propeller. The CANopen absolute encoder should be located on the motor axis.</p>				

<b>P331</b>	<b>Switch over freq. CFC ol</b> <i>(Switch over frequency CFC open-loop)</i>  (Former designation: " <b>Switch over freq. PMSM</b> ")		<b>S</b>	<b>P</b>
5.0 ... 100.0 % { 15.0 }	Definition of the frequency from which the control method of a PMSM (permanent-magnet synchronous motor) is activated according to (P300) in operation without encoder. In this case, 100% corresponds to the rated motor frequency from (P201).  The parameter is only relevant for the control method "CFC open-loop" (P300, setting "2").			
<b>P332</b>	<b>Hyst. Switchover CFC ol</b> <i>(Switchover frequency hysteresis CFC open-loop)</i>  (Former designation: " <b>Hyst. Switchover PMSM</b> ")		<b>S</b>	<b>P</b>
0.1 ... 25.0 % { 5.0 }	Difference between the switch-on and switch-off point in order to prevent oscillation in the transition from operation without encoder to the control method specified in (P330) (and vice versa).			
<b>P333</b>	<b>Flux feedback CFC ol</b> <i>(Flux feedback CFC open-loop)</i>  (Former designation: " <b>Flux feedb. fact. PMSM</b> ")		<b>S</b>	<b>P</b>
5 ... 400 % { 25 }	This parameter is necessary for the position monitor in CFC open-loop mode. The higher the value selected, the lower the flux error from the rotor position monitor. However, higher values also limit the lower limit frequency of the position monitor. The greater the feedback amplification selected, the higher the limit frequency and the higher the values that must be set in (P331) and (P332). This conflict of objectives therefore cannot be resolved simultaneously for both optimization objectives.  The default value is selected so that it typically does not need to be adjusted for NORD IE4 motors.			
<b>P334</b>	<b>Encoder offset PMSM</b> <i>(PMSM encoder offset)</i>		<b>S</b>	
-0,500 ... 0.500 rev { 0,000 }	Evaluation of the zero track is needed to operate PMSMs (permanent-magnet synchronous motors). The zero pulse is then used to synchronize the rotor position. Set parameter (P330) to "0" or "1".  The value to be set for parameter (P334) (offset between zero pulse and actual rotor position "zero") must be determined experimentally or included with the motor.  A sticker is typically affixed to motors supplied by NORD on which the setting is specified.  If the information on the motor is specified in °, this must be converted to <b>rev</b> (e.g. 90° = 0.250 rev).			
<b>Note</b> <ul style="list-style-type: none"> <li>– The zero track is connected via <b>digital input 1</b>.</li> <li>– Set parameter P420 [-01] to function 43 "0 track HTL encoder DI1" in order to evaluate the pulses of the zero track.</li> </ul>				

<b>P336</b>	<b>Mode rotorpos. ident.</b>	<b>S</b>
	<i>(Rotor position identification mode)</i>	
0 ... 2 { 6 }	<p>The exact position of the rotor must be known in order to operate a PMSM. This can be determined by various methods.</p> <p><b>0 = First enable</b> Identification of the PMSM rotor position is performed when the drive is enabled for the first time.</p> <p><b>1 = Supply voltage</b> Identification of the PMSM rotor position is performed when the supply voltage is applied for the first time.</p> <p><b>2 = DIN/BUS IO IN</b> Identification of the PMSM rotor position is triggered by an external order by means of a binary bit (digital input (P420) or Bus-in bit (480), setting "79", "Rotorpos. Ident.").</p> <p><b>NOTE:</b>          Identification of the rotor position is only performed if the VFD is in the "ready to switch-on" state and the rotor position is not known (see P434, P481 function 28).          Use of the parameter is only advisable if the test signal method is set (P330).</p>	
<b>P350</b>	<b>PLC functionality</b>	<b>S</b>
	<i>(PLC functionality)</i>	
0 ... 1 { 0 }	<p>Activation of the integrated PLC</p> <p><b>0 = Off:</b> the PLC is not active, the variable frequency drive is actuated in accordance with parameters (P509) and (P510).</p> <p><b>1 = On:</b> the PLC is active, variable frequency drive is actuated via the PLC depending on (P351). The main setpoints must be defined accordingly in parameter (P553). Auxiliary setpoints (P510[-02]) can still be defined via (P546).</p>	
<b>P351</b>	<b>PLC Setvalue selection</b>	<b>S</b>
	<i>(PLC setpoint selection)</i>	
0 ... 3 { 0 }	<p>Selection of the source for the control word (CTW) and the main setpoint (MSW) with active PLC functionality (P350 = 1). With the settings "0" and "1", the main setpoints are defined via (P553), but the definition of the auxiliary setpoints remains unchanged via (P546). This parameter is only accepted if the variable frequency drive is in "ready for switch-on" status.</p> <p><b>0 = CTW &amp; MSW = PLC:</b> The PLC supplies the control word (CTW) and the main setpoint (MSW), and parameters (P509) and (P510[-01]) have no function.</p> <p><b>1 = CTW= P509:</b> The PLC supplies the main setpoint (MSW), the control word (CTW) corresponds to the setting in parameter (P509).</p> <p><b>2 = MSW = P510[1]:</b> The PLC supplies the control word (CTW), the source for the main setpoint (MSW) corresponds to the setting in parameter (P510[-01]).</p> <p><b>3 = CTW &amp; MSW = P509/510:</b> The source for the control word (CTW) and the main setpoint (MSW) corresponds to the setting in parameter (P509)/(P510[-01]).</p>	

<b>P353</b>	<b>Bus status via PLC</b> <i>(Bus status via PLC)</i>		<b>S</b>	
0 ... 3 { 0 }	<p>This parameter can be used to determine how the control word (CTW) for the master function and the status word (STW) of the variable frequency drive undergo further processing by the PLC.</p> <p><b>0 = Off:</b> The control word (CTW) of the master function (P503≠0) and the status word (STW) undergo further processing by the PLC without change.</p> <p><b>1 = CTW for broadcast:</b> The control word (CTW) for the master value function (P503≠ 0) is set by the PLC. In order to do this, the control word must be redefined accordingly in the PLC using process value "34_PLC_Busmaster_Control_word".</p> <p><b>2 = STW for bus:</b> The status word (STW) of the variable frequency drive is set by the PLC. In order to do this, the status word must be redefined accordingly in the PLC using process value "28_PLC_status_word".</p> <p><b>3 = CTW Broadcast&amp;STWBus:</b> See <i>setting 1 and 2</i></p>			
<b>P355</b> [-01] ... [-10]	<b>PLC integer setvalue</b> <i>(PLC integer setpoint)</i>		<b>S</b>	
0x0000 ... 0xFFFF all = { 0 }	Data can be exchanged with the PLC via this INT array. This data can be used by the appropriate process variables in the PLC.			
<b>P356</b> [-01] ... [-05]	<b>PLC long setvalue</b> <i>(PLC long setpoint)</i>		<b>S</b>	
0x0000 0000 ... 0xFFFF FFFF all = { 0 }	Data can be exchanged with the PLC via this DINT array. This data can be used by the appropriate process variables in the PLC.			
<b>P360</b> [-01] ... [-05]	<b>PLC display value</b> <i>(PLC display value)</i>		<b>S</b>	
-2 000 000,000 ... 2 000 000,000 all = { 0.000 }	The parameter is only used to display the PLC date. This parameter can be written by the PLC via the corresponding process variables. The values are not saved!			
<b>P370</b>	<b>PLC status</b> <i>(PLC status)</i>		<b>S</b>	
0 ... 63 <sub>dec</sub>  <i>Parameter Box:</i> 0x00 ... 0x3F  <i>Simple Box/Control Box:</i> 0x00 ... 0x3F  all = { 0 }	<p>Displays the actual status of the PLC.</p> <p><b>Bit 0 = P350=1:</b> Parameter P350 was set in the "Activate internal PLC" function</p> <p><b>Bit 1 = PLC active:</b> The internal PLC is active.</p> <p><b>Bit 2 = Stop active:</b> The PLC program is in "Stop" status.</p> <p><b>Bit 3 = Debug active:</b> Error checking of the PLC program is running.</p> <p><b>Bit 4 = PLC fault:</b> The PLC has an error but PLC user errors 23.xx are not displayed here.</p> <p><b>Bit 5 = PLC stopped:</b> The PLC program was stopped (<i>single step or breakpoint</i>).</p>			

### 5.2.5 Control terminals

Parameter {factory setting}	Setting value/description/note		Supervisor	Parameter set
<b>P400</b> [-01] ... [-09]	<b>Setpoint I/P Funct.</b> <i>(input setpoint functions)</i>	<b>SK 2x0E</b>		<b>P</b>
0 ... 36	<b>SK 2x0E size 1 ... 3</b>	<b>SK 2x0E size 4</b>		
{ [-01] = 1 }	<b>[-01] Analog input 1</b> , function of analog input 1 integrated into the VFD			
{ [-02] = 0 }	<b>[-02] Analog input 2</b> , function of analog input 2 integrated into the VFD			
{ [-03] = 0 }	<b>[-03] External analog input 1</b> , AIN1 of the <u>first</u> I/O extension (SK xU4-IOE)			
{ [-04] = 0 }	<b>[-04] External analog input 2</b> , AIN2 of the <u>first</u> I/O extension (SK xU4-IOE)			
{ [-05] = 1 }	<b>[-05] Setpoint module</b>			
{ [-06] = 0 }	<b>[-06] Digital input 2</b> , can be set to pulse signal evaluation via P420 [-02] =26 or 27. The pulses can then be evaluated in the VFD as an analog signal according to the function set here.	<b>[-06] Potentiometer 1</b> , function of potentiometer P1 integrated into the VFD. DIP switches 4/5 must be "off" so that the function can be affected by this parameter setting (chapter 4.3.2.2)		
{ [-07] = 1 }	<b>[-07] Digital input 3</b> , can be set to pulse signal evaluation via P420 [-03] =26 or 27. The pulses can then be evaluated in the VFD as an analog signal according to the function set here.	<b>[-07] Potentiometer 2</b> , same as potentiometer 1		
{ [-08] = 0 }	<b>[-08] External analog in. 1 2nd IOE</b> , "External analog input 1 2nd IOE", AIN1 of the <u>second</u> I/O extension (SK xU4-IOE) (= analog input 3)			
{ [-09] = 0 }	<b>[-09] External analog in. 2 2nd IOE</b> , "External analog input 2 2nd IOE", AIN2 of the <u>second</u> I/O extension (SK xU4-IOE) (= analog input 4)			

... Setting values below

<b>P400</b> [-01] ... [-09]	<b>Setpoint I/P Funct</b> <i>(input setpoint functions)</i>	<b>SK 2x5E</b>		<b>P</b>
0 ... 36	<b>[-01] Potentiometer 1</b> , function of potentiometer P1 integrated into the VFD. DIP switches 4/5 must be "off" so that the function can be affected by this parameter setting (chapter 4.3.2.2)			
{ [-01] = 1 }	<b>[-02] Potentiometer 2</b> , same as potentiometer 1			
{ [-02] = 15 }	<b>[-03] External analog input 1</b> , AIN1 of the <u>first</u> I/O extension (SK xU4-IOE)			
{ [-03] = 0 }	<b>[-04] External analog input 2</b> , AIN2 of the <u>first</u> I/O extension (SK xU4-IOE)			
{ [-04] = 0 }	<b>[-05] Setpoint module</b>			
{ [-05] = 1 }	<b>[-06] Digital input 2</b> , can be set to pulse signal evaluation via parameter P420 [-02] =26 or 27. The pulses can then be evaluated in the VFD as an analog signal according to the function set here.			
{ [-06] = 0 }	<b>[-07] Digital input 3</b> , can be set to pulse signal evaluation via parameter P420 [-03] =26 or 27. The pulses can then be evaluated in the VFD as an analog signal according to the function set here.			
{ [-07] = 1 }	<b>[-08] Ext. AI 1 2.IOE</b> , "External analog input 1 2nd IOE", AIN1 of the <u>second</u> I/O extension (SK xU4-IOE) (= analog input 3)			
{ [-08] = 0 }	<b>[-09] Ext. analog in. 2 2nd IOE</b> , "External analog input 2 2nd IOE", AIN2 of the <u>second</u> I/O extension (SK xU4-IOE) (= analog input 4)			
{ [-09] = 0 }				

The basic versions of SK 2x5E devices do not have an analog input. An analog function can only be used by using options (array [-01]...[-05] and [-08]...[-09]) or using digital input 2 or 3 (array [-06]...[-07]).

... Setting values below

For standardization of actual values: (📖 Section 8.9 "Standardization of setpoint/target values").

- 0 = Off**, the analog input has no function. After the VFD is enabled via the control terminals, it will supply the set minimum frequency (P104).
- 1 = Setpoint frequency**, the given analog range (P402/P403) varies the output frequency between the set minimum and maximum frequencies (P104/P105).
- 2 = Frequency addition \*\***, the supplied frequency value is added to the setpoint.
- 3 = Frequency subtraction \*\***, the supplied frequency value is subtracted from the setpoint.
- 4 = Minimum frequency**, is a typical setting for the functionality of the *potentiometer* (P1 or P2) on the SK 2x5E or the *analog input* (AIN1 or AIN2) on the SK 2x0E.  
SK 2x0E: lower limit: 1 Hz  
Standardization:  $T_{\min. \text{ frequency}} = 50 \text{ Hz} \cdot U[V] / 10 \text{ V}$  (U=voltage potentiometer (P1 or P2)) or U = voltage at analog input (AIN1 or AIN2)
- 5 = Maximum frequency** is a typical setting for the functionality of the *potentiometer* (P1 or P2) on the SK 2x5E or the *analog input* (AIN1 or AIN2) on the SK 2x0E.  
SK 2x0E: lower limit: 2 Hz  
Standardization:  $T_{\max. \text{ frequency}} = 100 \text{ Hz} \cdot U[V] / (U = \text{voltage potentiometer (P1 or P2)})$  or U = voltage at analog input (AIN1 or AIN2)
- 6 = Cur. value process controller \***, activates the process controller, analog input is connected to the actual value encoder (compensator, pressure box, flow volume meter, etc.). The mode is set via the DIP switches of the I/O extension or in (P401).
- 7 = Nom. value process controller \***, same as function 6 but the setpoint is specified (e.g. by a potentiometer). The actual value must be specified using another input.
- 8 = PI current frequency \***, is required to build up a control loop. The analog input (actual value) is compared with the setpoint (e.g. fixed frequency). The output frequency is adjusted as far as possible until the actual value equals the setpoint. (see control variables P413...P414)
- 9 = PI limited current freq.\***, "*Actual frequency PI limited*", same as function 8 "Actual frequency PI" but the output frequency cannot fall below the programmed minimum frequency value in parameter P104. (no change to rotation direction)
- 10 = PI monitored current freq.\***, "*Actual frequency PI monitored*", same as function 8 "Actual frequency PI" but the VFD switches the output frequency off when the minimum frequency P104 is reached
- 11 = Torque current limit**, "*Torque current limited*" depends on parameter (P112). This value corresponds to 100% of the setpoint. When the set limit is reached, there is a reduction of the output frequency at the torque current limit.
- 12 = Torque current limit off**, "*Torque current limit switch-off*" depends on parameter (P112). This value corresponds to 100% of the setpoint. When the set limit is reached, the device switches off with error code E12.3.
- 13 = Current limit**, "*Current limited*" depends on parameter (P536). This value corresponds to 100% of the setpoint. When the set limit is reached, the output voltage is reduced in order to limit the output current.
- 14 = Current limit off**, "*Current limit switch-off*", depends on parameter (P536). This value corresponds to 100% of the setpoint. When the set limit is reached, the device switches off with error code E12.4.
- 15 = Ramp time**, (only SK 2x0E size 4 and SK 2x5E) is a typical setting for the function of potentiometer P1 or P2 (P400 [01] or [02]), which are integrated in the VFD cover (📖Section 4.3.2 "Configuration").  
SK 2x0E: lower limit: 50 ms  
Standardization:  $T_{\text{ramp time}} = 10 \text{ s} \cdot U[V] / 10 \text{ V}$  (U=voltage of potentiometer (P1 or P2))
- 16 = Pre-tension Torque**, a function that enables a value for the torque requirement to be entered beforehand in the controller (interference factor application). This function can be used to improve loading of lifting equipment with separate load detection.
- 17 = Multiplication**, the setpoint is multiplied with the analog value indicated. The analog value adjusted to 100% then corresponds to a multiplication factor of 1.



- 18 = Curve control**, the master receives the prevailing speed from the slave via the external analog input (P400 [-03] or P400 [-04]) or via the BUS (P546 [-01 .. -03]). The master calculates the prevailing setpoint speed from its own speed, the slave speed and the guide speed so that neither of the two drives travels faster than the guide speed in the curve.
- 19 = Servo mode torque**, in servo mode ((P300)= "1") the motor torque can be set/limited using this function. As of firmware version V1.3 this function is also without speed feedback but it can be used at a lower quality.
- 25 = Ratio gearing**, "*gear transmission factor*", is a multiplier to compensate for the variable transmission of a setpoint. E.g.: Setting of transmission between master and slave by means of a potentiometer.
- 26 = ...reserved**, for Posicon, see [BU0210](#)
- 30 = Motor temperature**, enables measurement of motor temperature with a KTY-84 temperature sensor (📖 Section 4.4 "Temperature sensors").
- 33 = Setval.torque p.reg.**, "*Setpoint torque process controller*", for even distribution of torques to coupled drive units (e.g.: S roller drive). This function is also possible with the use of ISD control.
- 34 = d-corr. F Process** - (diameter correction, frequency PI /process controller).
- 35 = d-corr. Torque** - (diameter correction, torque).
- 36 = d-corr. F+Torque** - (diameter correction, frequency PI/process controller and torque).

\*) Please refer to section 8.2 "Process controller" for further details about the PI and process controller.

\*\*) The limits of these values are formed by the parameters >minimum frequency auxiliary setpoints< (P410) and the parameter >maximum frequency auxiliary setpoints< (P411), whereby the limits defined by (P104) and (P105) cannot be undershot or overshot.

<b>P401</b> [-01] ... [-06]	<b>Mode Analog input</b> <i>(analog input mode)</i>	<b>S</b>
0 ... 5 { all 0 }	<p>This parameter determines how the variable frequency drive reacts to an analog signal which is less than the 0% adjustment (P402).</p> <hr/> <p><b>[-01] Ext. Analog input 1</b>, AIN1 of the <u>first</u> I/O extension  <b>[-02] Ext. Analog input 2</b>, AIN2 of the <u>first</u> I/O extension  <b>[-03] Ext. AI 1 2. IOE</b>, "<i>External analog input 1 2nd IOE</i>", AIN1 of the <u>second</u> I/O extension  <b>[-04] Ext. AI 2 2. IOE</b>, "<i>External analog input 2 2nd IOE</i>", AIN2 of the <u>second</u> I/O extension  <b>[-05] Analog input 1</b>, Analog input 1 (only SK 200E, SK 210E)  <b>[-06] Analog input 2</b>, Analog input 2 (only SK 2x0E)</p>	
	<p><b>0 = 0 – 10V limited:</b> An analog setpoint less than the programmed 0% adjustment (P402) does not lead to undershooting of the programmed minimum frequency (P104), i.e. it does not result in a change in the direction of rotation.</p> <p><b>1 = 0 – 10V:</b> If a setpoint less than the programmed 0% adjustment (P402) is present, this can cause a change in rotation direction. This allows rotation direction reversal using a simple voltage source and potentiometer.</p> <p><u>E.g. internal setpoint with rotation direction change:</u> P402 = 5 V, P104 = 0 Hz, Potentiometer 0-10 V → Rotation direction change at 5 V in mid-range setting of the potentiometer.</p> <p>At the moment of reversal (hysteresis = ± P505), the drive stands still when the minimum frequency (P104) is less than the absolute minimum frequency (P505). A brake controlled by the VFD is applied in the hysteresis range.</p> <p>If the minimum frequency (P104) is greater than the absolute minimum frequency (P505), the drive reverses when the minimum frequency is reached. In the hysteresis range ± P104, the VFD supplies the minimum frequency (P104), the brake controlled by the VFD is not applied.</p>	



**2 = 0 – 10V controlled:** If the minimum adjusted setpoint (P402) is undershot by 10% of the differential value from P403 and P402, the VFD output switches off. Once the setpoint is greater than  $[P402 - (10\% * (P403 - P402))]$ , it will deliver an output signal again. With the change to firmware version V 2.0 R0, the behavior of the VFD changes in that the function is only active if a function for the relevant input has been selected in P400.

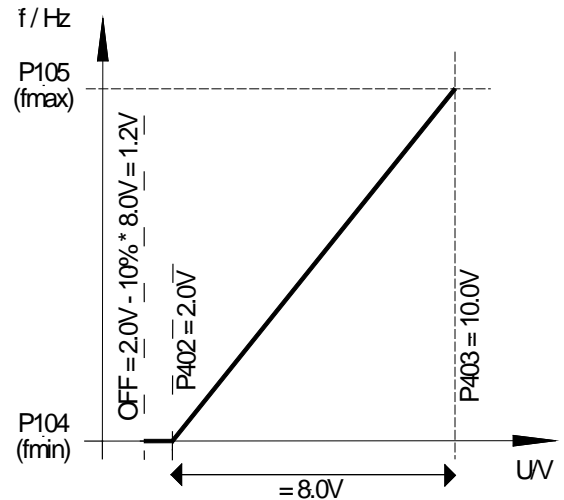

e.g. setpoint 4-20 mA: P402: 0% adjustment = 1 V; P403: 100% adjustment = 5 V; -10% corresponds to -0.4 V; i.e. 1...5 V (4...20 mA) normal operating zone, 0.6...1 V = minimum frequency setpoint, below 0.6 V (2.4 mA) output switches off.

**3 = - 10V – 10V:** If a setpoint less than the programmed 0% adjustment (P402) is present, this can cause a change in rotation direction. This allows rotation direction reversal using a simple voltage source and potentiometer.

E.g. internal setpoint with rotation direction change: P402 = 5 V, P104 = 0 Hz, Potentiometer 0-10 V → Rotation direction change at 5 V in mid-range setting of the potentiometer.

At the moment of reversal (hysteresis =  $\pm$  P505), the drive stands still when the minimum frequency (P104) is less than the absolute minimum frequency (P505). A brake controlled by the VFD is not applied in the hysteresis range.

If the minimum frequency (P104) is greater than the absolute minimum frequency (P505), the drive reverses when the minimum frequency is reached. In the hysteresis range  $\pm$  P104, the VFD supplies the minimum frequency (P104), the brake controlled by the VFD is not applied.

**NOTE:** The function -10 V – 10 V is a description of the function and not a reference to a bipolar signal (see example above).

**4 = 0 – 10V with error 1, "0 – 10 V with error switch-off 1":**

If the value of the 0% adjustment in (P402) is undershot, error message 12.8

"Undershooting of Analog In Min." is activated.

If the value of the 100% adjustment in (P402) is undershot, error message 12.9 "Undershoot of Analog In Max." is activated.

Even if the analog value is outside the limits defined in (P402) and (P403), the setpoint is limited to 0% - 100%.

The monitoring function only becomes active if an enable signal is present and the analog value has reached the valid range ( $\geq$ (P402) or  $\leq$ (P403)) for the first time (e.g. pressure buildup after switching on a pump).

*Once the function has been activated, it also operates if the actuation takes place via a field bus, for example, and the analog input is not actuated at all.*

**5 = 0 – 10V with error 2, "0 – 10 V with error switch-off 2":**

See setting 4 ("0 - 10 V with error switch off 1") but:

In this setting the monitoring function only becomes active if an enable signal is present and the time during which the error monitoring is suppressed has elapsed. This suppression time is set in parameter (P216).

<b>P402</b> [-01] ... [-06]	<b>Adjust: 0%</b> <i>(analog input adjustment: 0%)</i>	<b>S</b>	
-50.00 ... 50.00 V { all 0.00 }	<p>[ -01 ] <b>Ext. Analog in 1</b>, AIN1 of the <u>first</u> I/O extension (SK xU4-IOE)</p> <p>[ -02 ] <b>Ext. Analog in 2</b>, AIN2 of the <u>first</u> I/O extension (SK xU4-IOE)</p> <p>[ -03 ] <b>Ext. AI 1 2. IOE</b>, "External analog input 1 2nd IOE", AIN1 of the <u>second</u> I/O extension (SK xU4-IOE) (= analog input 3)</p> <p>[ -04 ] <b>Ext. AI 2 2. IOE</b>, "External analog input 2 2nd IOE", AIN2 of the <u>second</u> I/O extension (SK xU4-IOE) (= analog input 4)</p> <p>[ -05 ] <b>Analog input 1</b>, Analog input 1 (only SK 200E, SK 210E)</p> <p>[ -06 ] <b>Analog input 2</b>, Analog input 2 (only SK 2x0E)</p>		
<p>This parameter sets the voltage which should correspond to the minimum value of the selected function for analog input 1 or 2. In the factory setting (setpoint) this value corresponds to the setpoint set via P104 &gt;Minimum frequency&lt;.</p> <p><b>Note</b>  <u>SK 2x0E</u>          For the adjustment of the analog inputs integrated in the <u>SK2x0E</u> to the type of analog signals, the following values must be set:</p> <p>0 - 10V → 0.00 V          2 - 10V → 2.00 V          0 - 20mA → 0.00 V (enable internal resistance via DIP switch!)          4 - 20mA → 1.00 V (enable internal resistance via DIP switch!)</p> <p>DIP switches: (please see chapter 4.3.2.3 "DIP switches, analog input (only SK 2x0E)")</p> <p><u>SK xU4-IOE</u>          Standardization to typical signals such as 0(2)-10 V or 0(4)-20 mA is carried out via the DIP switch on the I/O-extension module. In this case, additional adjustment of parameters (P402) and (P403) must <u>not</u> be carried out.</p>			
<b>P403</b> [-01] ... [-06]	<b>Adjust: 100%</b> <i>(analog input adjustment: 100%)</i>	<b>S</b>	
-50.00 ... 50.00 V { all 10.00 }	<p>[ -01 ] <b>Ext. Analog in 1</b>, AIN1 of the <u>first</u> I/O extension (SK xU4-IOE)</p> <p>[ -02 ] <b>Ext. Analog in 2</b>, AIN2 of the <u>first</u> I/O extension (SK xU4-IOE)</p> <p>[ -03 ] <b>Ext. AI 1 2. IOE</b>, "External analog input 1 2nd IOE", AIN1 of the <u>second</u> I/O extension (SK xU4-IOE) (= analog input 3)</p> <p>[ -04 ] <b>Ext. AI 2 2. IOE</b>, "External analog input 2 2nd IOE", AIN2 of the <u>second</u> I/O extension (SK xU4-IOE) (= analog input 4)</p> <p>[ -05 ] <b>Analog input 1</b>, Analog input 1 (only SK 200E, SK 210E)</p> <p>[ -06 ] <b>Analog input 2</b>, Analog input 2 (only SK 2x0E)</p>		

This parameter sets the voltage, which should correspond with the maximum value of the selected function for the analog input 1 or 2. In the factory setting (setpoint) this value is corresponds to the setpoint which is set via P105 >Maximum frequency<.

**Note**

SK 2x0E

For the adjustment of the analog inputs integrated in the SK2x0E to the type of analog signals, the following values must be set:

0 - 10V → 10.00 V

2 - 10V → 10.00 V

0 - 20mA → 5.00 V (enable internal resistance via DIP switch!)

4 - 20mA → 5.00 V (enable internal resistance via DIP switch!)

DIP switches: (please see chapter 4.3.2.3 "DIP switches, analog input (only SK 2x0E)")

SK xU4-IOE

Standardization to typical signals such as 0(2)-10 V or 0(4)-20 mA is carried out via the DIP switch on the I/O-extension module. In this case, additional adjustment of parameters (P402) and (P403) must not be carried out.

<b>P404</b>	<b>[-01] Filter Analogeingang</b> <b>[-02] (Analog input filter)</b>	<b>SK 2x0E</b>	<b>S</b>	
-------------	---	----------------	----------	--

10 ... 400 ms  
{ all 100 }

Adjustable digital low-pass filter for the analog signal. Interference peaks are hidden, the reaction time is extended.

**[-01] = analog input 1:** analog input 1 integrated in the device

**[-02] = analog input 2:** analog input 2 integrated in the device

The filter time for the analog inputs of the optional external IO extension modules is set in the parameter set for the relevant module (P161).

**P400 ... P403**

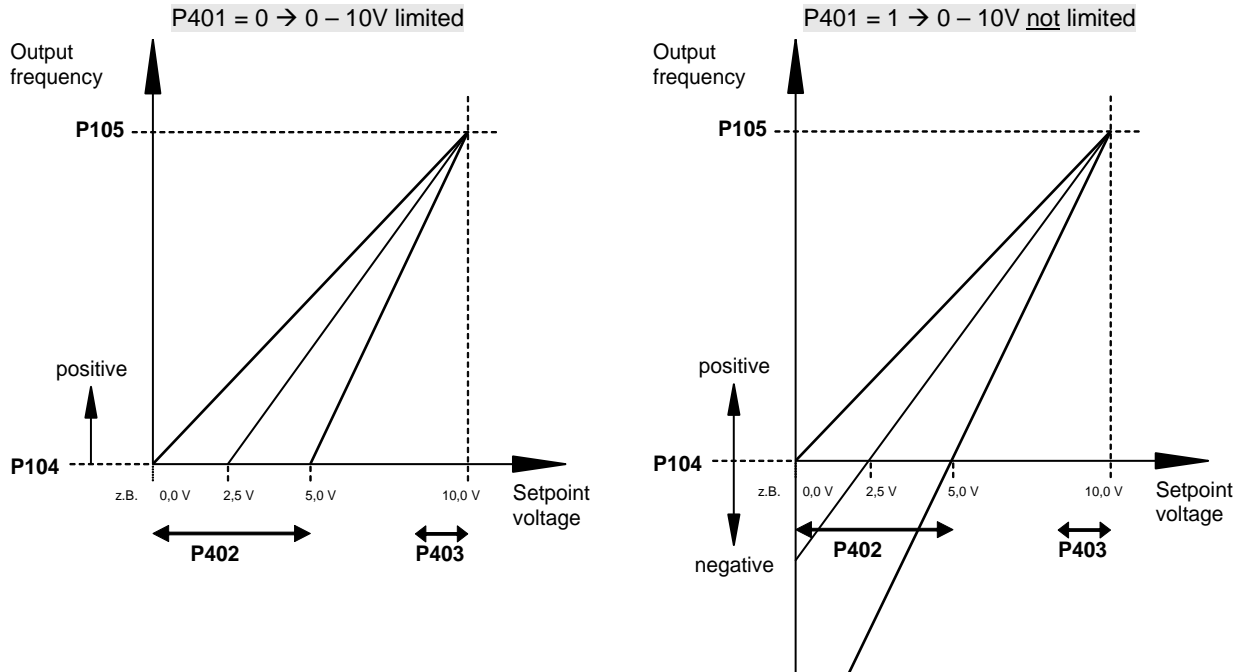

<b>P410</b>	<b>Min. freq. a-in 1/2</b> <i>(minimum frequency auxiliary setpoints)</i>			<b>P</b>
-400.0 ... 400.0 Hz { 0.0 }	The minimum frequency that can act on the setpoint via the auxiliary setpoints. Auxiliary setpoints are all frequencies that are additionally delivered for further functions in the VFD:  PID actual frequency                      Frequency addition Auxiliary setpoints via BUS                      Frequency subtraction min. frequency above analog setpoint (potentiometer)                      Process controller			
<b>P411</b>	<b>Max. freq. a-in 1/2</b> <i>(Maximum frequency auxiliary setpoints)</i>			<b>P</b>
-400.0 ... 400.0 Hz { 50.0 }	The maximum frequency that can act on the setpoint via the auxiliary setpoints. Auxiliary setpoints are all frequencies that are additionally delivered for further functions in the VFD:  PID actual frequency                      Frequency addition Auxiliary setpoints via BUS                      Frequency subtraction max. frequency over analog setpoint (potentiometer)                      Process controller			

<b>P412</b>	<b>Nom.val process ctrl</b> <i>(setpoint process controller)</i>		<b>S</b>	<b>P</b>
-10.0 ... 10.0 V { 5.0 }	Fixed specification of a setpoint for the process controller that will only occasionally be altered. Only with P400 = 14 ... 16 (process control) 8.2 "Process controller".			
<b>P413</b>	<b>PI -control P comp.</b> <i>(P component of PI controller)</i>		<b>S</b>	<b>P</b>
0.0 ... 400.0 % { 10.0 }	This parameter is only effective when the function PI controller actual frequency is selected. The P component of the PI controller determines the frequency jump if there is a control deviation based on the control difference. E.g.: At a setting of P413 = 10% and a rule difference of 50%, 5% is added to the actual setpoint.			
<b>P414</b>	<b>PI control I comp.</b> <i>(I component of PI controller)</i>		<b>S</b>	<b>P</b>
0.0 ... 3000.0 %/s { 10.0 }	This parameter is only effective when the function PI controller actual frequency is selected. The I component of the PI controller determines the frequency change, dependent on time. <b>Note:</b> In contrast to other NORD series, parameter P414 is smaller by a factor of 100 (Reason: better setting ability with small I-proportions).			
<b>P415</b>	<b>Process control limit</b> <i>(Process controller control limit)</i>		<b>S</b>	<b>P</b>
0 ... 400.0 % { 10.0 }	This parameter is only effective when the function <b>PI process control</b> is selected. This determines the control limit (%) after the PI controller (please see chapter 8.2 "Process controller").			
<b>P416</b>	<b>Ramp time PI setpoint</b> <i>(ramp time PI setpoint)</i>		<b>S</b>	<b>P</b>
0.00 ... 99.99 s { 2.00 }	This parameter is only effective when the function PI process controller is selected. Ramp for PI setpoint			
<b>P417</b> [-01] ... [-02]	<b>Offset analog output</b> <i>(offset analog output)</i>		<b>S</b>	<b>P</b>
-10.0 ... 10.0 V { all 0.0 }	<b>[-01] = IOE-1, AOUT of the <u>first</u> I/O extension (SK xU4-IOE)</b> <b>[-02] = IOE-2, AOUT of the <u>second</u> I/O extension (SK xU4-IOE)</b>			
... only with SK CU4-IOE or SK TU4-IOE	In the analog output function an offset can be entered to simplify the processing of the analog signal in other equipment. If the analog output has been programmed with a digital function, then the difference between the switch-on point and the switch-off point can be set in this parameter (hysteresis).			

P418 [-01] ... [-02]	Analog output func. (analog output function)	S	P
0 ... 60 { all 0 }	<b>[-01] = IOE-1</b> <ul style="list-style-type: none"> <li>AOUT of the first I/O extension (type SK xU4-IOE) or</li> <li>AOUT1 of an I/O extension of type SK xU4-IOE2</li> </ul>		
	<b>[-02] = IOE-2</b> <ul style="list-style-type: none"> <li>AOUT of the second I/O extension (type SK xU4-IOE)</li> <li>AOUT2 of an I/O extension of type SK xU4-IOE2</li> </ul>		

... only with  
SK CU4-IOE or  
SK TU4-IOE

**Analog functions** (max. load: 5 mA analog):

An analog voltage (0 ... +10 V) can be obtained at the control terminals (max. 5 mA). Various functions are available, whereby:

- 0 V analog voltage always corresponds to 0% of the selected value.
- 10 V always corresponds to the rated motor value (unless otherwise stated) multiplied by the P419 standardization factor, e.g.:

$$\Rightarrow 10 \text{ Volt} = \frac{\text{Rated motor value} \times \text{P419}}{100\%}$$

For standardization of actual values: (📖 Section 8.9 "Standardization of setpoint/target values").

- 0 = No function**, no output signal at the terminals.
- 1 = Actual frequency \***, the analog voltage is proportional to the VFD output frequency. (100%=(P201))
- 2 = Actual speed \***, this is the synchronous speed calculated by the VFD based on the existing setpoint. Load-dependent speed fluctuations are not taken into account. If servo mode is used, the measured speed will be output via this function. (100%=(P202))
- 3 = Current \***, the effective value of the output current supplied by the VFD. (100%=(P203))
- 4 = Torque current \***, displays the motor load torque calculated by the VFD. (100% = (P112))
- 5 = Voltage \***, the output voltage supplied by the VFD. (100%=(P204))
- 6 = D.c. link voltage, "DC link voltage"**, the DC voltage in the VFD. This is not based on the rated motor data. 10 V with 100% standardization corresponds to 450 V DC (230 V line power) or 850 V DC (480 V line power)!
- 7 = Value of P542**, the analog output can be set using parameter P542 independently of the actual operating status of the VFD. For example, with bus switching (parameter command) this function can supply an analog value from the VFD, which is triggered by the control unit.
- 8 = Apparent power \***, the actual apparent power of the motor as calculated by the VFD. (100%=(P203)\*(P204) or = (P203)\*(P204)\*√3)
- 9 = Real power\***, the actual effective power calculated by the VFD. (100%=(P203)\*(P204)\*(P206) or = (P203)\*(P204)\*(P206)\*√3)
- 10 = Torque [%] \***, the actual torque calculated by the VFD (100%=rated motor torque).
- 11 = Field [%] \***, the actual field in the motor calculated by the VFD.
- 12 = Actual frequency ± \***, the analog voltage is proportional to the output frequency of the VFD, whereby the zero point is shifted to 5 V. For rotation to the right, values between 5 V and 10 V are output, and for rotation to the left values between 5 V and 0 V.
- 13 = Speed ± \***, is the synchronous rotation speed calculated by the VFD, based on the current setpoint, where the zero point has been shifted to 5 V. Values of 5 V to 10 V are output with right-hand rotation, and values of 5 V to 0 V with left-hand rotation. The measured speed is output via this function if servo mode is used.
- 14 = Torque [%] ± \***, is the actual torque calculated by the VFD, whereby the zero point is shifted to 5 V. For drive torques, values between 5 V and 10 V are output, and for generator torque, values between 5 V and 0 V.
- 29 = Reserved**, for POSICON, see [BU0210](#)

- 30 = Set freq. befor ramp**, "Setpoint frequency before frequency ramp", displays the frequency produced by any upstream controllers (ISD, PID, ...). This is then the target frequency for the power stage after it has been adjusted via the startup or braking ramp (P102, P103).
- 31 = Output via BUS PZD**, the analog output is controlled via a bus system. The process data is transferred directly (P546 = "32").
- 33 = Set freq Motorpot**, "Set point frequency of motor potentiometer"
- 60 = Value of PLC**, the analog output is set by the integrated PLC, independently of the current operating status of the VFD.

\*) Values are based on the motor data (P201...) or are calculated from this.

<b>P419</b> [-01] [-02]	<b>Analog output scal.</b> (standardization of analog output)		<b>S</b>	<b>P</b>
-500 ... 500 % { all 100 }	[-01] = <b>IOE-1</b> , AOUT of the <u>first</u> I/O extension (SK xU4-IOE) [-02] = <b>IOE-2</b> , AOUT of the <u>second</u> I/O extension (SK xU4-IOE)			
... only with SK CU4-IOE or SK TU4-IOE	<p>Using this parameter an adjustment can be made to the analog output for the selected working range. The maximum analog output (10 V) corresponds to the standardization value of the appropriate selection.</p> <p>Therefore, if this parameter is raised from 100% to 200% at a constant working point, the analog output voltage is halved. 10 Volt output signal then corresponds to twice the nominal value.</p> <p>For negative values the logic is reversed. An actual value of 0% will then produce 10 V at the output and -100% will produce 0 V.</p>			
<b>P420</b> [-01] ... [-04]	<b>Digital inputs</b> (Digital inputs)			
0 ... 80 { [-01]= 1 } { [-02]= 2 } { [-03]= 4 } { [-04]= 5 }	<p>Up to 4 freely programmable digital inputs are available depending on the version. The functions can be seen in the following table.</p> <p><b>[-01] Digital input 1 (DIN1), Enable right</b> (default), control terminal 21</p> <p><b>[-02] Digital input 2 (DIN2), Enable left</b> (default), control terminal 22</p> <p><b>[-03] Digital input 3 (DIN3), Fixed frequency 1</b> (default), control terminal 23</p> <p><b>[-04] Digital input 4 (DIN4), Fixed frequency 2</b> (default), control terminal 24 (DIN4 not with SK 21xE and SK 23xE: Recommended for these devices if "Safe stop" is used: Parameterize DIN4 to function "10" "Disable voltage" → Error message E18.0 suppressed when "Safe stop" triggered)</p> <p>When an encoder is being used, digital inputs DIN 2 and DIN 3 must be disabled using an OR operation of the parameterized functionality and the encoder evaluation that are always active in the VFD (parameter P420 [-02, -03]).</p> <p>The additional digital inputs of the I/O extensions (SK xU4-IOE) are managed via the parameter "Bus I/O In Bit (4...7)" - (P480 [-05] ... [-08]) for the <u>first</u> I/O extension, and via the parameter "Bus I/O In Bit (0...3)" - (P480 [-01] ... [-04]) for the <u>second</u> I/O extension.</p>			

### List of possible functions of digital inputs P420

Value	Function	Description	Signal
<b>00</b>	No function	Input switched off.	---
<b>01</b>	Enable right	The VFD delivers an output signal with the rotation field right if a positive setpoint is present: 0 → 1 flank (P428 = 0)	High
<b>02</b>	Enable left	The VFD delivers an output signal with the rotation field left if a positive setpoint is present: 0 → 1 flank (P428 = 0)	High

Value	Function	Description	Signal
		<p>If the drive is to start up automatically when the line voltage is switched on (P428 = 1), a permanent high level must be provided for enabling (supply control terminal 21 with 24 V).</p> <p>If the "Enable right" and "Enable left" functions re actuated simultaneously, the VFD is blocked.</p> <p>If the variable frequency drive is in fault status but the cause of the fault no longer exists, the error message is acknowledged with a <b>1 → 0 flank</b>.</p>	
<b>03</b>	Phase seq. reserval	Causes the rotation field to change direction in combination with Enable right or left.	High
<b>04</b> <sup>1</sup>	Fixed frequency 1	The frequency from P465 [01] is added to the actual setpoint value.	High
<b>05</b> <sup>1</sup>	Fixed frequency 2	The frequency from P465 [02] is added to the actual setpoint value.	High
<b>06</b> <sup>1</sup>	Fixed frequency 3	The frequency from P465 [03] is added to the actual setpoint value.	High
<b>07</b> <sup>1</sup>	Fixed frequency 4	The frequency from P465 [04] is added to the actual setpoint value.	High
		If several fixed frequencies are actuated at the same time, they are added with the correct sign. In addition, the analog setpoint (P400) and if necessary the minimum frequency (P104) are added.	
<b>08</b> <sup>5</sup>	Para Set Switching <i>"Parameter set changeover 1"</i>	Selection of active parameter set 1...4 - first bit.	High
<b>09</b>	Hold frequency	During the acceleration or deceleration phase, a low level will cause the actual output frequency to be "Held". A high level allows the ramp to proceed.	Low
<b>10</b> <sup>2</sup>	Voltage disable	The VFD output voltage is switched off; the motor coasts to a stop.	Low
<b>11</b> <sup>2</sup>	Quick stop	The VFD reduces the frequency according to the programmed quick stop time from P426.	Low
<b>12</b> <sup>2</sup>	Fault acknowledgem.	Fault acknowledgement with an external signal. If this function is not programmed, a fault can also be acknowledged by a low enable setting (P506).	0→1 flank
<b>13</b> <sup>2</sup>	PTC resistor input	Only with the use of a temperature monitor (bimetallic switching contact). Switch-off delay = 2 s, warning after 1 s.	High
<b>14</b> <sup>2,4</sup>	Remote control	With bus system control, a low level switches the control to control via the control terminals.	High
<b>15</b>	Jog frequency <sup>1</sup>	The frequency value from (P113) can also be set directly using the HIGHER/LOWER buttons with a controller, Simple Box or Parameter Box and stored in (P113) using the OK button. If the device is operating with inching frequency, any bus actuation that may be active is deactivated.	High
<b>16</b>	Motor potentiometer	Same as setting <b>09</b> but the frequency is not maintained below the minimum frequency P104 and above the maximum frequency P105.	Low
<b>17</b> <sup>5</sup>	ParaSet Switching 2 <i>"Parameter set changeover 2"</i>	Selection of active parameter set 1...4 - second bit.	High
<b>18</b> <sup>2</sup>	Watchdog	Input must see a high flank cyclically (P460), otherwise error E012 will cause a shutdown. Function starts with the 1st high flank.	0→1 flank
<b>19</b>	Setpoint 1 on/off	<b>SK 2x0E:</b> Analog input switch-on and switch-off 1/2 (high = ON) <u>of the variable frequency drive</u>	High
<b>20</b>	Setpoint 2 on/off	<b>SK 2x5E:</b> Analog input switch-on and switch-off 1/2 (high = ON) <u>of the first I/O extension</u> . The Low signal sets the analog input to 0% which does not lead to shutdown when the minimum frequency (P104) > than the absolute minimum frequency (P505).	High



Value	Function	Description	Signal	
21	... 25 reserved for POSICON	→ <a href="#">BU0210</a>		
26	Analog fct. Dig.2+3 ("0-10V")	These functions can only be used for the digital inputs 2 (P420 [-02]) and 3 (P420 [-03]) and not with SK 2x0E size IV!	Pulses that are proportional to an analog signal can be evaluated with this setting via <b>DIN 2</b> and <b>DIN 3</b> . The function of this signal is determined in parameter P400 [-06] or [-07]. The conversion of 0-10 V to pulses can be carried out via customer unit SK CU/TU4-24V-... An analog input and a pulse output (ADC) are available with this module. In setting { 28 }, reversal of the direction of rotation takes place with an analog value of <5 V. (please see chapter 3.2.4 "Potentiometer adapter, SK CU4-POT")	
27	A.fct. 2-10V Dig.2+3			Pulses ≈ 1.6- 16 kHz
28	A.fct. 5-10V Dig.2+3			
29	Enable SK SSX-box	The release signal is provided by the <i>Simple Setpoint Box</i> (setpoint unit) SK SSX-3A, whereby the unit must be operated in <b>IO-S</b> mode. → <a href="#">BU0040</a>	High	
30	Inhibit PID	Switching the PID controller/process controller function on and off (high = ON)	High	
31 <sup>2</sup>	Inhibit turn right	Blocks the >Enable right/left< via a digital input or bus actuation. Does not depend on the actual direction of rotation of the motor (e.g. following negated setpoint).	Low	
32 <sup>2</sup>	Inhibit turn left		Low	
33	... 41 reserved			
42	0-track HTL-Sync DI1	Activates the evaluation of the zero track of a rotary encoder. Synchronization to zero pulse after every enable command.	High	
43	0-pulse HTL enc. DI1	Activates the evaluation of the zero track of a rotary encoder. Synchronization to zero pulse after first enabling after "power on".	High	
44	3-Wire Direction "3-wire control direction change" (normally open button)		0→1 flank	
45	3-W-Ctrl. Start-Right "3-wire control start right" (normally open button)	This control function provides an alternative to enable R/L (01/02), for which a maintained signal is required.	0→1 flank	
46	3-W-Ctrl.Start-Left "3-wire control start left" (normally open button)	Only a momentary signal is required here to trigger the function. The VFD can therefore be controlled entirely with pushbuttons.	0→1 flank	
49	3-Wire-Ctrl.Stop "3-wire control stop" (normally closed button)		1→0 flank	
47	Motorpot. Freq. + "Motor potentiometer frequency +"	In combination with enable R/L the output frequency can be continuously varied. To save a current value in P113, both inputs must be at a High voltage for 0.5 s. This value then applies as the next starting value for the same direction of rotation (Enable R/L) otherwise start at f <sub>MIN</sub> .	High	
48	Motorpot. Freq. - "Motor potentiometer frequency -"		High	
50	Bit 0 fixedfreq.Array	Binary coded digital inputs to generate up to 15 fixed frequencies. (P465: [-01] ... [-15])	High	
51	Bit 1 fixedfreq.Array		High	
52	Bit 2 fixedfreq.Array		High	
53	Bit 3 fixedfreq.Array		High	
55	... 64 reserved for POSICON	→ <a href="#">BU0210</a>		
65 <sup>2</sup>	Brake man/auto rel. "Release brake manually/automatically"	The brake is automatically released by the variable frequency drive (automatic brake control) if this digital input has been set.	High	
66 <sup>2</sup>	Brake man Release "Release brake manually"	The brake is only released if the digital input is set.	High	

Value	Function	Description	Signal
67	Dig. Out man/auto set "Set digital output manually/automatically"	Set digital output 1 manually, or via the function set in (P434)	High
68	Dig.out manual set "Set digital output manually"	Set digital output 1 manually	High
69	Speed meas. with ini. "Speed measurement with initiator"	Simple speed measurement (impulse measurement) with initiator	Pulses
70	Evacuation mode "Activate evacuation run"	This also provides the possibility of operation with a very low DC link voltage (e.g. using batteries). With this function the charging relay is activated and existing monitoring functions are deactivated. <b>CAUTION!</b> There is no overload monitoring! (e.g. lifting gear)	High
71 <sup>3</sup>	Motorpot. F+ and Save "Motor potentiometer function Frequency + with automatic saving"	With this "motor potentiometer function" a setpoint (sum) is set via the digital inputs, and simultaneously stored. With control enabling R/L this is then started up in the correspondingly enabled direction. On change of direction the frequency is retained. Simultaneous activation of the +/- function causes the frequency setpoint value to be set to zero.	High
72 <sup>3</sup>	Motorpot. F- and Save "Motor potentiometer function Frequency - with automatic saving"	The frequency setpoint can also be displayed or set in the operating value display (P001 = 30, "Cur. set value MP-S") or in P718. Any minimum frequency set (P104) is still effective. Other setpoint values, e.g. analog or fixed frequencies, can be added or subtracted. The adjustment of the frequency setpoint value is performed with the ramps from P102/103.	High
73 <sup>2</sup>	Inhibit right + quick "Disable clockwise rotation + fast stop"	Same as setting 31 but coupled to the "quick stop" function.	Low
74 <sup>2</sup>	Inhibit left + quick "Disable counterclockwise rotation + fast stop"	Same as setting 32 but coupled to the "quick stop" function.	Low
75	DO 2 man/auto set "Set digital output manually/automatically"	2 Same as function 67 but for digital output 2 (only SK 2x0E)	High
76	DO 2 man. set "Set digital output 2 manually"	Same as function 68 but for digital output 2 (only SK 2x0E)	High
77	... 78 reserved for POSICON	→ <a href="#">BU0210</a>	
79	Rotorpos. Ident	Exact knowledge of the rotor position is essential for PMSM operation. Rotor position identification is performed if the following conditions are met: <ul style="list-style-type: none"> <li>The variable frequency drive is in the status "ready to switch-on",</li> <li>The rotor position is not known (see P434, P481, function "28"),</li> <li>Function "2" is selected in P336.</li> </ul>	1→0 flank
80	PLC stop	The program execution of the integrated PLC is stopped for as long as the signal is present.	High
1	If no digital input has been parameterized to "Enable right" or "Enable left" and with devices from SK 22xE, all AS-i relevant BUS-In bits (P480) are deactivated and DIP switches S1 "3- 5" are in the factory setting, the actuation of a fixed frequency or the jog frequency leads to the enabling of the variable frequency drive. The rotation field direction depends on the sign of the setpoint.		
2	Also effective for BUS control (e.g. RS232, RS485, CANopen, AS-Interface, ...)		

Value	Function	Description	Signal															
3		With SK 2x5 devices the variable frequency drive control unit must be supplied with power for a further 5 minutes after the last change to the motor potentiometer in order to permanently save the data.																
4		Function cannot be selected via BUS IO In Bits																
5		<p>The operating parameter set is selected via appropriately parameterized digital inputs or BUS actuation. Switching can take place during operation (online). Binary coding takes place in accordance with the adjacent sample.</p> <p>When enabled via the keyboard (Simple Box, Control Unit, Potentiometer Unit or Parameter Box), the operating parameter set will match the setting in P100.</p>																
			<table border="1"> <thead> <tr> <th>Setting</th> <th>Digital input function [8]</th> <th>Digital input function [17]</th> </tr> </thead> <tbody> <tr> <td>0 = Parameter set 1</td> <td>LOW</td> <td>LOW</td> </tr> <tr> <td>1 = Parameter set 2</td> <td>HIGH</td> <td>LOW</td> </tr> <tr> <td>2 = Parameter set 3</td> <td>LOW</td> <td>HIGH</td> </tr> <tr> <td>3 = Parameter set 4</td> <td>HIGH</td> <td>HIGH</td> </tr> </tbody> </table>	Setting	Digital input function [8]	Digital input function [17]	0 = Parameter set 1	LOW	LOW	1 = Parameter set 2	HIGH	LOW	2 = Parameter set 3	LOW	HIGH	3 = Parameter set 4	HIGH	HIGH
Setting	Digital input function [8]	Digital input function [17]																
0 = Parameter set 1	LOW	LOW																
1 = Parameter set 2	HIGH	LOW																
2 = Parameter set 3	LOW	HIGH																
3 = Parameter set 4	HIGH	HIGH																

<b>P426</b>	<b>Quick stop time</b> ( <i>quick stop time</i> )	<b>S</b>	<b>P</b>
0 ... 320.00 s { 0.10 }	<p>Setting of the stop time for the fast stop function which can be triggered either via a digital input, the bus control, the keyboard or automatically in case of a fault.</p> <p>Emergency stop time is the time for the linear frequency decrease from the set maximum frequency (P105) to 0 Hz. If an actual setpoint &lt;100% is being used, the emergency stop time is reduced correspondingly.</p>		
<b>P427</b>	<b>Quick stop on Error</b> ( <i>Quick stop on error</i> )	<b>S</b>	
0 ... 2 { 0 }	<p>Activation of automatic emergency stop following error</p> <p><b>0 = Switched off:</b> Automatic emergency stop following error is deactivated</p> <p><b>1 = reserved</b></p> <p><b>2 = Switched on:</b> Automatic emergency stop following fault</p> <p>A quick stop can be triggered by error <b>E2.x</b>, <b>E7.0</b>, <b>E10.x</b>, <b>E12.8</b>, <b>E12.9</b> and <b>E19.0</b>.</p>		
<b>P428</b>	<b>Automatic starting</b> ( <i>automatic start</i> )	<b>S</b>	<b>P</b>
0 ... 1 { 0 }	<p>In the standard setting (P428 = <b>0</b> → <b>Off</b>) the VFD requires a flank to enable (signal change from "low → high") at the relevant digital input.</p> <p>In the setting <b>On</b> → <b>1</b> the VFD reacts to a high level. This function is only possible if the VFD is controlled using the digital inputs. (see P509=0/1)</p> <p>In some cases, the VFD must start up directly when line power is switched on. For this P428 = <b>1</b> → <b>On</b> can be set. If the enable signal is permanently switched on, or equipped with a cable jumper, the VFD starts up immediately.</p> <p><b>NOTE:</b> (P428) not "ON" if (P506) = 6, <b>Danger!</b> (See note on (P506))</p> <p><b>NOTE:</b> The "Automatic Start" function can only be used if a digital input of the <u>variable frequency drive</u> (DIN 1 ... DIN 4) is parameterized to the function "Enable Right" or "Enable Left" and this input is permanently set to "high". The digital inputs of the technology modules (e.g.: SK CU4 - IOE) do not support this "Automatic Start" function!</p> <p><b>NOTE:</b> The "Automatic Start" function can only be activated if the variable frequency drive has been parameterized to local control ((P509) setting { 0 } or { 1 }).</p>		

P434 [-01] [-02]	<b>Digital out function</b> <i>(Digital output function)</i>		
0 ... 40 { 7 }	<p><b>[-01] = Digital output 1</b>, Digital output 1 of the variable frequency drive</p> <p><b>[-02] = Digital output 2</b>, Digital output 2 of the variable frequency drive (only SK 2x0E)</p> <p>Settings 3 to 5 and 11 operate with a 10% hysteresis, i.e. the output delivers (Funct. 11 does not deliver) when the limit value 24 V is reached and switches this off again when a 10% lower value is undershot (Funct. 11 on again).</p> <p>This behavior can be inverted with a negative value in P435.</p>		
		Setting/Function	Output ... with limit or function (see also P435)
	<b>0 = No function</b>		Low
	<b>1 = External brake</b> , to control an external 24 V brake relay (max. 20 mA). The output switches at a programmed absolute minimum frequency (P505). For typical brakes a setpoint delay of 0.2-0.3 s should be programmed (see also P107/P114). SK 2x0E (Size 4) and SK 2x5E: A typical motor brake (105-180-205 V) can be connected directly via control terminals 79 MB+/80 MB- (chapter 2.4.2.4).		Low
	<b>2 = Inverter is working</b> , the output indicates voltage at the VFD output (U - V - W).		High
	<b>3 = Current limit</b> , based on the setting of the nominal current (P203). This value can be adjusted via scaling (P435).		High
	<b>4 = Torque current limit</b> , based on motor data settings in P203 and P206. Signals a corresponding torque load on the motor. This value can be adjusted via scaling (P435).		High
	<b>5 = Frequency limit</b> , based on nominal frequency setting in P201. This value can be adjusted via scaling (P435).		High
	<b>6 = Level with setpoint</b> , indicates that the VFD has completed the frequency increase or decrease. Setpoint frequency = actual frequency! From a difference of 1 Hz → <i>Setpoint value not achieved – signal low</i> .		High
	<b>7 = Fault</b> , general fault message, error is active or not yet acknowledged. → <i>Fault - low (ready - high)</i>		Low
	<b>8 = Warning</b> , general warning, a limit was reached that could lead to a later shutdown of the VFD.		Low
	<b>9 = Overcurrent warning</b> : At least 130% of the VFD nominal current was supplied for 30 seconds.		Low
	<b>10 = Mot. overtemp. warning</b> , " <i>Motor overtemperature warning</i> ": The motor temperature is evaluated. → Motor is too hot. The warning is given immediately, overheating switch-off after 2 seconds.		Low
	<b>11 = Torque current limit</b> , " <i>Torque current limit/current limit active warning</i> ": The limiting value in P112 or P536 has been reached. A negative value in P435 inverts the reaction. Hysteresis = 10%.		Low
	<b>12 = Value of P541</b> , " <i>Value of P541 - external control</i> ", the output can be controlled with parameter P541 (Bit 0) independent of the actual operating status of the VFD.		High
	<b>13 = Torq.curr. limit gen</b> , " <i>Drive torque current limit active</i> ": Limit value in P112 has been reached in the generator range. Hysteresis = 10%		High
	<b>16 = Comparison val. AIN1</b> , <b>SK 2x0E:</b> Setpoint AIN1 of the VFD is compared with the value in (P435[-01 or -02]). <b>SK 2x5E:</b> Setpoint AIN1 of 1st I/O extension is compared with value in (P435[-01])		High

<b>17 = Comparison val. AIN2, SK 2x0E:</b> Setpoint AIN2 of the VFD is compared with the value in (P435[-01 or -02]). <b>SK 2x5E:</b> Setpoint AIN2 of 1st I/O extension is compared with value in (P435[-01])	High
<b>18 = Inverter ready:</b> The VFD is ready for operation. After being enabled it delivers an output signal.	High
<b>19 = ... 27 reserved</b>	POSITION functions see BU 0210
<b>28 = Rotor pos. PMSM ok</b> The PMSM rotor position is known.	High
<b>29 = Reserved</b>	
<b>30 = Status dig in 1</b>	High
<b>31 = Status dig in 2</b>	High
<b>32 = Status dig in 3</b>	High
<b>33 = Status dig in 4</b>	High
<b>38 = Value Bus Setpoint</b>	High
<b>39 = STO inactive</b>	High
<b>40 = Output via PLC:</b> The output is set by the integrated PLC	High

**i Information**

**"low" active settings/functions**

If the variable frequency drive is not in operation, i.e. no line or control voltage is connected, all outputs have no function ("low"). This means that the following must be taken into account when using settings or functions that are "low" active (e.g setting **7** → **Fault**):

Evaluation of the output signal of the device, e.g. by a PLC must be compared with the basic readiness for operation of the variable frequency drive.

<b>P435</b>	<b>[-01] Dig. out scaling</b>			
	<b>[-02] (digital output standardization)</b>			
-400 ... 400 % { 100 }	<b>[-01] = Digital output 1</b> , Digital output 1 of the variable frequency drive			
	<b>[-02] = Digital output 2</b> , Digital output 2 of the variable frequency drive SK 2x0E			
Adjustment of the limits of the output function. For a negative value, the output function will be output negative.				
Reference to the following values:				
Current limit (3) = x [%] · P203 >Rated motor current<				
Torque current limit (4) = x [%] · P203 · P206 (calculated rated motor torque)				
Frequency limit (5) = x [%] · P201 >Rated motor frequency<				

<b>P436</b>	<b>[-01] Dig. out. hysteresis</b> <b>[-02] (digital output hysteresis)</b>		<b>S</b>	
1 ... 100 % { 10 }	<b>[-01] = Digital output 1</b> , Digital output 1 of the variable frequency drive <b>[-02] = Digital output 2</b> , Digital output 2 of the variable frequency drive SK 2x0E Difference between switch-on and switch-off point to prevent oscillation of the output signal.			
<b>P460</b>	<b>Watchdog time</b> <i>(time watchdog)</i>		<b>S</b>	
-250.0 ... 250.0 s { 10.0 }	<b>0.1 ... 250.0</b> = The time interval between the expected watchdog signals (programmable function of the digital inputs P420...). motor PTC") the variable frequency drive is to immediately reduce the speed to a specific speed (e.g. by means of an active fixed frequency). If this time interval elapses without a pulse being registered, switch-off and error message E012 are actuated. <b>0.0 = customer error:</b> As soon as a high-low flank or a low signal is detected at a digital input (function 18) the VFD switches off with error message E012. <b>-250.0 ... -0.1 = rotor motion watchdog:</b> Rotor motion watchdog is active in this setting. The time is defined by the amount of the set value. There is no watchdog message when the device is switched off. After each enable, a pulse must first come before the watchdog is activated.			
<b>P464</b>	<b>Fixed frequency mode</b> <i>(fixed frequency mode)</i>		<b>S</b>	
0 ... 1 { 0 }	This parameter determines the form in which fixed frequencies are to be processed. <b>0 = Add to main setvalue:</b> Fixed frequencies and the fixed frequency array behave additively to each other. That means they are added to each other or to an analog setpoint in the limits assigned as per P104 and P105. <b>1 = Equal main setvalue:</b> Fixed frequencies are not added, neither together nor to main analog setpoints. If for example, a fixed frequency is switched to an existing analog setpoint, the analog setpoint will no longer be considered. Programmed frequency addition or subtraction with an analog input value or a bus setpoint is still possible and valid, as is the addition to the setpoint of a motor potentiometer function (function of digital inputs: 71/72). If several fixed frequencies are selected simultaneously, the frequency with the highest value has priority (e.g.: $\underline{20} > 10$ or $\underline{20} > -30$ ). <b>Note:</b> The highest active fixed frequency is added to the setpoint of the motor potentiometer if functions 71 or 72 are selected for 2 digital inputs.			

<b>P465</b>	[-01] ... [-15]	<b>fixed frequency Array</b> <i>(fixed frequency/frequency array)</i>			
<p>-400.0 ... 400.0 Hz          { [-01] = 5.0 }          { [-02] = 10.0 }          { [-03] = 20.0 }          { [-04] = 35.0 }          { [-05] = 50.0 }          { [-06] = 70.0 }          { [-07] = 100.0 }          { [-08] = 0.0 }          { [-09] = -5.0 }          { [-10] = -10.0 }          { [-11] = -20.0 }          { [-12] = -35.0 }          { [-13] = -50.0 }          { [-14] = -70.0 }          { [-15] = -100.0 }</p>	<p>In the array levels, up to 15 different fixed frequencies can be set, which in turn can be encoded for the functions 50...54 in binary code for the digital inputs.</p> <hr/> <p><b>[-01]</b> = Fixed frequency 1/array 1  <b>[-02]</b> = Fixed frequency 2/array 2  <b>[-03]</b> = Fixed frequency 3/array 3  <b>[-04]</b> = Fixed frequency 4/array 4  <b>[-05]</b> = Fixed frequency array 5  <b>[-06]</b> = Fixed frequency array 6  <b>[-07]</b> = Fixed frequency array 7  <b>[-08]</b> = Fixed frequency array 8</p>	<p><b>[-09]</b> = Fixed frequency array 9  <b>[-10]</b> = Fixed frequency array 10  <b>[-11]</b> = Fixed frequency array 11  <b>[-12]</b> = Fixed frequency array 12  <b>[-13]</b> = Fixed frequency array 13  <b>[-14]</b> = Fixed frequency array 14  <b>[-15]</b> = Fixed frequency array 15</p>			
<b>P466</b>		<b>Min. freq. proc.ctrl.</b> <i>(minimum frequency process controller)</i>		<b>S</b>	<b>P</b>
<p>0.0 ... 400.0 Hz          { 0.0 }</p>	<p>With the aid of the minimum frequency process controller the control ratio can also be kept to a minimum ratio, even with a master value of "zero", in order to enable adjustment of the compensator. Further details in P400 and (chapter 8.2).</p>				
<b>P475</b>	[-01] ... [-04]	<b>delay on/off switch</b> <i>(digital function switch on/off delay)</i>		<b>S</b>	
<p>-30,000 ... 30,000 s          { 0,000 }</p>	<p>Adjustable switch-on/off delay for digital inputs and digital functions of the analog inputs. Use as a switch-on filter or simple process control is possible.</p> <p><b>[-01]</b> = Digital input 1  <b>[-02]</b> = Digital input 2  <b>[-03]</b> = Digital input 3  <b>[-04]</b> = Digital input 4</p>	<p><b>Positive values</b> = switch-on delayed  <b>Negative values</b> = switch-off delayed</p>			



<b>P480</b>	<b>[-01]</b> ... <b>[-12]</b>	<b>Function BusIO In Bits</b> <i>(Function Bus I/O In Bits)</i>		
0 ... 80 { [-01] = 01 } { [-02] = 02 } { [-03] = 05 } { [-04] = 12 } { [-05...-12] = 00 }	<p>The Bus I/O In Bits are perceived as digital inputs. They can be set to the same functions (P420).          With devices with an integrated AS interface, the I/O bits can be used by the interface itself (bit 0 ... 3) or in combination with I/O extensions (SK xU4-IOE) (bits 4 ... 7 and bits 0 ... 3). <i>The priority in AS-i devices is AS-i. In this case, BUS IO BITS 1 ... 4 cannot be used by the 2nd IO extension.</i></p> <p> <b>[-01] = Bus/AS-i Dig In1</b> (Bus IO In Bit 0 + AS-i 1 or DI 1 of the <b>second</b> SK xU4-IOE (DigIn 09))  <b>[-02] = Bus/AS-i Dig In2</b> (Bus IO In Bit 1 + AS-i 2 or DI 2 of the <b>second</b> SK xU4-IOE (DigIn 10))  <b>[-03] = Bus/AS-i Dig In3</b> (Bus IO In Bit 2 + AS-i 3 or DI 3 of the <b>second</b> SK xU4-IOE (DigIn 11))  <b>[-04] = Bus/AS-i Dig In4</b> (Bus IO In Bit 3 + AS-i 4 or DI 4 of the <b>second</b> SK xU4-IOE (DigIn 12))  <b>[-05] = Bus/IOE Dig In1</b> (Bus IO In Bit 4 + DI 1 of the <b>first</b> SK xU4-IOE (DigIn 05))  <b>[-06] = Bus/IOE Dig In2</b> (Bus IO In Bit 5 + DI 2 of the <b>first</b> SK xU4-IOE (DigIn 06))  <b>[-07] = Bus/IOE Dig In3</b> (Bus IO In Bit 6 + DI 3 of the <b>first</b> SK xU4-IOE (DigIn 07))  <b>[-08] = Bus/IOE Dig In4</b> (Bus IO In Bit 7 + DI 4 of the <b>first</b> SK xU4-IOE (DigIn 08))  <b>[-09] = Flag 1</b> <sup>1)</sup>  <b>[-10] = Flag 2</b> <sup>1)</sup>  <b>[-11] = Bit 8 BUS controlword</b>  <b>[-12] = Bit 9 BUS controlword</b> </p> <p>The possible functions for the bus In bits can be found in the table of functions for the digital inputs in parameter (P420). Functions {14} "Remote control" and {29} "Enable Setpoint Box" are not possible.</p>			

1) The flag function is only possible with control via control terminals.

<b>P481</b>	<b>[-01]</b> ... <b>[-10]</b>	<b>Funct. BusIO Out Bits</b> <i>(Function Bus I/O Out Bits)</i>		
0 ... 40 { [-01] = 18 } { [-02] = 08 } { [-03] = 30 } { [-04] = 31 } { [-05...-10] = 00 }	<p>The bus I/O Out bits are perceived as multi-function relay outputs. They can be set to the same functions (P434).          With devices with in integrated AS interface, the I/O bits can be used by the interface itself (bit 0 ... 3) or in combination with I/O extensions (SK xU4-IOE) (bits 4 ... 5 and flags 1 ... 2).</p> <p> <b>[-01] = Bus / AS-i Dig Out1</b> (Bus IO Out Bit 0 + AS-i 1)  <b>[-02] = Bus / AS-i Dig Out2</b> (Bus IO Out Bit 1 + AS-i 2)  <b>[-03] = Bus / AS-i Dig Out3</b> (Bus IO Out Bit 2 + AS-i 3)  <b>[-04] = Bus / AS-i Dig Out4</b> (Bus IO Out Bit 3 + AS-i 4)  <b>[-05] = Bus / IOE Dig Out1</b> (Bus IO Out Bit 4 + DO 1 of the <b>first</b> SK xU4-IOE (DigOut 02))  <b>[-06] = Bus / IOE Dig Out2</b> (Bus IO Out Bit 5 + DO 2 of the <b>first</b> SK xU4-IOE (DigOut 03))  <b>[-07] = Bus / 2nd IOE Dig Out1</b> (Flag 1 <sup>1)</sup> + DO 1 of the <b>second</b> SK xU4-IOE (DigOut 04))  <b>[-08] = Bus / 2nd IOE Dig Out2</b> (Flag 2 <sup>1)</sup> + DO 2 of the <b>second</b> SK xU4-IOE (DigOut 05))  <b>[-09] = BUS statusword Bit 10</b>  <b>[-10] = BUS statusword Bit 13</b> </p> <p>The possible functions for the Bus Out Bits can be found in the table of functions for the digital outputs (P434).</p>			

1) The flag function is only possible with control via control terminals.

**P480 ... P481 Using Marker**

With the aid of the two flags it is possible to define simple, logical sequences of functions. To do this, the "triggers" for a function (e.g. a motor PTC overtemperature warning) are defined in parameter (P481) in arrays [-09] - "Flag 1" and [-10] - "Flag 2".

In arrays [-11] and [-12] of parameter P480, the function which the variable frequency drive is to perform if the "trigger" is active is assigned in arrays [-11] and [-12] of parameter P480. I.e. parameter P480 determines the response of the variable frequency drive.

*Example:*

In an application, the variable frequency drive is to reduce the actual speed immediately (e.g. with an active fixed frequency) if the motor is in the overtemperature range ("Motor overtemp.PTC"). This is to be implemented by "Deactivation of analog input 1" via which in this example, the actual setpoint is normally set.

This is used to reduce the load on the motor, so that the temperature can stabilize or the drive unit reduces speed to a defined value before a shut-down due to error occurs.

Step	Description	Function
1	Determine the trigger, Set flag 1 to the "Motor overtemperature warning" function	P481 [-07] → Function "12"
2	Specify the reaction, Set flag 1 to the function "Setpoint 1 On/Off"	P480 [-09] → Function "19"

Depending on the function which is selected in (P481) the function may need to be inverted by modification of the standardization (P482).

<b>P482</b>	<b>[ -01 ]</b>	<b>Standard BusIO Out Bits</b>		<b>S</b>	
	<b>[ ... ]</b>	<i>(standardization of Bus I/O Out Bits)</i>			
	<b>[ -10 ]</b>				

-400 ... 400 %  
{ all 100 }

Adjustment of the limit values of the bus Out bits. For a negative value, the output function will be output negative.

Once the limit value is reached and positive values are delivered, the output produces a High signal, for negative setting values a Low signal.

**[ -01 ] = Bus / AS-i Dig Out1** (Bus IO Out Bit 0 + AS-i 1)  
**[ -02 ] = Bus / AS-i Dig Out2** (Bus IO Out Bit 1 + AS-i 2)  
**[ -03 ] = Bus / AS-i Dig Out3** (Bus IO Out Bit 2 + AS-i 3)  
**[ -04 ] = Bus / AS-i Dig Out4** (Bus IO Out Bit 3 + AS-i 4)  
**[ -05 ] = Bus / IOE Dig Out1** (Bus IO Out Bit 4 + DO 1 of the **first** SK xU4-IOE (DigOut 02))  
**[ -06 ] = Bus / IOE Dig Out2** (Bus IO Out Bit 5 + DO 2 of the **first** SK xU4-IOE (DigOut 03))  
**[ -07 ] = Bus/ 2nd IOE Dig Out1** (Flag 1 + DO 1 of the **second** SK xU4-IOE (DigOut 04))  
**[ -08 ] = Bus / 2nd IOE Dig Out2** (Flag 2 + DO 2 of the **second** SK xU4-IOE (DigOut 05))  
**[ -09 ] = BUS statusword Bit 10**  
**[ -10 ] = BUS statusword Bit 13**

<b>P483</b>	<b>[ -01 ]</b>	<b>Hyst. BusIO Out Bits</b>		<b>S</b>	
	<b>[ ... ]</b>	<i>(Hysteresis Bus I/O Out Bits)</i>			
	<b>[ -10 ]</b>				

1 ... 100 % Difference between switch-on and switch-off point to prevent oscillation of the output signal.

{ all 10 }

<b>[-01] = Bus / AS-i Dig Out1</b>	(Bus IO Out Bit 0 + AS-i 1)
<b>[-02] = Bus / AS-i Dig Out2</b>	(Bus IO Out Bit 1 + AS-i 2)
<b>[-03] = Bus / AS-i Dig Out3</b>	(Bus IO Out Bit 2 + AS-i 3)
<b>[-04] = Bus / AS-i Dig Out4</b>	(Bus IO Out Bit 3 + AS-i 4)
<b>[-05] = Bus / IOE Dig Out1</b>	(Bus IO Out Bit 4 + DO 1 of the <b>first</b> SK xU4-IOE (DigOut 02))
<b>[-06] = Bus / IOE Dig Out2</b>	(Bus IO Out Bit 5 + DO 2 of the <b>first</b> SK xU4-IOE (DigOut 03))
<b>[-07] = Bus/ 2nd IOE Dig Out1</b>	(Flag 1 + DO 1 of the <b>second</b> SK xU4-IOE (DigOut 04))
<b>[-08] = Bus / 2nd IOE Dig Out2</b>	(Flag 2 + DO 2 of the <b>second</b> SK xU4-IOE (DigOut 05))
<b>[-09] = BUS statusword Bit 10</b>	
<b>[-10] = BUS statusword Bit 13</b>	

---

**NOTE:** Details for the use of the relevant bus systems can be found in the relevant supplementary bus manual.

---

### 5.2.6 Additional parameters

Parameter {factory setting}	Setting value/description/note		Supervisor	Parameter set
<b>P501</b>	<b>[-01] Inverter name</b> ... <b>[-20]</b> <i>(inverter name)</i>			

A...Z (char)  
{ 0 }

Free input of a designation (name) for the device (max. 20 characters). The variable frequency drive can be uniquely identified with this when working with NORD CON - software or within a network.

<b>P502</b>	<b>[-01] Value Masterfunction</b> ... <b>[-03]</b> <i>(Master function value)</i>		<b>S</b>	<b>P</b>
-------------	--	--	----------	----------

0 ... 57  
{ all 0 }

Selection of up to 3 master values of a master for output to a bus system (see P503). The assignment of these master values to the slave is carried out via (P546). Definition of frequencies: (📖 Section 8.10 "Definition of setpoint and actual value processing (frequencies)")

**[-01] = Master value 1**
**[-02] = Master value 2**
**[-03] = Master value 3**

Selection of possible setting values for master values:

- |   |  |
|---|--|
| <p><b>0 =</b> Off</p> <p><b>1 =</b> Actual frequency</p> <p><b>2 =</b> Actual speed</p> <p><b>3 =</b> Current</p> <p><b>4 =</b> Torque current</p> <p><b>5 =</b> State digital-IO</p> <p><b>6 =</b> ... 7 reserved, Posicon <a href="#">BU0210</a></p> <p><b>8 =</b> Setpoint frequency</p> <p><b>9 =</b> Error code</p> <p><b>10 =</b> ... 11 reserved, Posicon <a href="#">BU0210</a></p> <p><b>12 =</b> Bus IO Out Bits 0-7</p> <p><b>13 =</b> ... 16 reserved, Posicon <a href="#">BU0210</a></p> | <p><b>17 =</b> Value Analog In 1<br/><b>SK2x0E:</b> Analog input 1 (P400[-01]),<br/><b>SK2x5E:</b> AIN1 of the first I/O extension<br/>SK xU4-IOE (P400 [-03]))</p> <p><b>18 =</b> Value Analog In 2<br/><b>SK2x0E:</b> Analog input 2 (P400[-02]),<br/><b>SK2x5E:</b> AIN2 of the first I/O extension<br/>SK xU4-IOE (P400 [-04]))</p> <p><b>19 =</b> Setpoint freq. Master value, "<i>Setpoint frequency master value</i>"</p> <p><b>20 =</b> Set Freq. After Ramp,<br/>"<i>Setpoint frequency from ramp master value</i>"</p> <p><b>21 =</b> Actual freq. without slip Master value<br/>"<i>Actual frequency without master value slip</i>"</p> <p><b>22 =</b> Speed encoder</p> <p><b>23 =</b> Act. Freq. with slip <i>(SW V1.3 and above)</i><br/>"<i>Actual frequency with slip</i>"</p> <p><b>24 =</b> Leas act. freq. w. slip <i>(from SW V1.3)</i><br/>"<i>Actual frequency master value with slip</i>"</p> <p><b>53 =</b> Actual value 1 PLC</p> <p><b>54 =</b> Actual value 2 PLC</p> <p><b>55 =</b> Actual value 3 PLC</p> <p><b>56 =</b> Actual value 4 PLC</p> <p><b>57 =</b> Actual value 5 PLC</p> |
|---|--|

**NOTE:** Details with regard to target and actual value processing: (📖 Section 8.9 "Standardization of setpoint/target values").

<b>P503</b>	<b>Leading function output</b> <i>(master function output)</i>		<b>S</b>	
0 ... 3 { 0 }	<p>For master-slave applications this parameter specifies on which bus system the master transmits the control word and the master values (P502) for the slave. On the slave, parameters (P509), (P510), (P546) define the source from which the slave obtains the control word and the master values from the master and how these are to be processed by the slave.</p> <p>Specification of communication mode on the system bus for Parameter Box and NORDCON.</p> <div style="display: flex; justify-content: space-between;"> <div style="width: 48%;"> <p><b>0 = Off</b> <b>No</b> control word and master value, <b>If no exclusive BUS option</b> (e.g. SK xU4-IOE) is connected to the system bus, only the device immediately connected to the Parameter Box/NORDCON is visible.</p> <p><b>1 = CANopen (systembus)</b> <b>Control words</b> and master values are transferred to the system bus <b>If no exclusive BUS option</b> (e.g. SK xU4-IOE) is connected to the system bus, only the device immediately connected to the Parameter Box/NORDCON is visible.</p> </div> <div style="width: 48%;"> <p><b>2 = Systembus active</b> <b>No</b> control word and master value output, <b>All</b> VFDs connected to the system bus are visible in the Parameter Box or NORDCON even if no bus option is connected. Prerequisite: all VFDs must be set to this mode.</p> <p><b>3 = CANopen + systembus active</b> <b>Control word</b> and master values are transferred to the system bus <b>All</b> VFDs connected to the system bus are visible in the Parameter Box or NORDCON even if no bus option is connected. Prerequisite: all other VFDs must be set to mode { 2 } "System bus active"</p> </div> </div>			
<b>P504</b>	<b>Pulse frequency</b> <i>(pulse frequency)</i>		<b>S</b>	
3.0 ... 16.1 kHz { 6.0 }	<p>The internal pulse frequency for controlling the power unit can be changed with this parameter. A higher setting reduces motor noise, but leads to increased EMC emissions and reduction of the possible motor nominal torque.</p> <p><b>NOTE:</b> The best possible degree of interference suppression for the device is adhered to by using the default value and taking the wiring directives into consideration.</p> <p><b>NOTE:</b> Raising the pulse frequency leads to a reduction of the possible output current, depending on the time (<math>I^2t</math> curve). When the temperature warning limit (C001) is reached, the pulse frequency is gradually lowered to the default value. If the VFD temperature drops by a sufficient amount, the pulse frequency is increased to the original value.</p> <p><b>NOTE:</b> <b>Setting 16.1:</b> The automatic adaptation of the pulse frequency is activated with this setting. When doing this, the variable frequency drive permanently determines the maximum possible pulse frequency taking different influential factors into consideration such as the heat sink temperature or an overcurrent warning.</p> <p><b>NOTE:</b> In case of overload of the variable frequency drive, the pulse frequency is automatically reduced depending on the actual overload level to avoid overcurrent shutdown (see also <b>P537</b>).</p> <p>With use of a sinus filter, a constant pulse frequency is required at any time as otherwise "Module error" (<b>E4.0</b>) shutdowns may be triggered.</p> <p>The following settings are used to select the required, constant pulse frequencies.</p> <p><b>Setting 16.2:</b> 6 kHz <b>Setting 16.3:</b> 8 kHz</p> <p>Please note: With these settings, short circuits at the output which occur before enabling may possibly not be detected correctly.</p>			

**NOTE:** *Setting 16.4:* Automatic load adjustment  
 The pulse frequency is automatically adjusted between a minimum value (highest load reserve) and a maximum value (lowest load reserve) depending on the load.  
 During an acceleration phase and if high power is required ( $\geq$  rated power) the minimum value is set. With constant speed and a power requirement  $\leq$  80% to the rated power, the high pulse frequency is set.

<b>P505</b>	<b>Abs. minimum frequency</b> <i>(absolute minimum frequency)</i>		<b>S</b>	<b>P</b>
0.0 ... 10.0 Hz { 2.0 }	<p>Specifies the frequency value that cannot be undershot by the VFD. If the setpoint becomes smaller than the absolute minimum frequency, the VFD switches off or changes to 0.0 Hz.</p> <p>At the absolute minimum frequency, braking control (P434) and the setpoint delay (P107) are actuated. If a setting value of "zero" is selected, the brake relay does not switch during reversing.</p> <p>When controlling lift equipment without speed feedback, this value should be set to a minimum of 2 Hz. From 2 Hz, the current control of the VFD operates and a connected motor can supply sufficient torque.</p> <p><b>NOTE:</b> Output frequencies &lt; 4.5 Hz lead to current limitation (chapter 8.4.3).</p>			
<b>P506</b>	<b>Automatic acknowledged.</b> <i>(automatic fault acknowledgement)</i>		<b>S</b>	
0 ... 7 { 0 }	<p>In addition to the manual error acknowledgement, an automatic one can also be selected.</p> <p><b>0 = no automatic</b> fault acknowledgement.</p> <p><b>1 ... 5 = number</b> of permissible automatic malfunction acknowledgments within one power-on cycle. After power is switched off and on, the full amount is again available.</p> <p><b>6 = always</b>, a fault message will always be acknowledged automatically if the cause of the error is no longer present.</p> <p><b>7 = quit disable.</b>, acknowledgement is only possible using the OK/ENTER key or by power-off. No acknowledgement is implemented by removing the enable!</p> <p><b>NOTE:</b> If (P428) is parameterized to "ON", parameter (P506) "Automatic fault acknowledgement" must not be parameterized to setting 6 "Always" as otherwise the device or system is endangered due to the possibility of continuous restarting in the case of an active error (e.g. short-circuit to ground/short circuit).</p>			



<b>P512</b>	<b>USS address</b> (USS address)												
0 ... 30 { 0 }	Setting of the VFD bus address for USS communication.												
<b>P513</b>	<b>Telegram time-out</b> (telegram timeout)		<b>S</b>										
-0.1 / 0.0 / 0.1 ... 100.0 s { 0.0 }	<p>If the variable frequency drive is directly controlled via the CAN protocol or via RS485, this communication path can be monitored via parameter (P513). Following receipt of a valid telegram, the next one must arrive within the set period. Otherwise the VFD reports an fault and switches off with the error message E010 &gt;Bus Time Out&lt;.</p> <p>The VFD monitors the system bus communication via parameter (P120). Therefore parameter (P513) must usually be left in the factory setting {0.0}. Parameter (P513) must only be set to {-,.1} if faults detected by the optional module (e.g. communication errors on the field bus level) are not to result in the drive unit being switched off.</p> <p><b>0.0 = Off:</b> Monitoring is <b>switched off</b>.</p> <p><b>-0.1 = No error:</b> Even if the bus module detects an error, this does not cause the variable frequency drive to be switched off.</p> <p><b>0.1 ... = On:</b> Monitoring is activated.</p> <p><b>NOTE:</b> The process data channels for USS, CAN/CANopen and CANopen Broadcast are monitoring independently of each other. The decision concerning which channel to monitor is made by means of the setting in parameters P509 and P510.</p> <p>For example, in this way it is possible to register the interruption of a CAN Broadcast communication, although the VFD is still communicating with a Master via CAN.</p>												
<b>P514</b>	<b>CAN bus baud rate</b> (CAN bus baud rate)		<b>S</b>										
0 ... 7 { 5 }	<p>Setting of the transfer rate (transfer speed) via the system bus interface. All bus participants must have the same baud rate setting.</p> <p><b>Note:</b> Optional modules (SK xU4-...) only operate with a transfer rate of 250 kBaud. Therefore the variable frequency drive must remain at the factory setting (250 kBaud).</p> <table data-bbox="464 1346 1422 1480"> <tr> <td><b>0</b> = 10 kbaud</td> <td><b>3</b> = 100 kbaud</td> <td><b>6</b> = 500 kbaud</td> </tr> <tr> <td><b>1</b> = 20 kbaud</td> <td><b>4</b> = 125 kbaud</td> <td><b>7</b> = 1 Mbaud * (test purposes only)</td> </tr> <tr> <td><b>2</b> = 50 kbaud</td> <td><b>5</b> = <b>250 kbaud</b></td> <td></td> </tr> </table> <p style="text-align: right;">*) Reliable operation cannot be guaranteed</p>				<b>0</b> = 10 kbaud	<b>3</b> = 100 kbaud	<b>6</b> = 500 kbaud	<b>1</b> = 20 kbaud	<b>4</b> = 125 kbaud	<b>7</b> = 1 Mbaud * (test purposes only)	<b>2</b> = 50 kbaud	<b>5</b> = <b>250 kbaud</b>	
<b>0</b> = 10 kbaud	<b>3</b> = 100 kbaud	<b>6</b> = 500 kbaud											
<b>1</b> = 20 kbaud	<b>4</b> = 125 kbaud	<b>7</b> = 1 Mbaud * (test purposes only)											
<b>2</b> = 50 kbaud	<b>5</b> = <b>250 kbaud</b>												



<b>P515</b>	<b>[-01] CAN bus address</b> ... <b>[-03]</b> (CAN address (system bus))		<b>S</b>	
0 ... 255 <sub>dec</sub> { all 32 <sub>dec</sub> } or { all 20 <sub>hex</sub> }	Setting of the systembus address. <b>[-01] = Slave address</b> , Receive address for system bus <b>[-02] = Broadcast slave address</b> , system bus reception address (slave) <b>[-03] = Master address</b> , "Broadcast master address", transmission address for system bus (master)			
<b>NOTE:</b> If up to four VFD are to be linked via the system bus, the addresses must be set as follows VFD 1 = 32, VFD 2 = 34, VFD 3 = 36, VFD 4 = 38.  The system bus addresses should be set via DIP switches (chapter 4.3.2.2).				
<b>P516</b>	<b>Skip frequency 1</b> (skip frequency 1)		<b>S</b>	<b>P</b>
0.0 ... 400.0 Hz { 0.0 }	The output frequency around the frequency value (P517) set here is not shown. This range is transmitted with the set brake and acceleration ramp; it cannot be continuously supplied to the output. Frequencies below the absolute minimum frequency should not be set. <b>0.0</b> = Skip frequency inactive			
<b>P517</b>	<b>Skip frequency area 1</b> (skip frequency range 1)		<b>S</b>	<b>P</b>
0.0 ... 50.0 Hz { 2.0 }	Skip range for the >Skip frequency 1< P516. This frequency value is added and subtracted from the skip frequency. Skip frequency area 1: P516 - P517 ... P516 + P517			
<b>P518</b>	<b>Skip frequency 2</b> (skip frequency 2)		<b>S</b>	<b>P</b>
0.0 ... 400.0 Hz { 0.0 }	The output frequency around the frequency value (P519) set here is not shown. This range is transmitted with the set brake and acceleration ramp; it cannot be continuously supplied to the output. Frequencies below the absolute minimum frequency should not be set. <b>0.0</b> = Skip frequency inactive			
<b>P519</b>	<b>Skip frequency area 2</b> (skip frequency range 2)		<b>S</b>	<b>P</b>
0.0 ... 50.0 Hz { 2.0 }	Skip range for the >Skip frequency 2< P518. This frequency value is added and subtracted from the skip frequency. Skip frequency area 2: P518 - P519 ... P518 + P519			

<b>P520</b>	<b>Flying start</b> <i>(flying start)</i>		<b>S</b>	<b>P</b>
-------------	--	--	----------	----------

0 ... 4  
{ 0 }

This function is required to connect the VFD to already rotating motors, e.g. in fan drives. Motor frequencies >100 Hz are only picked up in speed controlled mode (Servo mode P300 = ON).

- 0 = Switched off**, no flying start.
- 1 = Both directions**, the VFD looks for a speed in both directions.
- 2 = Direction of setpoint**, searches only in the direction of the setpoint value which is present.
- 3 = Both dir. after fault**, same as { 3 } but only after mains failure or fault
- 4 = Setpoint after fault** same as { 2 } but only after mains failure or fault

**NOTE:** For physical reasons, the flying start circuit only operates above 1/10 of the nominal motor frequency (P201), however not below 10 Hz.

	Example 1	Example 2
<b>(P201)</b>	50Hz	200Hz
<b>f=1/10*(P201)</b>	f=5 Hz	f=20Hz
<b>Comparison of f vs. f<sub>min</sub></b> with: f <sub>min</sub> =10 Hz	5 Hz < 10 Hz	20 Hz > 10 Hz
<b>Result f<sub>fly</sub>=</b>	<u>The flying start circuit functions above f<sub>fly</sub>=10 Hz.</u>	<u>The flying start circuit functions above f<sub>fly</sub>=20 Hz.</u>

**NOTE:** *PMSM:* The catch function automatically determines the direction of rotation. The device therefore behaves in an identical way to function 1 with the setting for function 2. The device behaves in an identical way to function 3 with the setting for function 4.

In CFC closed loop operation, the catch circuit can only be executed if the rotor position is known in relation to the incremental encoder. For this purpose, the motor initially cannot rotate when it is switched on for the first time after a "Power On" of the device.

<b>P521</b>	<b>Flying start resolution</b> <i>(flying start resolution)</i>		<b>S</b>	<b>P</b>
-------------	--	--	----------	----------

0.02... 2.50 Hz  
{ 0.05 }

Using this parameter, the flying start circuit search increment size can be adjusted. Values that are too large affect accuracy and causes the VFD to cut out with an overcurrent message. If the values are too small, the search time is greatly extended.

<b>P522</b>	<b>Flying start offset</b> <i>(flying start offset)</i>		<b>S</b>	<b>P</b>
-------------	--	--	----------	----------

-10.0 ... 10.0 Hz  
{ 0.0 }

A frequency value that can be added to the frequency value found, e.g. to remain in the motor range and so avoid the generator range and therefore the chopper range.

<b>P523</b>		<b>Factory setting</b> <i>(factory setting)</i>			
0 ... 3 { 0 }		<p>By selecting the appropriate value and confirming it with the Enter key, the selected parameter range is entered in the factory setting. Once the setting has been made, the value of the parameter automatically returns to 0.</p> <p><b>0 = No change:</b> Does not change the parameterization.</p> <p><b>1 = Load factory setting:</b> The complete parameterization of the VFD reverts to the factory setting. All originally parameterized data are lost.</p> <p><b>2 = Fact.setng.w.out bus</b> All parameters of the variable frequency drive, but <u>not</u> the bus parameters, are reset to the factory setting.</p> <p><b>3 = Fact set w/o motor</b> All parameters of the variable frequency drive, but <u>not</u> the motor data parameters (P201 ... P209, P240 ... P246), are reset to the factory setting.</p> <p>Up to firmware version V 2.2 R0 also the PMSM-relevant parameters (<b>P240 to P246</b>) have been reset. This does no longer apply to the current firmware. The parameter settings of these parameters now also remain unchanged.</p> <p><b>Note:</b> If an external EEPROM ("memory module") is plugged in, then a value of ("Factory setting ...") only affect this. If no "memory module" is present, the set command ("Factory setting ...") is applied to the internal EEPROM</p>			
<b>P525</b>	[-01] ... [-03]	<b>Load control max.</b> <i>(load monitoring, maximum value)</i>		<b>S</b>	<b>P</b>
1 ... 400%/401 { all 401 }		<p>Selection of up to 3 auxiliary values:</p> <p><b>[-01] = Auxiliary value 1      [-02] = Auxiliary value 2      [-03] = Auxiliary value 3</b></p> <hr style="border-top: 1px dashed black;"/> <p>Maximum load torque value.</p> <p>Setting of the upper limit of load monitoring. Up to 3 values can be specified. Prefixes are not taken into account, only the integer values are processed (motor/generator torque, right/left rotation). The array elements [-01], [-02] and [-03] of parameters (P525) ... (P527), or the entries which are made there always belong together.</p> <p><b>401 = OFF</b> Means that the function is switched off. No monitoring is performed. This is also the basic setting for the VFD.</p>			
<b>P526</b>	[-01] ... [-03]	<b>Load control min.</b> <i>(load monitoring, minimum value)</i>		<b>S</b>	<b>P</b>
0 ... 400 % { all 0 }		<p>Selection of up to 3 auxiliary values:</p> <p><b>[-01] = Auxiliary value 1      [-02] = Auxiliary value 2      [-03] = Auxiliary value 3</b></p> <hr style="border-top: 1px dashed black;"/> <p>Minimum load torque.</p> <p>Setting of the lower limit of load monitoring. Up to 3 values can be specified. Prefixes are not taken into account, only the integer values are processed (motor/generator torque, right/left rotation). The array elements [-01], [-02] and [-03] of parameters (P525) ... (P527), or the entries which are made there always belong together.</p> <p><b>0 = OFF</b> Means that the function is switched off. No monitoring is performed. This is also the basic setting for the VFD.</p>			

<b>P527</b>	[ -01 ] ... [ -03 ]	<b>Load control freq.</b> <i>(load monitoring frequency)</i>		<b>S</b>	<b>P</b>
0.0 ... 400.0 Hz { all 25.0 }	<p>Selection of up to 3 auxiliary values:  <b>[ -01 ] = Auxiliary value 1      [ -02 ] = Auxiliary value 2      [ -03 ] = Auxiliary value 3</b></p> <hr/> <p>Auxiliary frequency values            Definition of up to 3 frequency points, which define the monitoring range for load monitoring. The auxiliary frequency values do not need to be entered in order of size. Prefixes are not taken into account, only the integer values are processed (motor/generator torque, right/left rotation). The array elements [ -01 ], [ -02 ] and [ -03 ] of parameters (P525) ... (P527), or the entries which are made there always belong together.</p>				
<b>P528</b>		<b>Load control delay</b> <i>(load monitoring delay)</i>		<b>S</b>	<b>P</b>
0.10 ... 320.00 s { 2.00 }	<p>Parameter (P528) defines the delay time for which an error message ("E12.5") is suppressed on infringement of the defined monitoring range ((P525) ... (P527)). A warning ("C12.5") is triggered after half of this time has elapsed.</p> <p>According to the selected monitoring mode (P529) an error message can also be generally suppressed.</p>				
<b>P529</b>		<b>Mode Load control</b> <i>(load monitoring mode)</i>		<b>S</b>	<b>P</b>
0 ... 3 { 0 }	<p>The reaction of the variable frequency drive to an infringement of the defined monitoring range ((P525) ... (P527)) after the elapse of the delay time (P528) is specified by parameter (P529).</p> <p><b>0 = Fault and warning.</b> After the elapse of the time defined in (P528), an infringement of the monitoring range produces a fault ("E12.5"). A warning ("C12.5") is given after the elapse of half of this time.</p> <p><b>1 = Warning.</b> After the elapse of half of the time defined in (P528) and infringement of the monitoring range produces a warning ("C12.5").</p> <p><b>2 = Fault and warning, constant move, "Error and warning during constant travel",</b> as for setting "0" however monitoring is inactive during acceleration phases.</p> <p><b>3 = Warning Const. Move, "Only warning during constant travel",</b> same as setting "1" but monitoring is inactive during acceleration phases.</p>				

### P525 ... P529 Load control

With the load monitoring, a range can be specified within which the load torque may change depending on the output frequency. There are three auxiliary values for the maximum permissible torque and three auxiliary values for the minimum permissible torque. A frequency is assigned to each of these auxiliary values. No monitoring is carried out below the first and above the third frequency. In addition, the monitoring can be deactivated for minimum and maximum values. As standard, monitoring is deactivated.

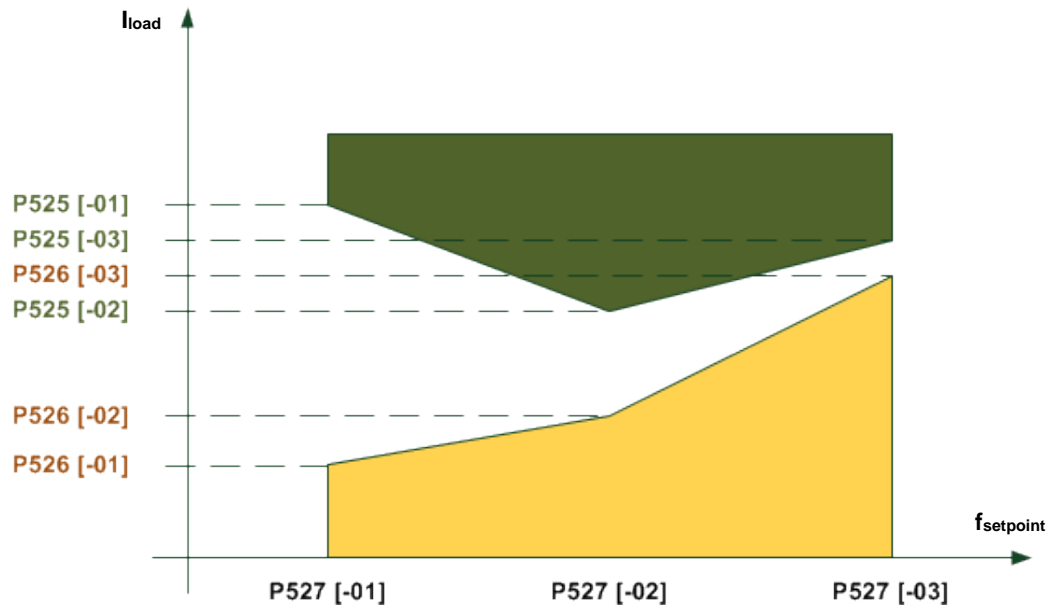

The time after which a fault is triggered can be set with parameter (P528). If the permissible range is exceeded (*Example diagram: Infringement of the area marked in yellow or green*), the error message **E12.5** is generated unless parameter (P529) does not suppress the triggering of an error.

A warning C12.5 is always given after the elapse of half of the set error triggering time (P528). This also applies if a mode is selected for which no fault message is generated. If only a maximum or minimum value is to be monitored, the other limit must be deactivated or must remain deactivated. The torque current and not the calculated torque is used as the reference value. This has the advantage that monitoring in the "non field weakened range" without servo mode is usually more accurate. Naturally however, it cannot display more than the physical torque in the weakened field range.

All parameters depend on parameter sets. No differentiation is made between motor and generator torque, therefore the value of the torque is considered. As well as this, there is no differentiation between "left" and "right" running. The monitoring is therefore independent of the prefix of the frequency. There are four different load monitoring modes (P529).

The frequencies and the minimum and maximum values belong together within the various array elements. The frequencies do not need to be sorted according to their magnitude in the elements 0, 1 and 2, as the variable frequency drive does this automatically.

<b>P533</b>	<b>Factor I<sup>2</sup>t Motor</b> (factor I <sup>2</sup> t motor)		<b>S</b>	
50 ... 150 % { 100 }	The motor current for the I <sup>2</sup> t motor monitoring P535 can be weighted with the parameter P533. Larger factors permit larger currents.			
<b>P534</b>	<b>[ -01 ] Torque disconnection limit</b> <b>[ -02 ]</b> (Torque disconnection limit)		<b>S</b>	<b>P</b>
0 ... 400%/401 { all 401 }	Via this parameter both the <b>motoring</b> [-01] and the <b>regenerative</b> [-02] switch-off value can be adjusted. If 80 % of the set value is reached, a warning status is set. At 100 % switch-off is performed with an error message. Error 12.1 is given on exceeding the drive switch-off limit and 12.2on exceeding the generator switch-off limit.  <div style="display: flex; justify-content: space-around;"> <span><b>[01]</b> = motoring limit</span> <span><b>[02]</b> = regenerative limit</span> </div> <b>401 = OFF,</b> means that this function has been disabled.			

<b>P535</b>	<b>I<sup>2</sup>t motor</b> (I <sup>2</sup> t motor)			
0 ... 24 { 0 }	The motor temperature is calculated depending on the output current, the time and the output frequency (cooling). If the temperature limit value is reached then switch off occurs and error message E002 (motor overheating) is output. Possible positive or negative acting ambient conditions cannot be taken into account here. The I <sup>2</sup> t motor function can be set in a differentiated manner. 8 characteristic curves with three different triggering times (<5 s, <10 s and <20 s) can be set. The trigger times are based on classes 5, 10 and 20 for semiconductor switching devices. The recommended setting for standard applications is P535=5. All curves run from 0 Hz to half of the nominal motor frequency (P201). The full nominal current is available from half of the nominal frequency upwards. With multi-motor operation the monitoring must be disabled. <b>I<sup>2</sup>t motor off</b> Monitoring is inactive			

Switch off class 5, 60 s at (1.5 x I <sub>N</sub> x P533)		Switch off class 10, 120 s at (1.5 x I <sub>N</sub> x P533)		Switch off class 20, 240 s at (1.5 x I <sub>N</sub> x P533)	
I <sub>N</sub> at 0 Hz	P535	I <sub>N</sub> at 0 Hz	P535	I <sub>N</sub> at 0 Hz	P535
100%	1	100%	9	100%	17
90%	2	90%	10	90%	18
80%	3	80%	11	80%	19
70%	4	70%	12	70%	20
<b>60%</b>	<b>5</b>	60%	13	60%	21
50%	6	50%	14	50%	22
40%	7	40%	15	40%	23
30%	8	30%	16	30%	24

**NOTE:** Shut-off classes 10 and 20 are provided for applications with heavy starting. When using these shut-off classes, it must be ensured that the VFD has a sufficiently high overload capacity.

<b>P536</b>	<b>Current limit</b> <i>(current limit)</i>		<b>S</b>	
0.1 ... 2.0/2.1 (x nominal VFD current) { 1.5 }	<p>The VFD output current is limited to the set value. If this limit value is reached, the VFD reduces the actual output frequency.</p> <p>With the analog input function in P400 = 13/14, this limit value can also be varied and cause an error message (E12.4).</p> <p><b>0.1 ... 2.0 = Multiplier</b> with the VFD nominal current, gives the limit value.</p> <p><b>2.1 = OFF</b> means that this limit value is disabled. The VFD supplies the maximum possible current.</p>			
<b>P537</b>	<b>Pulse disconnection</b> <i>(pulse disconnection)</i>		<b>S</b>	
10 ... 200 %/201 { 150 }	<p>This function prevents rapid shutdown of the VFD according to the load. With the pulse switch-off enabled, the output current is limited to the set value. This limitation is implemented by brief switching off of individual output stage transistors, the actual output frequency remains unchanged.</p> <hr/> <p><b>10...200% =      Limit value in relation to nominal VFD current</b></p> <p><b>201 =            The function is</b> so to speak <b>disabled</b>, the VFD supplies the maximum possible current. However, at the current limit the pulse switch off can still be active.</p>			

- NOTE:** The value set here can be undershot by a smaller value in P536.  
At smaller output frequencies (<4.5 Hz) or higher pulse frequencies (>6 kHz or 8 kHz, P504) the pulse switch-off can be undershot by the power reduction ( 8.5).(please see chapter 8.4 "Reduced output power")
- NOTE:** If the pulse switch-off is disabled (P537=201) and a high pulse frequency is selected in parameter P504, the VFD automatically reduces the pulse frequency when the power limit is reached. If the load on the VFD is reduced again, the pulse frequency increases back to the original value.

<b>P539</b>	<b>Check output voltage</b> <i>(output monitoring)</i>		<b>S</b>	<b>P</b>
0 ... 3 { 0 }	This protective function monitors the output current at the U-V-W terminals and checks for plausibility. In cases of error, the error message E016 is output.			
<b>0 = Switched off:</b> Monitoring is not active.				
<b>1 = Motor Phases only:</b> The output current is measured and checked for symmetry. If an imbalance is present, the VFD switches off and outputs the error message E016.				
<b>2 = Magnetisation only:</b> At the moment the VFD is switched on, the level of the excitation current (field current) is checked. If insufficient excitation current is present, the VFD switches off with the error message E016. A motor brake is not released in this phase.				
<b>3 = Motor Phase + Magnet:</b> Monitoring of the motor phases and magnetization as in 1 and 2 are combined.				
<b>NOTE:</b> This function can be used as an additional protective function for lifting applications, but is not permissible on its own as protection for persons.				

<b>P540</b>	<b>Mode phase sequence</b> <i>(rotation direction mode)</i>		<b>S</b>	<b>P</b>
0 ... 7 { 0 }	For safety reasons this parameter can be used to prevent a rotation direction reversal and therefore the incorrect rotation direction.			
This function does not operate with active position control (P600 ≠ 0).				
<b>0 = No limitation, "No restriction of direction of rotation"</b>				
<b>1 = Disable phaseseq. key,</b> rotation direction change key  of the Simple Box is locked				
<b>2 = To the right only*,</b> only clockwise direction is possible. The selection of the "incorrect" rotation direction leads to the output of the minimum frequency P104 with the field of rotation R.				
<b>3 = To the left only*,</b> only counterclockwise direction is possible. The selection of the "incorrect" rotation direction leads to the output of the minimum frequency P104 with the field of rotation L.				
<b>4 = Enable direction only,</b> rotation direction is only possible according to the enable signal, otherwise 0Hz.				
<b>5 = Right Orient. Contr., "Only clockwise monitored" *</b> , only clockwise rotation is possible. The selection of the "incorrect" rotation direction leads to the VFD switching off (control block). If necessary, an adequately large setpoint value (>fmin) must be observed.				
<b>6 = Left Orient. Contr., "Only counterclockwise monitored" *</b> , only counterclockwise rotation is possible. The selection of the "incorrect" rotation direction leads to the VFD switching off (control block). If necessary, an adequately large setpoint value (>fmin) must be observed.				
<b>7 = Enable Direct. Contr. only, "Only enabled direction monitored,</b> Rotation direction is only possible according to the enable signal, otherwise the VFD is switched off.				

\*) Applies for control via keyboard and control terminals.



<b>P541</b>	<b>Set relays</b> <i>(set digital output)</i>		<b>S</b>	
-------------	--	--	----------	--

0000 ... FFF (hex)  
{ 0000 }

This function provides the opportunity to control the relay and the digital outputs independently of the variable frequency drive status. To do this, the relevant output must be set to the function "External control".

This function can either be used manually or in combination with a bus control.

- |  |  |
|--|--|
| <b>Bit 0</b> = Digital output 1  | <b>Bit 6</b> = Bus/An/Dig Out Bit 5,<br>"Bus/Analog/Digital Out Bit 5" |
| <b>Bit 1</b> = Bus/AS-i Out Bit 0                                      | <b>Bit 7</b> = Bus digital output 7                                    |
| <b>Bit 2</b> = Bus/AS-i Out Bit 1                                      | <b>Bit 8</b> = Bus digital output 8                                    |
| <b>Bit 3</b> = Bus/AS-i Out Bit 2                                      | <b>Bit 9</b> = Bus statusword Bit10                                    |
| <b>Bit 4</b> = Bus/AS-i Out Bit 3                                      | <b>Bit 10</b> = Bus statusword Bit13                                   |
| <b>Bit 5</b> = Bus/An/Dig Out Bit 4,<br>"Bus/Analog/Digital Out Bit 4" | <b>Bit 11</b> = Digital output 2                                       |

	Bits 8-11	Bits 7-4	Bits 3-0	
Min. value	0000 <b>0</b>	0000 <b>0</b>	0000 <b>0</b>	Binary <b>hex</b>
Max. value	1111 <b>F</b>	1111 <b>F</b>	1111 <b>F</b>	Binary <b>hex</b>

Changes which are made to the settings are not saved in the EEPROM. After "Power ON" of the variable frequency drive, the parameter is therefore in the default setting.

Setting of the value via ...

**BUS:** The corresponding hex value is written into the parameter, thereby setting the relay and digital outputs.

**Simple Box:** The hexadecimal code is entered directly when the Simple Box is used.

**Parameter Box:** Each individual output can be separately called up in plain text and activated.

<b>P542</b>	[-01] [-02]	<b>Set analog output</b> <i>(set analog output)</i>		<b>S</b>	
-------------	----------------	--	--	----------	--

0.0 ... 10.0 V  
{ all 0.0 }

... only with  
SK CU4-IOE or  
SK TU4-IOE

**[-01]** = IOE-1, AOUT of the **first** I/O extension (SK xU4IOE)

**[-02]** = IOE-2, AOUT of the **second** I/O extension (SK xU4IOE)

The analog output of the VFD can be set with this function, independently of the actual operating state. To do this, the relevant analog output must be set to the function "External control" (P418 = 7).

This function can either be used manually or in combination with a bus control. The value set here will, once confirmed, be produced at the analog output.

Changes which are made to the settings are not saved in the EEPROM. After "Power ON" of the variable frequency drive, the parameter is therefore in the default setting.

P543 [-01] ... [-03]	Bus actual value 1 ... 3 <i>(actual bus value 1 ... 3)</i>	S	P
0 ... 57 { [-01] = 1 } { [-02] = 4 } { [-03] = 9 }	<p>The return status value can be selected for bus actuation in this parameter.</p> <p><b>NOTE:</b> For further details, please refer to the relevant bus manual or the description for (P418). (Values from 0% ... 100% correspond to 0000hex ... 4000hex) For standardization of the actual values: (please see chapter 8.9 "Standardization of setpoint/target values").</p>		
<p><b>[-01] = bus actual value 1      [-02] = bus actual value 2      [-03] = bus actual value 3</b></p>			
<p>(Definition of frequencies (chapter 8.10))</p>			
<p><b>0 =</b> Off</p> <p><b>1 =</b> Actual frequency</p> <p><b>2 =</b> Actual speed</p> <p><b>3 =</b> Current</p> <p><b>4 =</b> Torque current (100% = P112)</p> <p><b>5 =</b> State digital-IO</p> <p><b>6 =</b> ... 7 reserved, Posicon <a href="#">BU0210</a></p> <p><b>8 =</b> Setpoint frequency</p> <p><b>9 =</b> Error code</p> <p><b>10 =</b> ... 11 reserved, Posicon <a href="#">BU0210</a></p> <p><b>12 =</b> BusIO Out Bits 0-7</p> <p><b>13 =</b> ... 16 reserved, Posicon <a href="#">BU0210</a></p> <p><b>17 =</b> Value analog input 1, <b>SK2x0E:</b> Analog input 1 (P400[-01]), <b>SK2x5E:</b> AIN1 of the first I/O extension SK xU4-IOE (P400 [-03])</p> <p><b>18 =</b> Value analog input 2, <b>SK2x0E:</b> Analog input 2 (P400[-02]), <b>SK2x5E:</b> AIN2 of the first I/O extension SK xU4-IOE (P400 [-04])</p>	<p><b>19 =</b> Frequency Master Value (P503)</p> <p><b>20 =</b> Set frequency After Ramp, <i>"Setpoint frequency after master value ramp"</i></p> <p><b>21 =</b> Actual freq. without slip <i>"Actual frequency without master value slip"</i></p> <p><b>22 =</b> Speed encoder, <i>"Speed from encoder"</i></p> <p><b>23 =</b> Actual frequency with slip <i>(from software version V1.3)</i> <i>"Actual frequency with slip"</i></p> <p><b>24 =</b> Lead actual freq. w. slip <i>(SW 1.3 and above)</i> <i>"Master value, actual freq. with slip"</i></p> <p><b>53 =</b> Actual value 1 PLC</p> <p><b>54 =</b> Actual value 2 PLC</p> <p><b>55 =</b> Actual value 3 PLC</p> <p><b>56 =</b> Actual value 4 PLC</p> <p><b>57 =</b> Actual value 5 PLC</p>		

\* assignment of the digital inputs for P543 = 5

Bit 0 = DigIn 1 (VFD)	Bit 1 = DigIn 2 (VFD)	Bit 2 = DigIn 3 (VFD)	Bit 3 = DigIn 4 (VFD)
Bit 4 = PTC thermistor input (VFD)	Bit 5 = reserved	Bit 6 = DigOut 3 (DO1, 1st SK...IOE)	Bit 7 = DigOut 4 (DO2, 1st SK...IOE)
Bit 8 = DigIn 5 (DI1, 1st SK...IOE)	Bit 9 = DigIn 6 (DI2, 1st SK...IOE)	Bit 10 = DigIn 7 (DI3, 1st SK...IOE)	Bit 11 = DigIn 8 (DI4, 1st SK...IOE)
Bit 12 = DigOut 1 (VFD)	Bit 13 = mech. brake (VFD)	Bit 14 = DigOut 2 (VFD) (SK 2x0E)	Bit 15 = reserved





<b>P553</b>	[-01] ... [-05]	<b>PLC set values</b> <i>(PLC setpoints)</i>	<b>S</b>	<b>P</b>
0 ... 36 all = { 0 }	The PLC setpoints are assigned with a function in this parameter. The settings only apply for main setpoints and with active PLC actuation ((P350) = "On") and ((P351) = "0" or "1").			
<b>[-01] = Bus setpoint 1</b>		...	<b>[-05] = Bus setpoint 5</b>	
<b>Possible values which can be set:</b>				
<b>0 =</b> Off	<b>17 =</b> Multiplication			
<b>1 =</b> Setpoint frequency	<b>18 =</b> Curve control			
<b>2 =</b> Frequency addition	<b>19 =</b> Servo-mode torque			
<b>3 =</b> Frequency subtraction	<b>20 =</b> BusIO In Bits 0-7			
<b>4 =</b> Minimum frequency	<b>21 =</b> Setpoint pos. LowWord			
<b>5 =</b> Maximum frequency	<b>22 =</b> Setpoint pos. HighWord			
<b>6 =</b> Current value process ctrl	<b>23 =</b> Setpoint pos. Inc. LowWord			
<b>7 =</b> Nom. val. process ctrl.	<b>24 =</b> Setpoint pos. Inc. HighWord			
<b>8 =</b> PID current freq.	<b>25 =</b> Ratio gearing			
<b>9 =</b> PI ltd. current freq.	<b>26 =</b> ... 30: reserved			
<b>10 =</b> PI suprvsd. cur. freq.	<b>31 =</b> Digital output IOE			
<b>11 =</b> Torque current limit (limiting)	<b>32 =</b> Analog output IOE			
<b>12 =</b> Torque current switch-off limit	<b>33 =</b> Setval. torque p. reg.			
<b>13 =</b> Current limit (limiting)	<b>34 =</b> d-corr. F process			
<b>14 =</b> Current switch-off limit	<b>35 =</b> d-corr. Torque			
<b>15 =</b> Ramp time	<b>36 =</b> d-corr. F+Torque			
<b>16 =</b> Pre-tension torque				

<b>P555</b>	<b>P-limit chopper</b> ( <i>chopper power limit</i> )		<b>S</b>	
5 ... 100 % { 100 }	<p>With this parameter it is possible to program a manual (peak) power limit for the braking resistor. The switch-on delay (modulation level) for the chopper can only rise to a certain maximum specified limit. Once this value is reached, irrespective of the level of the DC link voltage, the VFD switches off the current to the resistor.</p> <p>The result would be an overvoltage switch-off of the VFD.</p> <p>The correct percentage value is calculated as follows: <math>k[\%] = \frac{R * P_{\max BW}}{U_{\max}^2} * 100\%</math></p> <p>R = Resistance of the braking resistor  P<sub>maxBW</sub> = Momentary peak power of the braking resistor  U<sub>max</sub> = VFD chopper operating point</p> <p>1~ 115/230 V ⇒ 440 V=  3~ 230 V ⇒ 500 V=  3~ 400 V ⇒ 1000 V=</p>			
<p><b>i Information</b></p> <ul style="list-style-type: none"> <li>Use of an <i>external braking resistor</i>: DIP switch <b>S1:8</b>: Setting "0" (<b>Off</b>). Set the parameters according to the braking resistor that is being used.</li> <li>Use of an <i>internal braking resistor</i>: DIP switch <b>S1:8</b>: Setting "I" (<b>On</b>). Parameter settings have no effect.</li> </ul> <p>(chapter 2.3.2) (chapter 2.3.1) (chapter 4.3.2.2)</p>				
<b>P556</b>	<b>Braking resistor</b> ( <i>braking resistor</i> )		<b>S</b>	
1 ... 400 Ω { 120 }	<p>Value of the brake resistance for the calculation of the maximum braking power to protect the resistor.</p> <p>Once the maximum continuous output (<b>P557</b>) including overload (200 % for 60 s) is reached, an I<sup>2</sup>t limit error (E003.1) is triggered. Further details in (<b>P737</b>).</p>			
<p><b>i Information</b></p> <ul style="list-style-type: none"> <li>Use of an <i>external braking resistor</i>: DIP switch <b>S1:8</b>: Setting "0" (<b>Off</b>). Set the parameters according to the braking resistor that is being used.</li> <li>Use of an <i>internal braking resistor</i>: DIP switch <b>S1:8</b>: Setting "I" (<b>On</b>). Parameter settings have no effect.</li> </ul> <p>(chapter 2.3.2) (chapter 2.3.1) (chapter 4.3.2.2)</p>				
<b>P557</b>	<b>Brake resistor type</b> ( <i>Braking resistor power</i> )		<b>S</b>	
0.00 ... 20.00 kW { 0.00 }	<p>Continuous power (nominal power) of the resistor, to display the actual utilization in (<b>P737</b>). For a correctly calculated value, the correct value must be entered into (<b>P556</b>) and (<b>P557</b>).</p> <p><b>0.00 = Off</b>, monitoring disabled</p>			
<p><b>i Information</b></p> <ul style="list-style-type: none"> <li>Use of an <i>external braking resistor</i>: DIP switch <b>S1:8</b>: Setting "0" (<b>Off</b>). Set the parameters according to the braking resistor that is being used.</li> <li>Use of an <i>internal braking resistor</i>: DIP switch <b>S1:8</b>: Setting "I" (<b>On</b>). Parameter settings have no effect.</li> </ul> <p>(chapter 2.3.2) (chapter 2.3.1) (chapter 4.3.2.2)</p>				

<b>P558</b>	<b>Flux delay</b> <i>(magnetization time)</i>		<b>S</b>	<b>P</b>
0 / 1 / 2 ... 5000 ms { 1 }	<p>The ISD control can only function correctly if there is a magnetic field in the motor. For this reason, a DC current is applied before starting the motor to provide the excitation of the stator winding. The duration depends on the size of the motor and is automatically set in the factory setting of the VFD.</p> <p>For time-critical applications, the magnetizing time can be set or deactivated.</p> <p><b>0</b> = Disabled  <b>1</b> = Automatic calculation  <b>2 ... 5000</b> = Time set in [ms]</p> <p><b>NOTE:</b> Setting values that are too low can reduce the dynamics and starting torque.</p>			
<b>P559</b>	<b>DC Run-on time</b> <i>(DC run-on time)</i>		<b>S</b>	<b>P</b>
0.00 ... 30.00 s { 0.50 }	<p>Following a stop signal and the braking ramp, a direct current is briefly applied to the motor to fully bring the drive to a stop. Depending on the inertia, the time for which the current is applied can be set in this parameter.</p> <p>The current level depends on the previous braking procedure (current vector control) or the static boost (linear characteristic).</p>			
<b>P560</b>	<b>Mode of parameter save</b> <i>(parameter saving mode)</i>		<b>S</b>	
0 ... 2 { 1 }	<p><b>0</b> = <b>RAM only</b>, changes to the parameter settings are no longer saved on the EEPROM. All previously saved settings are retained, even if the VFD is disconnected from the power.</p> <p><b>1</b> = <b>RAM and EEPROM</b>, all parameter changes are automatically written to the EEPROM and remain stored there even if the VFD is disconnected from the power supply.</p> <p><b>2</b> = <b>OFF</b>, no saving in RAM <u>and</u> EEPROM possible (<u>no</u> parameter changes are accepted)</p> <p><b>NOTE:</b> If BUS communication is used to implement parameter changes, it must be ensured that the maximum number of write cycles (100,000 x) in the EEPROM is not exceeded.</p> <p><i>PLC:</i> A stored PLC program is also protected by the settings "0" or "2". However, with the setting "0" the PLC program can also not be loaded or executed.</p>			

### 5.2.7 Positioning

Parameter group P6xx is used to adjust the positioning control or the position control. In order to make this parameter visible, set the supervisor parameter P003 to 2 or 3.

A detailed description of these parameters can be found in manual [BU0210](#).



### 5.2.8 Informations

Parameter	Setting value/description/note		Supervisor	Parameter set
<b>P700</b>	[-01] <b>Actual operating status</b> ... [-03] <i>(present operating status)</i>			
0.0 ... 25.4	<p>Display of current messages for the present operating status of the variable frequency drive such as faults, warnings or the reason why switch-on is disabled (please see chapter 6 "Operating status messages").</p> <p><b>[-01] = Actual fault</b>, shows the currently active (unacknowledged) fault(please see section "Error messages").</p> <p><b>[-02] = Actual warning</b>, indicates a current warning message (please see section "Warning messages").</p> <p><b>[-03] = Reason VFD blocked</b>, indicates the reason for an active start disable (please see section "Notifications switch-on block, "not ready").</p> <p><b>NOTE</b>  <i>Simple Box/Control Box:</i> the error numbers of the warning messages and faults can be displayed using Simple Box and Control Box.  <i>Parameter box:</i> with the Parameter box the messages are displayed in plain text. In addition, the reason for a possible disabling of starting can also be displayed.  <i>Bus:</i> The display of bus-level error messages is displayed in decimal integer format. The displayed value must be divided by 10 in order to correspond with the correct format.            Example: Display: 20 → Error number: 2.0</p>			
<b>P701</b>	[-01] <b>Last fault</b> ... [-05] <i>(Last fault 1...5)</i>			
0.0 ... 25.4	<p>This parameter stores the last 5 faults (please see chapter 0 "Error messages").</p> <p>The Simple Box/Control Box must be used to select the corresponding memory location 1...5- (array parameter), and confirmed using the OK/ENTER key to read the stored error code.</p>			
<b>P702</b>	[-01] <b>Frequency last error</b> ... [-05] <i>(last frequency fault 1...5)</i>		<b>S</b>	
-400.0 ... 400.0 Hz	<p>This parameter stores the output frequency that was being delivered at the time the fault occurred. The values of the last 5 errors are stored.</p> <p>The Simple Box/Control Box must be used to select the corresponding memory location 1...5- (array parameter), and confirmed using the OK/ENTER key to read the stored value.</p>			

<b>P703</b>	[ -01 ] ... [ -05 ]	<b>Current. Last error</b> <i>(last current fault 1...5)</i>		<b>S</b>	
0.0 ... 999.9 A	<p>This parameter stores the output current that was being delivered at the time the fault occurred. The values of the last 5 errors are stored.</p> <p>The Simple Box/Control Box must be used to select the corresponding memory location 1...5- (array parameter), and confirmed using the OK/ENTER key to read the stored value.</p>				
<b>P704</b>	[ -01 ] ... [ -05 ]	<b>Voltage last error</b> <i>(last voltage error 1...5)</i>		<b>S</b>	
0 ... 600 V AC	<p>This parameter stores the output voltage that was being delivered at the time the fault occurred. The values of the last 5 errors are stored.</p> <p>The Simple Box/Control Box must be used to select the corresponding memory location 1...5- (array parameter), and confirmed using the OK/ENTER key to read the stored value.</p>				
<b>P705</b>	[ -01 ] ... [ -05 ]	<b>Dc. lnk volt. Last error</b> <i>(last DC link voltage fault 1...5)</i>		<b>S</b>	
0 ... 1000 V DC	<p>This parameter stores the DC link voltage that was being delivered at the time the fault occurred. The values of the last 5 errors are stored.</p> <p>The Simple Box/Control Box must be used to select the corresponding memory location 1...5- (array parameter), and confirmed using the OK/ENTER key to read the stored value.</p>				
<b>P706</b>	[ -01 ] ... [ -05 ]	<b>P set last error</b> <i>(parameter set, last fault 1... 5)</i>		<b>S</b>	
0 ... 3	<p>This parameter stores the parameter set code that was active when the error occurred. Data for the previous 5 faults are stored.</p> <p>The Simple Box/Control Box must be used to select the corresponding memory location 1...5- (array parameter), and confirmed using the OK/ENTER key to read the stored error code.</p>				
<b>P707</b>	[ -01 ] ... [ -03 ]	<b>Software-Version</b> <i>(Software version/revision)</i>			
0.0 ... 9999.9	<p>This parameter shows the software and revision numbers in the VFD. This can be significant when different VFDs are assigned the same settings.</p> <p>Array 03 provides information about any special versions of the hardware or software. A zero stands for the standard version.</p> <p>... [-01] = version number (Vx.x) ... [-02] = revision number (Rx) ... [-03] = special version of hardware/software (0.0)</p>				

<b>P708</b>	<b>State of digital input</b> <i>(digital input status)</i>		
-------------	--	--	--

00000 ... 11111 (bin)  
or  
0000 ... FFFF (hex)

Displays the status of the digital inputs in binary/hexadecimal code. This display can be used to check the input signals.

**Bit 0** = Digital input 1  
**Bit 1** = Digital input 2  
**Bit 2** = Digital input 3  
**Bit 3** = Digital input 4  
**Bit 4** = PTC resistor input  
**Bits 5 - 7** reserved

First SK xU4-IOE (optional)

**Bit 8** = 1st IO extension: Digital input 1  
**Bit 9** = 1st IO extension: Digital input 2  
**Bit 10** = 1st IO extension: Digital input 3  
**Bit 11** = 1st IO extension: Digital input 4

Second SK xU4-IOE (optional)

**Bit 12** = 2nd IO extension: Digital input 1  
**Bit 13** = 2nd IO extension: Digital input 2  
**Bit 14** = 2nd IO extension: Digital input 3  
**Bit 15** = 2nd IO extension: Digital input 4

	Bits 15-12	Bits 11-8	Bits 7-4	Bits 3-0	
<b>Minimum value</b>	0000	0000	0000	0000	Binary
	0	0	0	0	<b>hex</b>
<b>Maximum value</b>	1111	1111	1111	1111	Binary
	F	F	F	F	<b>hex</b>

**Simple Box:** The binary bits are converted to a hexadecimal value and displayed.

**Parameter Box:** The bits are displayed increasing from right to left (binary).

<b>P709</b>	[-01] ... [-09]	<b>Analog input voltage</b> <i>(analog input voltage)</i>		
-------------	-----------------------	--	--	--

-100 ... 100 %

Displays the measured analog input value.

SK 2x0E	SK 2x5E
---------	---------

**[-01] = Analog input 1**, value of analog input 1 integrated in the VFD.

**[-01] = Potentiometer 1**, internal potentiometer P1 in the VFD (chapter 4.3.2), for setting the maximum frequency, minimum frequency and ramp time

**[-02] = Analog input 2**, value of analog input 2 integrated in the VFD.

**[-02] = Potentiometer 2**, same as potentiometer 1

**SK 2xxE**

**[-03] = Ext. Analog in 1**, AIN 1 of the first SK xU4-IOE I/O extension

**[-04] = Ext. Analog in 2**, AIN2 of the first SK xU4-IOE I/O extension

**[-05] = Setpoint module**, SK SSX-3A, see [BU0040](#)

**SK 2xxE, size 1 – 3**

**[-06] = Analog function dig.. 2**, analog function of VFD digital input 2

**[-07] = Analog function dig.. 3**, analog function of VFD digital input 3

**SK 2x0E, size 4**

**[-06] = Potentiometer 1**, internal potentiometer P1 in the VFD (chapter 4.3.2), for setting the maximum frequency, minimum frequency and ramp time

**[-07] = Potentiometer 2**, same as potentiometer 1



<b>P718</b>	<b>Current setpoint frequency</b> <i>(present setpoint frequency)</i>			
	[-01] ... [-03]			
-400.0 ... 400.0 Hz	Displays the frequency specified by the setpoint (please see chapter 8.1 "Setpoint processing"). [-01] = present setpoint frequency from the setpoint source [-02] = present setpoint frequency after processing in the VFD status machine [-03] = present setpoint frequency after frequency ramp			
<b>P719</b>	<b>Actual current</b> <i>(present current)</i>			
0.0 ... 999.9 A	Displays the present output current.			
<b>P720</b>	<b>Actual torque current</b> <i>(present torque current)</i>			
-999.9 ... 999.9 A	Displays the currently calculated torque-generating output current (active current). Basis for calculation are the motor data P201...P209. → negative values = generator, → positive values = drive			
<b>P721</b>	<b>Actual field current</b> <i>(present field current)</i>			
-999.9 ... 999.9 A	Displays the presently calculated field current (reactive current). Basis for calculation are the motor data P201...P209.			
<b>P722</b>	<b>Current voltage</b> <i>(present voltage)</i>			
0 ... 500 V	Displays the actual AC voltage supplied by the VFD output.			
<b>P723</b>	<b>Voltage -d</b> <i>(present voltage component Ud)</i>		<b>S</b>	
-500 ... 500 V	Displays the present field voltage component.			
<b>P724</b>	<b>Voltage -q</b> <i>(present voltage component Uq)</i>		<b>S</b>	
-500 ... 500 V	Displays the present torque voltage component.			
<b>P725</b>	<b>Current cos phi</b> <i>(present cosj)</i>			
0.00 ... 01:00	Displays the presently calculated cos φ of the drive.			
<b>P726</b>	<b>Apparent power</b> <i>(apparent power)</i>			
0.00 ... 300.00 kVA	Displays the presently calculated apparent power. Basis for calculation are the motor data P201...P209.			
<b>P727</b>	<b>Mechanical power</b> <i>(mechanical power)</i>			
--99.99 ... 99.99 kW	Displays the presently calculated effective power of the motor. Basis for calculation are the motor data P201...P209.			

<b>P728</b>	<b>Input voltage</b> ( <i>input voltage</i> )			
0 ... 1000 V	Displays the actual line voltage at the VFD input. This is determined indirectly from the value of the DC link voltage.			
	<b>i Information</b>	<b>Display of static value</b>		
	In devices with a separate 24 V supply, a static value is displayed if <i>no line voltage</i> is present (e.g.: with 1~ 230 V devices: P728 = 230 V). This value is used for internal initialization purposes.			
<b>P729</b>	<b>Torque</b> ( <i>Torque</i> )			
-400 ... 400 %	Displays the actual calculated torque. Basis for calculation are the motor data P201...P209.			
<b>P730</b>	<b>Field</b> ( <i>Field</i> )			
0 ... 100 %	Displays the actual field in the motor calculated by the VFD. Basis for calculation are the motor data P201...P209.			
<b>P731</b>	<b>Parameter set</b> ( <i>current parameter set</i> )			
0 ... 3	Shows the actual operating parameter set.			
	0 = Parameter set 1	2 = Parameter set 3		
	1 = Parameter set 2	3 = Parameter set 4		
<b>P732</b>	<b>Phase U current</b> ( <i>U phase current</i> )		<b>S</b>	
0.0 ... 999.9 A	Displays the actual U phase current. <b>NOTE:</b> This value can deviate somewhat from the value in P719, due to the measurement procedure used, even with symmetrical output currents.			
<b>P733</b>	<b>Phase V current</b> ( <i>V phase current</i> )		<b>S</b>	
0.0 ... 999.9 A	Displays the actual V phase current. <b>NOTE:</b> This value can deviate somewhat from the value in P719, due to the measurement procedure used, even with symmetrical output currents.			
<b>P734</b>	<b>Phase W current</b> ( <i>W phase current</i> )		<b>S</b>	
0.0 ... 999.9 A	Displays the actual W phase current. <b>NOTE:</b> This value can deviate somewhat from the value in P719, due to the measurement procedure used, even with symmetrical output currents.			
<b>P735</b>	<b>Speed encoder</b> ( <i>encoder speed</i> )		<b>S</b>	
-9999 ... 9999 rpm	Displays the actual rotation speed supplied by the incremental encoder. For this, P301 must be correctly set.			

<b>P736</b>		<b>Dc. link voltage</b> <i>(DC link voltage)</i>			
0 ... 1000 V DC		Displays the actual DC link voltage.			
		<b><span style="border: 1px solid black; padding: 0 2px;">i</span> Information</b>	<b>Display of untypical value</b>		
<p>In devices with a separate 24 V supply, a small, non-typical value is displayed if <i>no line voltage</i> is present (e.g.: with 1~ 230 V devices: P736 ≈ 4 V). This value results from internal measuring and testing routines, and is dependent upon measuring errors, offsets and signal noise, for example.</p>					
<b>P737</b>		<b>Usage rate brakeres.</b> <i>(present braking resistor load)</i>			
0 ... 1000 %		<p>This parameter provides information about the actual degree of modulation of the brake chopper or the current utilization of the braking resistor in generator mode.</p> <p>If parameters P556 and P557 are correctly set, the utilization related to P557, the resistor power, is displayed.</p> <p>If only P556 is correctly set (P557=0), the degree of modulation of the brake chopper is displayed. Here, 100 means that the braking resistor is fully switched. On the other hand, 0 means that the brake chopper is not active at present.</p> <p>If P556 = 0 and P557 = 0, this parameter also provides information about the degree of modulation of the brake chopper in the VFD.</p>			
<b>P738</b>	[-01] [-02]	<b>Usage rate motor</b> <i>(present motor load)</i>			
0 ... 1000 %		<p>Shows the actual motor load. Basis for calculation are the motor data P203. The actually recorded current is related to the nominal motor current.</p> <p><b>[-01] = related to <math>I_N</math> (P203) of the motor</b>  <b>[-02] = related <math>I^2t</math> control, "in relation to <math>I^2t</math> monitoring" (P535)</b></p>			
<b>P739</b>	[-01] ... [-03]	<b>Heatsink temperature</b> <i>(present heat sink temperature)</i>			
-40 ... 150°C		<p><b>[-01] = Heat sink temperature</b> of VFD  <b>[-02] = Ambient temperature</b> of VFD  <b>[-03] = Temp. Motor KTY</b>, motor temperature via KTY</p>			

<b>P741</b>	<b>[ -01 ]</b> ... <b>[ -19 ]</b>	<b>PZD bus Out</b> <i>(Process data Bus Out)</i>		<b>S</b>	
0000 ... FFFF (hex)	This parameter provides information about the actual status word and the actual values that are transferred via the bus systems.  Standardization: (  Section 8.9 "Standardization setpoint/target values")	<ul style="list-style-type: none"> <li><b>[ -01 ]</b> = Status word</li> <li><b>[ -02 ]</b> = actual value 1 (P543)</li> <li><b>[ -03 ]</b> = actual value 2 (...)</li> <li><b>[ -04 ]</b> = actual value 3 (...)</li> <li><b>[ -05 ]</b> = res. Stat. OutBit P481</li> <li><b>[ -06 ]</b> = Parameter data Out 1</li> <li><b>[ -07 ]</b> = Parameter data Out 2</li> <li><b>[ -08 ]</b> = Parameter data Out 3</li> <li><b>[ -09 ]</b> = Parameter data Out 4</li> <li><b>[ -10 ]</b> = Parameter data Out 5</li> <li><b>[ -11 ]</b> = Actual value 1 leadfunct.</li> <li><b>[ -12 ]</b> = Actual value 2 leadfunct.</li> <li><b>[ -13 ]</b> = Actual value 3 leadfunct.</li> <li><b>[ -14 ]</b> = Statusword PLC</li> <li><b>[ -15 ]</b> = Actual value 1 PLC</li> <li>...</li> <li><b>[ -19 ]</b> = PLC 5 actual value</li> </ul>	Status word, source from P509.	Actual values	The displayed value depicts all Bus OUT Bit sources linked with an "OR".
					Data during parameter transfer.
					Actual value of leadfunction P502/P503.
					Status word + actual values on PLC
<b>P742</b>		<b>Data base version</b> <i>(database version)</i>		<b>S</b>	
0 ... 9999	Displays the internal database version of the VFD.				
<b>P743</b>		<b>Inverter ID</b> <i>(inverter type)</i>			
0.00 ... 250.00	Displays the VFD power in kW, e.g. "1.50" ⇒ VFD with 1.5 kW nominal power.				



<b>P744</b>	<b>Configuration level</b> <i>(configuration level)</i>			
0000 ... FFFF (hex)	This parameter displays the devices integrated in the VFD. Display is in hexadecimal code (Simple Box, bus system). The display is in plain text when the Parameter box is used.			
	<b>High byte:</b>		<b>Low byte:</b>	
		00 <sub>hex</sub>	Standard I/O	(SK 205E)
		01 <sub>hex</sub>	STO	(SK 215E)
00 <sub>hex</sub>	No extension	02 <sub>hex</sub>	AS-i	(SK 225E)
01 <sub>hex</sub>	Encoder	03 <sub>hex</sub>	STO and AS-i	(SK 235E)
02 <sub>hex</sub>	Posicon	04 <sub>hex</sub>	Standard I/O	(SK 200E)
03 <sub>hex</sub>	---	05 <sub>hex</sub>	STO	(SK 210E)
		06 <sub>hex</sub>	AS-i	(SK 220E)
		07 <sub>hex</sub>	STO and AS-i	(SK 230E)

<b>P747</b>	<b>Inverter voltage range</b> <i>(inverter voltage range)</i>			
0 ... 2	Indicates the line voltage range for which this device is specified.			
	<b>0</b> = 100 – 120 V	<b>1</b> = 200 – 240 V	<b>2</b> = 380-480 V	

<b>P748</b>	<b>Status CANopen</b> <i>(CANopen status (system bus statu))</i>			
0000 ... FFFF (hex)	Shows the status of the system bus.			
or				
0 ... 65535 (dec)	Bit 0:	24 V bus supply voltage		
	Bit 1:	CANbus in "Bus Warning" status		
	Bit 2:	CANbus in "Bus Off" status		
	Bit 3:	System bus → Bus module online (field bus module, e.g.: SK xU4-PBR)		
	Bit 4:	System bus → Additional module 1 online (I/O - module, e.g.: SK xU4-IOE)		
	Bit 5:	System bus → Additional module 2 online (I/O - module, e.g.: SK xU4-IOE)		
	Bit 6:	The protocol of the CAN module is <b>0</b> = CAN/ <b>1</b> = CANopen		
	Bit 7:	Vacant		
	Bit 8:	"Bootup Message" sent		
	Bit 9:	CANopen NMT State		
	Bit 10:	CANopen NMT State		
		CANopen NMT State	Bit 10	Bit 9
		Stopped	0	0
		Pre-operational	0	1
		Operational	1	0

<b>P749</b>	<b>Status DIP-switches</b> <i>(Status of DIP switches)</i>			
0000 ... 01FF (hex) or 0 ... 511 (dec)	This parameter shows the current setting of the S1 VFD DIP switch (please see chapter 4.3.2.2 "DIP switches (S1)").			
	Bit 0:	DIP switch 1		
	Bit 1:	DIP switch 2		
	Bit 2:	DIP switch 3		
	Bit 3:	DIP switch 4		
	Bit 4:	DIP switch 5		
	Bit 5:	DIP switch 6		
	Bit 6:	DIP switch 7		
	Bit 7:	DIP switch 8		
<i>Bit 8: from SW 1.3</i>	Bit 8:	EEPROM (memory module)	Bit 8 = 0: plugged in/Bit 8 = 1: not plugged in	
<b>P750</b>	<b>Stat. overcurrent</b> <i>(overcurrent statistics)</i>		<b>S</b>	
0 ... 9999	Number of overcurrent messages during the operating period P714.			
<b>P751</b>	<b>Stat. Overvoltage</b> <i>(overvoltage statistics)</i>		<b>S</b>	
0 ... 9999	Number of overvoltage messages during the operating period P714.			
<b>P752</b>	<b>Stat. mains failure</b> <i>(Mains fault statistics)</i>		<b>S</b>	
0 ... 9999	Number of grid faults during operating period P714.			
<b>P753</b>	<b>Stat. Overtemperature</b> <i>(Overtemperature statistics)</i>		<b>S</b>	
0 ... 9999	Number of overtemperature faults during the operating period P714.			
<b>P754</b>	<b>Stat. parameter lost</b> <i>(parameter loss statistics)</i>		<b>S</b>	
0 ... 9999	Number of parameters lost during the operating period P714.			

<b>P755</b>	<b>Stat. System error</b> <i>(system faults statistics)</i>		<b>S</b>	
0 ... 9999	Number of system faults during the operating period P714.			
<b>P756</b>	<b>Stat. Timeout</b> <i>(Timeout statistics)</i>		<b>S</b>	
0 ... 9999	Number of Time out errors during the operating period P714.			
<b>P757</b>	<b>Stat. Customer error</b> <i>(Customer error statistics)</i>		<b>S</b>	
0 ... 9999	Number of Customer Watchdog faults during the operating period P714.			
<b>P760</b>	<b>Input current</b> <i>(present line current)</i>		<b>S</b>	
0.0 ... 999.9 A	Displays the actual input current.			
<b>P780</b>	<b>Device ID</b> <i>(Device ID)</i>			
0 ... 9 and A...Z (char) { 0 }	Display of the serial number (14-digit) of the device. <ul style="list-style-type: none"> <li>- Display via NORDCON: as a coherent serial number of the device.</li> <li>- Display via Bus: ASCII code (decimal). Each array must be read out separately.</li> </ul>			
<b>P799</b>	<b>Op.-time last error</b> <i>(Operating time, last fault 1...5)</i>			
0.1 ... ____ h	This parameter shows the operating hours counter status (P714) at the moment of the last fault. Array 01...05 corresponds to the last fault 1...5.			

## 6 Operating status messages

The device and technology units generate appropriate messages if they deviate from their normal operating status. There is a differentiation between warning and error messages. If the device is in the status "Start disabled", the reason for this can also be displayed.

The messages generated for the device are displayed in the corresponding array of parameter (**P700**). The display of the messages for technology units is described in the respective additional instructions and data sheets for the modules concerned.

### Switch-on block, "not ready" → (**P700 [-03]**)

If the device is in the status "Not Ready" or "Start Disabled", the reason for this is indicated in the third array element of parameter (**P700**).

Display is only possible with the NORD CON software or the Parameter Box (SK PAR-3H).

### Warning messages → (**P700 [-02]**)

Warning messages are generated as soon as a defined limit is reached. However this does not cause the variable frequency drive to switch off. These messages can be displayed via the array-element [-02] in parameter (**P700**) until either the reason for the warning is no longer present or the variable frequency drive has gone into a fault state with an error message.

### Fault messages → (**P700 [-01]**)

Faults cause the device to switch off, in order to prevent a device fault.

The following options are available to reset a fault (acknowledge):

- Switching power off and on,
  - By an appropriately programmed digital input (**P420**),
  - By switching off the "enable" on the device (if no digital input is programmed for acknowledgement),
  - By bus acknowledgement
- 
- By **P506**, automatic error acknowledgement.

### 6.1 Display of messages

#### LED displays

The device status is indicated by integrated and externally visible status LEDs included in the factory default kit. Depending on the device model, this is a two-color LED (DS = Device State) or two monochromatic LEDs (DS Device State and DE = Device Error).

<b>Meaning:</b>	<p><b>Green</b> indicates the standby status and the presence of mains voltage. During operation an increasingly rapid flashing code indicates the degree of overload of the device output.</p> <p><b>Red</b> indicates the presence of an error by flashing with a frequency which corresponds to the number code of the fault. This flashing code indicates the error groups (e.g.: E003 = 3x flashes).</p>
-----------------	---

#### SimpleBox display

The SimpleBox displays a fault with its number and the prefix "E". In addition, the current fault can be displayed in array element [-01] of parameter (**P700**) . The last fault messages are stored in parameter **P701**. Please refer to parameters **P702** to **P706/P799** for further information on device status at the time the fault occurs.

If the cause of the fault is no longer present, the error display in the SimpleBox flashes and the error can be acknowledged with the Enter key.

In contrast, warning messages are prefixed with "C" ("**Cxxx**") and cannot be acknowledged. They disappear automatically when the reason for them is no longer present or the device has switched to the Fault state. Display of the message is suppressed if the warning appears during parameterization.

The current warning message can be displayed in detail at any time in array element [-02] of parameter (**P700**).

The reason for an existing disabled switch on cannot be displayed with the SimpleBox.

#### Parameter Box display

The Parameter Box displays messages in plain text.

### 6.2 Diagnostic LEDs on device

The device generates operating status messages. These messages (warnings, errors, switching statuses, measurement data) can be  3.1.1 "Use of control and parameterization units" displayed with parameterization tools (e.g. Parameter Box) (parameter group **P7xx**).

To a limited extent, the messages are also indicated via the diagnostic and status LEDs.

### 6.2.1 Diagnostic LEDs on SK 2x0E (size 1 ... 3)

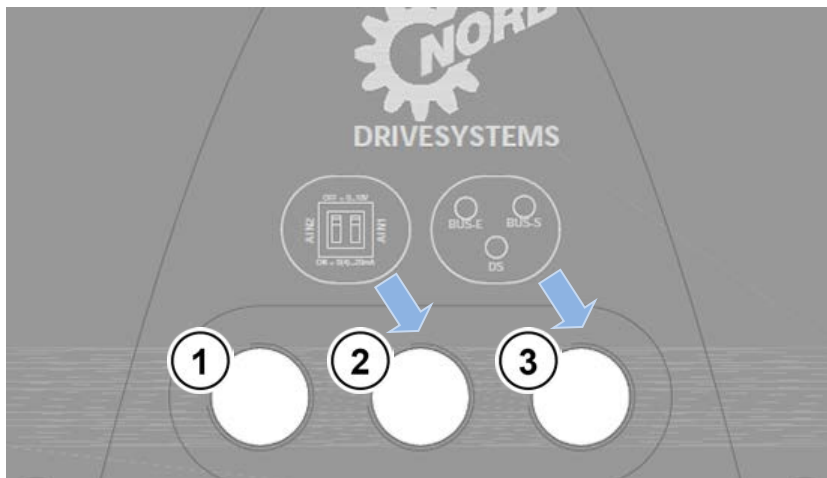

- 1 RJ12, RS 232, RS 485
- 2 DIP switch AIN1/2
- 3 Diagnostic LEDs

Figure 29: Diagnostic openings SK 2x0E (size 1 ... 3)

#### Diagnostic LEDs

LED		Description	Signal status		Meaning
Name	Color				
BUS-S	green	System bus Status	off		No process data communication
			Flashing	4 Hz	"BUS Warning"
			On		Process data communication active → Receipt of at least 1 telegram/s → SDO data transfer is not indicated
BUS-E	red	System bus Error	off		No error
			Flashing	4 Hz	Monitoring error P120 or P513 → E10.0/E10.9
			Flashing	1 Hz	Error in an external system bus module → Bus module → Timeout on the external BUS (E10.2) → System bus module has a module error (E10.3)
			On		System bus in state "BUS off"
DS	dual red/green	VFD status	off		VFD not on standby, → no line and control voltage
			green on		VFD is enabled (VFD running)
			flashing green	0.5 Hz	VFD is in standby or not enabled
				4 Hz	VFD is in switch-on block
			red/green alternating	4 Hz	Warning
			flashing red	1 Hz	Degree of overload of switched-on VFD
				Error, flashing frequency → error number	

### 6.2.2 Diagnostic LEDs on the SK 2x0E (size 4) and SK 4x5E

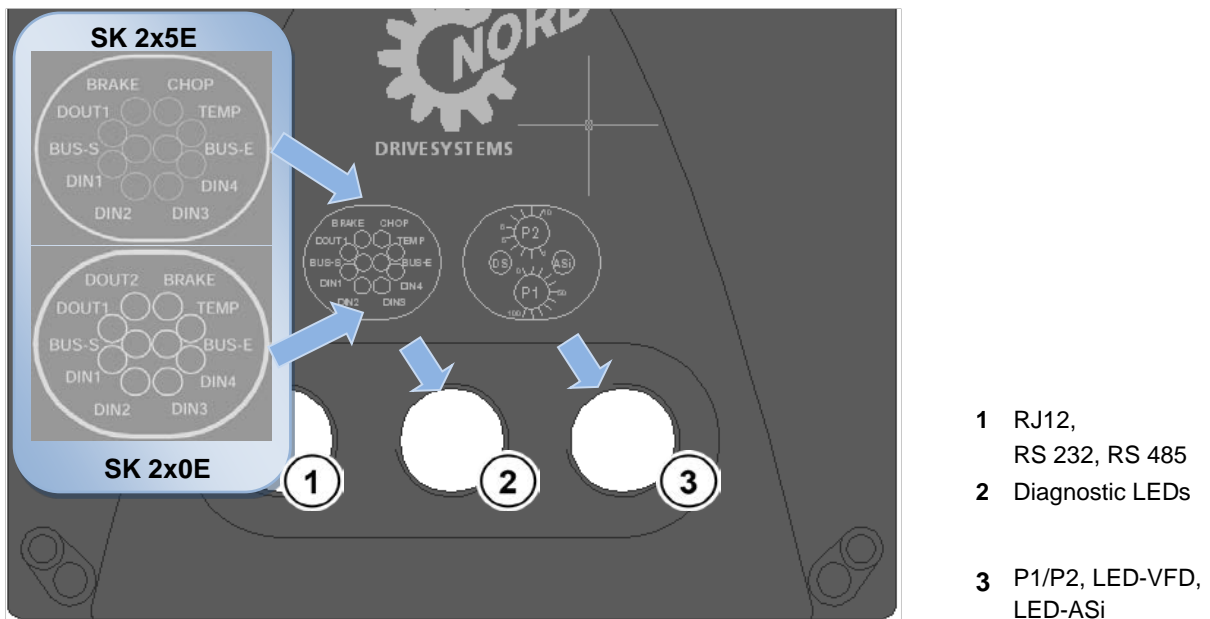

Figure 30: Diagnostic openings SK 2x0E size 4 or SK 4x5E

#### Status LEDs

LED			Signal		
Name	Color	Description	Status		Meaning
DS	dual red/green	VFD status	off		VFD not on standby, → no line and control voltage
			green on		VFD is enabled (VFD running)
			green	0.5 Hz	VFD is in standby or not enabled
			Flashing	4 Hz	VFD is in switch-on block
			red/green	4 Hz	Warning
			Alternating	1 Hz	Degree of overload of switched-on VFD
			green on + flashing red		VFD not on standby, → Control voltage available but no line voltage
flashing red		Error, flashing frequency → error number			
AS-i	dual red/green	Status AS-i			Details (📖 Section 4.5 "AS interface (AS-i)")

### Diagnostic LEDs

LED			Signal	
Name	Color	Description	Status	Meaning
DOUT 1	yellow	Digital output 1	on	High signal applied
DIN 1	yellow	Digital input 1	on	High signal applied
DIN 2	yellow	Digital input 2	on	High signal applied
DIN 3	yellow	Digital input 3	on	High signal applied
DIN 4	yellow	Digital input 4	on	High signal applied
TEMP	yellow	Motor PTC thermistor	on	Motor overtemperature
CHOP	yellow	Brake chopper	on	Brake chopper active, brightness → degree of load ( <i>only SK 2x5E</i> )
BRAKE	yellow	Mech. Brake	on	Mech. Brake released
DOUT 2	yellow	Digital output 2	on	High signal present ( <i>only SK 2x0E</i> )
BUS-S	green	System bus Status	off	No process data communication
			Flashing (4 Hz)	"BUS Warning"
			On	Process data communication active → Receipt of at least 1 telegram/s → SDO data transfer is not indicated
BUS-E	red	System bus Error	off	No error
			Flashing (4 Hz)	Monitoring error P120 or P513 → E10.0/E10.9
			Flashing (1 Hz)	Error in an external system bus module → Bus module → Timeout on external BUS (E10.2) → System bus module has module error (E10.3)
			on	System bus in state "BUS off"



### 6.3 Messages

#### Error messages

Display in the Simple Box/Control Box		Fault Text in the Parameter Box	Cause • Remedy
Group	Details in P700 [-01] / P701		
E001	1.0	<b>Overtemp. inverter</b> <i>"Inverter overtemperature"</i> (inverter heat sink)	Temperature monitoring of the inverter Measuring results lie outside the permissible temperature range, that is, the error is triggered when falling short of the permissible lower temperature limit or when exceeding the permissible upper temperature limit. <ul style="list-style-type: none"> <li>Depending on cause: Reduce or increase ambient temperature</li> <li>Check device fan/cabinet ventilation</li> <li>Check the device for dirt</li> </ul>
	1.1	<b>Overtemp. VFD internal</b> <i>"Internal VFD overtemperature"</i> (internal area of the variable frequency drive)	
E002	2.0	<b>Overtemp. Motor PTC</b> <i>"Overtemperature motor PTC"</i>	Motor temperature sensor (PTC thermistor) has triggered <ul style="list-style-type: none"> <li>Reduce motor load</li> <li>Increase motor speed</li> <li>Use external motor fan</li> </ul>
	2.1	<b>Overtemp. I<sup>2</sup>t motor</b> <i>"Overtemperature I<sup>2</sup>t motor"</i>  Only if I <sup>2</sup> t motor (P535) is programmed.	I <sup>2</sup> t motor has triggered (calculated overtemperature of motor) <ul style="list-style-type: none"> <li>Reduce motor load</li> <li>Increase motor speed</li> </ul>
	2.2	<b>Overtemp. ext. brak. res.</b> <i>"Overtemperature of external braking resistor"</i>  Overtemperature via digital input (P420 [...])={13}	Temperature monitor (e.g. braking resistor) has activated <ul style="list-style-type: none"> <li>Digital input is low</li> <li>Check connection, temperature sensor</li> </ul>

E003	3.0	I <sup>2</sup> t overcurrent limit	a.c. VFD: I <sup>2</sup> t limit has triggered, e.g. > 1.5 x I <sub>n</sub> for 60 s (also note P504) <ul style="list-style-type: none"> <li>• Continuous overload at VFD output</li> <li>• Possible encoder fault (resolution, defect, connection)</li> </ul>
	3.1	Chopper overtemperature I <sup>2</sup> t	Brake chopper: I <sup>2</sup> t limit has activated, 1.5 times values reached for 60 s (please also pay attention to P554, if present, and P555, P556, P557) <ul style="list-style-type: none"> <li>• Avoid overcurrent in brake resistance</li> </ul>
	3.2	IGBT overcurrent 125% monitoring	Derating (output reduction) <ul style="list-style-type: none"> <li>• 125% overcurrent for 50 ms</li> <li>• Brake chopper current too high</li> <li>• For fan drives: enable flying start circuit (P520)</li> </ul>
	3.3	IGBT overcurrent fast 150% monitoring	Derating (output reduction) <ul style="list-style-type: none"> <li>• 150% overcurrent</li> <li>• Brake chopper current too high</li> </ul>
E004	4.0	Overcurrent module	Error signal from module (short duration) <ul style="list-style-type: none"> <li>• Short circuit or ground fault at VFD output</li> <li>• Motor cable is too long</li> <li>• Use external output choke</li> <li>• Braking resistor faulty or resistance too low</li> </ul> <p><b>→ Do not switch off P537!</b></p> <p><b>The occurrence of a fault can significantly shorten the service life of the VFD or even destroy it.</b></p>
	4.1	Overcurrent measurement <i>"Overcurrent measurement"</i>	P537 (pulse current switch-off) was reached 3x within 50 ms (only possible if P112 and P536 are disabled) <ul style="list-style-type: none"> <li>• VFD is overloaded</li> <li>• Drive sluggish, insufficiently sized,</li> <li>• Ramps (P102/P103) too steep -&gt; Increase ramp time</li> <li>• Check motor data (P201 ... P209)</li> </ul>
E005	5.0	Overvoltage U <sub>d</sub>	DC link voltage too high <ul style="list-style-type: none"> <li>• Increase deceleration time (P103)</li> <li>• If necessary, set switch-off mode (P108) with delay (not with lifting equipment)</li> <li>• Extend emergency stop time (P426)</li> <li>• Fluctuating speed (e.g. due to high centrifugal masses), →adjust U/f characteristic curve if necessary (P211, P212)</li> </ul> Devices with brake chopper: <ul style="list-style-type: none"> <li>• Reduce energy return using a braking resistor</li> <li>• Check the function of the connected braking resistor (broken cable)</li> <li>• Resistance value of connected braking resistor too high</li> </ul>
	5.1	Mains overvoltage	Line voltage is too high <ul style="list-style-type: none"> <li>• See technical data (📖 Section 7)</li> </ul>
E006	6.0	Charging error	DC link voltage is too low <ul style="list-style-type: none"> <li>• Line voltage too low</li> <li>• See technical data (📖 Section 7)</li> </ul>
	6.1	Mains low voltage	Line voltage too low <ul style="list-style-type: none"> <li>• See technical data (📖 Section 7)</li> </ul>

## 6 Operating status messages

E007	7.0	<b>Mains phase failure</b>	Fault on supply connection side <ul style="list-style-type: none"> <li>• A power phase is not connected</li> <li>• Line power is asymmetric</li> </ul>
	7.1	<b>Phase failure dc-link</b>	DC link voltage too low <ul style="list-style-type: none"> <li>• A power phase is not connected</li> <li>• Load temporarily too high</li> </ul>
	<b>On 7.1</b>		<b>Devices with external 24 V DC supply of the control unit:</b> If the line voltage is switched off, but the control unit is still supplied with 24 V DC, this error message also occurs. If the line voltage is switched on again, the error message must be acknowledged. It is not before until then that the variable frequency drive can be released.
E008	8.0	<b>Parameter loss</b> (maximum EEPROM value exceeded)	Error in EEPROM data <ul style="list-style-type: none"> <li>• Software version of the stored data set not compatible with the software version of the VFD.</li> </ul> <b>NOTE:</b> <u>Faulty parameters</u> are automatically reloaded (default data). <ul style="list-style-type: none"> <li>• EMC interferences (see also E020)</li> </ul>
	8.1	<b>Inverter ID error, “Inverter type incorrect”</b>	<ul style="list-style-type: none"> <li>• EEPROM faulty</li> </ul>
	8.2	<b>Reserved</b>	
	8.3	<b>EEPROM KSE error</b> (Customer unit incorrectly identified (customer's interface equipment))	The upgrade level of the variable frequency drive was not correctly identified. EEPROM with a firmware status of version 1.2 or above plugged in to an VFD with older firmware status → <b>Loss of parameters!</b> (also see <i>Information</i> in section 5)
	8.4	<b>Internal EEPROM error</b> (Database version incorrect)	<ul style="list-style-type: none"> <li>• Switch line voltage off and on again.</li> </ul>
	8.7	<b>EEPROM copy differs, “EEPR copy not the same”</b>	
E009	---	<b>Reserved</b>	

E010	<b>10.0</b>	<b>Bus timeout</b>	(Telegram timeout/bus off 24 V int. CANbus) <ul style="list-style-type: none"> <li>• Data transfer is faulty. Check P513.</li> <li>• Check physical bus connections</li> <li>• Check bus protocol program process.</li> <li>• Check bus master.</li> <li>• Check 24 V supply of internal CAN/CANopen bus.</li> <li>• <i>Node guarding</i> error (internal CANopen)</li> <li>• <i>Bus off</i> error (internal CANbus)</li> </ul>
	<b>10.2</b>	<b>Bus timeout option</b>	Telegram timeout <ul style="list-style-type: none"> <li>• Telegram transfer is faulty.</li> <li>• Check physical bus connections</li> <li>• Check bus protocol program process.</li> <li>• Check bus master.</li> <li>• PLC is in the "STOP" or "ERROR" state.</li> </ul>
	<b>10.4</b>	<b>Init error option</b>	Initialization error in bus module <ul style="list-style-type: none"> <li>• Check bus module current supply.</li> <li>• DIP switch setting of a connected I/O extension module is incorrect</li> </ul>
	<b>10.1</b>	<b>System error option</b>	System error bus module
	<b>10.3</b>		<ul style="list-style-type: none"> <li>• Further details can be found in the respective additional bus instructions.</li> </ul>
	<b>10.5</b>		<u>I/O extension:</u>
<b>10.6</b>	Incorrect measurement of the input voltage or undefined provision of the output voltage due to error in reference voltage generation. <ul style="list-style-type: none"> <li>• Short circuit at analog output</li> </ul>		
<b>10.7</b>			
<b>10.9</b>	<b>Module missing/P120</b>	The module entered in parameter (P120) is not available. <ul style="list-style-type: none"> <li>• Check connections</li> </ul>	
E011	<b>11.0</b>	<b>Control terminals</b>	A/D inverter error Internal customer unit (internal data bus) faulty or damaged by radio radiation (EMC) <ul style="list-style-type: none"> <li>• Check control connections for short circuit.</li> <li>• Minimize EMC interference by laying control and power cables separately.</li> <li>• Device and shielding must be well grounded.</li> </ul>
E012	<b>12.0</b>	<b>External watchdog</b>	The Watchdog function is selected at a digital input and the impulse at the corresponding digital input is not present for longer than the time set in parameter P460 >Watchdog time<. <ul style="list-style-type: none"> <li>• Check connections</li> <li>• Check setting P460</li> </ul>
	<b>12.1</b>	<b>Limit moto./Customer</b> <i>"Motor switch-off limit"</i>	The drive switch-off limit (P534 [-01]) has triggered. <ul style="list-style-type: none"> <li>• Reduce load on motor</li> <li>• Set higher value in (P534 [-01]).</li> </ul>
	<b>12.2</b>	<b>Limit gen.</b> <i>"Generator switch-off limit"</i>	The generator switch-off limit (P534 [-02]) has triggered. <ul style="list-style-type: none"> <li>• Reduce load on motor</li> <li>• Set higher value in (P534 [-02]).</li> </ul>
	<b>12.3</b>	<b>Torque limit</b>	Limit from potentiometer or setpoint source has switched off. P400 = 12

## 6 Operating status messages

	12.4	<b>Current limit</b>	Limit from potentiometer or setpoint source has switched off. P400 = 14
	12.5	<b>Load monitor</b>	Switch-off due to overshooting or undershooting of permissible load torques ((P525) ... (P529)) for the time set in (P528). <ul style="list-style-type: none"> <li>• Adjust load</li> <li>• Change limit values ((P525) ... (P527))</li> <li>• Increase delay time (P528)</li> <li>• Change monitoring mode (P529)</li> </ul>
	12.8	<b>AI minimum,</b> <i>"Analog In minimum"</i>	Switch-off due to undershooting of the 0% adjustment value (P402) with setting (P401) "0-10 V with switch-off on error 1" or "...2"
	12.9	<b>AI maximum,</b> <i>"Analog In maximum"</i>	Switch-off due to overshooting of the 100% adjustment value (P402) with setting (P401) "0-10 V with switch-off on error 1" or "...2"
E013	13.0	<b>Encoder error</b>	No signal from encoder <ul style="list-style-type: none"> <li>• Check 5 V sensor if available</li> <li>• Check supply voltage of encoder</li> </ul>
	13.1	<b>Speed slip error</b> <i>"Speed slip error"</i>	The slip speed error limit was reached. <ul style="list-style-type: none"> <li>• Increase value in P327</li> </ul>
	13.2	<b>Disconnect. control,</b> <i>"Shut-down monitoring"</i>	The slip error monitoring was triggered; the motor could not follow the setpoint. <ul style="list-style-type: none"> <li>• Check motor data P201-P209! (important for current controllers)</li> <li>• Check motor circuit</li> <li>• Check encoder settings P300 and following in servo mode</li> <li>• Increase value for torque limit in P112</li> <li>• Increase value for current limit in P536</li> <li>• Check deceleration time P103 and extend if necessary</li> </ul>
	13.5	<b>Reserved</b>	Error message for POSICON → see supplementary manual
	13.6	<b>Reserved</b>	Error message for POSICON → see supplementary manual
E014	---	<b>Reserved</b>	Error message for POSICON → see supplementary manual
E015	---	<b>Reserved</b>	
E016	16.0	<b>Motor phase error</b>	A motor phase is not connected. <ul style="list-style-type: none"> <li>• Check P539</li> <li>• Check motor connection</li> </ul>
	16.1	<b>Magn. Current Watch</b> <i>"Magnetizing current monitoring"</i>	Required exciting current not achieved at moment of switch-on. <ul style="list-style-type: none"> <li>• Check P539</li> <li>• Check motor connection</li> </ul>
E018	18.0	<b>Reserved</b>	Error message for "Safe Pulse Block", see supplementary instructions
E019	19.0	<b>parameter ident.</b> <i>"Parameter identification"</i>	Automatic identification of the connected motor was unsuccessful

	<b>19.1</b>	<b>Star/delta incorrect</b> <i>"Motor star/delta circuit incorrect"</i>	<ul style="list-style-type: none"> <li>• Check motor connection</li> <li>• Check preset motor data (P201 ... P209)</li> <li>• PMSM – CFC Closed Loop Operation: Rotor position of motor incorrect in relation to incremental encoder Determine rotor position (initial enable after a "Power On" only with motor stationary) (P330)</li> </ul>
E020	<b>20.0</b>	<b>Reserved</b>	<p>System error in program execution, triggered by EMC interference.</p> <ul style="list-style-type: none"> <li>• Observe wiring guidelines</li> <li>• Use additional external mains filter</li> <li>• VFD must be very well grounded</li> </ul>
E021	<b>20.1</b>	<b>Watchdog</b>	
	<b>20.2</b>	<b>Stack overflow</b>	
	<b>20.3</b>	<b>Stack underflow</b>	
	<b>20.4</b>	<b>Undefined opcode</b>	
	<b>20.5</b>	<b>Protected Instruct.</b> <i>"Protected Instruction"</i>	
	<b>20.6</b>	<b>Illegal word access</b>	
	<b>20.7</b>	<b>Illegal Inst. Access</b> <i>"Illegal instruction access"</i>	
	<b>20.8</b>	<b>Prog. memory error</b> <i>"Program memory error"</i> (EEPROM error)	
	<b>20.9</b>	<b>Dual-ported RAM</b>	
	<b>21.0</b>	<b>NMI error</b> (Not used by hardware)	
	<b>21.1</b>	<b>PLL error</b>	
	<b>21.2</b>	<b>ADU error "Overrun"</b>	
	<b>21.3</b>	<b>PMI error "Access Error"</b>	
	<b>21.4</b>	<b>User stack overflow</b>	
E022	---	<b>Reserved</b>	Error message for PLC → see supplementary manual <a href="#">BU 0550</a>
E023	---	<b>Reserved</b>	Error message for PLC → see supplementary manual <a href="#">BU 0550</a>
E024	---	<b>Reserved</b>	Error message for PLC → see supplementary manual <a href="#">BU 0550</a>

### Warning messages

Display in the Simple Box/Control Box		Warning	Cause • Remedy
Group	Details in P700 [-02]	Text in the Parameter Box	
C001	1.0	<b>Inverter overtemp.</b> <i>"Inverter overtemperature"</i> (inverter heat sink)	Temperature monitoring of the inverter Warning, permissible temperature limit reached. <ul style="list-style-type: none"> <li>• Reduce ambient temperature</li> <li>• Check device fan/cabinet ventilation</li> <li>• Check the device for dirt</li> </ul>
C002	2.0	<b>Motor overtemp. PTC</b> <i>"Motor overtemp. PTC"</i>	Warning from motor temperature sensor (triggering threshold reached) <ul style="list-style-type: none"> <li>• Reduce motor load</li> <li>• Increase motor speed</li> <li>• Use external motor fan</li> </ul>
	2.1	<b>Motor overtemp. I<sup>2</sup>t</b> <i>"Motor overtemperature I<sup>2</sup>t"</i>  Only if I <sup>2</sup> t motor (P535) is programmed.	Warning: I <sup>2</sup> t motor monitoring (1.3 times the rated current reached for the time period specified in (P535)) <ul style="list-style-type: none"> <li>• Reduce motor load</li> <li>• Increase motor speed</li> </ul>
	2.2	<b>Ext Resistor Temp</b> <i>"Overtemperature of external braking resistor"</i>  Overtemperature via digital input (P420 [...])={13}	Warning: Temperature monitor (e.g. braking resistor) has activated <ul style="list-style-type: none"> <li>• Digital input is low</li> </ul>
C003	3.0	<b>I<sup>2</sup>t overcurrent limit</b>	Warning: a.c. inverter: I <sup>2</sup> t limit has triggered, e.g. > 1.3 x I <sub>n</sub> for 60 s (also note P504) <ul style="list-style-type: none"> <li>• Continuous overload at inverter output</li> </ul>
	3.1	<b>Chopper overtemperature I<sup>2</sup>t</b>	Warning: I <sup>2</sup> t limit for the brake chopper has activated, 1.3 times values reached for 60 s (please also pay attention to P554, if present, and P555, P556, P557) <ul style="list-style-type: none"> <li>• Avoid overcurrent in brake resistance</li> </ul>
	3.5	<b>Torque current limit</b>	Warning: Torque current limit reached <ul style="list-style-type: none"> <li>• Check (P112)</li> </ul>
	3.6	<b>Current limit</b>	Warning: Current limit reached <ul style="list-style-type: none"> <li>• Check (P536)</li> </ul>

C004	4.1	<b>Overcurrent measurem</b> "Overcurrent measurement"	Warning: pulse switch off is active The limit for activation of pulse switch off (P537) has been reached (only possible if P112 and P536 are switched off) <ul style="list-style-type: none"> <li>• VFD is overloaded</li> <li>• Drive sluggish, insufficiently sized,</li> <li>• Ramps (P102/P103) too steep -&gt; Increase ramp time</li> <li>• Check motor data (P201 ... P209)</li> <li>• Switch off slip compensation (P212)</li> </ul>
C008	8.0	<b>Parameter loss</b>	Warning: One of the cyclically saved messages such as <i>operating hours</i> or <i>enabling time</i> could not be saved successfully. The warning disappears as soon as saving can be successfully performed.
C012	12.1	<b>Limit moto./Customer</b> "Motor switch-off limit"	Warning: 80% of the drive switch-off limit (P534 [-01]) has been exceeded. <ul style="list-style-type: none"> <li>• Reduce load on motor</li> <li>• Set higher value in (P534 -[01])</li> </ul>
	12.2	<b>Limit gen.</b> "Generator switch-off limit"	Warning: 80% of the generator switch-off limit (P534 [-02]) has been reached. <ul style="list-style-type: none"> <li>• Reduce load on motor</li> <li>• Set higher value in (P534 [-02]).</li> </ul>
	12.3	<b>Torque limit</b>	Warning: 80% of the limit from the potentiometer or the setpoint source has been reached. P400 = 12
	12.4	<b>Current limit</b>	Warning: 80% of the limit from the potentiometer or the setpoint source has been reached. P400 = 14
	12.5	<b>Load monitor</b>	Warning due to overshooting or undershooting of permissible load torques ((P525) ... (P529)) for the time set in (P528). <ul style="list-style-type: none"> <li>• Adjust load</li> <li>• Change limit values ((P525) ... (P527))</li> <li>• Increase delay time (P528)</li> </ul>



### Notifications switch-on block, "not ready"

Display in the SimpleBox / ControlBox		Reason: Text in the ParameterBox	Cause • Remedy
Group	Details in P700 [-03]		
I000	0.1	<b>Disable voltage from IO</b>	If the "disable voltage" function is parameterized, input (P420/P480) is Low <ul style="list-style-type: none"> <li>• "Set high" input</li> <li>• Check signal cable (broken cable)</li> </ul>
	0.2	<b>IO fast stop</b>	If the function "fast stop" is parameterized, input (P420/P480) is at low <ul style="list-style-type: none"> <li>• "Set high" input</li> <li>• Check signal cable (broken cable)</li> </ul>
	0.3	<b>Block voltage from bus</b>	<ul style="list-style-type: none"> <li>• Bus operation (P509): control word bit 1 is "low"</li> </ul>
	0.4	<b>Bus fast stop</b>	<ul style="list-style-type: none"> <li>• Bus operation (P509): control word bit 2 is "low"</li> </ul>
	0.5	<b>Enable on start</b>	Enable signal (control word, Dig I/O or Bus I/O) was already applied during the initialization phase (after line power "ON", or control voltage "ON"). Or electrical phase is lacking. <ul style="list-style-type: none"> <li>• Only issue enable signal after completion of initialization (i.e. when the VFD is ready)</li> <li>• Activation of "Automatic Start" (P428)</li> </ul>
	0.6 – 0.7	<b>Reserved</b>	Information message for PLC → see supplementary instructions
	0.8	<b>Right direction blocked</b>	Switch-on block with inverter shut-off activated by: <b>P540</b> or by "Enable right block" ( <b>P420</b> = 31, 73) or "Enable left block" ( <b>P420</b> = 32, 74), The variable frequency drive switches to "Ready for switching on" status
	0.9	<b>Left direction blocked</b>	
	I006 <sup>1)</sup>	6.0	<b>Charging error</b>
I011	11.0	<b>Analog Stop</b>	If an analog input of the variable frequency drive or a connected IO extension is configured to detect cable breaks (2-10 V signal or 4-20 mA signal), the variable frequency drive switches to the status "ready for switch-on" if the analog signal undershoots the value <b>1 V</b> or <b>2 mA</b> This also occurs if the relevant analog input is parameterized to function "0" ("no function"). <ul style="list-style-type: none"> <li>• Check connection</li> </ul>
I014 <sup>1)</sup>	14.4	<b>Reserved</b>	Information message for POSICON → see supplementary manual
I018 <sup>1)</sup>	18.0	<b>Reserved</b>	Information message for "Safe stop" function → see supplementary manual

1) Indication of operating mode (message) on the *Parameter Box* or virtual operating unit of the *NORD CON-Software*: "Not ready"

## 6.4 FAQ operational problems

Fault	Possible cause	Remedy
Device will not start (all LEDs off)	<ul style="list-style-type: none"> <li>No line voltage or wrong line voltage</li> <li>SK 2x5E: No 24 V DC control voltage</li> </ul>	<ul style="list-style-type: none"> <li>Check connections and supply cables</li> <li>Check switches/fuses</li> </ul>
Device does not react to enabling	<ul style="list-style-type: none"> <li>Control elements not connected</li> <li>Incorrect control word source setting</li> <li>Right and left enable signals present simultaneously</li> <li>Enable signal present before device ready for operation (device expecting a 0 → 1 flank)</li> </ul>	<ul style="list-style-type: none"> <li>Reset enable</li> <li>Reset <b>P428</b> if necessary: "0" = device expecting a 0→1/"1" flank = device reacts to "level" → <b>Danger: Drive can start up independently!</b></li> <li>Check control connections</li> <li>Check <b>P509</b></li> </ul>
Motor will not start in spite of enable being present	<ul style="list-style-type: none"> <li>Motor cables not connected</li> <li>Brake not ventilating</li> <li>No setpoint specified</li> <li>Incorrect setpoint source setting</li> </ul>	<ul style="list-style-type: none"> <li>Check connections and supply cables</li> <li>Check control elements</li> <li>Check <b>P510</b></li> </ul>
Device switches off without error message when load increases (increased mechanical load/speed)	<ul style="list-style-type: none"> <li>Line phase missing</li> </ul>	<ul style="list-style-type: none"> <li>Check connections and supply cables</li> <li>Check switches/fuses</li> </ul>
Motor rotating in wrong direction	<ul style="list-style-type: none"> <li>Motor cable: U-V-W interchanged</li> </ul>	<ul style="list-style-type: none"> <li>Motor cable: Change 2 phases</li> <li>Alternatively: <ul style="list-style-type: none"> <li>– Check motor phase sequence (<b>P583</b>)</li> <li>– Change Enable right/left functions (<b>P420</b>)</li> <li>– Swap control word bits 11/12 (with bus actuation)</li> </ul> </li> </ul>
Motor not reaching required speed	<ul style="list-style-type: none"> <li>Maximum frequency parameter setting too low</li> </ul>	<ul style="list-style-type: none"> <li>Check <b>P105</b></li> </ul>

<p>Motor speed does not correspond to setpoint</p>	<ul style="list-style-type: none"> <li>• Analog input function set to "Frequency additions" and another setpoint is present</li> </ul>	<ul style="list-style-type: none"> <li>• Check <b>P400</b></li> <li>• Check setting of integrated potentiometer (<b>P1</b>) (only SK 2x5E)</li> <li>• <b>P420</b>, check active fixed frequencies</li> <li>• Check bus setpoints</li> <li>• Check <b>P104/P105</b> "min/max frequency"</li> <li>• Check <b>P113</b> "jog frequency"</li> </ul>
<p>Motor generating a considerable amount of noise (at the current limit) and "OFF" signal is implemented at slow speed with little or no control, possibly with error message 3.0</p>	<ul style="list-style-type: none"> <li>• Tracks A and B swapped by encoder (for speed feedback)</li> <li>• Incorrect encoder resolution setting</li> <li>• Encoder power supply missing</li> <li>• Encoder faulty</li> </ul>	<ul style="list-style-type: none"> <li>• Check encoder connections</li> <li>• Check <b>P300, P301</b></li> <li>• Monitor via <b>P735</b></li> <li>• Check encoder</li> </ul>
<p>Intermittent communication error between VFD and optional modules</p>	<ul style="list-style-type: none"> <li>• System bus terminating resistors incorrectly set</li> <li>• Poor connection contact</li> <li>• Faults on system bus line</li> <li>• Maximum system bus length exceeded</li> </ul>	<ul style="list-style-type: none"> <li>• First and last subscriber only: set DIP switches for terminating resistor</li> <li>• Check connections</li> <li>• Connect GND of all VFDs connected to system bus</li> <li>• Pay attention to routing regulations (separate routing of signal and control cables and power and motor cables)</li> <li>• Check cable lengths (system bus)</li> </ul>

Table 14: FAQ operational problems

## 7 Technical Data

### 7.1 General data for variable frequency drive

Function	Specification
Output frequency	0.0 ... 400.0 Hz
Pulse frequency	3.0 ... 16.0 kHz, factory setting = 6 kHz Power reduction > 8 kHz with 115 / 230 V device, > 6 kHz with 400 V device
Typical overload capacity	150% for 60 s, 200% for 3.5 s
Efficiency	> 95% according to size
Insulation resistance	> 5 MΩ
Operating/ambient temperature	-25°C ... +40°C, for detailed information (among others UL-values) about individual device models and operating modes, please see (chapter 7.2). ATEX: -20...+40°C (chapter 2.6)
Storage and transport temperature	-25°C ... +60/70°C
Long-term storage	(chapter 9.1)
Degree of protection	IP55, optional IP66 (chapter 1.9) NEMA1, higher NEMA classifications upon request
Max. installation altitude above sea level	<i>Up to 1000 m</i> No power reduction  <i>1000 m...2000 m:</i> 1 % / 100 m power reduction, overvoltage category 3 <i>2000 m...4000 m:</i> 1%/100 m power reduction, overvoltage category 2, external overvoltage protection required at power input
Ambient conditions	<i>Transport (IEC 60721-3-2):</i> Mechanical: 2M2 <i>Operation (IEC 60721-3-3):</i> Mechanical: 3M7, 3M6 (size 4) Climatic: 3K3 (IP55) 3K4 (IP66)
Environmental protection	<i>Energy-saving function</i> (chapter 8.7), see P219 <i>EMC</i> (chapter 8.3) <i>RoHS</i> (chapter 1.6)
Protective measures against	Overtemperature of the variable frequency drive Short circuit, ground fault, overload, idle running Overvoltage and undervoltage
Motor temperature monitoring	I <sup>2</sup> t motor, PTC/bimetallic switch
Regulation and control	Sensorless current vector control (ISD), linear V/f characteristic, VFC open-loop, CFC open-loop, CFC closed-loop
Waiting time between two power-up cycles	60 s for all devices in normal operating cycle
Interfaces	<i>Standard</i> RS485 (USS) (for parameterization units only) RS232 (Single Slave) System bus <i>Optional</i> AS-i on board (chapter 4.5) Various bus modules (chapter 1.2)
Electrical isolation	Control terminals
Connecting terminals, electrical connection	<i>Power unit</i> (chapter 2.4.2) <i>Control unit</i> (chapter 2.4.3)

## 7.2 Electrical data

The following table lists the electrical data for variable frequency drives. The details based on measurement series for the operating modes are for orientation purposes and may deviate in practice. The measurement series were made at the rated speed with 4-pole NORD standard motors

The following factors have a particular influence on the determined limiting values:

### Wall mounting

- Installation location
- Influence from adjacent devices
- Additional air currents

and also with

### Motor mounting

- Model of motor used,
- Size of motor used
- Speed with internally ventilated motors
- Use of external fans.

---

### Information

### Single-phase operation

With single-phase operation (115 V / 230 V), the mains impedance must be at least 100  $\mu$ H per string. If this is not the case, a line choke must be located upstream.

Failure to comply with this may cause damage to the device due to impermissible current loads on the components.

---

### Information

### Information about current and power

The powers stated for the operating modes are only a rough categorization

The current values are more reliable details for the selection of the correct variable frequency drive/motor combination!

---

The following tables contain the data which is relevant as per UL (please see chapter 1.6.1 "UL and CSA approval").

### 7.2.1 Electrical data 1~115 V

Device model	SK 2x5E...	-250-112-	-370-112-	-550-112-	-750-112-		
	Size	1	1	2	2		
Rated motor power (4-pole standard motor)	230 V	0.25 kW	0.37 kW	0.55 kW	0.75 kW		
	240 V	1/3 hp	1/2 hp	3/4 hp	1 hp		
Line voltage	<b>115 V</b>	<b>1 AC 100 ... 120 V, ± 10%, 47 ... 63 Hz</b>					
Input current	rms <sup>1)</sup>	8.9 A	11.0 A	13.1 A	20.1 A		
	FLA <sup>2)</sup>	8.9 A	10.8 A	13.1 A	20.1 A		
Output voltage	<b>230 V</b>	<b>3 AC 0 ... 2 times line voltage</b>					
Output current <sup>3)</sup>	rms <sup>1)</sup>	1.7 A	2.2 A	3.0 A	4.0 A		
	FLA motor mounting <sup>2)</sup>	1.7 A	1.7 A	3.0 A	3.0 A		
	FLA wall mounting <sup>2)</sup>	1.7 A	2.1 A	3.0 A	4.0 A		
Min. braking resistance	Accessories	75 Ω	75 Ω	75 Ω	75 Ω		
<b>Motor-mounted (ventilated)</b>							
Max. continuous power/max. continuous current							
	S1-50°C	0.25 kW/1.6 A	0.25 kW/1.6 A	0.37 kW/2.6 A	0.37 kW/2.6 A		
	S1-40°C	0.25 kW/1.7 A	0.25 kW/1.8 A	0.55 kW/3.0 A	0.55 kW/3.0 A		
	S1-30°C	0.25 kW/1.7 A	0.37 kW/2.0 A	0.55 kW/3.0 A	0.55 kW/3.4 A		
Max. permissible ambient temp. with rated output current							
S1		47°C	23°C	40°C	11°C		
S3 70% ED 10 min		50°C	35°C	50°C	25°C		
S6 70% ED 10 min (100%/20% Mn)		50°C	30°C	45°C	20°C		
<b>Wall mounting (ventilated/unventilated)</b>							
Max. continuous power/max. continuous current							
	S1-50°C	0.25 kW/1.6 A	0.25 kW/1.6 A	0.55 kW/3.0 A	0.55 kW/3.0 A		
	S1-40°C	0.25 kW/1.7 A	0.37 kW/2.0 A	0.55 kW/3.0 A	0.55 kW/3.3 A		
	S1-30°C	0.25 kW/1.7 A	0.37 kW/2.1 A	0.55 kW/3.0 A	0.55 kW/3.6 A		
Max. permissible ambient temp. with nominal output current							
S1		48°C	36°C	50°C	16°C		
S3 70% ED 10 min		50°C	40°C	50°C	30°C		
S6 70% ED 10 min (100%/20% Mn)		50°C	40°C	50°C	25°C		
<b>General fuses (AC) (recommended)</b>							
slow-blowing		16 A	16 A	16 A	25 A		
		<b>UL-approved fuses (AC)</b>					
		Isc <sup>4)</sup> [A]					
		10 000	65 000	100 000			
Class							
Fuse <sup>5)</sup>	RK5	(x)	x	30 A	30 A	30 A	30 A
	CC, J, R, T, G, L	(x)	x	30 A	30 A	30 A	30 A
	Bussmann FRS-	(x)	x	<b>R-30</b>	<b>R-30</b>	<b>R-30</b>	<b>R-30</b>
CB <sup>6)</sup>	(≥ 115 V)		x	25 A	25 A	25 A	25 A

1) Pay attention to derating curve (see section 8.4.4 "Reduced output current due to line voltage").

2) FLA – **Full-load current**, maximum current for the entire line voltage range as stated above (100 V – 120 V) according to UL/CSA

3) FLA (S1-40°C), FLA motor mounting: relates to a motor with fans

4) Maximum permissible short-circuit current on grid

5) The use of an SK TU4-MSW(-...) module limits the permissible short circuit in the grid to 10 kA

6) "inverse time trip type" in acc. with UL 489

**7.2.2 Electrical data 1~230 V**

Device model	SK 2xxE...	-250-123-	-370-123-	-550-123-	-750-123-	-111-123-		
	Size	1	1	1	2 <sup>a)</sup>	2 <sup>a)</sup>		
Rated motor power (4-pole standard motor)	230 V	0.25 kW	0.37 kW	0.55 kW	0.75 kW	1.10 kW		
	240 V	1/3 hp	1/2 hp	3/4 hp	1 hp	1 1/2 hp		
Line voltage	<b>230 V</b>	<b>1 AC 200 ... 240 V, ± 10%, 47 ... 63 Hz</b>						
Input current	rms <sup>1)</sup>	3.9 A	5.8 A	7.3 A	10.2 A	14.7 A		
	FLA <sup>2)</sup>	3.9 A	5.8 A	7.3 A	10.1 A	14.6 A		
Output voltage	<b>230 V</b>	<b>3 AC 0 ... line voltage</b>						
Output current <sup>3), 4)</sup>	rms <sup>1)</sup>	1.7 A	2.2 A	3.0 A	4.0 A	5.5 A		
	FLA motor mounting <sup>2)</sup>	1.7 A	2.2 A	2.6 A	3.9 A	5.4 A		
	FLA wall mounting <sup>2)</sup>	1.7 A	2.2 A	2.9 A	3.9 A	4.4 A <sup>b)</sup>		
Min. braking resistance	Accessories	75 Ω	75 Ω	75 Ω	75 Ω	75 Ω		
<b>Motor mounting (ventilated)<sup>4)</sup></b>								
Max. continuous power/max. continuous current								
	S1-50°C	0.25kW/1.6A	0.25kW/1.8A	0.37kW/2.5A	0.55kW/3.4A	0.75kW/4.3A		
	S1-40°C	0.25kW/1.7A	0.37kW/2.0A	0.55kW/2.8A	0.55kW/3.7A	0.75kW/4.8A		
	S1-30°C	0.25kW/1.7A	0.37kW/2.2A	0.55kW/2.9A	0.75kW/4.0A	1.10kW/5.4A		
Max. permissible ambient temp. with nominal output current								
	S1	49°C	33°C	36°C	35°C	29°C		
	S3 70% ED 10 min	50°C	45°C	45°C	45°C	40°C		
	S6 70% ED 10 min (100%/20% Mn)	50°C	40°C	40°C	40°C	35°C		
<b>Wall mounting (ventilated/unventilated)<sup>4)</sup></b>								
Max. continuous power/max. continuous current								
	S1-50°C	0.25kW/1.5A	0.37kW/2.2A	0.37kW/2.7A	0.75kW/4.0A	0.75kW/4.3A		
	S1-40°C	0.25kW/1.7A	0.37kW/2.2A	0.55kW/2.9A	0.75kW/4.0A	0.75kW/4.8A		
	S1-30°C	0.25kW/1.7A	0.37kW/2.2A	0.55kW/2.9A	0.75kW/4.0A	1.10kW/5.3A		
Max. permissible ambient temp. with nominal output current								
	S1	44°C	50°C	42°C	50°C	27°C		
	S3 70% ED 10 min	50°C	50°C	45°C	50°C	40°C		
	S6 70% ED 10 min (100%/20% Mn)	45°C	50°C	45°C	50°C	35°C		
<b>General fuses (AC) (recommended)</b>								
slow-blowing		10 A	10 A	16 A	16 A	16 A		
		<b>UL-approved fuses (AC)</b>						
		Isc <sup>5)</sup> [A]						
		10 000	65 000	100 000				
Class								
Fuse <sup>6)</sup>	RK5	(x)	x	10 A	10 A	10 A	30 A	30 A
	CC, J, R, T, G, L	(x)	x	10 A	10 A	10 A	30 A	30 A
	Bussmann FRS-	(x)	x	<b>R-10</b>	<b>R-10</b>	<b>R-10</b>	<b>R-30</b>	<b>R-30</b>
CB <sup>7)</sup>	(≥ 230 V)		x	10 A	10 A	10 A	25 A	25 A

1) Pay attention to derating curve (see section 8.4.4 "Reduced output current due to line voltage").

2) FLA – **Full-load current**, maximum current for the entire line voltage range as stated above (200 V – 240 V) according to UL/CSA

3) FLA (S1-40°C), FLA motor mounting: relates to a motor with fans

4) SK 21xE and SK 23xE devices: For use of safe functions (functional safety: STO and SS1) the restrictions regarding the permissible temperature range according to [BU 0230](#) must be noted.

5) Maximum permissible short-circuit current in the grid

6) The use of an SK TU4-MSW(-...) module, limits the permissible short circuit in the grid to 10 kA

7) "inverse time trip type" in acc. with UL 489

a) Size 2: only SK 2x5E

a) 5.4 A when using a suitable fan

### 7.2.3 Electrical data 3~230 V

Device model	SK 2xxE...	-250-323-	-370-323-	-550-323-	-750-323-	-111-323-		
	Size	1	1	1	1	1		
Rated motor power (4-pole standard motor)	230 V	0.25 kW	0.37 kW	0.55 kW	0.75 kW	1.10 kW		
	240 V	1/3 hp	1/2 hp	3/4 hp	1 hp	1 1/2 hp		
Line voltage	<b>230 V</b>	<b>3 AC 200 ... 240 V, ± 10%, 47 ... 63 Hz</b>						
Input current	rms <sup>1)</sup>	1.4 A	1.9 A	2.6 A	3.5 A	5.1 A		
	FLA <sup>2)</sup>	1.4 A	1.9 A	2.6 A	3.5 A	5.1 A		
Output voltage	<b>230 V</b>	<b>3 AC 0 ... line voltage</b>						
Output current <sup>3), 4)</sup>	rms <sup>1)</sup>	1.7 A	2.2 A	3.0 A	4.0 A	5.5 A		
	FLA motor mounting <sup>2)</sup>	1.7 A	2.2 A	2.9 A	3.9 A	5.4 A		
	FLA wall mounting <sup>2)</sup>	1.7 A	2.2 A	2.9 A	3.9 A (S1-40°C)	4.0 A <sup>a)</sup> (S1-40°C)		
Min. braking resistance	Accessories	100 Ω	100 Ω	100 Ω	100 Ω	100 Ω		
<b>Motor-mounted (ventilated), or wall mounting with SK TIE4-WMK-L-1 (ventilated) <sup>4)</sup></b>								
Max. continuous power/max. continuous current								
		S1-50°C	0.25kW/1.7A	0.37kW/2.2A	0.55kW/3.0A	0.75kW/4.0A	1.1kW/5.5A	
Max. permissible ambient temp. with nominal output current								
S1		50°C	50°C	50°C	50°C	50°C		
S3 70% ED 10 min		50°C	50°C	50°C	50°C	50°C		
S6 70% ED 10 min (100%/20% Mn)		50°C	50°C	50°C	50°C	50°C		
<b>Wall mounting (unventilated) <sup>4)</sup></b>								
Max. continuous power/max. continuous current								
S1-50°C		0.25kW/1.7A	0.37kW/2.2A	0.55kW/2.8A	0.55kW/2.8A	0.55kW/3.4A		
S1-40°C		0.25kW/1.7A	0.37kW/2.2A	0.55kW/3.0A	0.55kW/3.5A	0.75kW/4.2A		
S1-30°C		0.25kW/1.7A	0.37kW/2.2A	0.55kW/3.0A	0.75kW/4.0A	0.75kW/4.8A		
Max. permissible ambient temp. with nominal output current								
S1		50°C	50°C	48°C	32°C	20°C		
S3 70% ED 10 min		50°C	50°C	50°C	40°C	30°C		
S6 70% ED 10 min (100%/20% Mn)		50°C	50°C	50°C	35°C	25°C		
<b>General fuses (AC) (recommended)</b>								
slow-blowing		10 A	10 A	10 A	10 A	16 A		
Class		<b>UL-approved fuses (AC)</b>						
		Isc <sup>5)</sup> [A]	10 000	65 000	100 000			
Fuse <sup>6)</sup>	RK5	(x)	x	5 A	5 A	10 A	10 A	10 A
	CC, J, R, T, G, L	(x)	x	5 A	5 A	10 A	10 A	10 A
	Bussmann FRS-	(x)	x	<b>R-5</b>	<b>R-5</b>	<b>R-10</b>	<b>R-10</b>	<b>R-10</b>
CB <sup>7)</sup>	(≥ 230 V)		x	5 A	5 A	10 A	10 A	10 A

1) Pay attention to derating curve (see section 8.4.4 "Reduced output current due to line voltage").

2) FLA – **Full-load current**, maximum current for the entire line voltage range as stated above (200 V – 240 V) according to UL/CSA

3) FLA (S1-45°C), FLA motor mounting: relates to a motor with fans

4) SK 21xE and SK 23xE devices: For use of safe functions (functional safety: STO and SS1) the restrictions regarding the permissible temperature range according to [BU 0230](#) must be noted.

5) Maximum permissible short-circuit current in the grid

6) The use of an SK TU4-MSW(-...) module, limits the permissible short circuit in the grid to 10 kA

7) "inverse time trip type" in acc. with UL 489

a) 5.4 A when using a suitable fan



Device model	SK 2xxE...	-151-323-	-221-323-	-301-323-	-401-323-			
	Size	2	2	3	3			
Rated motor power (4-pole standard motor)	230 V	1.5 kW	2.2 kW	3.0 kW	4.0 kW			
	240 V	2 hp	3 hp	4 hp	5 hp			
Line voltage	<b>230 V</b>	<b>3 AC 200 ... 240 V, ± 10%, 47 ... 63 Hz</b>						
Input current	rms <sup>1)</sup>	6.6 A	9.1 A	11.8 A	15.1 A			
	FLA <sup>2)</sup>	6.6 A	9.1 A	11.7 A	14.9 A			
Output voltage	<b>230 V</b>	<b>3 AC 0 ... line voltage</b>						
Output current <sup>3), 4)</sup>	rms <sup>1)</sup>	7.0 A	9.5 A	12.5 A	16.0 A			
	FLA motor mounting <sup>2)</sup>	6.9 A	8.8 A	12.3 A	15.7 A			
	FLA wall mounting <sup>2)</sup>	5.5 A <sup>a)</sup> (S1-40°C)	5.5 A <sup>b)</sup> (S1-40°C)	8.0 A <sup>c)</sup> (S1-40°C)	8.0 A <sup>d)</sup> (S1-40°C)			
Min. braking resistance	Accessories	62 Ω	62 Ω	33 Ω	33 Ω			
<b>Motor mounting (ventilated), or wall mounting with SK TIE4-WMK-L-1 (or -2) (ventilated) <sup>4)</sup></b>								
Max. continuous power/max. continuous current								
	S1-50°C	1.5kW/7.0A	1.5kW/9.2A	3.0kW/12.5A	3.0kW/14.5A			
	S1-40°C	1.5kW/7.0A	2.2kW/9.5A	3.0kW/12.5A	4.0kW/16.0A			
Max. permissible ambient temp. with rated output current								
S1		50°C	49°C	50°C	46°C			
S3 70% ED 10 min		50°C	50°C	50°C	47°C			
S6 70% ED 10 min (100%/20% Mn)		50°C	50°C	50°C	47°C			
<b>Wall mounting (unventilated) <sup>4)</sup></b>								
Max. continuous power/max. continuous current								
	S1-50°C	0.55kW/3.8A	0.75kW/4.7A	1.1kW/6.8A	1.1kW/6.8A			
	S1-40°C	0.75kW/4.8A	1.10kW/5.8A	1.5kW/8.7A	1.5kW/8.7A			
	S1-30°C	1.10kW/5.7A	1.50kW/6.7A	2.2kW/10.4A	2.2kW/10.4A			
Max. permissible ambient temp. with nominal output current								
S1		15°C	6°C	18°C	-4°C			
S3 70% ED 10 min		25°C	20°C	30°C	0°C			
S6 70% ED 10 min (100%/20% Mn)		20°C	10°C	25°C	0°C			
		<b>General fuses (AC) (recommended)</b>						
slow-blowing		16 A	20 A	20 A	25 A			
		<b>UL-approved fuses (AC)</b>						
		Isc <sup>5)</sup> [A]						
		10 000	65 000	100 000				
Class								
Fuse <sup>6)</sup>	RK5	(x)		x	10 A	30 A	30 A	30 A
	CC, J, R, T, G, L	(x)		x	10 A	30 A	30 A	30 A
	Bussmann FRS-	(x)		x	<b>R-10</b>	<b>R-30</b>	<b>R-30</b>	<b>R-30</b>
CB <sup>7)</sup>	(≥ 230 V)		x		10 A	25 A	25 A	25 A

1) Pay attention to derating curve (☞ section 8.4.4 "Reduced output current due to line voltage").

2) FLA – **Full-load current**, maximum current for the entire line voltage range as stated above (200 V – 240 V) according to UL/CSA

3) FLA (S1-45°C), FLA motor mounting: relates to a motor with fans

4) SK 21xE and SK 23xE devices: For use of safe functions (functional safety: STO and SS1) the restrictions regarding the permissible temperature range according to [BU 0230](#) must be noted.

5) Maximum permissible short-circuit current in the grid

6) The use of an SK TU4-MSW(...) module limits the permissible short circuit in the grid to 10 kA

7) "inverse time trip type" in acc. with UL 489

- a) 6.9 A when using a suitable fan
- a) 8.8 A when using a suitable fan
- a) 12.3 A when using a suitable fan
- a) 15.7 A when using a suitable fan

Device model	SK 2xxE...	-551-323-	-751-323-	-112-323-		
	Size	4	4	4		
Rated motor power (4-pole standard motor)	230 V	5.5 kW	7.5 kW	11.0 kW		
	240 V	7 ½ hp	10 hp	15 hp		
Line voltage	<b>230 V</b>	<b>3 AC 200 ... 240 V, ± 10%, 47 ... 63 Hz</b>				
Input current	rms <sup>1)</sup>	23.5 A	29.5 A	40.5 A		
	FLA <sup>2)</sup>	22.5 A	28.5 A	39.5 A		
Output voltage	<b>230 V</b>	<b>3 AC 0 ... line voltage</b>				
Output current <sup>3), 4)</sup>	rms <sup>1)</sup>	23.0 A	29.0 A	40.0 A		
	FLA motor mounting <sup>2)</sup>	22.0 A	28.0 A	39.0 A		
	FLA wall mounting <sup>2)</sup>	22.0 A	28.0 A	39.0 A		
Min. braking resistance	Accessories	30 Ω	20 Ω	15 Ω		
<b>Motor mounting (fan cooling 5), integrated in device) <sup>4)</sup></b>						
Max. continuous power/max. continuous current						
	S1-40°C	5.5kW/23.0A	7.5kW/29.0A	11.0kW/40.0A		
Max. permissible ambient temp. with nominal output current						
S1		40°C	40°C	40°C		
S3 70% ED 10 min		50°C	50°C	44°C		
S6 70% ED 10 min (100%/20% Mn)		47°C	50°C	44°C		
<b>Wall mounting (fan cooling 5), integrated in device) <sup>4)</sup></b>						
Max. continuous power/max. continuous current						
	S1-40°C	5.5kW/23.0A	7.5kW/29.0A	11.0kW/40.0A		
Max. permissible ambient temp. with nominal output current						
S1		45°C	45°C	45°C		
S3 70% ED 10 min		50°C	50°C	47°C		
S6 70% ED 10 min (100%/20% Mn)		50°C	50°C	47°C		
		<b>General fuses (AC) (recommended)</b>				
slow-blowing		35 A	50 A	50 A		
		<b>UL-approved fuses (AC)</b>				
		Isc <sup>6)</sup> [A]				
Class		10 000	65 000	100 000		
Fuse	CC, J, R, T, G, L (300 V)		x		60 A	60 A
CB <sup>7)</sup>	(300 V)	x			60 A	60 A

1) Pay attention to derating curve (see section 8.4.4 "Reduced output current due to line voltage").

2) FLA – **Full-load current**, maximum current for the entire line voltage range as stated above (200 V – 240 V) according to UL/CSA

3) FLA (S1-40°C)

4) SK 21xE and SK 23xE devices: For use of safe functions (functional safety: STO and SS1) the restrictions regarding the permissible temperature range according to [BU 0230](#) must be noted.

5) Fan cooling, temperature-controlled: ON= 55°C, OFF= 50°C,  
After-run time when 50°C limit undershot and enable removed: 2 minutes

6) Maximum permissible mains short circuit current

7) "inverse time trip type" in acc. with UL 489

**7.2.4 Electrical data 3~400 V**

Device model	SK 2xxE...	-550-340-	-750-340-	-111-340-	-151-340-	-221-340-		
	Size	1	1	1	1	1		
Rated motor power (4-pole standard motor)	400 V	0.55 kW	0.75 kW	1.1 kW	1.5 kW	2.2 kW		
	480 V	¾ hp	1 hp	1½ hp	2 hp	3 hp		
Line voltage	<b>400 V</b>	<b>3 AC 380 V ... 500 V, - 20%/+10%, 47 Hz ... 63 Hz</b>						
Input current	rms <sup>1)</sup>	1.6 A	2.2 A	2.9 A	3.7 A	5.2 A		
	FLA <sup>2)</sup>	1.4 A	2.0 A	2.7 A	3.4 A	4.7 A		
Output voltage	<b>400 V</b>	<b>3 AC 0 ... line voltage</b>						
Output current <sup>3), 4)</sup>	rms <sup>1)</sup>	1.7 A	2.3 A	3.1 A	4.0 A	5.5 A		
	FLA motor mounting <sup>2)</sup>	1.5 A	2.1 A	2.8 A	3.6 A	4.9 A		
	FLA wall mounting <sup>2)</sup>	1.5 A	2.1 A	2.8 A	3.6 A (S1-40°C)	4.0 A <sup>a)</sup> (S1-40°C)		
Min. brake resistance	Accessories	200 Ω	200 Ω	200 Ω	200 Ω	200 Ω		
<b>Motor-mounted (ventilated), or wall mounting with SK TIE4-WMK-L-1 (ventilated) <sup>4)</sup></b>								
Max. continuous power/max. continuous current								
S1-50°C		0.55kW/1.7A	0.75kW/2.3A	1.1kW/3.1A	1.5kW/4.0A	2.2kW/5.5A		
Max. permissible ambient temp. with nominal output current								
S1		50°C	50°C	50°C	50°C	50°C		
S3 70% ED 10 min		50°C	50°C	50°C	50°C	50°C		
S6 70% ED 10 min (100%/20% Mn)		50°C	50°C	50°C	50°C	50°C		
<b>Wall mounting (unventilated) <sup>4)</sup></b>								
Max. continuous power/max. continuous current								
S1-50°C		0.55kW/1.7A	0.75kW/2.3A	0.75kW/2.8A	0.75kW/2.8A	0.75kW/2.8A		
S1-40°C		0.55kW/1.7A	0.75kW/2.3A	1.1kW/3.1A	1.1kW/3.3A	1.1kW/3.3A		
S1-30°C		0.55kW/1.7A	0.75kW/2.3A	1.1kW/3.1A	1.5kW/3.9A	1.5kW/3.9A		
Max. permissible ambient temp. with nominal output current								
S1		50°C	50°C	45°C	29°C	1°C		
S3 70% ED 10 min		50°C	50°C	50°C	40°C	15°C		
S6 70% ED 10 min (100%/20% Mn)		50°C	50°C	50°C	35°C	5°C		
<b>General fuses (AC) (recommended)</b>								
slow-blowing		10 A	10 A	10 A	10 A	10 A		
Class		<b>UL-approved fuses (AC)</b>						
		Isc <sup>5)</sup> [A]						
Fuse <sup>6)</sup>	RK5	(x)	x	5 A	5 A	10 A	10 A	10 A
	CC, J, R, T, G, L	(x)	x	5 A	5 A	10 A	10 A	10 A
	Bussmann <b>FRS-</b>	(x)	x	<b>R-5</b>	<b>R-5</b>	<b>R-10</b>	<b>R-10</b>	<b>R-10</b>
CB <sup>7)</sup>	(≥ 230 / 400 V)		x	5 A	5 A	10 A	10 A	10 A

1) Pay attention to derating curve (see section 8.4.4 "Reduced output current due to line voltage").

2) FLA – **Full-load current**, maximum current for the entire line voltage range as stated above (380 V – 500 V) according to UL/CSA

3) FLA (S1-45°C), FLA motor mounting: relates to a motor with fans

4) SK 21xE and SK 23xE devices: For use of safe functions (functional safety: STO and SS1) the restrictions regarding the permissible temperature range according to [BU 0230](#) must be noted.

5) Maximum permissible short-circuit current in the grid

6) The use of an SK TU4-MSW(-...) module, limits the permissible short circuit in the grid to 10 kA

7) "inverse time trip type" in acc. with UL 489

a) 4.9 A when using a suitable fan

Device model	SK 2xxE...	-301-340-	-401-340-	-551-340-	-751-340-		
	Size	2	2	3	3		
Rated motor power (4-pole standard motor)	400 V	3.0 kW	4.0 kW	5.5 kW	7.5 kW		
	480 V	4 hp	5 hp	7 ½ hp	10 hp		
Line voltage	400 V	3 AC 380 ... 500 V, -20%/+10%, 47 Hz ... 63 Hz					
Input current	rms <sup>1)</sup>	7.0 A	8.9 A	11.7 A	15.0 A		
	FLA <sup>2)</sup>	6.3 A	8.0 A	10.3 A	13.1 A		
Output voltage	400 = 0 – 10 V	3 AC 0 ... line voltage					
Output current <sup>3), 4)</sup>	rms <sup>1)</sup>	7.5 A	9.5 A	12.5 A	16.0 A		
	FLA motor mounting <sup>2)</sup>	6.7 A	8.5 A	11.0 A	14.0 A		
	FLA wall mounting <sup>2)</sup>	5.5 <sup>a)</sup> A (S1-40°C)	5.5 <sup>b)</sup> A (S1-40°C)	8.0 <sup>c)</sup> A (S1-40°C)	8.0 <sup>d)</sup> A (S1-40°C)		
Min. brake resistance	Accessories	110 Ω	110 Ω	68 Ω	68 Ω		
<b>Motor mounting (ventilated), or wall mounting with SK TIE4-WMK-L-1 (or -2) (ventilated) <sup>4)</sup></b>							
Max. continuous power/max. continuous current:							
	S1-50°C	2.2kW/5.5A	3.0kW/8.0A	4.0kW/11.8A	5.5kW/13.8A		
	S1-40°C	3.0kW/7.5A	4.0kW/9.5A	5.5kW/12.5A	7.5kW/16.0A		
Max. permissible ambient temp. with rated output current							
	S1	43°C	41°C	48°C	43°C		
	S3 70% ED 10 min	45°C	45°C	50°C	45°C		
	S6 70% ED 10 min (100%/20% Mn)	45°C	41°C	50°C	45°C		
<b>Wall mounting (unventilated) <sup>4)</sup></b>							
Max. continuous power/max. continuous current:							
	S1-50°C	1.1kW/3.1A	1.5kW/4.0A	1.5kW/5.3A	2.2kW/6.3A		
	S1-40°C	1.5kW/4.0A	1.5kW/4.9A	2.2kW/6.9A	3.0kW/7.9A		
	S1-30°C	1.5kW/4.8A	2.2kW/5.7A	3.0kW/8.4A	4.0kW/9.4A		
Max. permissible ambient temp. with nominal output current							
	S1	-3°C	-20°C	1°C	-18°C		
	S3 70% ED 10 min	0°C	-5°C	15°C	-5°C		
	S6 70% ED 10 min (100%/20% Mn)	0°C	-15°C	5°C	-10°C		
<b>General fuses (AC) (recommended)</b>							
slow-blowing		16 A	16 A	20 A	25 A		
		<b>UL-approved fuses (AC)</b>					
		Isc <sup>5)</sup> [A]					
		10 000	65 000	100 000			
Class							
Fuse <sup>6)</sup>	RK5	(x)	x	10 A	30 A	30 A	30 A
	CC, J, R, T, G, L	(x)	x	10 A	30 A	30 A	30 A
	Bussmann <b>FRS-</b>	(x)	x	<b>R-10</b>	<b>R-30</b>	<b>R-30</b>	<b>R-30</b>
CB <sup>7)</sup>	(≥ 230 / 400 V)		x	10 A	25 A	25 A	25 A

1) Pay attention to derating curve (☞ section 8.4.4 "Reduced output current due to line voltage").

2) FLA – **Full-load current**, maximum current for the entire line voltage range as stated above (380 V – 500 V) according to UL/CSA

3) FLA (S1-45°C), FLA motor mounting: relates to a motor with fans

4) SK 21xE and SK 23xE devices: For use of safe functions (functional safety: STO and SS1) the restrictions regarding the permissible temperature range according to [BU 0230](#) must be noted.

5) Maximum permissible short-circuit current in the grid

6) The use of an SK TU4-MSW(-...) module, limits the permissible short circuit in the grid to 10 kA

7) "inverse time trip type" in acc. with UL 489

- a) 6.7 A when using a suitable fan
- a) 8.5 A when using a suitable fan
- a) 11.0 A when using a suitable fan
- a) 14.0 A when using a suitable fan

Device model	SK 2xxE...	-112-340-	-152-340-	-182-340-	-222-340-			
	<b>Size</b>	<b>4</b>	<b>4</b>	<b>4</b>	<b>4</b>			
Rated motor power (4-pole standard motor)	400 V	11.0 kW	15.0 kW	18.5 kW	22.0 kW			
	480 V	15 hp	20 hp	25 hp	30 hp			
Line voltage	<b>400 = 0 – 10 V</b>	<b>3 AC</b> 380 V ... 500 V, -20%/+10%, 47 Hz ... 63 Hz						
Input current	rms <sup>1)</sup>	23.6 A	32.0 A	40.5 A	46.5 A			
	FLA <sup>2)</sup>	20.5 A	28.0 A	35.5 A	42.5 A			
Output voltage	<b>400 = 0 – 10 V</b>	<b>3 AC</b> 0 ... line voltage						
Output current <sup>3), 4)</sup>	rms <sup>1)</sup>	23.0 A	32.0 A	40.0 A	46.0 A			
	FLA motor mounting <sup>2)</sup>	20.0 A	28.0 A	35.0 A	42.0 A			
	FLA wall mounting <sup>2)</sup>	20.0 A	28.0 A	35.0 A	42.0 A			
Min. braking resistance	Accessories	47 Ω	33 Ω	27 Ω	24 Ω			
<b>Motor mounting (fan cooling 5), integrated in device) <sup>4)</sup></b>								
Max. continuous power/max. continuous current								
	S1-40°C	11.0kW/23.0A	15.0kW/32.0A	18.5kW/40.0A	22.0kW/46.0A			
Max. permissible ambient temp. with nominal output current								
	S1	40°C	40°C	40°C	40°C			
	S3 70% ED 10 min	50°C	49°C	41°C	41°C			
	S6 70% ED 10 min (100%/20% Mn)	50°C	49°C	41°C	41°C			
<b>Wall mounting (fan cooling 5), integrated in device) <sup>4)</sup></b>								
Max. continuous power/max. continuous current								
	S1-40°C	11.0kW/23.0A	15.0kW/32.0A	18.5kW/40.0A	22.0kW/46.0A			
Max. permissible ambient temp. with rated output current								
	S1	45°C	45°C	41°C	40°C			
	S3 70% ED 10 min	50°C	50°C	43°C	42°C			
	S6 70% ED 10 min (100%/20% Mn)	50°C	50°C	43°C	41°C			
<b>General fuses (AC) (recommended)</b>								
	slow-blowing	35 A	50 A	50 A	63 A			
		<b>UL-approved fuses (AC)</b>						
		Isc <sup>6)</sup> [A]						
		10 000	65 000	100 000				
Class								
CB <sup>7)</sup> Fuse	CC, J, R, T, G, L (600 V)		x		60 A	60 A	60 A	60 A
	(600 V)	x			60 A	60 A	60 A	60 A

1) Pay attention to derating curve (☞ section 8.4.4 "Reduced output current due to line voltage").

2) FLA – **Full Load Current**, maximum current for the entire line voltage range as stated above (380 V – 500 V) according to UL/CSA

3) FLA (S1-40°C)

4) SK 21xE and SK 23xE devices: For use of safe functions (functional safety: STO and SS1) the restrictions regarding the permissible temperature range according to [BU 0230](#) must be noted.

5) Fan cooling, temperature-controlled: ON= 55°C, OFF= 50°C,  
After-run time when 50°C limit undershot and enable removed: 2 minutes

6) Maximum permissible short-circuit current in the grid

7) "inverse time trip type" in acc. with UL 489

## 8 Additional information

### 8.1 Setpoint processing

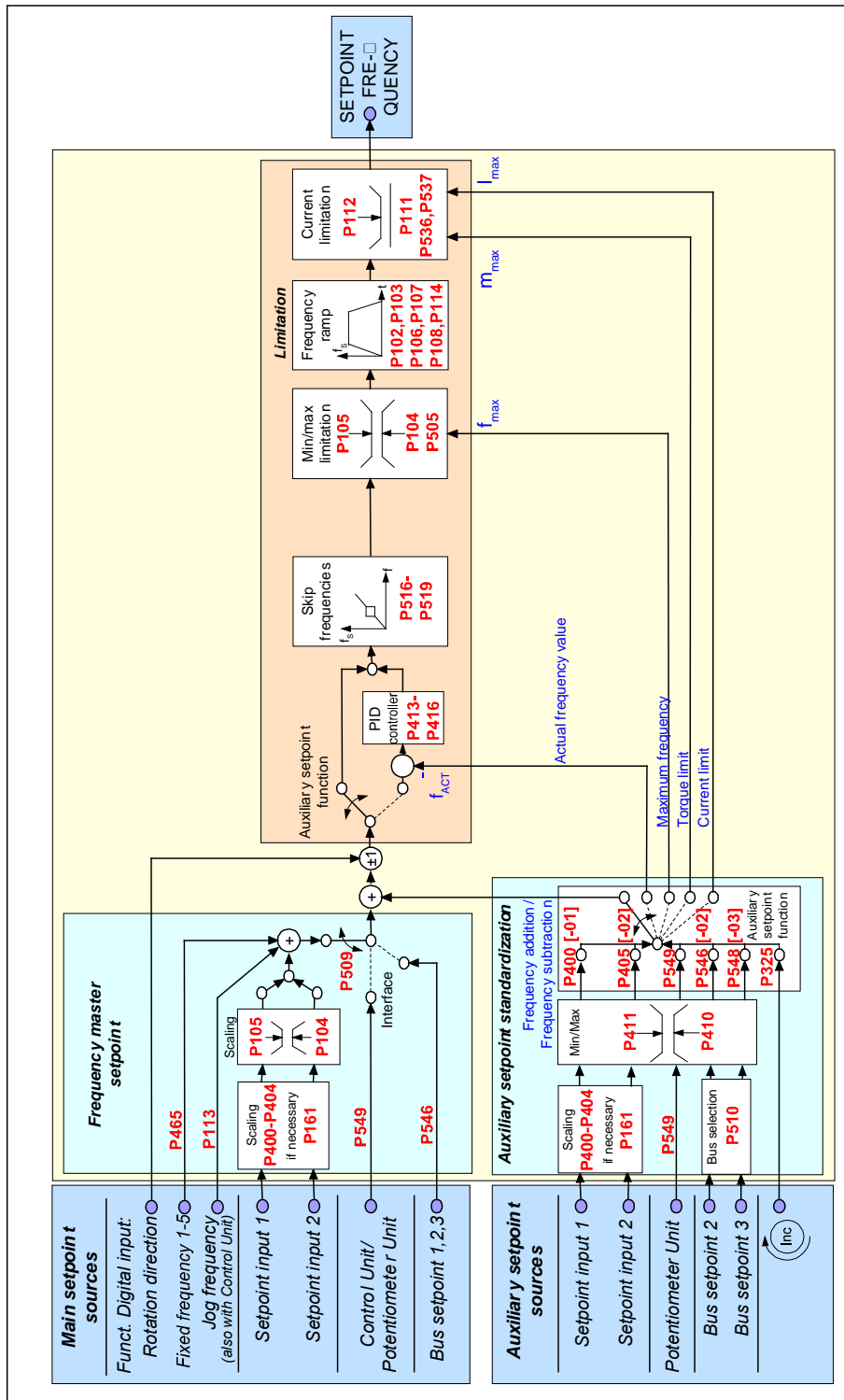

Figure 31: Setpoint processing

### 8.2 Process controller

The process controller is a PI controller which can be used to limit the controller output. In addition, the output is scaled as a percentage of a master setpoint. This provides the option of controlling any downstream drives with the master setpoint and readjusting using the PI controller.

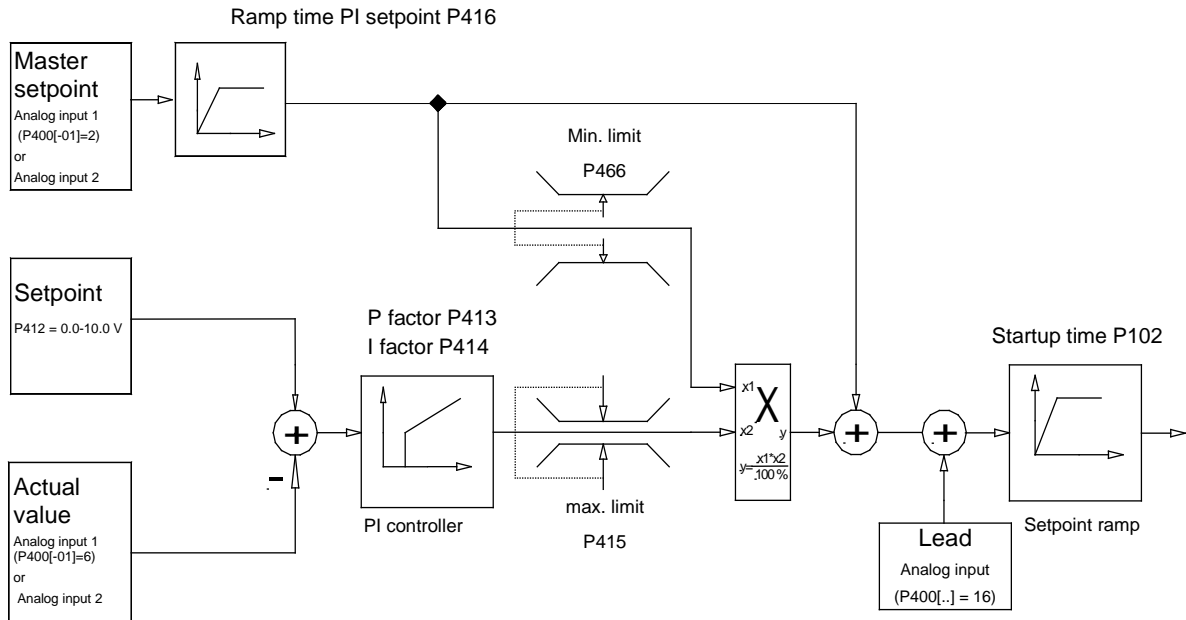
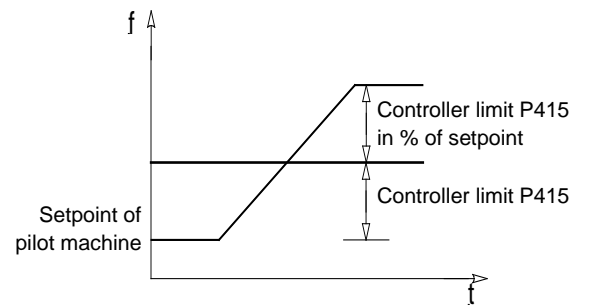
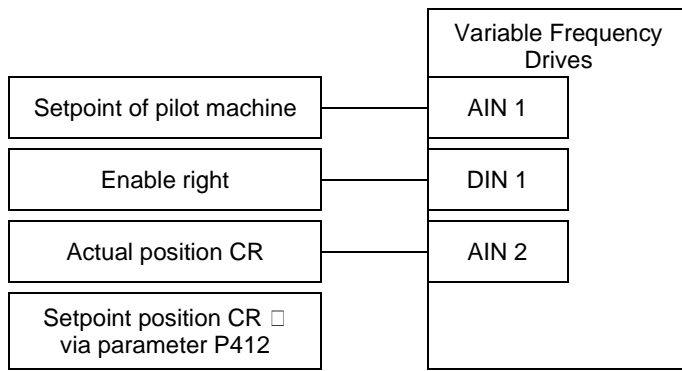
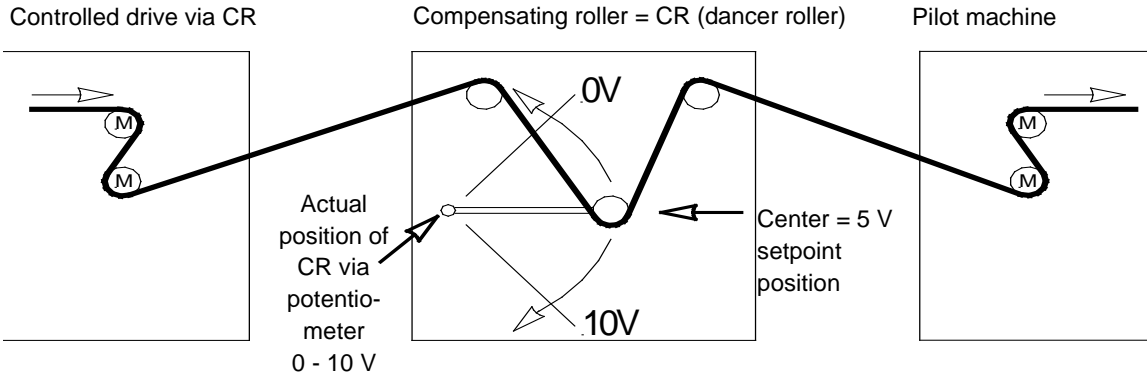

Figure 32: Process controller flow diagram

### 8.2.1 Process controller application example





### 8.2.2 Process controller parameter settings

(Example: SK 2x0E Setpoint frequency: 50 Hz, control limits: +/- 25%)

P105 (maximum frequency) [Hz] :  $\geq \text{Setpoint freq. [Hz]} + \left( \frac{\text{Setpoint freq. [Hz]} \times \text{P415 [%]}}{100\%} \right)$

Example:  $\geq 50\text{Hz} + \frac{50\text{Hz} \times 25\%}{100\%} = \mathbf{62.5\text{ Hz}}$

P400 [-01] (funct. analog input 1) : "2" = frequency addition)

P411 (setpoint frequency) [Hz] : Setpoint frequency at 10 V at analog input 1

Example: **50 Hz**

P412 (Process controller setpoint) : CR middle position/default setting **5 V** (adjust if necessary)

P413 (P controller) [%] : Factory setting **10%** (adjust if necessary)

P414 (I controller) [%/ms] : recommended **100%/s**

P415 (limitation +/-) [%] : Controller limitation (see above)

**Note:** Parameter P415 is used as a control limit after the PI controller.

Example: **25%** of setpoint

P416 (Ramp time PI setpoint) [s] : Factory setting **2 s** (if necessary, adjust to match controller behavior)

P420 [-01] funct.. digital input 1) : "1" Enable right

P400 [-02] (funct. analog input 2) : "6" PI process controller actual value

## 8.3 Electromagnetic compatibility (EMC)

If the device is installed according to the recommendations in this manual, it meets all EMC directive requirements as per the EMC product standard EN 61800-3.

### 8.3.1 General Provisions

As of July 2007, all electrical equipment which has an intrinsic, independent function and which is sold as an individual unit for end users, must comply with Directive 2004/108/EEC (formerly Directive EEC/89/336). There are three different ways for manufacturers to indicate compliance with this directive:

#### 1. *EU Declaration of Conformity*

This is a declaration from the manufacturer, stating that the requirements in the applicable European standards for the electrical environment of the equipment have been met. Only those standards which are published in the Official Journal of the European Community may be cited in the manufacturer's declaration.

#### 2. *Technical documentation*

Technical documentation can be produced which describes the EMC characteristics of the device. This documentation must be authorized by one of the "Responsible bodies" named by the responsible European government. This makes it possible to use standards which are still in preparation.

#### 3. *EU Type Test Certificate*

This method only applies to radio transmitter equipment.

The devices only have an intrinsic function when they are connected to other equipment (e.g. to a motor). The base units cannot therefore carry the CE mark that would confirm compliance with the EMC directive. Precise details are therefore given below about the EMC behavior of this product, based on the proviso that it is installed according to the guidelines and instructions described in this documentation.

The manufacturer can certify that his equipment meets the requirements of the EMC directive in the relevant environment with regard to their EMC behavior in power drives. The relevant limit values correspond to the basic standards EN 61000-6-2 and EN 61000-6-4 for interference immunity and interference emissions.

### 8.3.2 EMC evaluation

Two standards must be observed when evaluating electromagnetic compatibility.

#### 1. EN 55011-1 (environmental standard)

The limits are defined in dependence on the basic environment in which the product is operated in this standard. A distinction is made between 2 environments, whereby the **1st environment** describes the non-industrial **living and business area** without its own high-voltage or medium-voltage distribution transformers. The **2nd environment**, on the other hand, defines **industrial areas** which are not connected to the public low-voltage network, but have their own high-voltage or medium-voltage distribution transformers. The limits are subdivided into **classes A1, A2 and B**.

#### 2. EN 61800-3 (product standard)

The limits are defined in dependence on the usage area of the product in this standard. The limits are subdivided into into **categories C1, C2, C3 and C4**, whereby class C4 basically only applies to drive systems with higher voltage ( $\geq 1000$  V AC), or higher currents ( $\geq 400$  A). However, class C4 can also apply to the individual device if it is incorporated in complex systems.

The same limits apply to both standards: However, the standards differ with regard to an application that is extended in the product standard. The user decides which of the two standards applies, whereby the environmental standard applies in the event of a typical fault remedy.

The main connection between the two standards is explained as follows:

Category as per EN 61800-3	C1	C2	C3
Limit class in accordance with EN 55011	B	A1	A2
Operation permissible in			
1. Environment (living environment)	X	X <sup>1)</sup>	-
2. Environment (industrial environment)	X	X <sup>1)</sup>	X <sup>1)</sup>
Note required in accordance with EN-61800-3	-	2)	3)
Sales channel	Generally available	Limited availability	
EMC situation	No requirements	Installation and start-up by EMC expert	
1) Device used neither as a plug-in device nor in moving equipment 2) "The drive system can cause high-frequency interference in a living environment that may make interference suppression measures necessary". 3) "The drive system is not intended for use in a public low-voltage network that feeds residential areas".			

**Table 15: EMC comparison between EN 61800-3 and EN 55011**

### 8.3.3 EMC of device

## NOTICE

#### EMC interference to the environment

This device produces high-frequency interference which may make additional suppression measures necessary in domestic environments (📖 Section 8.3.2 "EMC evaluation").

- Use of shielded motor cables is essential in order to comply with the specified radio interference suppression level.

The device is exclusively intended for commercial use. It is therefore not subject to the requirements of standard EN 61000-3-2 for transmission of harmonics.

The limit value classes are only achieved if

- the wiring is EMC-compliant
- the length of the shielded motor cable does not exceed the permissible limits
- the standard pulse frequency (P504) is used

The motor cable shielding must be attached at both sides in the motor terminal box and the inverter housing in case of wall mounting.

Device model max. Motor cable, shielded	Jumper position (chapter 2.4.2.1)	Conducted emissions 150 kHz - 30 MHz	
		Class C2	Class C1
Device motor-mounted	Jumper set (CY=ON)	+	-
Device wall-mounted	Jumper set (CY=ON)	5 m	-

EMC Overview of standards which as per EN 61800-3 are used as test and measuring methods:		
<i>Emitted interference</i>		
Cable-related emission (interference voltage)	EN 55011	C2 -
Radiated emission (interference field strength)	EN 55011	C2 -
<i>Interference immunity EN 61000-6-1, EN 61000-6-2</i>		
ESD, discharge of static electricity	EN 61000-4-2	6 kV (CD), 8 kV (AD)
EMF, high-frequency electromagnetic fields	EN 61000-4-3	10 V/m; 80 – 1000 MHz 3 V/m; 1400 – 2700 MHz
Burst on control cables	EN 61000-4-4	1 kV
Burst on power and motor cables	EN 61000-4-4	2 kV
Surge (phase-phase/phase-ground)	EN 61000-4-5	1 kV/2 kV
Cable-led interference due to high-frequency fields	EN 61000-4-6	10 V, 0.15 – 80 MHz
Voltage fluctuations and drops	EN 61000-2-1	+10%, -15%; 90%
Voltage asymmetries and frequency changes	EN 61000-2-4	3%; 2%

Table 16: Overview according to product standard EN 61800-3

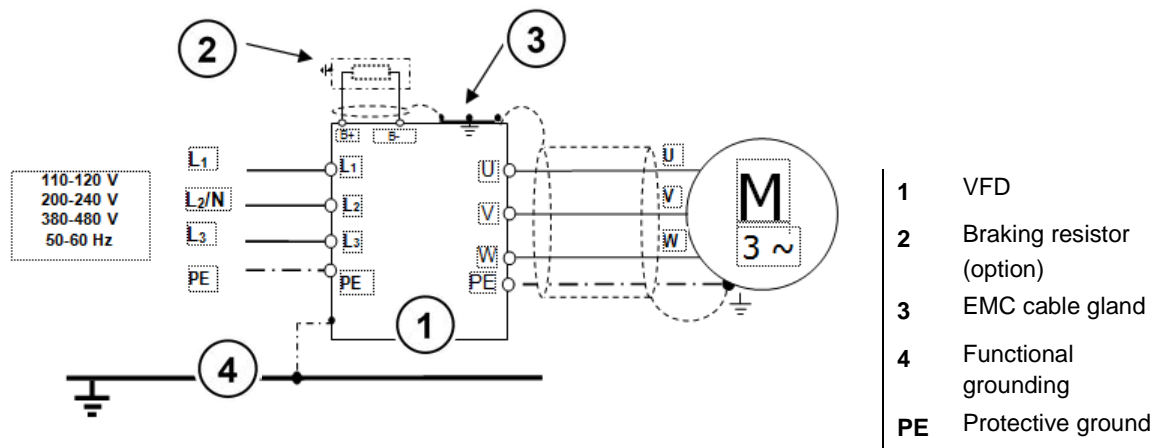





Figure 33: Wiring recommendation

### 8.3.4 EU Declaration of Conformity

<h2 style="margin: 0;">GETRIEBEBAU NORD</h2> <p style="margin: 0;">Member of the NORD DRIVESYSTEMS Group</p>																			
<p><b>Getriebebau NORD GmbH &amp; Co. KG</b>                  Getriebebau-Nord-Str. 1 . 22941 Bargtheide, Germany . Fon +49(0)4532 289 - 0 . Fax +49(0)4532 289 - 2253 . info@nord.com <span style="float: right;">C310700_2219</span></p>																			
<h3 style="margin: 0;">EU Declaration of Conformity</h3> <p style="margin: 0; font-size: x-small;">In the meaning of the directive 2014/35/EU Annex IV, 2014/30/EU Annex II and 2011/65/EU Annex VI</p>																			
<p>Getriebebau NORD GmbH &amp; Co. KG as manufacturer in sole responsibility hereby declares, <span style="float: right;">Page 1 of 1</span>                  that the variable speed drives from the product series</p> <ul style="list-style-type: none"> <li>• <b>SK 200E-xxx-123-B-.. , SK 200E-xxx-323-.-.. , SK 200E-xxx-340-.-..</b>                      (xxx= 250, 370, 550, 750, 111, 151, 221, 301, 401, 551, 751, 112, 152, 182, 222)                      also in these functional variants:  <b>SK 205E-..., SK 210E-..., SK 215E-..., SK 220E-..., SK 225E-..., SK 230E-..., SK 235E-...</b>                      and the further options/accessories:  <b>SK CU4-..., SK TU4-..., SK TI4-..., SK TIE4-..., SK BRI4-..., SK BRE4-...,</b>  <b>SK PAR-3. , SK CSX-3. , SK SSX-3A, SK POT1-., SK EPG-3H, SK TIE5-BT-STICK</b></li> </ul> <p>comply with the following regulations:</p> <table style="width: 100%; border: none;"> <tr> <td style="width: 30%;"><b>Low Voltage Directive</b></td> <td style="width: 20%;"><b>2014/35/EU</b></td> <td style="width: 50%;">OJ. L 96 of 29.3.2014, p. 357–374</td> </tr> <tr> <td><b>EMC Directive</b></td> <td><b>2014/30/EU</b></td> <td>OJ. L 96 of 29.3.2014, p. 79–106</td> </tr> <tr> <td><b>RoHS Directive</b></td> <td><b>2011/65/EU</b></td> <td>OJ. L 174 of 1.7.2011, p. 88–11</td> </tr> <tr> <td><b>Delegated Directive(EU)</b></td> <td><b>2015/863</b></td> <td>OJ. L 137 of 4.6.2015, p. 10–12</td> </tr> </table> <p><b>Applied standards:</b></p> <table style="width: 100%; border: none;"> <tr> <td style="width: 33%;">EN 61800-5-1:2007+A1:2017</td> <td style="width: 33%;">EN 61800-3:2004+A1:2012+AC:2014</td> <td style="width: 33%;">EN 61800-9-1:2017</td> </tr> <tr> <td>EN 60529:1991+A1:2000+A2:2013+AC:2016</td> <td>EN 50581:2012</td> <td>EN 61800-9-2:2017</td> </tr> </table> <p>It is necessary to notice the data in the operating manual to meet the regulations of the EMC-Directive.                  Specially take care about correct EMC installation and cabling, differences in the field of applications and if necessary original accessories.</p> <p>First marking was carried out in 2009.</p> <p><b>Bargtheide, 28.05.2019</b></p> <div style="display: flex; justify-content: space-around; margin-top: 20px;"> <div style="text-align: center;">  <p>U. Küchenmeister Managing Director</p> </div> <div style="text-align: center;">  <p>pp F. Wiedemann Head of Inverter Division</p> </div> </div>		<b>Low Voltage Directive</b>	<b>2014/35/EU</b>	OJ. L 96 of 29.3.2014, p. 357–374	<b>EMC Directive</b>	<b>2014/30/EU</b>	OJ. L 96 of 29.3.2014, p. 79–106	<b>RoHS Directive</b>	<b>2011/65/EU</b>	OJ. L 174 of 1.7.2011, p. 88–11	<b>Delegated Directive(EU)</b>	<b>2015/863</b>	OJ. L 137 of 4.6.2015, p. 10–12	EN 61800-5-1:2007+A1:2017	EN 61800-3:2004+A1:2012+AC:2014	EN 61800-9-1:2017	EN 60529:1991+A1:2000+A2:2013+AC:2016	EN 50581:2012	EN 61800-9-2:2017
<b>Low Voltage Directive</b>	<b>2014/35/EU</b>	OJ. L 96 of 29.3.2014, p. 357–374																	
<b>EMC Directive</b>	<b>2014/30/EU</b>	OJ. L 96 of 29.3.2014, p. 79–106																	
<b>RoHS Directive</b>	<b>2011/65/EU</b>	OJ. L 174 of 1.7.2011, p. 88–11																	
<b>Delegated Directive(EU)</b>	<b>2015/863</b>	OJ. L 137 of 4.6.2015, p. 10–12																	
EN 61800-5-1:2007+A1:2017	EN 61800-3:2004+A1:2012+AC:2014	EN 61800-9-1:2017																	
EN 60529:1991+A1:2000+A2:2013+AC:2016	EN 50581:2012	EN 61800-9-2:2017																	

### 8.4 Reduced output power

The variable frequency drives are designed for specific overload situations. For example, 1.5x overcurrent can be used for 60 s. For approx. 3.5 s a 2x overcurrent is possible. Reduction of the overload capacity or its time must be taken into account in the following circumstances:

- Output frequencies < 4.5 Hz and constant voltages (needle stationary)
- Pulse frequencies greater than the nominal pulse frequency (P504)
- Increased line voltages > 400 V
- Increased heat sink temperature

On the basis of the following characteristic curves, the particular current/power limitation can be read off.

#### 8.4.1 Increased heat dissipation due to pulse frequency

This illustration shows how the output current must be reduced, depending on the pulse frequency for 230 V and 400 V devices, in order to avoid excessive heat dissipation in the variable frequency drive.

For 400 V devices, the reduction begins at a pulse frequency above 6 kHz. For 230 V devices, the reduction begins at a pulse frequency above 8 kHz.

The diagram shows the possible current load capacity for continuous operation.

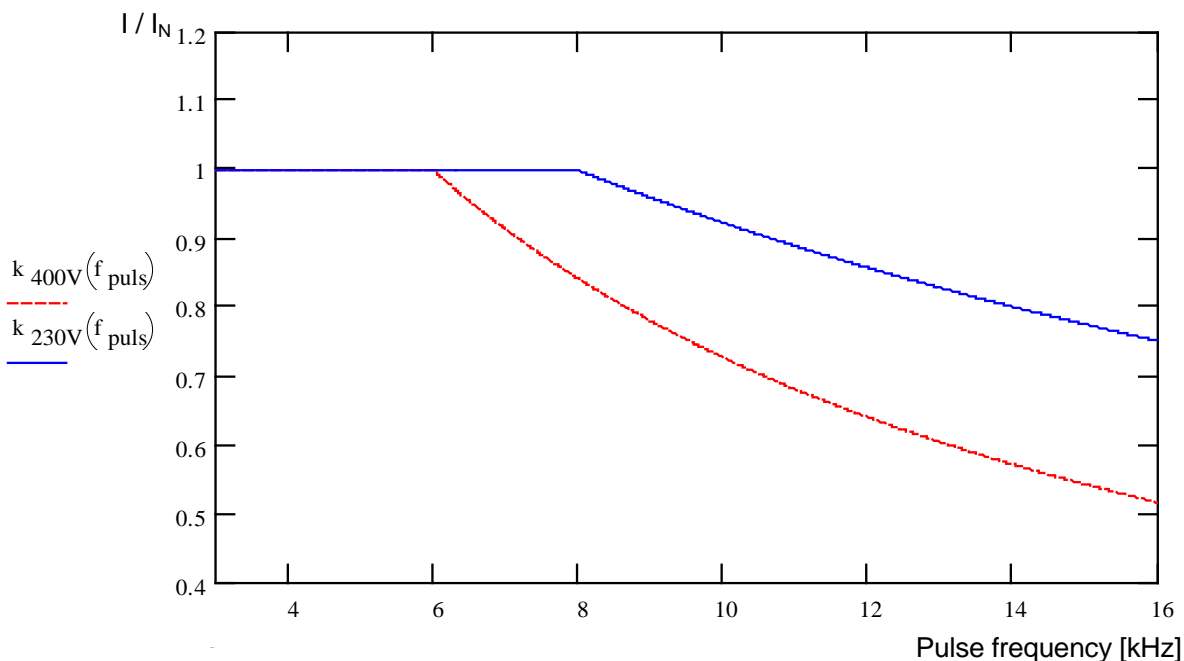

Figure 34: Heat losses due to pulse frequency

### 8.4.2 Reduced overcurrent due to time

The possible overload capacity changes depending on the duration of an overload. Several values are cited in this table. If one of these limiting values is reached, the variable frequency drive must have sufficient time (with low utilization or without load) in order to regenerate itself.

If operated repeatedly in the overload region at short intervals, the limiting values stated in the tables are reduced.

<b>230 V devices:</b> Reduced overload capacity (approx.) due to pulse frequency (P504) and time						
Pulse frequency [kHz]	Time [s]					
	> 600	60	30	20	10	3.5
3...8	110%	150%	170%	180%	180%	200%
10	103%	140%	155%	165%	165%	180%
12	96%	130%	145%	155%	155%	160%
14	90%	120%	135%	145%	145%	150%
16	82%	110%	125%	135%	135%	140%

<b>400 V devices:</b> Reduced overload capacity (approx.) due to pulse frequency (P504) and time						
Pulse frequency [kHz]	Time [s]					
	> 600	60	30	20	10	3.5
3...6	110%	150%	170%	180%	180%	200%
8	100%	135%	150%	160%	160%	165%
10	90%	120%	135%	145%	145%	150%
12	78%	105%	120%	125%	125%	130%
14	67%	92%	104%	110%	110%	115%
16	57%	77%	87%	92%	92%	100%

Table 17: Overcurrent relative to time



### 8.4.3 Reduced overcurrent due to output frequency

To protect the power unit at low output frequencies (<4.5 Hz), a monitoring system is provided with which the temperature of the IGBTs (*insulated-gate bipolar transistor*) due to high current is determined. In order to prevent current being taken off above the limit shown in the diagram, a pulse switch-off (P537) with a variable limit is introduced. At a standstill, with 6 kHz pulse frequency, current above 1.1x the nominal current cannot be taken off.

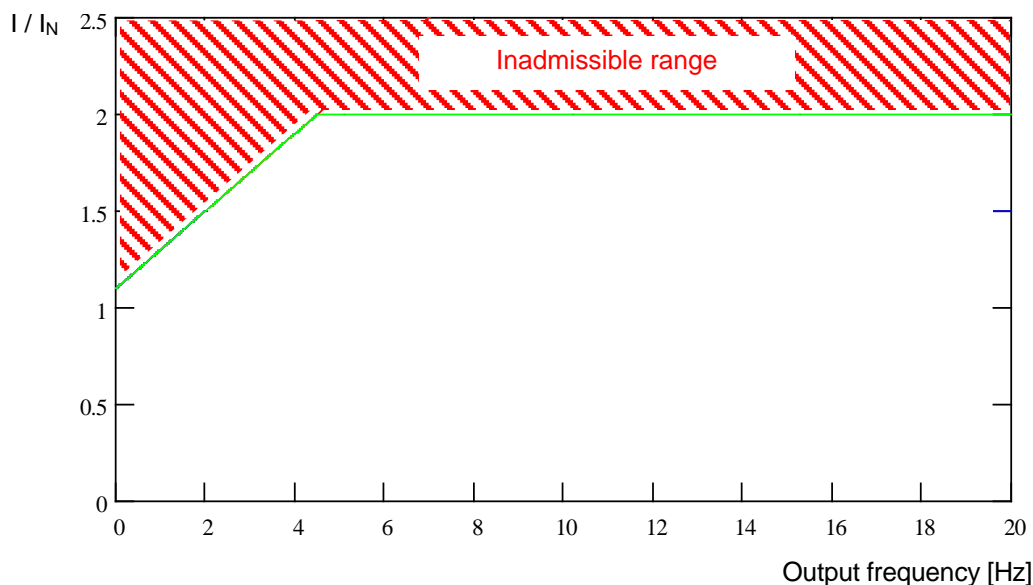

The upper limiting values for the various pulse frequencies can be obtained from the following tables. The value (10 ... 201) which can be set in parameter P537, is limited to the value stated in the tables according to the pulse frequency. Values below the limit can be set as required.

230 V devices: Reduced overload capacity (approx.) due to pulse frequency (P504) and output frequency							
Pulse frequency [kHz]	Output frequency [Hz]						
	4.5	3.0	2.0	1.5	1.0	0.5	0
3 ... 8	200%	170%	150%	140%	130%	120%	110%
10	180%	153%	135%	126%	117%	108%	100%
12	160%	136%	120%	112%	104%	96%	95%
14	150%	127%	112%	105%	97%	90%	90%
16	140%	119%	105%	98%	91%	84%	85%

400 V devices: Reduced overload capacity (approx.) due to pulse frequency (P504) and output frequency							
Pulse frequency [kHz]	Output frequency [Hz]						
	4.5	3.0	2.0	1.5	1.0	0.5	0
3 ... 6	200%	170%	150%	140%	130%	120%	110%
8	165%	140%	123%	115%	107%	99%	90%
10	150%	127%	112%	105%	97%	90%	82%
12	130%	110%	97%	91%	84%	78%	71%
14	115%	97%	86%	80%	74%	69%	63%
16	100%	85%	75%	70%	65%	60%	55%

Table 18: Overcurrent relative to pulse and output frequency

### 8.4.4 Reduced output current due to line voltage

The devices are designed with thermal characteristics according to the nominal output currents. Accordingly, for lower line voltages, higher currents cannot be taken off in order to maintain the stated power constant. For line voltages above 400 V, there is a reduction of the permissible continuous output current, which is inversely proportional to the line voltage, in order to compensate for the increased switching losses.

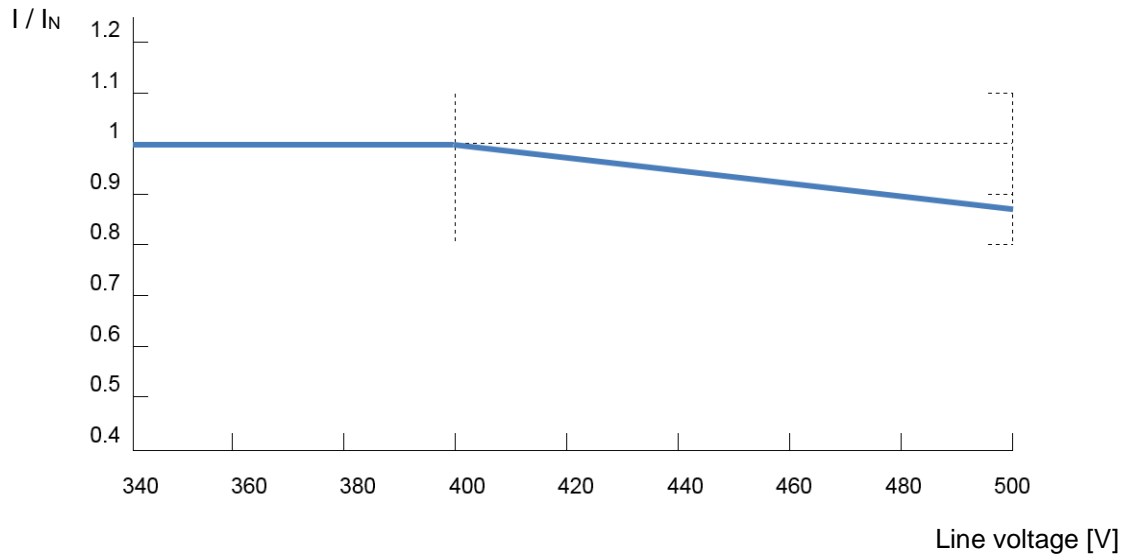

Figure 35: Output current due to line voltage

### 8.4.5 Reduced output current due to the heat sink temperature

The temperature of the heat sink is included in the calculation of the reduction of output current, so that at low heat sink temperatures, a higher load capacity can be permitted, especially for higher pulse frequencies. At high heat sink temperatures, the reduction is increased correspondingly. The ambient temperature and the ventilation conditions for the device can therefore be optimally exploited.

### 8.4.6 Reduced output current due to speed

Size 1 – 3 devices are designed such that the waste heat that occurs can only be given off via the housing in sufficient quantities if the **variable frequency drive** with motor installation is also cooled by an air flow. If this air flow is generated by a self-ventilated motor (impeller mounted on the motor shaft), the strength of the air flow then depends on the motor speed. This means that as the motor speed reduces, so does the air flow. Depending on the variable frequency drive and the speed that is present, appropriate restrictions in the possible output power (S1 operation) must be taken into consideration.

This restriction can be determined on the basis of the following graph. However, it must be taken into consideration that the result that is determined can only be a rough estimate, since various influential factors such as specific variable frequency drive/motor combinations cannot also be taken into consideration. Please refer to catalog [G4014](#) for more information.

The "k" factor of the following graph must be multiplied by the nominal data of the variable frequency drive concerned, and therefore results in the possible continuous current or the possible continuous output in S1 operation.

**Example:**

SK 200E-401-340 A,  $I_{rated} = 8.9 \text{ A}$ ,  $f_{out}: 20 \text{ Hz} \rightarrow k=0.7$

$I = I_{rated} \times k \rightarrow I = 8.9 \text{ A} \times 0.7 = 6.2 \text{ A}$  in S1 operation

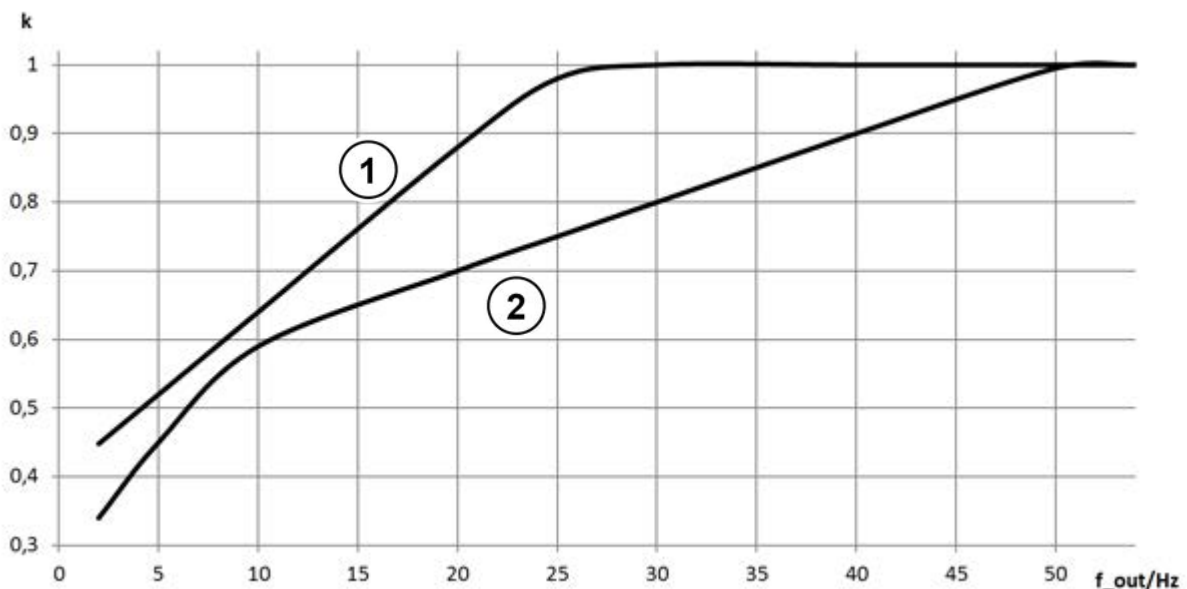

- 1 = All device sizes 1 to 3 except the devices from ( 2 )
- 2 = SK 2xxE-111-323-A, SK 2xxE-221-323-A, SK 2xxE-401-323-A,  
SK 2xxE-221-340-A, SK 2xxE-401-340-A, SK 2xxE-751-340-A

Figure 36: Derating factor "k" for motor installation (self-ventilated)

## 8.5 Operation on the VFD circuit breaker

With SK 2xxE variable frequency drives (except 115 V devices), leakage currents of > 40 mA are to be expected if the line filter is active. In other words, an VFD personal protection circuit breaker must be avoided if possible.

If the variable frequency drive is going to be operated with an VFD personal protection circuit breaker, the leakage currents against PE could be reduced to 10 - 20 mA jumpers. However, the VFD loses its specified interference suppression level because of "operation on IT network".

Only all-current sensitive VFD circuit breakers (type B or B+) must be used.

(please see chapter 2.4.2.1 "Power supply connection (L1, L2(/N), L3, PE)")

( See also document [TI 800\\_000000003](#))

### 8.6 System bus

The device and many of the associated components communicate with each other via the system bus. This bus system is a CAN bus with CANopen protocol. Up to four variable frequency drives and their components (field bus module, absolute encoder, I/O modules etc.) can be connected to the system bus. Integration of the components into the system bus does not require any specific knowledge of the bus on the part of the user.

Only the proper physical configuration of the bus system and if necessary the correct addressing of the participants need to be taken into account by the user.

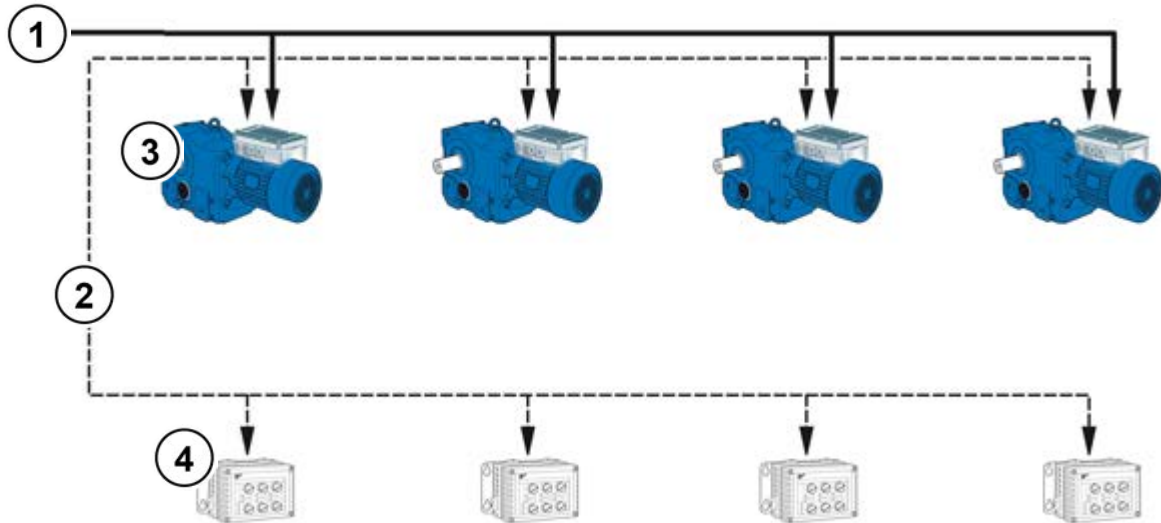

No.	Model
1	Power supply connection
2	System bus cable (CAN_H, CAN-L, GND)
3	Variable Frequency Drives
4	Options <ul style="list-style-type: none"> <li>• Bus modules</li> <li>• IO extensions</li> <li>• CANopen rotary encoder</li> </ul>

Terminal	Meaning
77	System bus+ (CAN H)
78	System bus- (CAN L)
40	GND (reference potential)
Terminal numbers may differ (depending on the device)	

#### Information

#### Communication interference

To minimize the risk of communication interference, the **GND –potentials** (Terminal 40) of all GNDs which are linked via the system bus GND **must be connected together**. The shield of the bus cable must also be connected to PE at both ends.

#### Information

#### Communication on the system bus

Communication on the system bus does not take place until an expansion module is connected to it or if the master in a master/slave system is parameterized to **P503=3** and the slave to **P503=2**. This is particularly important if several variable frequency drives connected to the system bus in parallel are to be read out using the NORDCON parameterization software.

**Physical structure**

<b>Standard</b>	CAN
<b>Physical design</b>	2x2, twisted pair, shielded, stranded wires, wire cross-section $\geq 0.25 \text{ mm}^2$ (AWG23), surge impedance approx. $120 \Omega$
<b>Bus length</b>	max. 20 m total network max. 20 m between 2 subscribers
<b>Structure</b>	preferably linear
<b>Spur cables</b>	possible, (max. 6 m)
<b>Termination resistors</b>	$120 \Omega$ , 250 mW at both ends of a system bus (with VFD or SK xU4-... via DIP switches)
<b>Baud rate</b>	250 kBaud - pre-set

The CAN\_H and CAN\_L signals must be connected using a twisted pair of wires. The GND potentials are connected using the second pair of wires.



**Addressing**

If several variable frequency drives are connected to a system bus, these devices must be assigned with unique addresses. This happens preferably through the DIP switch S1 on the device (please see chapter 4.3.2.2 "DIP switches (S1)").

For field bus modules, no assignment of addresses is necessary. The module identifies all the variable frequency drives automatically. Access to the individual inverters takes place via the field bus master (PLC) Details of how this is carried out are explained in the relevant bus instructions or data sheets for the individual modules.

I/O extensions must be assigned to the relevant variable frequency drive. This is carried out by means of a DIP switch on the I/O module. A special case for the I/O extensions is the "Broadcast" mode. In this mode, the data from the I/O extension (analogue values, inputs etc.) are sent to all inverters simultaneously. Via the parameterization in each individual variable frequency drive, a decision is made as to which of the received values are to be used. More information about the settings can be found in the [data sheets](#) for the relevant modules.

** Information**

**Addressing**

Care must be taken that each address is only assigned once. In a CAN-based network double assignment of addresses may lead to misinterpretation of the data and therefore undefined activities in the system.

**Integration of devices from other manufacturers**

In principle, the integration of other devices into this bus system is possible. These must support the CANopen protocol and a 250 kBaud baud rate. The address range (Node ID) 1 to 4 is reserved for additional CANopen masters. All other participants must be assigned addresses between 50 and 79.

### Example of variable frequency drive addressing

Variable Frequency Drives	Addressing via DIP switch S1		Resulting node ID	Node ID AG
	DIP 2	DIP 1	Variable Frequency Drives	
VFD1	OFF	OFF	32	33
VFD2	OFF	ON	34	35
VFD3	ON	OFF	36	37
VFD4	ON	ON	38	39

### Information

### CANopen absolute encoders

In applications with CANopen absolute encoders, the encoders must be assigned to the relevant VFD via the node ID. If there is one encoder and four variable frequency drives in the system bus, for example, and the encoder is to work together with VFD3, the encoder must be set to a node ID of 37, see table above **Node ID AG**

## 8.7 Energy efficiency

### **WARNING**

#### Unexpected movement due to overload

In case of overload of the drive there is a risk that the motor will "break down" (sudden loss of torque). An overload may be caused e.g. by underdimensioning of the drive unit or by the occurrence of sudden peak loads. Sudden peak loads may be of a mechanical origin (e.g. blockage) or may be caused by extremely steep acceleration ramps (P102, P103, P426).

Depending on the type of application, "breakdown" of the motor may cause unexpected movement (e.g. dropping of loads by lifting gear).

To prevent any risk, the following must be observed:

- For lifting gear applications or applications with frequent large load changes, parameter P219 must remain in the factory setting (100%).
- Do not underdimension the drive unit, provide adequate overload reserves.
- If necessary, provide fall protection (e.g. for lifting gear) or equivalent protective measures.

NORD variable frequency drives have low power consumption and are therefore highly efficient. In addition, with the aid of automatic magnetization optimization (parameter (P219)) the inverter provides a possibility for increasing the overall efficiency of the drive in certain applications (in particular applications with partial load).

Depending on the required torque, the magnetizing current (or the motor torque) is decreased by the variable frequency drive insofar as necessary for the instantaneous power requirement. The resulting considerable reduction in power consumption as well as the optimization of the  $\cos \varphi$  factor to the motor setpoint even in the partial load range contributes to creating optimum conditions both with regard to energy consumption and line power characteristics.

A parameterization which is different from the factory setting (Factory setting = 100 %) is only permissible for applications which do not require rapid torque changes. (For details, see parameter (P219))

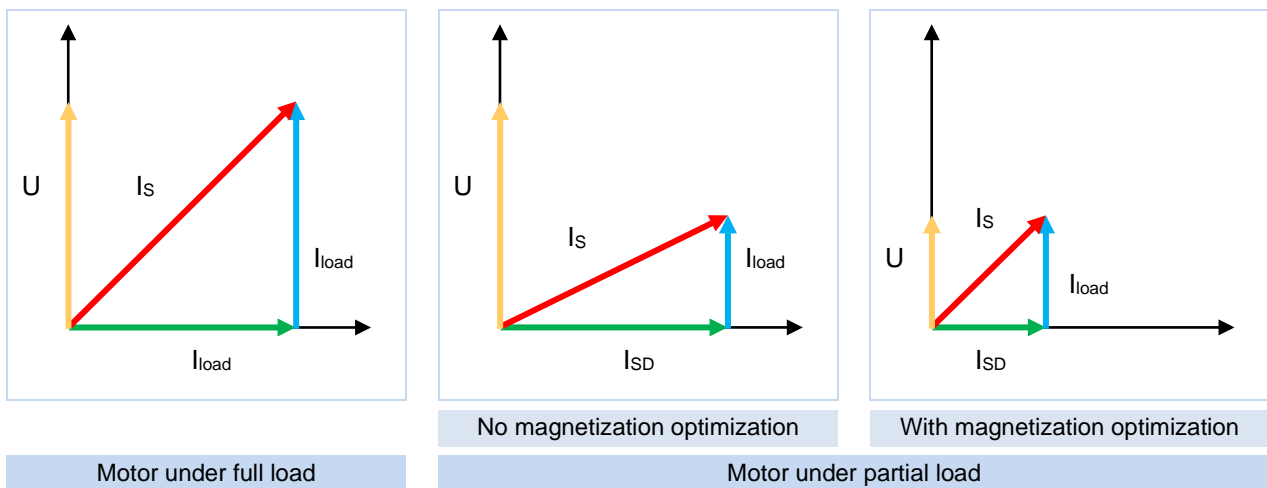

- $I_s$  = Motor current vector (line current)
- $I_{SD}$  = Magnetization current vector (magnetization current)
- $I_{load}$  = Load current vector (load current)

Figure 37: Energy efficiency due to automatic magnetization optimization



### 8.8 Motor data - characteristic curves

The possible characteristic curves with which the motors can be operated are explained in the following. The nameplate data of the motor is relevant for operation with the 50 Hz or 87 Hz characteristic curve (see Section 4.1 "Factory settings"). The use of specially calculated motor data is required for operation with a 100 Hz characteristic curve (see Section 8.8.3 "100 Hz characteristic curve (only 400 V devices)").

#### 8.8.1 50 Hz characteristic curve

(→ Variation 1:10)

The motor used for 50 Hz operation can be operated up to its rated point at 50 Hz with nominal torque. Operation above 50 Hz is possible, however the output torque reduces in a non-linear manner (see following diagram). Above the rated point, the motor enters its field weakening range, since the voltage cannot be increased beyond the value of the line voltage when the frequency is increased above 50 Hz.

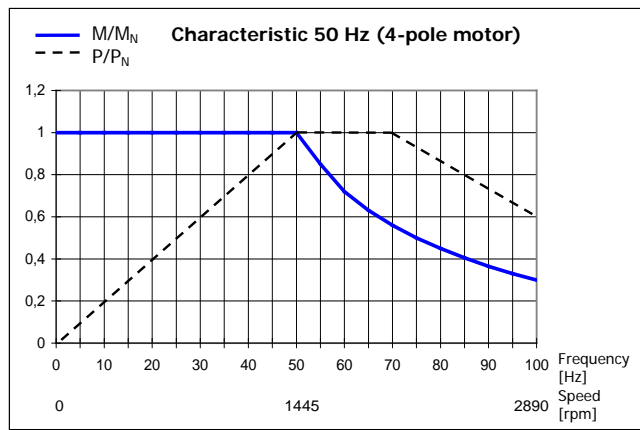

Figure 38: 50 Hz characteristic curve

### 115 V/230 V variable frequency drive

With 115 V devices, the input voltage is doubled inside the device so that the required maximum output voltage of 230 V is achieved by the device.

The following data refers to a 230/400 V motor winding. They apply for IE1 and IE2 motors. It should be noted that these details may deviate slightly, as motors are subject to certain manufacturing tolerances. It is recommended that the resistance of the connected motor is measured by the variable frequency drive (P208/P220).

Motor (IE1) SK ...	Variable Frequency Drive SK 2xxE-...	M <sub>N</sub> ** [Nm]	Parameterization data of variable frequency drive							
			F <sub>N</sub> [Hz]	n <sub>N</sub> [rpm]	I <sub>N</sub> [A]	U <sub>N</sub> [V]	P <sub>N</sub> [kW]	cos φ	Y/Δ	R <sub>St</sub> [Ω]
71S/4	250-x23-A*	1.73	50	1365	1.3	230	0.25	0.79	Δ	39.9
71L/4	370-x23-A*	2.56	50	1380	1.89	230	0.37	0.71	Δ	22.85
80S/4	550-x23-A*	3.82	50	1385	2.62	230	0.55	0.75	Δ	15.79
80L/4	750-x23-A*	5.21	50	1395	3.52	230	0.75	0.75	Δ	10.49
90S/4	111-x23-A	7.53	50	1410	4.78	230	1.1	0.76	Δ	6.41
90L/4	151-323-A	10.3	50	1390	6.11	230	1.5	0.78	Δ	3.99
100L/4	221-323-A	14.6	50	1415	8.65	230	2.2	0.78	Δ	2.78
100LA/4	301-323-A	20.2	50	1415	11.76	230	3.0	0.78	Δ	1.71
112M/4	401-323-A	26.4	50	1430	14.2	230	4.0	0.83	Δ	1.11
132S/4	551-323-A	36.5	50	1450	20.0	230	5.5	0.8	Δ	0.72
132M/4	751-323-A	49.6	50	1450	26.8	230	7.5	0.79	Δ	0.46
132 MA/4	112-323-A	60.6	50	1455	32.6	230	9.2	0.829	Δ	0.39

\* the same data applies to the use of the 115 V version of the SK2xxE

\*\* at rated point

Motor (IE2) SK ...	Variable Frequency Drive SK 2xxE-...	M <sub>N</sub> ** [Nm]	Parameterization data of variable frequency drive							
			F <sub>N</sub> [Hz]	n <sub>N</sub> [rpm]	I <sub>N</sub> [A]	U <sub>N</sub> [V]	P <sub>N</sub> [kW]	cos φ	Y/Δ	R <sub>St</sub> [Ω]
80SH/4	550-x23-A*	3.73	50	1415	2.39	230	0.55	0.7	Δ	9.34
80LH/4	750-x23-A*	5.06	50	1410	3.12	230	0.75	0.75	Δ	6.30
90SH/4	111-x23-A	7.32	50	1430	4.26	230	1.1	0.8	Δ	4.96
90LH/4	151-323-A	10.1	50	1420	5.85	230	1.5	0.79	Δ	3.27
100LH/4	221-323-A	14.5	50	1445	8.25	230	2.2	0.79	Δ	1.73
100AH/4	301-323-A	20.3	50	1420	11.1	230	3.0	0.77	Δ	1.48
112MH/4	401-323-A	26.6	50	1440	14.1	230	4.0	0.83	Δ	1.00
132SH/4	551-323-A	36.6	50	1455	18.8	230	5.5	0.83	Δ	0.60
132MH/4	751-323-A	49.1	50	1455	26.2	230	7.5	0.8	Δ	0.42
160MH/4	112-323-A	71.7	50	1465	35.5	230	11.0	0.85	Δ	0.26

\* the same data applies to the use of the 115 V version of the SK2xxE

\*\* at rated point

### b) 400 V variable frequency drive

The following data is based on an output of 2.2 kW using a 230/400 V motor winding. 400/690 V windings are used for 3 kW and higher.

They apply to IE1 and IE2 motors. It should be noted that these details may deviate slightly as motors are subject to certain manufacturing tolerances. It is recommended that the resistance of the connected motor is measured by the variable frequency drive (P208/P220).

Motor (IE1) SK ...	Variable Frequency Drive SK 2xxE-...	M <sub>N</sub> * [Nm]	Parameterization data of variable frequency drive							
			F <sub>N</sub> [Hz]	n <sub>N</sub> [rpm]	I <sub>N</sub> [A]	U <sub>N</sub> [V]	P <sub>N</sub> [kW]	cos φ	Y/Δ	R <sub>St</sub> [Ω]
80S/4	550-340-A	3.82	50	1385	1.51	400	0.55	0.75	Y	15.79
80L/4	750-340-A	5.21	50	1395	2.03	400	0.75	0.75	Y	10.49
90S/4	111-340-A	7.53	50	1410	2.76	400	1.1	0.76	Y	6.41
90L/4	151-340-A	10.3	50	1390	3.53	400	1.5	0.78	Y	3.99
100L/4	221-340-A	14.6	50	1415	5.0	400	2.2	0.78	Y	2.78
100LA/4	301-340-A	20.2	50	1415	6.8	400	3.0	0.78	Δ	5.12
112M/4	401-340-A	26.4	50	1430	8.24	400	4.0	0.83	Δ	3.47
132S/4	551-340-A	36.5	50	1450	11.6	400	5.5	0.8	Δ	2.14
132M/4	751-340-A	49.6	50	1450	15.5	400	7.5	0.79	Δ	1.42
160M/4	112-340-A	72.2	50	1455	20.9	400	11.0	0.85	Δ	1.08
160L/4	152-340-A	98.1	50	1460	28.2	400	15.0	0.85	Δ	0.66
180MX/4	182-340-A	122	50	1460	35.4	400	18.5	0.83	Δ	0.46
180LX/4	222-340-A	145	50	1460	42.6	400	22.0	0.82	Δ	0.35

\* at rated point

Motor (IE2) SK ...	Variable Frequency Drive SK 2xxE-...	M <sub>N</sub> * [Nm]	Parameterization data of variable frequency drive							
			F <sub>N</sub> [Hz]	n <sub>N</sub> [rpm]	I <sub>N</sub> [A]	U <sub>N</sub> [V]	P <sub>N</sub> [kW]	cos φ	Y/Δ	R <sub>St</sub> [Ω]
80SH/4	550-340-A	3.82	50	1415	1.38	400	0.55	0.7	Y	9.34
80LH/4	750-340-A	5.21	50	1410	1.8	400	0.75	0.75	Y	6.30
90SH/4	111-340-A	7.53	50	1430	2.46	400	1.1	0.8	Y	4.96
90LH/4	151-340-A	10.3	50	1420	3.38	400	1.5	0.79	Y	3.27
100LH/4	221-340-A	14.6	50	1445	4.76	400	2.2	0.79	Y	1.73
100AH/4	301-340-A	20.2	50	1420	6.4	400	3.0	0.77	Δ	4.39
112MH/4	401-340-A	26.4	50	1440	8.12	400	4.0	0.83	Δ	2.96
132SH/4	551-340-A	36.5	50	1455	10.82	400	5.5	0.83	Δ	1.84
132MH/4	751-340-A	49.6	50	1455	15.08	400	7.5	0.8	Δ	1.29
160MH/4	112-340-A	72.2	50	1465	20.5	400	11.0	0.85	Δ	0.78
160LH/4	152-340-A	98.1	50	1465	27.5	400	15.0	0.87	Δ	0.53
180MH/4	182-340-A	122	50	1475	34.9	400	18.5	0.84	Δ	0.36
180LH/4	222-340-A	145	50	1475	40.8	400	22.0	0.86	Δ	0.31

\* at rated point

### 8.8.2 87 Hz characteristic curve (only 400 V devices)

(→ Variation 1:17 AM)

The 87 Hz characteristic represents an extension of the speed adjustment range with a constant rated motor torque. The following points must be met for realization:

- Motor delta connection with a motor winding for 230/400 V
- Variable Frequency Drive with an operating voltage 3~400 V
- Output current of variable frequency drive must be greater than the delta current of the motor used (ref. value → variable frequency drive power  $\geq \sqrt{3}$  motor power)

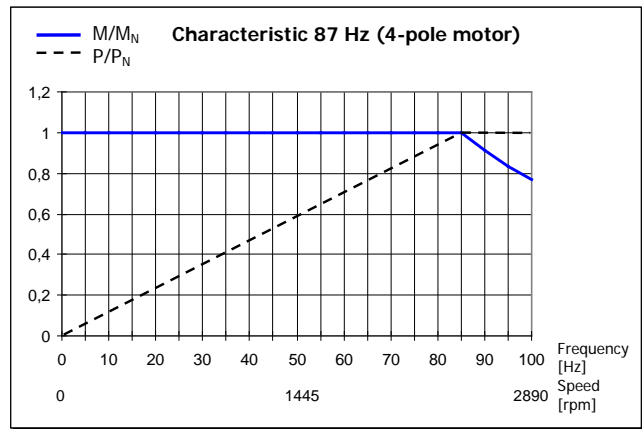

Figure 39: 87 Hz characteristic curve

In this configuration, the motor used has a rated operating point at 230 V/50 Hz and an extended operating point at 400 V/87 Hz. This increases the power of the drive by a factor of  $\sqrt{3}$ . The nominal torque of the motor remains constant up to a frequency of 87 Hz. Operation of a 230 V winding with 400 V is totally uncritical as the insulation is designed for test voltages of  $> 1000$  V.

**NOTE: The following motor data applies to standard motors with 230 V/400 V windings.**

Motor (IE1) SK ...	Variable Frequency Drive SK 2xxE-....	M <sub>N</sub> * [Nm]	Parameterization data of variable frequency drive							
			F <sub>N</sub> [Hz]	n <sub>N</sub> [rpm]	I <sub>N</sub> [A]	U <sub>N</sub> [V]	P <sub>N</sub> [kW]	cos φ	Y/Δ	R <sub>St</sub> [Ω]
71S/4	550-340-A	1.73	50	1365	1.3	230	0.25	0.79	Δ	39.9
71L/4	750-340-A	2.56	50	1380	1.89	230	0.37	0.71	Δ	22.85
80S/4	111-340-A	3.82	50	1385	2.62	230	0.55	0.75	Δ	15.79
80L/4	151-340-A	5.21	50	1395	3.52	230	0.75	0.75	Δ	10.49
90S/4	221-340-A	7.53	50	1410	4.78	230	1.1	0.76	Δ	6.41
90L/4	301-340-A	10.3	50	1390	6.11	230	1.5	0.78	Δ	3.99
100L/4	401-340-A	14.6	50	1415	8.65	230	2.2	0.78	Δ	2.78
100LA/4	551-340-A	20.2	50	1415	11.76	230	3.0	0.78	Δ	1.71
112M/4	751-340-A	26.4	50	1430	14.2	230	4.0	0.83	Δ	1.11
132S/4	112-340-A	36.5	50	1450	20.0	230	5.5	0.8	Δ	0.72
132M/4	152-340-A	49.6	50	1450	26.8	230	7.5	0.79	Δ	0.46
132MA/4	182-340-A	60.6	50	1455	32.6	230	9.2	0.829	Δ	0.39
160MA/4	222-340-A	72.2	50	1455	37	230	11	0.85	Δ	0.36

\* at rated point

Motor (IE2) SK ...	Variable Frequency Drive SK 2xxE-...	M <sub>N</sub> * [Nm]	Parameterization data of variable frequency drive							
			F <sub>N</sub> [Hz]	n <sub>N</sub> [rpm]	I <sub>N</sub> [A]	U <sub>N</sub> [V]	P <sub>N</sub> [kW]	cos φ	Y/Δ	R <sub>St</sub> [Ω]
80SH/4	111-340-A	3.73	50	1415	2.39	230	0.55	0.7	Δ	9.34
80LH/4	151-340-A	5.06	50	1410	3.12	230	0.75	0.75	Δ	6.30
90SH/4	221-340-A	7.32	50	1430	4.26	230	1.1	0.8	Δ	4.96
90LH/4	301-340-A	10.1	50	1420	5.85	230	1.5	0.79	Δ	3.27
100LH/4	401-340-A	14.5	50	1445	8.25	230	2.2	0.79	Δ	1.73
100AH/4	551-340-A	20.3	50	1420	11.1	230	3.0	0.77	Δ	1.48
112MH/4	751-340-A	26.6	50	1440	14.1	230	4.0	0.83	Δ	1.00
132SH/4	112-340-A	36.6	50	1455	18.8	230	5.5	0.83	Δ	0.60
132MH/4	152-340-A	49.1	50	1455	26.2	230	7.5	0.8	Δ	0.42
160MH/4	182-340-A	71.7	50	1465	35.5	230	11.0	0.85	Δ	0.26
160LH/4	222-340-A	97.8	50	1465	46.0	230	15.0	0.87	Δ	0.17

\* at rated point

### 8.8.3 100 Hz characteristic curve (only 400 V devices)

(→ Variation 1:20 AM)

An operating point 100 Hz/400 V can be selected for a greater speed adjustment range with up to a ratio of 1:20. Special motor data is required in this case (see below) that differs from the normal 50 Hz data. It must be ensured in this case that a constant torque is generated across the entire adjustment range but that it is smaller than the nominal torque for 50 Hz operation.

The advantage, in addition to the greater speed adjustment range, is the improved motor temperature behavior. An external fan is not absolutely essential for smaller output speed ranges.

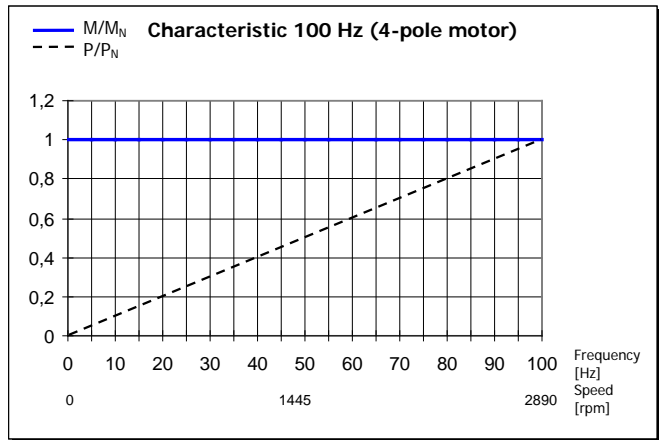

Figure 40: 100 Hz characteristic curve

**NOTE:** The following motor data applies for standard motors with a 230/400 V winding. It must be noted that this information may change slightly because the motors are subject to certain tolerances. It is recommended that the resistance of the connected motor is measured by the variable frequency drive (P208/P220).

Motor (IE1) SK ...	Variable Frequency Drive SK 2xxE-...	M <sub>N</sub> * [Nm]	Parameterization data of variable frequency drive							
			F <sub>N</sub> [Hz]	n <sub>N</sub> [rpm]	I <sub>N</sub> [A]	U <sub>N</sub> [V]	P <sub>N</sub> [kW]	cos φ	Y/Δ	R <sub>St</sub> [Ω]
71L/4	550-340-A	1.81	100	2900	1.59	400	0.55	0.72	Δ	22.85
80S/4	750-340-A	2.46	100	2910	2.0	400	0.75	0.72	Δ	15.79
80L/4	111-340-A	3.61	100	2910	2.8	400	1.1	0.74	Δ	10.49
90S/4	151-340-A	4.90	100	2925	3.75	400	1.5	0.76	Δ	6.41
90L/4	221-340-A	7.19	100	2920	4.96	400	2.2	0.82	Δ	3.99
100L/4	301-340-A	9.78	100	2930	6.95	400	3.0	0.78	Δ	2.78
100LA/4	401-340-A	12.95	100	2950	7.46	400	4.0	0.76	Δ	1.71
112M/4	551-340-A	17.83	100	2945	11.3	400	5.5	0.82	Δ	1.11
132S/4	751-340-A	24.24	100	2955	16.0	400	7.5	0.82	Δ	0.72
132MA/4	112-340-A	35.49	100	2960	23.0	400	11.0	0.80	Δ	0.39

\* at rated point

Motor (IE2) SK ...	Variable Frequency Drive SK 2xxE-...	M <sub>N</sub> * [Nm]	Parameterization data of variable frequency drive							
			F <sub>N</sub> [Hz]	n <sub>N</sub> [rpm]	I <sub>N</sub> [A]	U <sub>N</sub> [V]	P <sub>N</sub> [kW]	cos φ	Y/Δ	R <sub>St</sub> [Ω]
80SH/4	750-340-A	2.44	100	2930	1.9	400	0.75	0.7	Δ	9.34
80LH/4	111-340-A	3.60	100	2920	2.56	400	1.1	0.73	Δ	6.3
90SH/4	151-340-A	4.89	100	2930	3.53	400	1.5	0.79	Δ	4.96
90LH/4	221-340-A	7.18	100	2925	4.98	400	2.2	0.79	Δ	3.27
100LH/4	301-340-A	9.69	100	2955	6.47	400	3.0	0.78	Δ	1.73
100AH/4	401-340-A	13.0	100	2940	8.24	400	4.0	0.79	Δ	1.48
112MH/4	551-340-A	17.8	100	2950	11.13	400	5.5	0.82	Δ	1.0
132SH/4	751-340-A	24.2	100	2960	15.3	400	7.5	0.83	Δ	0.6
132MH/4	112-340-A	29.6	100	2965	19.5	400	9.2	0.79	Δ	0.42
160MH/4	152-340-A	48.3	100	2967	29.0	400	15.0	0.87	Δ	0.256
160LH/4	182-340-A	59.4	100	2975	35.7	400	18.5	0.86	Δ	0.168
180MH/4	222-340-A	70.5	100	2980	43.2	400	22	0.85	Δ	0.115

\* at rated point

Motor (IE3) SK ...	Variable Frequency Drive SK 2xxE-...	M <sub>N</sub> * [Nm]	Parameterization data of variable frequency drive							
			F <sub>N</sub> [Hz]	n <sub>N</sub> [rpm]	I <sub>N</sub> [A]	U <sub>N</sub> [V]	P <sub>N</sub> [kW]	cos φ	Y/Δ	R <sub>St</sub> [Ω]
80SP/4	750-340-A	2.44	100	2935	1.77	400	0.75	0.73	Δ	10.4
80LP/4	111-340-A	3.58	100	2930	2.13	400	1.1	0.84	Δ	6.5
90SP/4	151-340-A	4.86	100	2945	3.1	400	1.5	0.79	Δ	4.16
90LP/4	221-340-A	7.17	100	2930	4.33	400	2.2	0.83	Δ	3.15
100LP/4	301-340-A	9.65	100	2970	5.6	400	3.0	0.85	Δ	1.95
100AP/4	401-340-A	12.9	100	2970	7.42	400	4.0	0.85	Δ	1.58
112MP/4	551-340-A	17.8	100	2950	10.3	400	5.5	0.85	Δ	0.91
132SP/4	751-340-A	24.1	100	2970	14.3	400	7.5	0.83	Δ	0.503
132MP/4	112-340-A	29.6	100	2970	18.0	400	9.2	0.82	Δ	0.381
160SP/4	112-340-A	35.3	100	2975	21.0	400	11.0	0.85	Δ	0.295
160MP/4	152-340-A	48.2	100	2970	27.5	400	15.0	0.86	Δ	0.262
160LP/4	182-340-A	59.4	100	2975	34.4	400	18.5	0.85	Δ	0.169
180MP/4	222-340-A	70.4	100	2985	40.6	400	22.0	0.85	Δ	0.101

\* at rated point

## 8.9 Standardization of setpoint/target values

The following table contains details for the standardization of typical setpoint and actual values. These details relate to parameters (P400), (P418), (P543), (P546), (P740) or (P741).

Designation	Analog signal		Bus signal					
	Value range	Standardization	Value range	Max. value	100% =	-100% =	Standardization	Limitation absolute
Setpoint frequency {01}	0-10 V (10 V=100%)	P104 ... P105 (min - max) P104+(P105-P104) *U <sub>AIn</sub> (V)/10V	±100%	16384	4000 <sub>hex</sub> 16384 <sub>dec</sub>	C000 <sub>hex</sub> 16384 <sub>dec</sub>	4000 <sub>hex</sub> * f <sub>targ</sub> [Hz]/P105	P105
Frequency addition {02}	0-10 V (10 V=100%)	P410 ... P411 (min - max) P410+(P411-P410) *U <sub>AIn</sub> [V]/10V	±200%	32767	4000 <sub>hex</sub> 16384 <sub>dec</sub>	C000 <sub>hex</sub> 16384 <sub>dec</sub>	4000 <sub>hex</sub> * f <sub>targ</sub> [Hz]/P411	P105
Frequency subtraction {03}	0-10 V (10 V=100%)	P410 ... P411 (min - max) P410+(P411-P410) *U <sub>AIn</sub> [V]/10V	±200%	32767	4000 <sub>hex</sub> 16384 <sub>dec</sub>	C000 <sub>hex</sub> 16384 <sub>dec</sub>	4000 <sub>hex</sub> * f <sub>setp</sub> [Hz]/P411	P105
Minimum frequency {04}	0-10 V (10 V=100%)	50 Hz* U <sub>AIn</sub> (V)/10 V	0...200% (50Hz=100%)	32767	4000 <sub>hex</sub> 16384 <sub>dec</sub>	/	4000 <sub>hex</sub> * f <sub>min</sub> [Hz] / 50Hz	P105
Maximum frequency {05}	0-10 V (10 V=100%)	100Hz* U <sub>AIn</sub> (V)/10 V	0...200% (100Hz=100%)	32767	4000 <sub>hex</sub> 16384 <sub>dec</sub>	/	4000 <sub>hex</sub> * f <sub>max</sub> [Hz] / 100Hz	P105
Actual value Process controller {06}	0-10 V (10 V=100%)	P105* U <sub>AIn</sub> (V)/10 V	±200%	32767	4000 <sub>hex</sub> 16384 <sub>dec</sub>	C000 <sub>hex</sub> 16384 <sub>dec</sub>	4000 <sub>hex</sub> * f <sub>setp</sub> [Hz]/P105	P105
Setpoint process controller {07}	0-10 V (10 V=100%)	P105* U <sub>AIn</sub> (V)/10 V	±200%	32767	4000 <sub>hex</sub> 16384 <sub>dec</sub>	C000 <sub>hex</sub> 16384 <sub>dec</sub>	4000 <sub>hex</sub> * f <sub>targ</sub> [Hz]/P105	P105
Torque current limit {11}, {12}	0-10 V (10 V=100%)	P112* U <sub>AIn</sub> (V)/10 V	0...100%	16384	4000 <sub>hex</sub> 16384 <sub>dec</sub>	/	4000 <sub>hex</sub> * torque [%]/P112	P112
Current limit {13}, {14}	0-10 V (10 V=100%)	P536* U <sub>AIn</sub> (V)/10 V	0...100%	16384	4000 <sub>hex</sub> 16384 <sub>dec</sub>	/	4000 <sub>hex</sub> * Current limit [%] / (P536 * 100)	P536
Ramp time {15}	0-10 V (10 V=100%)	10 s* U <sub>AIn</sub> (V)/10 V	0...200%	32767	4000 <sub>hex</sub> 16384 <sub>dec</sub>	/	4000 <sub>hex</sub> * Bus setpoint/ 10s	20 s
<b>Actual values</b> {function}								
Actual frequency {01}	0-10 V (10 V=100%)	P201* U <sub>AOut</sub> (V)/10 V	±100%	16384	4000 <sub>hex</sub> 16384 <sub>dec</sub>	C000 <sub>hex</sub> 16384 <sub>dec</sub>	4000 <sub>hex</sub> * f[Hz]/P105	
Speed {02}	0-10 V (10 V=100%)	P202* U <sub>AOut</sub> (V)/10 V	±200%	32767	4000 <sub>hex</sub> 16384 <sub>dec</sub>	C000 <sub>hex</sub> 16384 <sub>dec</sub>	4000 <sub>hex</sub> * n[rpm]/P202	
Current {03}	0-10 V (10 V=100%)	P203* U <sub>AOut</sub> (V)/10 V	±200%	32767	4000 <sub>hex</sub> 16384 <sub>dec</sub>	C000 <sub>hex</sub> 16384 <sub>dec</sub>	4000 <sub>hex</sub> * I[A]/P203	
Torque current {04}	0-10 V (10 V=100%)	P112* 100/ √((P203) <sup>2</sup> - (P209) <sup>2</sup> )* U <sub>AOut</sub> (V)/10 V	±200%	32767	4000 <sub>hex</sub> 16384 <sub>dec</sub>	C000 <sub>hex</sub> 16384 <sub>dec</sub>	4000 <sub>hex</sub> * I <sub>q</sub> [A]/(P112)*100/ √((P203) <sup>2</sup> - (P209) <sup>2</sup> )	
Master value Setpoint frequency {19} ... {24}	/	/	±100%	16384	4000 <sub>hex</sub> 16384 <sub>dec</sub>	C000 <sub>hex</sub> 16384 <sub>dec</sub>	4000 <sub>hex</sub> * f[Hz]/P105	
Speed fro rotary encoder {22}	/	/	±200%	32767	4000 <sub>hex</sub> 16384 <sub>dec</sub>	C000 <sub>hex</sub> 16384 <sub>dec</sub>	4000 <sub>hex</sub> * n[rpm]/ P201*(60/Numb er of pairs of poles)	



### 8.10 Definition of setpoint and actual value processing (frequencies)

The frequencies used in parameters (P502) and (P543) are processed in various ways according the following table.

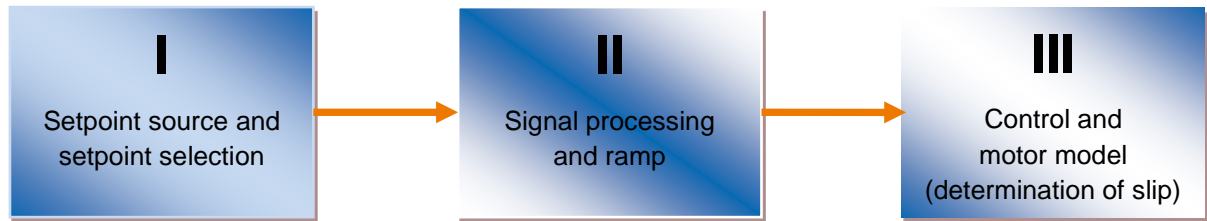

Func tion	Name	Meaning	Output to ...			without right/left	with slip
			I	II	III		
8	Setpoint frequency	Setpoint frequency from setpoint source	X				
1	Actual frequency	Setpoint frequency for motor model		X			
23	Actual frequency with slip	Actual frequency at motor			X		X
19	Setpoint frequency master value	Setpoint frequency from setpoint source Master value (free from enable correction)	X			X	
20	Setpoint frequency n R master value	Setpoint frequency from motor model Master value (free from enable correction)		X		X	
24	Master value of actual frequency with slip	Actual frequency from motor model Master value (free from enable correction)			X	X	X
21	Actual frequency without slip master value	Actual frequency without slip Master value			X		

Table 19: Processing of setpoints and actual values in the variable frequency drive

## 9 Maintenance and servicing information

### 9.1 Maintenance Instructions

When used as intended, variable frequency drives are *maintenance-free* (please see chapter 7 "Technical Data").

#### Dusty environments

If the device is being used in a dusty environment, the cooling surfaces should be regularly cleaned with compressed air.

#### Long-term storage

The device must be connected regularly to the supply network for at least 60 min.

If this is not done, there is a danger that the device may be destroyed.

If a device is to be stored for longer than one year, it must be recommissioned with the aid of a regulating transformer before normal connection to power supply.

#### *Long-term storage for 1 - 3 years*

- 30 min with 25% line voltage,
- 30 min with 50% line voltage,
- 30 min with 75% line voltage,
- 30 min with 100% line voltage

#### *Long-term storage for >3 years or if the storage period is not known:*

- 120 min with 25% line voltage,
- 120 min with 50% line voltage,
- 120 min with 75% line voltage,
- 120 min with 100% line voltage

The device must not be subject to load during the regeneration process.

After the regeneration process, the regulations described above apply again (at least 60 min on the grid 1x per year).

---

#### **i** Information

#### Control voltage with SK 2x5E

With devices of type SK 2x5E, a 24 V control voltage supply must be provided in order to make the regeneration process possible.

---

#### **i** Information

#### Accessories

The regulations for **long-term storage** apply to the accessories such as 24 V power supply modules (SK xU4-24V-..., SK TU4-POT-...) and the electronic brake inverter (SK CU4-MBR).

---

### 9.2 Service notes

Out technical support is available to reply to technical queries.

If you contact our technical support, please have the precise device model (nameplate/display), accessories and/or options, the software version used (P707) and the series number (name plate) at hand.

The device must be sent to the following address if it needs repairing:

**NORD Electronic DRIVESYSTEMS GmbH**  
 Tjüchkampstrasse 37  
 D-26605 Aurich

Please remove all non-original parts from the device.

No guarantee is given for any attached parts such as power cables, switches or external displays.

Please back up the parameter settings before sending in the device.

---

#### Information

Please note the reason for sending in the component/device and specify a contact for any queries that we might have.

You can obtain a return note from our web site ([Link](#)) or from our technical support.

Unless otherwise agreed, the device is reset to the factory settings after inspection or repair.

---

#### Information

In order to rule out the possibility that the cause of a device fault is due to an optional module, the connected optional modules should also be returned in case of a fault.

#### Contacts (telephone)

<b>Technical support</b>	During normal business hours	+49 (0) 4532-289-2125
	During normal business hours	+49 (0) 180-500-6184
<b>Repair inquiries</b>	During normal business hours	+49 (0) 4532-289-2115

The manual and additional information can be found on the Internet under [www.nord.com](http://www.nord.com).

### 9.3 Abbreviations

<b>AIN</b>	Analog input	<b>VFD (switch)</b>	Leakage current circuit breaker
<b>AS-i (AS1)</b>	AS Interface	<b>VFD</b>	Variable Frequency Drives
<b>ASi (LED)</b>	Status LED - AS interface	<b>I/O</b>	In/Out (Input/Output)
<b>ASM</b>	Asynchronous machine, asynchronous motor	<b>ISD</b>	Field current (current vector control)
<b>AOUT</b>	Analog output	<b>LED</b>	Light-emitting diode
<b>AUX</b>	Auxiliary (voltage)	<b>LPS</b>	List of projected slaves (AS-I)
<b>BW</b>	Braking resistor	<b>P1 ...</b>	Potentiometer 1 ...
<b>DI (DIN)</b>	Digital input	<b>PMSM</b>	Permanent magnet synchronous machine/-motor
<b>DigIn</b>		<b>PLC/SPS</b>	Programmable Logical Controller
<b>DS (LED)</b>	Status LED - device status	<b>PELV</b>	Safety low voltage
<b>CFC</b>	Current flux control (current-controlled, field-oriented control)	<b>S</b>	Supervisor parameter, P003
<b>DO (DOUT)</b>	Digital output	<b>S1...</b>	DIP switch 1 ...
<b>DigOut</b>		<b>SW</b>	Software version, P707
<b>I/O</b>	Input/Output	<b>TI</b>	Technical information/data sheet (data sheet for NORD accessories)
<b>EEPROM</b>	Non-volatile memory	<b>VFC</b>	Voltage flux control (current-controlled, field-oriented control)
<b>EMF</b>	Electromotive force (induction voltage)		
<b>EMC</b>	Electromagnetic compatibility		

## Key word index

"	
"Overtemperature" .....	225
"Overvoltage" .....	226
<b>3</b>	
3-Wire Ctrl.....	177
<b>A</b>	
Absolute min. freq. (P505).....	190
Acceleration time (P102) .....	141
Actual bus value 1 ... 3 (P543).....	202
Actual frequency processing .....	273
Actual values .....	272
Additional parameters.....	188
Address.....	275
Adjustment range	
1/10 .....	265, 268, 270
1/17 .....	269
Amplification ISD control (P213) .....	152
Analog input adjustment	
0% (P402) .....	170
100% (P403) .....	170
Analog input filter (P404) .....	171
Analog input voltage (P709) .....	211
Apparent power (P726) .....	213
Array parameters.....	138
AS Interface .....	120
ATEX .....	25, 28, 45, 76
ATEX	
ATEX zone 22, cat. 3D .....	77
ATEX	
Optional ATEX modules.....	78
ATEX	
EU conformity declaration.....	82
ATEX	
ATEX zone 22, cat. 3D .....	83
Automatic fault acknowledgment. (P506)....	190
Automatic magnetization adjustment (P219) .....	154
Automatic magnetization optimization.....	264
Automatic start (P428) .....	180
<b>B</b>	
Basic parameter .....	141
Boost derivative action (P215).....	152
Boost derivative action time (P216) .....	152
Brake chopper.....	53
Brake control.....	144, 147
Brake distance .....	145
Brake reaction time (P107) .....	144
Brake release time (P114) .....	147
Braking resistor .....	53, 238
Braking resistor (P556) .....	206
Braking resistor type (P557) .....	206
Bus	
setpoint (P546) .....	203
Bus I/O In Bits .....	185
Bus I/O Out Bits .....	185
Bus setpoints .....	203, 205
Bus status via PLC (P353).....	165
<b>C</b>	
CAN	
address (P515).....	193
CAN bus baud rate (P514) .....	192
CAN master cycle (P552) .....	204
CANopen status (P748).....	217
CE label .....	250
Charging error.....	233
Chopper P limit (P555).....	206
Configuration level (P744) .....	217
conformity declaration	
ATEX .....	82
Contact.....	275
Control connection .....	66
Control options.....	87, 90
Control parameter .....	157
Control terminals.....	68, 74, 123, 166
Control unit connection .....	66
Control word source (P509).....	191

COPY.....	112	Dynamic braking .....	53
Copy function.....	112	<b>E</b>	
Copy parameter set (P101) .....	141	EAC Ex .....	25, 28, 45, 76, 83
CSA .....	237	Certificate .....	84
cUL .....	237	EEPROM .....	86, 204
Current		EEPROM copy order (P550) .....	204
phase U (P732).....	214	Electrical data .....	237
phase V (P733).....	214	1~ 115 V.....	238
phase W (P734).....	214	1~ 230 V.....	239
Current limit (P536) .....	199	3~ 230 V.....	240
Current vector control.....	154	3~ 400 V.....	243
Curve setting .....	151, 152, 154	Electromechanical brake .....	65
Customer unit .....	90	EMC Directive .....	60, 250
<b>D</b>		Emerg. stop Error (P427).....	180
Database version (P742).....	216	Emitted interference.....	253
DC brake.....	145	EN 55011 .....	251
DC brake current (P109) .....	146	EN 61000 .....	253
DC brake time on (P110).....	146	EN 61800-3.....	251
DC link voltage (P736).....	215	Enable period (P715).....	212
DC run-on time (P559) .....	207	Encoder	
Deceleration time (P103).....	142	Connection .....	75
delay on/off switch (P475) .....	184	Encoder speed (P735).....	214
Derating .....	39	Energy efficiency.....	264
Device ID (P780) .....	219	Environmental standard.....	251
Diagnostic LEDs .....	223	Error messages.....	220, 221
Digital functions .....	175	EU conformity declaration	
Digital inputs (P420) .....	175	ATEX .....	82
Digital output		EU Declaration of Conformity .....	250
function (P434).....	181	<b>F</b>	
hysteresis (P436).....	183	Factor I <sup>2</sup> t motor (P533).....	198
set (P541).....	201	Factory setting (P523).....	195
standardization (P435).....	182	Factory settings.....	100, 265
Dimensions .....	43	FAQ	
DIP switch.....	107, 109	Troubleshooting.....	234
Direct current braking .....	145	Faults .....	220, 221
Disconnection mode (P108) .....	145	Features .....	13
Display .....	86	Ferrite core.....	40
Display factor (P002) .....	140	Field (P730) .....	214
Display selection (P001).....	139	Field current controller I (P316) .....	159
Distance calculator .....	145	Field current controller P (P315).....	159
Dynamic boost (P211).....	151	Field weakening controller I (P319) .....	160

Field weakening controller P (P318) .....	160	ISD control .....	154
Field weakening limit (P320) .....	160	<b>J</b>	
Filters		Jog frequency (P113).....	147
Analog output 1 (P418).....	174	<b>K</b>	
Fixed frequency array (P465).....	184	KTY84-130.....	117
Fixed frequency mode (P464) .....	183	<b>L</b>	
Flux feedback fact. CFC ol (P333) .....	163	Last current fault (P703) .....	210
Flying start (P520) .....	194	Last DC link voltage fault (P705) .....	210
Flying start offset (P522) .....	194	Last fault (P701).....	209
Flying start resolution (P521).....	194	Last frequency fault (P702).....	209
Function		Last voltage error (P704) .....	210
Bus I/O In Bits (P480) .....	185	Leakage current .....	260
Bus I/O Out Bits (P481) .....	185	LEDs .....	221
Setpoint inputs (P400) .....	166	Lifting equipment with brake .....	144
Functional safety .....	68	Limit	
Fuse.....	238	Field current controller (P317).....	160
<b>G</b>		Torque current controller (P314) .....	159
Gateway.....	89	Linear V/f characteristic curve .....	154
<b>H</b>		Load control .....	186
Heat sink temperature (P739) .....	215	Load control	
High-resistance grounding.....	63	Maximum (P525) .....	195
HRG system .....	63	Load control	
HTL encoder .....	75	Minimum (P526) .....	195
Hyst. Switchover CFC ol (P331).....	163	Load control	
Hysteresis of bus I/O Out bits (P483) .....	186	frequency (P527).....	196
<b>I</b>		Load control	
I component of PI controller (P414).....	173	delay (P528) .....	196
I <sup>2</sup> t limit .....	226, 231	Load control .....	197
I <sup>2</sup> t motor (P535) .....	198	Load drop.....	144
Incremental encoder .....	75	Load factory setting.....	195
Incremental encoder (P301).....	157	Load monitor .....	186
Informations .....	209	Load monitor .....	197
Input voltage (P728) .....	214	Load monitoring mode (P529) .....	196
Installation altitude.....	236	<b>M</b>	
Interference immunity .....	253	M12	
Internal EEPROM .....	133	Flange connector.....	97
Inverter name (P501).....	188	Plug connector .....	97
Inverter type (P743).....	216	Magnetization time (P558) .....	207
Inverter volt. range (P747).....	217	Maintenance .....	274
IP rating .....	36	Master - Slave.....	188

Master function output (P503) .....	189	Option monitoring (P120).....	147
Master function value (P502).....	188	Optional (mounting) slots .....	49
Max. freq. a-in 1/2 (P411).....	172	Oscillation damping (P217).....	153
Maximum frequency (P105) .....	142	Oscillation damping PMSM (P245).....	156
Mechanical power (P727).....	213	Outdoor installation .....	85
Memory module.....	86, 204	Output monitoring (P539) .....	200
Menu group .....	134	Output/size assignment .....	36
Messages .....	220, 221	Overcurrent .....	226, 231
Min. freq. a-in 1/2 (P410).....	172	Overvoltage switch-off .....	53
Min. freq. proc. ctrl. (P466).....	184	<b>P</b>	
Minimum frequency (P104) .....	142	P -component of PI controller (P413) .....	173
Mode		P factor torque limit (P111) .....	146
Analog input (P401) .....	168	P set last error (P706).....	210
Model code .....	32	Parameter identification .....	155
Modulation depth (P218) .....	153	Parameter identification (P220) .....	155
Monitoring		Parameter loss.....	227
Motor temperature .....	117	Parameter saving mode (P560).....	207
Montage		Parameter set (P100).....	141
SK 2xxE .....	38	Parameter set (P731).....	214
Motor		Parameterization options .....	87, 90
circuit (P207).....	150	PI process controller .....	247
cos phi (P206).....	150	PLC display value (P360) .....	165
Motor data.....	100, 148, 265, 268, 270	PLC functionality (P350) .....	164
Motor list (P200) .....	148	PLC integer setpoint (P355) .....	165
Motor load (P738).....	215	PLC long setpoint (P356).....	165
Motor mounting.....	43	PLC setpoint (P553).....	205
Motor temperature monitoring .....	117	PLC setpoint selection (P351) .....	164
Mounting of optional module .....	51	PLC status (P370).....	165
<b>N</b>		Plug connector	
Nameplate .....	32, 100	for control connection.....	97
No load current (P209) .....	151	for power connection.....	95
<b>O</b>		Plug connector .....	95
Offset analog output 1 (P417) .....	173	PMSM EMF voltage (P240) .....	155
Op. time last fault (P799).....	219	PMSM encoder offset (P334) .....	163
Operating display (P000).....	139	PMSM inductance (P241) .....	156
Operating displays.....	139	PMSM mass inertia (P246).....	156
Operating mode.....	238	PMSM peak current (P244) .....	156
Operating status .....	220, 221	Posicon .....	208
Operating time .....	212	Positioning .....	208
Operating time (P714) .....	212	Potentiometer Box function (P549).....	203
Operation.....	86	Potentiometers P1 and P2.....	110, 223



Power limitation .....	255	Reason VFD blocked (P700) .....	209
Power-up cycles .....	236	Reduced output power.....	255
Present		Relay	
cos phi (P725).....	213	set (P541).....	201
current (P719).....	213	Reluct. angle IPMSM (P243) .....	156
fault (P700) .....	209	Repairs.....	275
field current (P721) .....	213	Retrofitting the device .....	42
frequency (P716) .....	212	Rotary encoder function (P325).....	161
line current (P760) .....	219	Rotation direction .....	200
operating status (P700).....	209	Rotation direction mode (P540).....	200
setpoint frequency (P718).....	213	Rotor position identification mode (P336)...	164
speed (P717) .....	212	Rotor starting position detection (P330) .....	162
torque current (P720).....	213	<b>S</b>	
voltage (P722).....	213	Safe stop .....	68
warning (P700).....	209	Service .....	275
Process controller.....	167, 184, 247	Servo mode (P300).....	157
Process controller control limit (P415).....	173	Set analog output (P542).....	201
Process controller setpoint (P412) .....	173	Setpoint frequency processing .....	273
Process data Bus Out (P741).....	216	Setpoint processing .....	213, 246
Product standard .....	251	Setpoints .....	272
PT100 .....	117	Setpoints source (P510) .....	191
PT1000 .....	117	Size 4 motor cover insulating plate.....	40
Pulse disconnection.....	198, 199	SK BRE4-.....	56
Pulse disconnection (P537).....	199	SK BREW4- .....	56
Pulse frequency (P504) .....	189	SK BRI4- .....	53, 56
<b>Q</b>		SK BRW4-.....	56
Quick stop time (P426) .....	180	SK CU4-POT .....	98
<b>R</b>		SK TIE4-WMK- .....	44
Ramp smoothing (P106).....	143	Skip frequency 1 (P516) .....	193
Ramp time PI setpoint (P416) .....	173	Skip frequency 2 (P518) .....	193
Rated		Skip frequency range 1 (P517).....	193
motor current (P203).....	150	Skip frequency range 2 (P519).....	193
motor frequency (P201) .....	149	Slip compensation (P212).....	151
motor output (P205) .....	150	Slip error delay (P328).....	161
motor speed (P202) .....	149	Software version (P707) .....	210
motor voltage (P204) .....	150	Speed.....	214
Rated point		Speed controller I (P311).....	159
50 Hz.....	265, 268, 270	Speed controller P (P310) .....	159
87 Hz.....	269	Speed ctr. I release time (P321) .....	160
Ratio encoder (P326) .....	161	Speed slip error (P327).....	161
		Standardization	

Rated/actual values .....	272	Three-phase standard motor .....	148
Standardization		Time watchdog (P460).....	183
Analog output 1 (P419).....	175	Toroidal core .....	40
Bus I/O Out Bits (P482) .....	186	Torque	
State of relays (P711).....	212	current limit (P112).....	146
Static boost (P210) .....	151	Torque (P729).....	214
Statistics		Torque current controller I (P313).....	159
Customer error (P757).....	219	Torque current controller P (P312) .....	159
Grid fault (P752).....	218	Torque derivative action (P214).....	152
overcurrent (P750) .....	218	Torque disconnection limit (P534) .....	198
Overtemperature (P753).....	218	Total currents .....	66
Overvoltage (P751).....	218	<b>U</b>	
Parameter loss (P754) .....	218	UL/CSA approval .....	237
System faults (P755).....	219	Usage rate brake res. (P737) .....	215
Timeout (P756) .....	219	USS address (P512).....	192
Stator resistance (P208).....	151	USS baud rate (P511).....	191
Status		<b>V</b>	
Digital input (P708) .....	211	Vector control.....	154
DIP switches (P749) .....	218	Ventilation .....	39
Storage .....	274	VFC PMSM changeover freq. (P247) .....	156
Supervisor code (P003).....	140	VFD circuit breaker .....	260
Support .....	275	Voltage	
Switch over freq. CFC ol (P331).....	163	analog output (P710).....	212
System bus .....	193, 261	Voltage –d (P723).....	213
System bus tunneling .....	89	Voltage –q (P724).....	213
System error .....	230	<b>W</b>	
Systembus .....	191	Wall mounting .....	44
<b>T</b>		Warning messages .....	209, 231
Technical Data.....	61, 63, 236, 274	Warnings .....	209, 220, 221, 231
Technical Data		Watchdog.....	183
Variable frequency drives .....	236	Website .....	275
Technology unit .....	92	Weight.....	43
Telegram timeout (P513).....	192	Wiring guidelines.....	60
Temperature sensor .....	117		



**NORD DRIVESYSTEMS Group**

**Headquarters and Technology Centre**  
in Bargteheide, close to Hamburg

**Innovative drive solutions**  
for more than 100 branches of industry

**Mechanical products**  
parallel shaft, helical gear, bevel gear and worm gear units

**Electrical products**  
IE2/IE3/IE4 motors

**Electronic products**  
centralised and decentralised frequency inverters,  
motor starters and field distribution systems

**7 state-of-the-art production plants**  
for all drive components

**Subsidiaries and sales partners**  
**in 98 countries on 5 continents**  
provide local stocks, assembly, production,  
technical support and customer service

**More than 4,000 employees throughout the world**  
create customer oriented solutions

[www.nord.com/locator](http://www.nord.com/locator)

**Headquarters:**

**Getriebebau NORD GmbH & Co. KG**

Getriebebau-Nord-Straße 1  
22941 Bargteheide, Germany

T: +49 (0) 4532 / 289-0

F: +49 (0) 4532 / 289-22 53

[info@nord.com](mailto:info@nord.com), [www.nord.com](http://www.nord.com)

**Member of the NORD DRIVESYSTEMS Group**

