

Condition monitoring for predictive maintenance

The intelligent drive

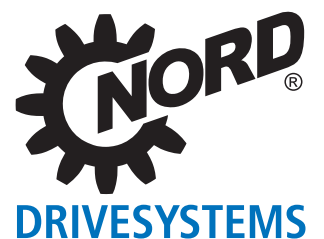

Complete drive solutions from a single source



NORD Delivers

NORD offers full-featured drive solutions that can tackle the toughest requirements. All components are carefully selected and precisely configured to meet your exact specifications. In the rare case that standard components won't meet your needs, our in-house engineering team will work with you to design custom components or a complete customized system.

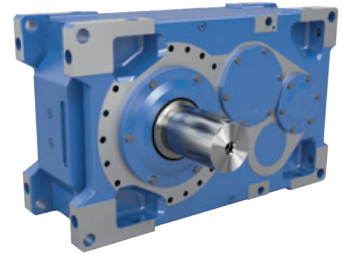

Reduce Lead Times and Decrease Inventory

- ▶ 25% of orders ship same day or next day with NO expedite fees
- ▶ 47% of orders ship within 5 working days
- ▶ 81% of orders ship in 2-3 weeks



Global Product Designs, Standards, and Support

- ▶ Innovative product range (one-stop shop)
- ▶ Global connected presence
- ▶ Mechanical and electrical application engineers ready to assist you
- ▶ Online resources

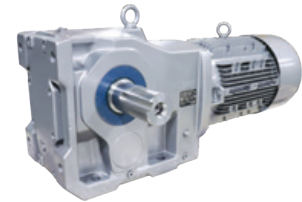

Increase Efficiency and Reduce Operation Costs

- ▶ First-class customer service and support, plus myNORD online tools
- ▶ Product flexibility through standard components and customizations
- ▶ Program personalization, such as weekly shipment schedules and custom nameplates
- ▶ Partner with a company that is easy to do business with and wants to see you succeed!



General

In the context of the NORD DRIVESYSTEMS Group's CONDITION MONITORING for PREDICTIVE MAINTENANCE, dynamically calculated and operating values captured by sensors are evaluated and provided for further processing. The variable frequency drive captures and processes operating values independently of an external controller using the variable frequency drive in combination with its integrated PLC. The results are continuously provided via the PLC output parameters and can be sent and saved to a local dashboard via Industrial Ethernet (e.g. PROFINET IO) for visualization. In addition to all internal measuring values, each drive unit can be used to evaluate external sensors such as a

temperature sensor (PT1000 in the motor winding) or a vibration transmitter. Processing of measurement values and preparation of output signals is carried out dynamically and individually in each variable frequency drive with the aid of its integrated PLC. There is also the option of defining threshold values which trigger an alarm if they are exceeded. All output signals from the variable frequency drive's data processing are also provided for further processing via the bus interface and are read out via the dashboard. The dashboard is the data storage unit for all captured operating drive values. Due to the detailed visualization of each drive, it is also the interactive interface to the operator.

Warning and alarm messages

Each drive can signal its CONDITION MONITORING status, e.g. with an external signal column with the colors green, yellow, and red.

- ▶ Green: No warnings and errors
- ▶ Yellow: At least one of the four measurements has exceeded the warning limit or a warning is present in the variable frequency drive
- ▶ Red: At least one of the four measurements has exceeded the alarm limit or the variable frequency drive has switched to the error state

In parallel, the warning and alarm messages of all drives are visualized on the dashboard.

NORD dashboard: Graphic overview of the application

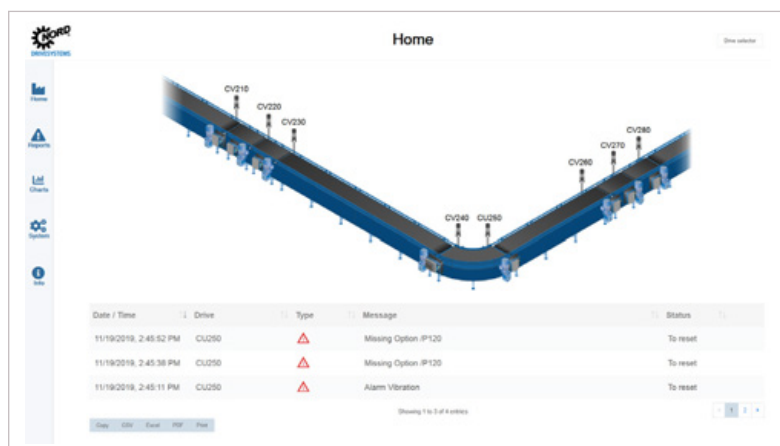

Condition monitoring for predictive maintenance

For condition monitoring, drive and status data are recorded periodically or continuously to optimize the operational safety and efficiency of machines and plants. Condition monitoring provides valuable information for predictive maintenance with the goal to service equipment proactively.

Advantages for our customers

- ▶ Early detection and avoidance of undesired operating conditions
- ▶ Time-based maintenance is replaced by status-based maintenance
- ▶ Machinery and plant downtimes can be planned based on drive and process data
- ▶ Reduction of service and material costs
- ▶ Longer service life of components and machines
- ▶ Increase in system availability
- ▶ Avoidance of unplanned downtime
- ▶ Predictable and cost-optimized repairs

Condition Monitoring

The Industrial Internet of Things (IIoT) focuses on internet usage in industrial processes and procedures. IIoT aims at increasing operational efficiency, reducing costs, and speeding up processes. Sensors and sensor data play a central role for condition monitoring and predictive maintenance.

- ▶ Condition monitoring solutions for predictive maintenance systems are integrated into the VFD
- ▶ System is IIoT / Industry 4.0 READY!
- ▶ Available for decentralized and control cabinet solutions

Sensors

- ▶ Interface for digital and analog sensors
- ▶ Virtual sensors – the PLC can calculate information such as the optimal oil change time

Communication Interfaces

- ▶ Threshold values or general status information can be communicated externally (via normal Industrial Ethernet dialects)

Integrated PLC

- ▶ Local pre-processing of data within the integrated PLC
- ▶ Pre-processing of threshold values

Predictive Maintenance

Information from condition monitoring can be transferred to predictive maintenance.

Drive-based approach

- ▶ Sensorless determination of the optimum oil change time based on virtual oil temperature
- ▶ Pre-processing of drive data in the integrated PLC
- ▶ Offering the data to the customer via all common interfaces

Gear unit oil temperature curve

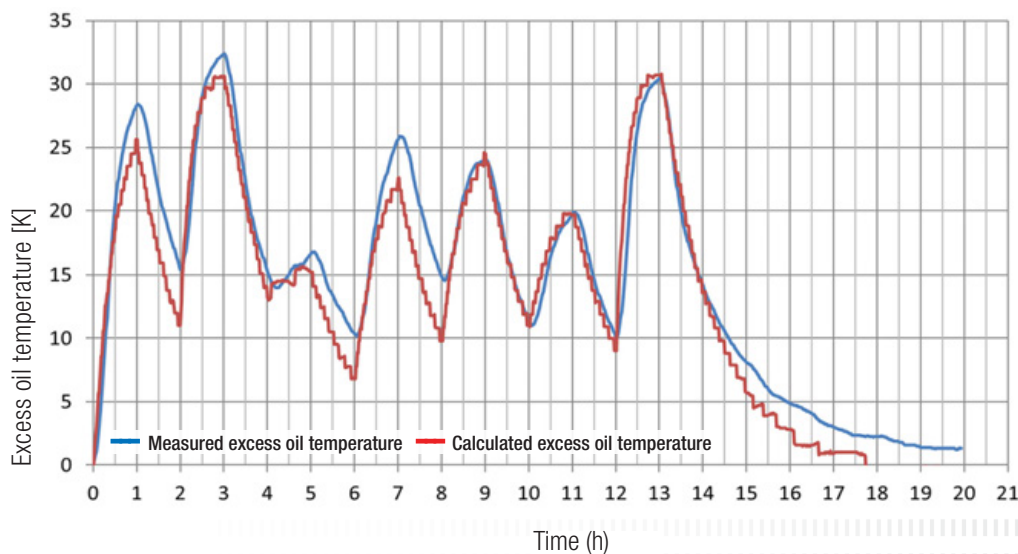

Optimum oil change time

- ▶ Gear unit parameters and specific operational parameters make it possible to precisely calculate the oil change time
- ▶ The NORD solution is based on the fact that the oil temperature is a key factor for oil aging in gear units
- ▶ A hardware temperature sensor is not needed, because virtual sensors calculate the current oil temperature continuously by way of drive-specific parameters
- ▶ The existing VFD from NORD is used as an evaluation unit. The algorithm runs in the internal PLC

Condition monitoring for predictive maintenance

Visualization of defined drive information parameters

Actual speed	Motor speed
Actual voltage	Output voltage (VFD)
Vibration	Vibration levels
Remaining oil lifetime	Remaining useful life of the gear oil
Drive status	Drive condition
Running time	Enabling time of the VFD

Actual current	VFD output current
Mechanical power	Mechanical power of the motor
Motor temperature	Motor temperature
Actual heat sink temperature	Temperature on VFD heat sink
Operation time	Length of operation, i.e. VFD is switched on
State	VFD condition

VFD = Variable Frequency Drive

View of the transferred information parameters for a drive

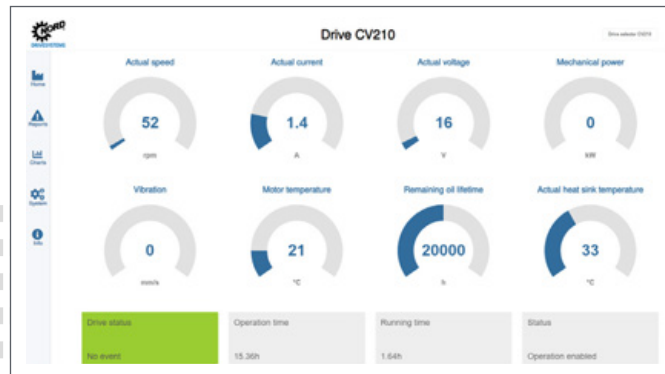

Scope of functions

A series of three function ranges are available for condition monitoring (CM). The NORD SMART OIL CHANGE function (SOC) is available as an option.

CM1

CM1 includes transfer of selected information parameters from the variable frequency drive to a database in a local IPC. The integrated PLC of the variable frequency drive is not used. An Ethernet interface in the variable frequency drive is necessary to transfer the data to the local IPC.

CM2

CM2 additionally uses the integrated PLC of the variable frequency drive for threshold-based evaluation of external sensors (vibration sensor and motor temperature) or drive information parameters. The NORD SMART OIL CHANGE function is available as an option.

CM3

CM3 provides visualization of the data for each drive in a proprietary NORD dashboard.

SOC

The optional SOC function enables determination of the optimum oil change time on the basis of the virtual oil temperature. The algorithm runs in the integrated PLC. At present, this function is available for 2-stage bevel gear units.

The data is updated in real time in the charts. It is also possible to view data from the past via a calendar function.

Detailed chart, available for all of the values shown above

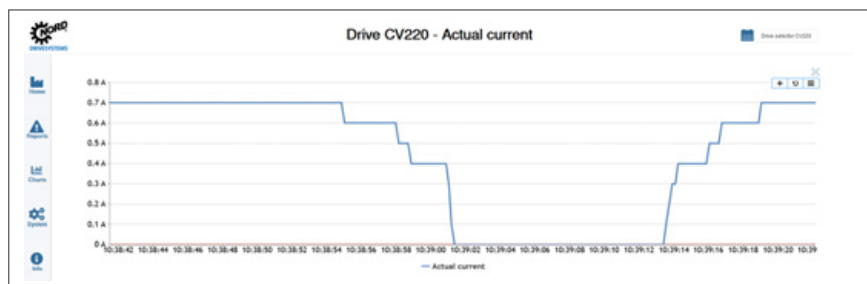
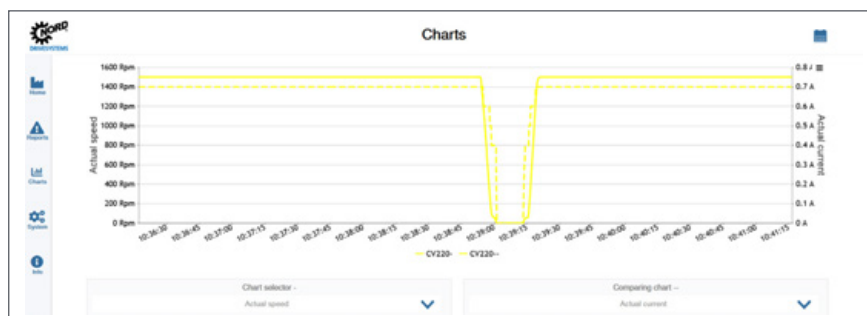
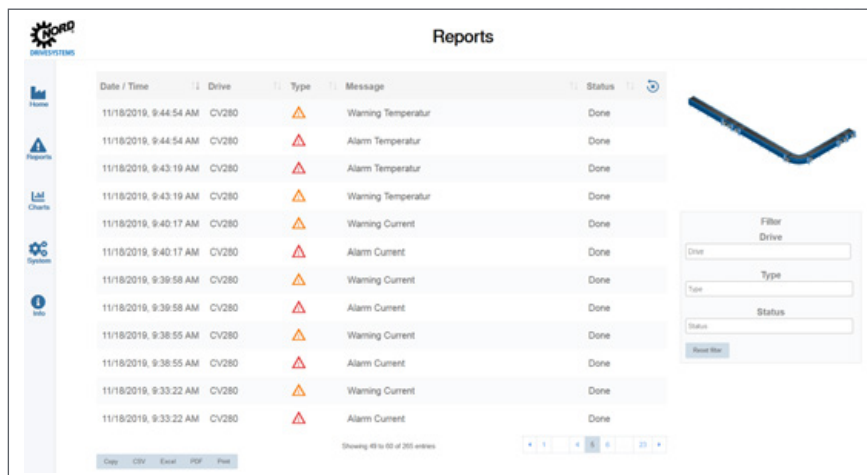

Chart selector: Comparison of two parameters between several drives



Reports: Display of pending or acknowledged faults and warning messages



Date / Time	Drive	Type	Message	Status
11/18/2019, 9:44:54 AM	CV280	Warning	Warning Temperature	Done
11/18/2019, 9:44:54 AM	CV280	Alarm	Alarm Temperature	Done
11/18/2019, 9:43:19 AM	CV280	Alarm	Alarm Temperature	Done
11/18/2019, 9:43:19 AM	CV280	Warning	Warning Temperature	Done
11/18/2019, 9:40:17 AM	CV280	Warning	Warning Current	Done
11/18/2019, 9:40:17 AM	CV280	Alarm	Alarm Current	Done
11/18/2019, 9:39:58 AM	CV280	Warning	Warning Current	Done
11/18/2019, 9:39:58 AM	CV280	Alarm	Alarm Current	Done
11/18/2019, 9:38:55 AM	CV280	Warning	Warning Current	Done
11/18/2019, 9:38:55 AM	CV280	Alarm	Alarm Current	Done
11/18/2019, 9:33:22 AM	CV280	Warning	Warning Current	Done
11/18/2019, 9:33:22 AM	CV280	Alarm	Alarm Current	Done

Parameterization on the variable frequency drive

In general, these functions are fixed. The user can only adjust the alarm threshold values. The threshold values for warning messages are derived from the alarm threshold values on a percentage basis.

Condition monitoring for predictive maintenance

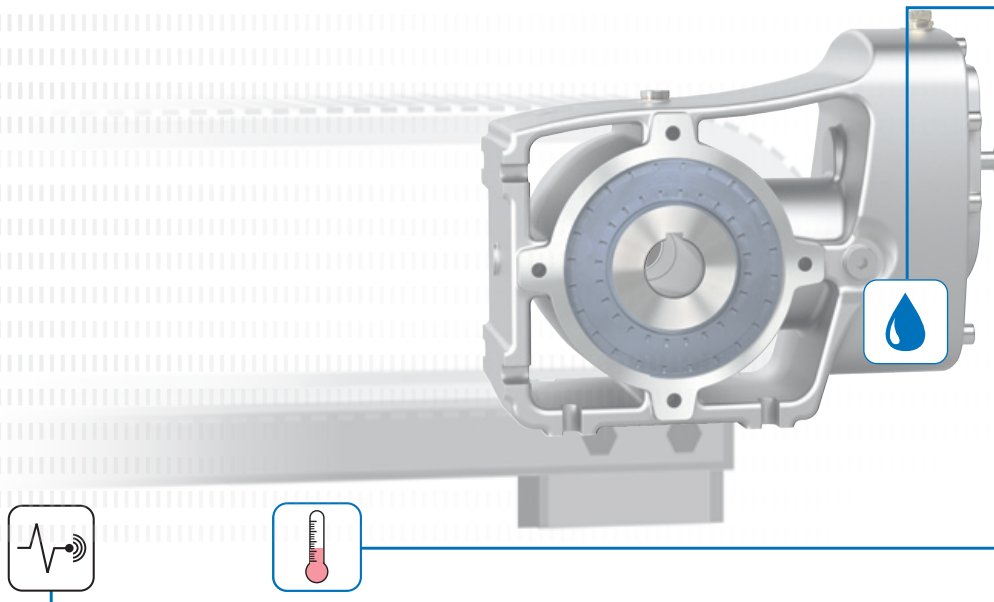

System vibration sensor

- ▶ NORD qualified sensors
- ▶ Customer-specific sensors can be connected (analog/digital)



Temperature sensor

- ▶ PT1000-based motor temperature sensor
- ▶ Ambient or system temperature



Oil change

- ▶ Determination of the optimal time for oil change on the basis of the virtual oil temperature
- ▶ The algorithm is executed in the integrated PLC



Drive parameters

- ▶ Readout of the drive system parameters
- ▶ Basis for virtual sensors



Integrated PLC

- ▶ Pre-processing of drive-specific parameters and drive-related sensors
- ▶ Evaluation of drive conditions

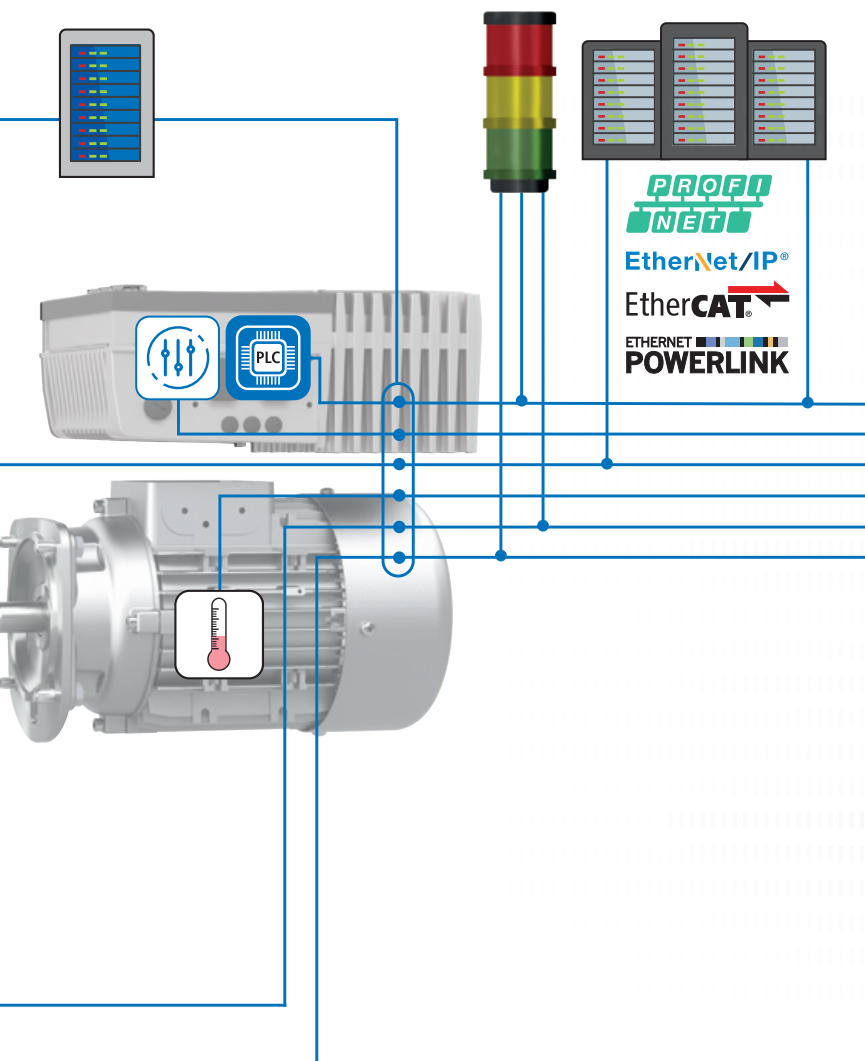

Beacon signal

- ▶ Local display of drive conditions
- ▶ Scalable display



Local dashboard

- ▶ Display of drive and system data



Local data management

- ▶ Preparation of drive data for drive and system analysis
- ▶ Condition monitoring



Higher level PLC

- ▶ Processing of condition monitoring information by the customer
- ▶ Merging of condition monitoring data with process data

Condition monitoring for predictive maintenance

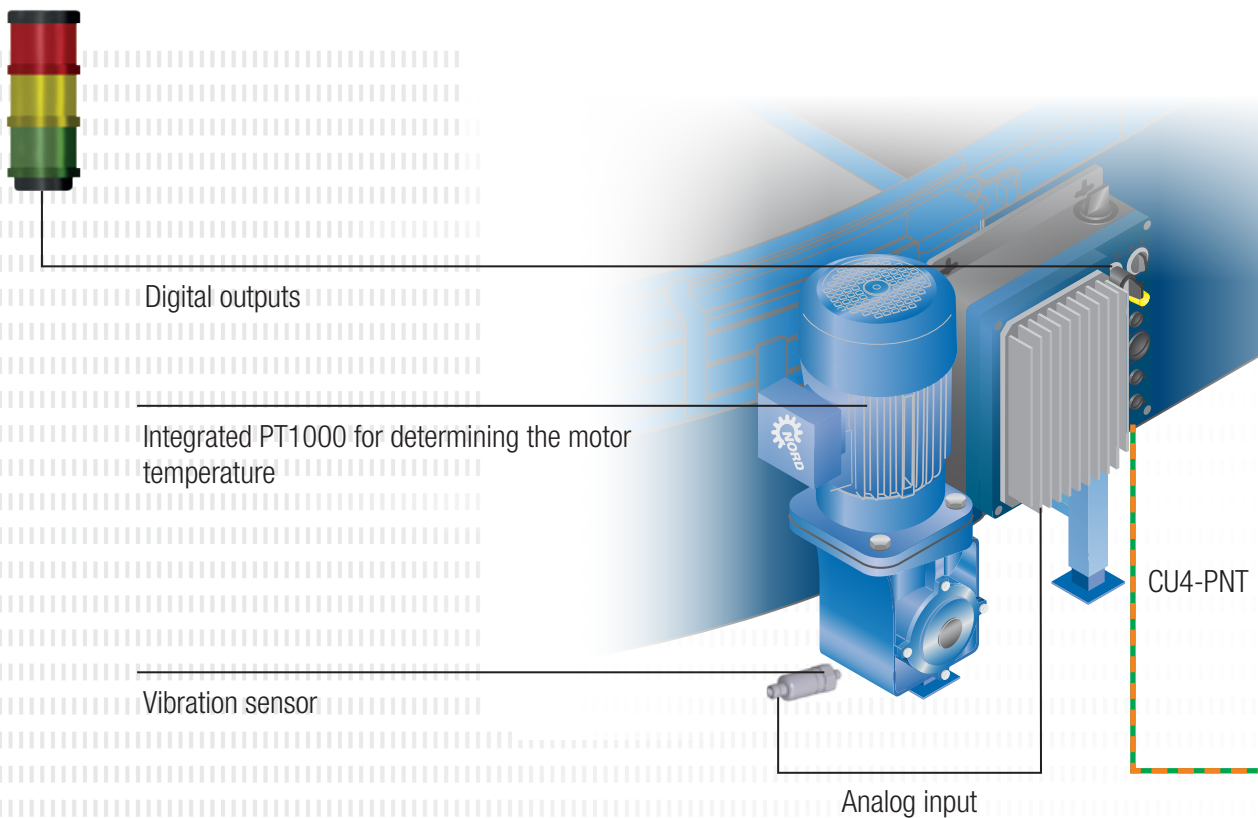

Condition monitoring at an airport

At an international airport, NORD DRIVESYSTEMS has retrofitted a pilot system in order to collect condition monitoring data from selected drives. The conveyors within the system are equipped with NORD gear units, motors, and NORDAC *LINK* variable frequency drives.

The motors feature a PT1000 to determine the motor temperature. A vibration sensor attached to each gear motor monitors the vibration velocity of the drive. Both sensors are analog sensors and thus could be connected directly to the analog inputs of the NORDAC *LINK*.

This solution's special feature is that the NORD variable frequency drive's integrated PLC is used to evaluate threshold values for vibration, motor temperature, and motor current, as well as generate corresponding warning and alarm messages based on that data. In addition, the NORD SMART OIL CHANGE algorithm runs within the integrated PLC to determine the oil change interval of the 2-stage bevel gear units.

In this application, the complete logic for the NORD Condition Monitoring for Predictive Maintenance solution has been implemented within the variable frequency drive's integrated PLC.

Local PC (dashboard)

Integrated PLC:

- ▶ NORD SMART OIL CHANGE

Threshold values defined for:

- ▶ Current
- ▶ Motor temperature
- ▶ Vibration

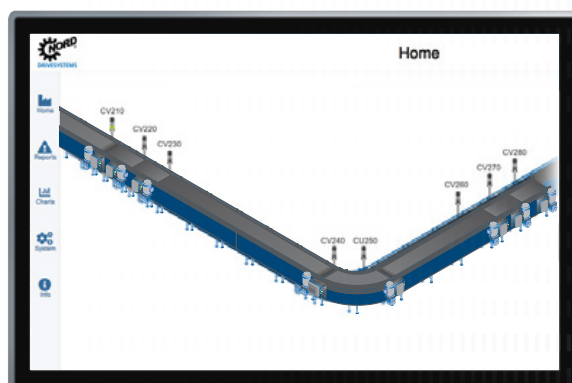

PLC



UDP channel

Ethernet-based

Additionally, a communication interface to the higher level PROFINET IO controller is in use. Via the PROFINET IO interface, several drive info parameters are transferred to a PC. With its touch screen, the PC also serves as NORD's dashboard where the values that have been stored in a local database can be displayed. Messages on exceeded threshold values, as well as general drive information parameters can easily be displayed here. Data from the past can also be displayed quickly and easily via a history function.

An external signal beacon light, connected and supplied via the NORDAC *LINK*, is also a part of this system. It provides a visual queue for the condition monitoring status. Green – no messages, Orange – warning threshold exceeded, Red – alarm threshold exceeded. Warning or alarm messages that have occurred can also be directly acknowledged via a reset button on the dashboard.

This solution allowed for existing gear units to be modified to provide condition monitoring for predictive maintenance functionality, making the transition to this proactive maintenance solution very cost effective.

Condition monitoring for predictive maintenance

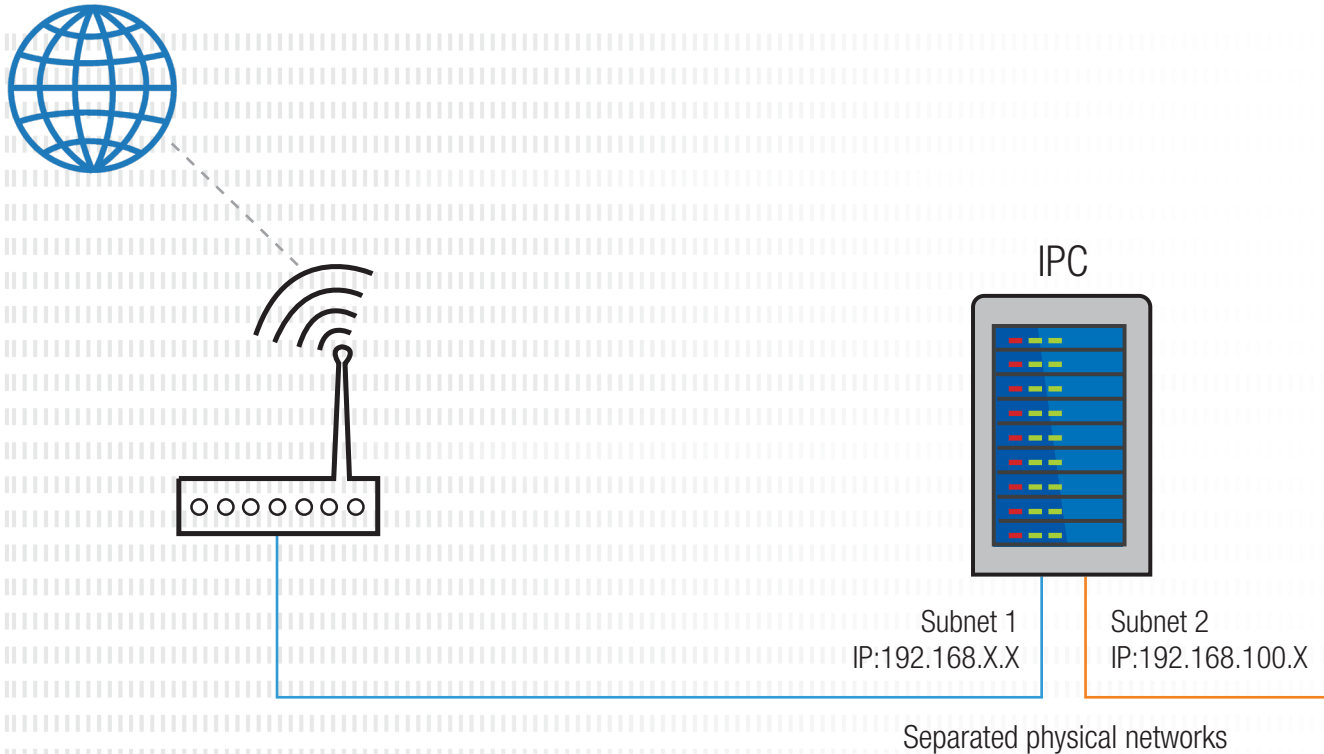

Condition monitoring in a parcel distribution center

NORD supplied a software solution for a parcel distribution center to upgrade their existing system with condition monitoring functionality. By adding an Industrial PC (IPC), it became possible to collect all drive information parameters and forward it to a customer cloud. The system is equipped with 96 NORD drives, consisting of gear units, motors, and variable frequency drives from the NORDAC *FLEX* series. PROFINET IO was used as the communication interface. In addition to participants on the PROFINET network, up to three participants could be connected to a VFD via the system bus. The IPC was subsequently installed in a control cabinet.

In addition to a cybersecurity concept using Windows firewall, Windows security updates, and an antivirus program, the IPC is equipped with two physically separated network cards. One is the interface to the customer application via which the drive data is collected. The other provides the interface to the customer cloud. This makes the system highly secure.

The IPC queries all previously defined parameters from all variable frequency drives via the UDP channel of the PROFINET IO telegram. Additionally, the local database is protected by HTTPS, a user name, and a password.

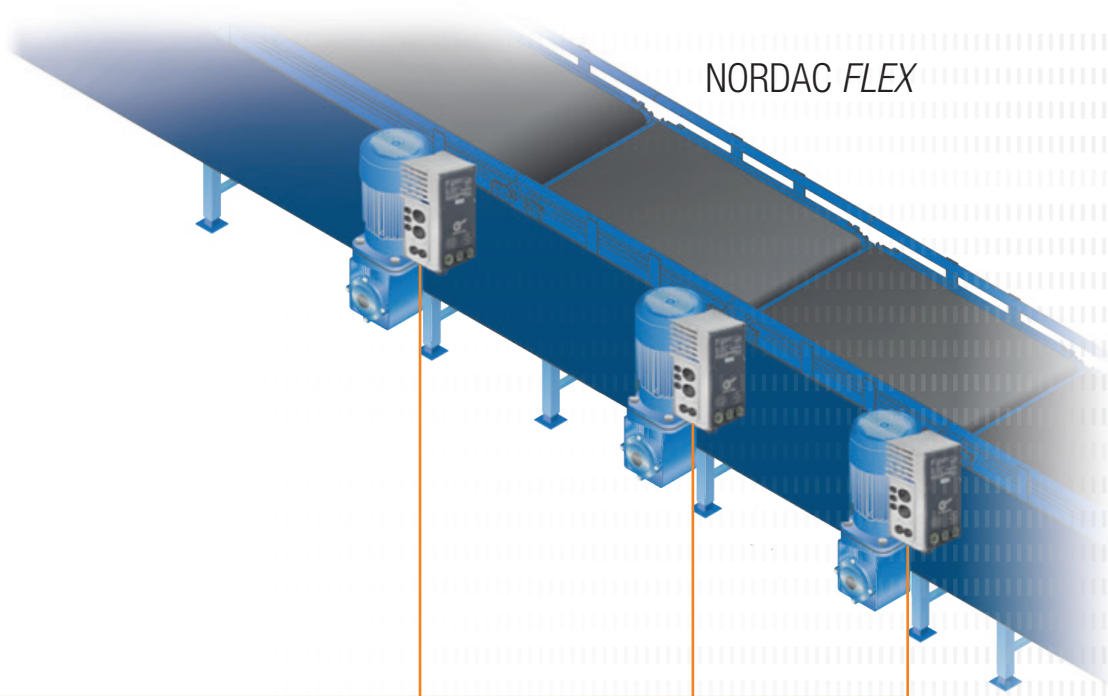

The following drive information parameters are collected:

- ▶ Operating time
- ▶ Actual voltage
- ▶ Running time
- ▶ Mechanical power
- ▶ Actual speed
- ▶ Heat sink temperature of the variable frequency drive
- ▶ Actual current

The data is stored in the database on the local IPC. After this, a push function enables the data to be directly transferred into a customer cloud. This solution enabled the customer to seamlessly integrate condition monitoring for predictive maintenance into their existing system.

Condition monitoring for predictive maintenance

Integrated PLC

- ▶ Available for all NORD variable frequency drives and motor starters
- ▶ Performs drive-related functions
- ▶ Integrates drive-related actuators and sensors
- ▶ Parameter access
- ▶ Access to Industrial Ethernet or field bus data
- ▶ Implementation of application-specific functions

The right PLC software architecture for your solution

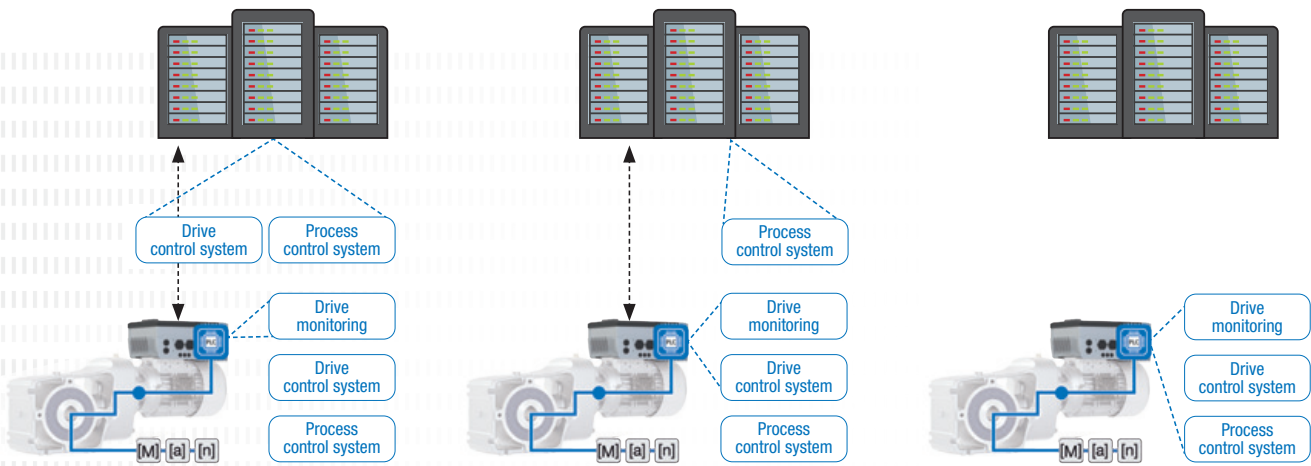

NORDCON APP

- ▶ Dashboard based visualization for drive monitoring and fault diagnosis
- ▶ Parameterization with help function and rapid access to parameters
- ▶ Oscilloscope function

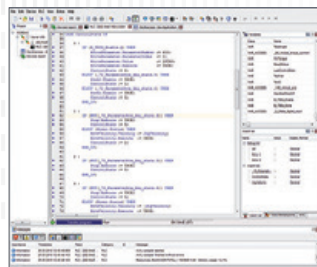

NORDCON software

- ▶ User-friendly parameterization and programming of several drives
- ▶ PLC editor according to IEC 61131-3, supporting Structured Text (ST), Instruction List (IL) and PLCopen Motion Control library
- ▶ Multi-axis access via Ethernet tunnelling

NORDAC PRO - Control cabinet variable frequency drive



- ▶ The next generation of control cabinet VFDs
- ▶ Compact size
- ▶ Innovative, extremely flexible communication and interface concept, functional expansion with optional modules
- ▶ Power range up to 200 HP
- ▶ Control cabinet installation
- ▶ IP20

NORDAC LINK - Decentralized variable frequency drive



- ▶ Field distributor for versatile, decentralized installation
- ▶ Flexible configuration, functions, and application
- ▶ Fast commissioning through high level of plug-in capability, system servicing through integrated maintenance switch, and local manual control facility
- ▶ Power range up to 10 HP
- ▶ Field installation
- ▶ IP55/IP66

NORDAC FLEX - Decentralized variable frequency drive



- ▶ Decentralized drive unit with versatile installation options
- ▶ Simple commissioning and maintenance through extensive plug-in capability and simple parameter transfer via EEPROM
- ▶ Power range up to 3 HP
- ▶ Wall or motor mounting
- ▶ IP55/IP66

NORDAC BASE Decentralized variable frequency drive



- ▶ Economical decentralized VFD for simple drive applications
- ▶ Low installation costs as well as robust design for simple installation outside of the control cabinet
- ▶ Power range up to 3 HP
- ▶ Wall or motor mounting
- ▶ IP55/IP66 /IP69K

ENGINEERED & MADE in 
GERMANY

Ordering is Easy With myNORD Online Tools!



- ▶ Obtain drawing files direct from quote configuration
- ▶ Effortlessly select & configure customized drive solutions
- ▶ Create quotes with account-specific net pricing
- ▶ Order-specific documentation
- ▶ 24/7/365 order tracking
- ▶ Select and order spare parts

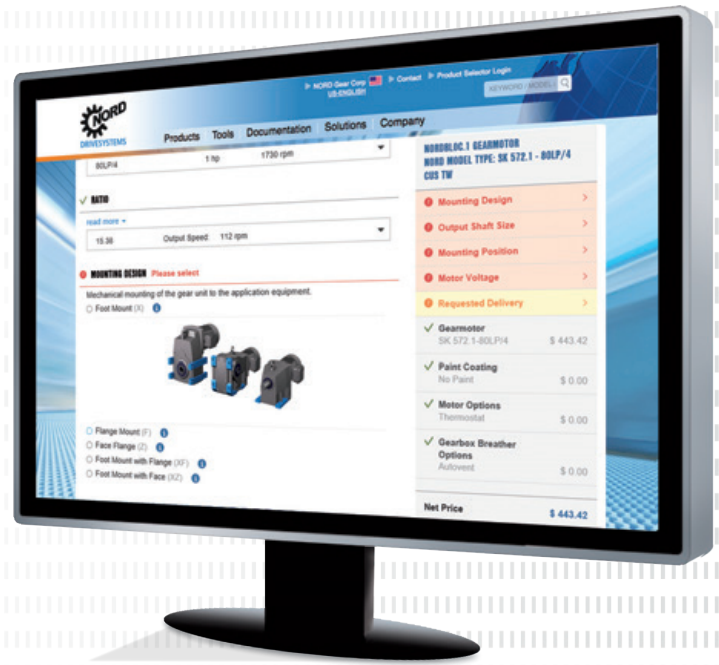

Register now at myNORD.com!



www.nord.com

NORD Gear Corporation - US

Waunakee, WI
800 NORD Drive
Waunakee, WI 53597
Tel. 888.314.6673
info.us@nord.com

Corona, CA
1180 Railroad St.
Corona, CA 92882
Tel. 888.314.6673
info.us@nord.com

Charlotte, NC
300E Forsyth Hall Dr.
Charlotte, NC 28273
Tel. 888.314.6673
info.us@nord.com

NORD Gear Limited - Canada

Brampton, ON
41 West Drive
Brampton, ON L6T4A1
Tel. 800.668.4378
info.ca@nord.com

NORD DRIVE SYSTEMS SA DE CV

Queretaro, Mexico
Av. Industria Textil B.6
Parque Industrial PYME, Huimilpan
QRO - Mexico 76950
Tel. 52 442 688 7110
info.mx@nord.com