



BU 0180 – en

NORDAC *BASE* (SK 180E series)

Users Manual for Frequency Inverters





Read document and keep for future reference

Read this document carefully prior to performing any work on the device and putting it into operation. It is essential to read and observe the instructions in this document. They serve as the prerequisite for smooth and safe operation and the fulfilment of any warranty claims.

Contact Getriebebau NORD GmbH & Co. KG if your questions regarding the handling of the device are not answered in this document or if you require further information.

The German version of this document is the original. The German document is always decisive. If this document is available in other languages, these will be translations of the original document.

Keep this document in the vicinity of the device so that it is available if required.

Use the version of this documentation that is valid for your device at the time of delivery. You can find the currently valid version of the documentation under www.nord.com.

Please also note the following documents:

- Catalogue “NORDAC electronic drive technology” ([E3000](#)),
- Documentation for optional accessories
- Documentation for equipment which is attached or provided.

Please contact [Getriebebau NORD GmbH & Co. KG](#) if you require further information.

Documentation

Title:	BU 0180		
Order no.:	6071802		
Series:	SK 1x0E		
Device series:	SK 180E, SK 190E		
Device types:	SK 1x0E-250-112-O ... SK 1x0E-750-112-O	0.25–0.75 kW,	1~ 110–120 V, Out: 230 V
	SK 1x0E-250-323-B ... SK 1x0E-111-323-B	0.25–1.1 kW,	1/3~ 200–240 V
	SK 1x0E-151-323-B	1.5 kW,	3~ 200–240 V
	SK 1x0E-250-340-B ... SK 1x0E-221-340-B	0.25–2.2 kW,	3~ 380–480 V

Version list

Title, Date	Order number	Software version of device	Remarks
BU 0180 , June 2013	6071802 / 2313	V 1.0 R0	First issue.
BU 0180 , February 2014	6071802 / 0914	V 1.0 R1	Among others: <ul style="list-style-type: none"> • General corrections • Bus options added • Adaptation of individual technical data • Device 1.5 kW, 3~ 230 V added • Revision of EMC chapter, incl. supplement of EC Declaration of Conformity
BU 0180 , June 2014	6071802 / 2314	V 1.0 R1	Among others: <ul style="list-style-type: none"> • General corrections • Correction of terminal names from "AGND ,12" to "GND/0V ,40"
BU 0180 , March 2015	6071802 / 1115	V 1.0 R1	<ul style="list-style-type: none"> • UL group fuse protection • Braking resistor
BU 0180 , March 2015	6071802 / 1315	V 1.0 R1	<ul style="list-style-type: none"> • ATEX
BU 0180 , March 2016	6071802 / 1216	V 1.2 R0	Among others: <ul style="list-style-type: none"> • General corrections • Structural modifications to the document • New parameters: P240–247, 300, 310–320, 330, 331, 333, 350–370, 746 • Adaptation of parameters: P001, 003, 105, 108, 109, 110, 200, 219, 401, 418, 420, 434, 480, 481, 502, 509, 513, 535, 740, 741 • PMSM • PLC • IP69K • New presentation of scope of delivery / accessory overview • Revision of chapter "UL/cUL", e.g. for CSA: voltage limitation filter no longer required (SK CIF) → Module removed from document • Revision of "Braking resistor" chapter

Title, Date	Order number	Software version of device	Remarks
			<ul style="list-style-type: none"> • Display and operation → Connection of multiple devices to one parametrisation tool (tunnelling via system bus) • Commissioning → Selection of operating mode for motor control added • Revision of “Technical / electrical data” • Addition of an FAQ list for operational problems • Removal of detailed descriptions of accessories and reference to appropriate technical information • Update of EC/EU conformity declarations
BU 0180 , October 2018	6071802 / 4118	V 1.2 R1	Among others: <ul style="list-style-type: none"> • General corrections • Revision of safety information • Revision of warning information • Adaptations for ATEX, outdoor installation and braking resistors • Addition of EAC Ex • Revision of wall-mounting kits and adapter kits for motor mounting • Adaptation of parameters: P300, 553, 543, 556, 557 • Parameters: P331, 332, 333 without function, → deleted • Update of EC/EU conformity declarations • Addition of temperature sensors (PT100, PT1000) • Correction of standardisation of setpoints and actual values • Motor data extended with 100 Hz characteristic curve
BU 0180 , December 2020	6071802 / 5020	V 1.3 R0	Among others: <ul style="list-style-type: none"> • General corrections • Corrections with adaptation for IP66 design • Adaptation of parameters: P245, 434, 553, 558 • Error message E7.0 / E7.1 added
BU 0180 , July 2021	6071802 / 3021	V 1.3 R0	<ul style="list-style-type: none"> • Update of “Standards and approvals” • Update of EU Declaration of Conformity • Supplementation of data according to the Ecodesign Directive
BU 0180 , December 2021	6071802 / 5021	V 1.3 R0	Among others: <ul style="list-style-type: none"> • General corrections • Completion of name plate data
BU 0180 , September 2024	6071802 / 3824	V 1.3 R0	Among others: <ul style="list-style-type: none"> • General corrections • Supplementation of disposal notes • Removal of protection class IP69K

Table 1: Version list

Copyright notice

As an integral component of the device described here, this document must be provided to all users in a suitable form.

Any editing or amendment or other utilisation of the document is prohibited.

Publisher

Getriebebau NORD GmbH & Co. KG

Getriebebau-Nord-Straße 1 • 22941 Bargteheide, Germany • <http://www.nord.com>

Fon +49 (0) 45 32 / 289-0 • Fax +49 (0) 45 32 / 289-2253

Member of the NORD DRIVESYSTEMS Group

Table of Contents

1	General	12
1.1	Overview	12
1.2	Delivery	14
1.3	Scope of delivery.....	14
1.4	Safety, installation and application information	15
1.5	Warning and hazard information	19
1.5.1	Warning and hazard information on the product.....	19
1.5.2	Warning and hazard information in the document	20
1.6	Standards and approvals	21
1.6.1	UL and CSA approval	23
1.7	Type code / nomenclature.....	25
1.7.1	Name plate	26
1.7.2	Frequency inverter type code	27
1.7.3	Type code for option modules	27
1.7.4	Type code, connection unit for technology unit.....	28
1.7.5	Adapter Unit type code	28
1.8	Power rating / Motor size	28
1.9	Version in protection class IP55, IP66.....	29
2	Assembly and installation	30
2.1	Installation SK 1x0E.....	30
2.1.1	Work procedures for motor installation	31
2.1.1.1	Adapters for different motors	31
2.1.1.2	Dimensions, SK 1x0E mounted on motor	33
2.1.2	Wall mounting.....	34
2.2	Installation of optional modules	36
2.2.1	Option locations on device	36
2.2.2	Installation of internal customer unit SK CU4-... (installation)	38
2.2.3	Installation of external technology units SK TU4-... (attachment).....	39
2.3	Braking resistor (BW) - (from size 2).....	40
2.3.1	Internal braking resistor SK BRI4-.....	40
2.3.2	External braking resistor SK BRE4-... / SK BRW4-... / SK BREW4-.....	41
2.4	Electrical Connection	43
2.4.1	Wiring guidelines	45
2.4.2	Electrical connection of power unit	46
2.4.2.1	Mains supply (L1, L2(/N), L3, PE)	46
2.4.2.2	Motor cable	48
2.4.2.3	Braking resistor (+B, -B) – (from size 2)	48
2.4.3	Electrical connection of the control unit	49
2.4.3.1	Control terminal details	50
2.5	Operation in potentially explosive environments	53
2.5.1	Operation in potentially explosive environments - ATEX zone 22 3D.....	53
2.5.1.1	Modification of the device for compliance with category 3D	53
2.5.1.2	Options for ATEX Zone 22, category 3D	55
2.5.1.3	Maximum output voltage and torque reduction	56
2.5.1.4	Commissioning information	57
2.5.1.5	EU conformity declaration - ATEX	59
2.6	Outdoor installation	60
3	Display, operation and options	61
3.1	Control and parametrisation options	62
3.1.1	Connection of multiple devices to one parametrisation tool.....	63
3.2	Optional modules	64
3.2.1	Internal customer interfaces SK CU4-... (installation of modules).....	64
3.2.2	External technology units SK TU4-... (module attachment)	65
3.2.3	plug connectors	68
3.2.3.1	Plug connectors for power connections	68
3.2.3.2	Plug connectors for control connection	69
3.2.4	Potentiometer adapter, SK CU4-POT.....	71
4	Commissioning	72

4.1	Factory settings.....	72
4.2	Selecting the operating mode for motor control	73
4.2.1	Explanation of the operating modes (P300)	73
4.2.2	Overview of control parameter settings	74
4.2.3	Motor control commissioning steps	74
4.3	Starting up the device	76
4.3.1	Connection	76
4.3.2	Configuration	76
4.3.2.1	Parameterisation	76
4.3.2.2	DIP switches (S1, S2)	77
4.3.3	Commissioning examples.....	78
4.4	Temperature sensors	79
4.5	AS Interface (AS-i)	82
4.5.1	The bus system	82
4.5.2	Features and technical data	82
4.5.3	Bus structure and topology	83
4.5.4	Commissioning	84
4.5.4.1	Connection	84
4.5.4.2	Displays	85
4.5.4.3	Configuration	85
4.5.4.4	Addressing	86
4.5.5	Certificate	87
5	Parameter.....	88
5.1	Parameter overview	90
5.2	Description of parameters	93
5.2.1	Operating displays.....	93
5.2.2	Basic parameters.....	95
5.2.3	Motor data / Characteristic curve parameters.....	102
5.2.4	Control parameters.....	110
5.2.5	Control terminals	115
5.2.6	Additional parameters.....	134
5.2.7	Information.....	150
6	Operating status messages	161
6.1	Display of messages	161
6.2	Diagnostic LEDs on device	162
6.3	Messages.....	163
6.4	FAQ operational problems	171
7	Technical data	173
7.1	General frequency inverter data.....	173
7.2	Technical data for determining the energy efficiency level.....	174
7.3	Electrical data	176
7.3.1	Electrical data 1~ 115 V.....	177
7.3.2	Electrical data 1/3~230 V.....	178
7.3.3	Electrical data 3~ 400 V.....	180
8	Additional information.....	182
8.1	Setpoint processing.....	182
8.2	Process controller	183
8.2.1	Sample application: Process controller.....	183
8.2.2	Process controller parameter settings	184
8.3	Electromagnetic compatibility (EMC)	185
8.3.1	General Provisions	185
8.3.2	EMC evaluation	186
8.3.3	EMC of device	187
8.3.4	Declarations of Conformity	189
8.4	Reduced output power	191
8.4.1	Increased heat dissipation due to pulse frequency.....	191
8.4.2	Reduced overcurrent due to time	192
8.4.3	Reduced overcurrent due to output frequency.....	193
8.4.4	Reduced output current due to low voltage	194
8.4.5	Reduced output current due to heat sink temperature.....	194
8.5	Operation on the RCD.....	195
8.6	System bus	196

8.7	Energy efficiency optimisation when operating ASMs.....	199
8.8	Motor data – characteristic curves (Asynchronous motors)	200
8.8.1	50 Hz characteristic curve	200
8.8.2	87 Hz characteristic curve (only 400V devices).....	203
8.8.3	100 Hz characteristic curve (only 400 V devices).....	205
8.9	Motor data – characteristic curves (synchronous motors).....	206
8.10	Scaling of set-/actual values	207
8.11	Definition of set and actual value processing (frequencies).....	208
9	Maintenance and servicing information.....	209
9.1	Maintenance information.....	209
9.2	Service notes	210
9.3	Disposal	211
9.3.1	Disposal according to German law	211
9.3.2	Disposal outside of Germany.....	211
9.4	Abbreviations	212

List of illustrations

Figure 1: Device with internal SK CU4-.....	13
Figure 2: Device with external SK CU4-.....	13
Figure 3: Name plate	26
Figure 4: Example of motor size adaptation	32
Figure 5: Option locations, size 1	36
Figure 6: Option locations, size 2	36
Figure 7: Jumpers for mains adaptation	47
Figure 8: internal customer units SK CU4 ... example	64
Figure 9: external technology units SK TU4-... (example).....	65
Figure 10: Examples of devices with connectors for connecting the power.....	68
Figure 11: Wiring diagram SK CU4-POT, example SK 1x0E	71
Figure 12: Connecting terminals AS-i	84
Figure 13 Setpoint processing	182
Figure 14: Flow chart: Process controller	183
Figure 15: Sample application: Dancing roller	184
Figure 16: Wiring recommendation.....	188
Figure 17: Heat losses due to pulse frequency	191
Figure 18: Reduced output current due to low voltage	194
Figure 19: Energy efficiency due to automatic flux optimisation	199
Figure 20: Characteristic curve 50 Hz	200
Figure 21: 87 Hz characteristic curve	203
Figure 22: Characteristic curve 100 Hz	205

List of tables

Table 1: Version list.....	4
Table 2: Warning and hazard information on the product.....	19
Table 3: Standards and approvals.....	21
Table 4: Standards and approvals for explosion hazard environments	22
Table 5: Assignment of braking resistors to frequency inverter	42
Table 6: Connection data	46
Table 7: external bus modules and IO extensions SK TU4-	66
Table 8: external PotentiometerBox SK TU4-POT-	66
Table 9: external modules – maintenance switch SK TU4-MSW-	67
Table 10: Temperature sensors, adjustment.....	79
Table 11: AS-Interface, connection of signal and supply cables	85
Table 12: FAQ operational problems.....	172
Table 13: EMC comparison between EN 61800-3 and EN 55011.....	186
Table 14: Overview according to product standard EN 61800-3	188
Table 15: Overcurrent relative to time	192
Table 16: Overcurrent relative to pulse and output frequency	193
Table 17: Set and actual value processing in the frequency inverter.....	208

1 General

The devices have sensorless current vector control with a wide range of settings. In combination with suitable motor models, which always provide an optimised voltage/frequency ratio, all three-phase asynchronous motors that are suitable for inverter operation and permanently excited synchronous motors can be driven. For the drive, this means very high starting and overload torques at a constant speed.

The power range is from 0.25 kW to 2.2 kW.

The device series can be adapted to individual requirements by means of modular assemblies.

This manual is based on the device software as stated in the version list (see P707). If the frequency inverter uses a different software version, this may cause differences. If necessary, the current manual can be downloaded from the Internet (<http://www.nord.com/>).

Additional descriptions exist for optional functions and bus systems (<http://www.nord.com/>).



Information

Accessories

The accessories that are mentioned in the manual are also subject to changes. Current details of these are included in separate data sheets, which are listed under www.nord.com under the heading *Documentation → Manuals → Electronic drive technology → Techn. info / Data sheet*. The data sheets available at the date of publication of this manual are listed by name in the relevant sections (TI ...).

Installation directly on a motor is typical of this device series. Alternatively, optional accessories are also available for mounting the devices close to the motor, e.g. on the wall or on a machine frame.

In order to have access to all parameters, the internal RS232 interface (access via RJ12 connection) can be used. Access to the parameters takes place via an optional SimpleBox or ParameterBox, for example.

The parameter settings modified by the operator are backed up in the integrated, non-volatile memory of the device.

1.1 Overview

This manual describes the total number of possible functions and features. Depending on the device type, the features and functions are limited.

Basic characteristics

- High starting torque and precise motor speed control by means of sensorless current vector control
- Can be mounted directly on the motor or close to the motor
- Permissible ambient temperature: -25 °C to 50 °C (please refer to technical data)
- Integrated EMC mains filter for limit values of class B / category C1, motor-mounted (not for 115 V devices)
- Automatic measurement of the stator resistance and determination of the exact motor data possible
- Programmable direct current braking
- Size 2 only: Installed brake chopper for 4-quadrant operation, optional braking resistors (internal/external)
- 2 analogue inputs (switchable between current and voltage operation), which can also be used as digital inputs
- 3 digital inputs
- 2 digital outputs
- Separate temperature sensor input (TF+/TF-)

- NORD system bus for connection of additional modules with switchable terminating resistor and address that can be set via DIP switch
- Four separate online switchable parameter sets
- LEDs for diagnosis
- RS232 / RS485 interface via RJ12 plug
- Operation of *three-phase asynchronous motors* (ASM) and NORD IE4 motors (*permanent magnet synchronous motors*= PMSM)
- Integrated PLC ( [BU 0550](#))

SK 190E additional characteristics

- Integrated AS-Interface

Option modules

Option modules are used to extend the functionality of the device.

These options are available as an installation variant, the so-called SK CU4-... customer unit, and also as an attachment variant, the so-called SK TU4-... technology unit. As well as the mechanical differences, the installation and attachment variants also have some functional differences.

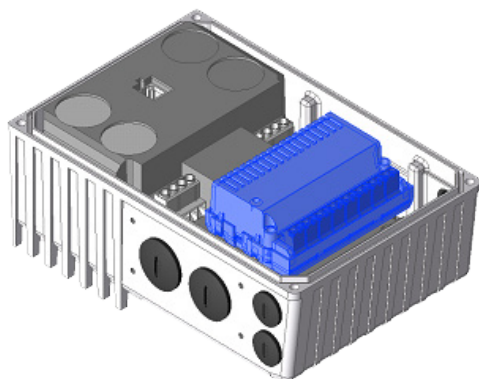

Figure 1: Device with internal SK CU4-...



Figure 2: Device with external SK CU4-...

Attachment variant

The **external technology unit (Technology Unit SK TU4-...)** is externally attached to the device and is therefore easy to access.

A technology unit basically requires the use of a suitable SK TI4-TU-... connection unit.

The power supply and signal lines are connected using the screw clamps of the connection unit. Depending on the version, additional connections for connectors (e.g. M12 or RJ45) may be available.

The optional wall mounting kit SK TIE4-WMK-TU also allows the technology units to be mounted away from the starter.

Built-in variant

The **internal customer unit (Customer Unit, SK CU4-...)** is integrated in the device. The power supply and signal lines are connected using screw clamps.

An exception among the “SK CU4 modules” is the **SK CU4-POT** potentiometer adapter, which is not integrated but mounted to the device.

The communication between “intelligent” optional modules and the device takes place via the system bus. Intelligent optional modules are modules with integrated processor or communication technology as is the case with field bus modules, for example.

The frequency inverter is able to manage the following options via its system bus:

- 1x SK PAR-5H ParameterBox (via RJ12 plug)
- 1x Field bus option (for example Profibus DP), internal or external
- 2x I/O extension (SK xU4-IOE-...), internal and/or external

Up to four frequency inverters with corresponding options can be connected to a system bus.

1.2 Delivery

Examine the device for transport damage or loose components **immediately** on delivery / unpacking.

In case of damage, contact the carrier immediately and arrange for a careful survey.

Important! This also applies if the packaging is undamaged.

1.3 Scope of delivery

NOTICE

Defect in the device

Use of impermissible accessories and options (e.g. also options for other inverter series) may result in defects of interconnected components.

- Only use accessories and options which are explicitly intended for use with this device and stated in this manual.

Standard version:

- Device in IP55 design (optionally IP66)
- Operating instructions as PDF file on CD-ROM including NORDCON (PC parameterisation software)

1.4 Safety, installation and application information

Before working on or with the device, please read the following safety instructions extremely carefully. Please pay attention to all other information from the device manual.

Non-compliance can result in serious or fatal injuries and damage to the device or its surroundings.

These safety instructions must be kept in a safe place!

1. General

Do not use defective devices or devices with defective or damaged housings or missing covers (e.g. blind plugs for cable glands). Otherwise, there is a risk of serious injury or death from electric shock or rupture of electrical components, e.g. high power capacitors.

Unauthorised removal of covers, improper use, incorrect installation or operation causes a risk of serious personal injury or material damage.

Depending on its protection class, the devices may have live, bare, moving or rotating parts or hot surfaces during operation.

The device is operated with hazardous voltage. Dangerous voltage may be present at the supply lines, contact strips and PCBs of all connecting terminals (e.g. mains input, motor connection), even if the device is not working or the motor is not rotating (e.g. caused by electronic disabling, jamming of the drive or a short circuit at the output terminals).

The device is not equipped with a master mains switch and is thus always live when connected to mains voltage. Voltages may therefore be connected to a connected motor at standstill.

A connected motor may also rotate if the drive is disconnected from the mains and possibly generate hazardous voltage.

If persons come into contact with dangerous voltage such as this, there is a risk of an electric shock, which can lead to serious or fatal injuries.

The device and any power plug connectors must not be disconnected while a voltage is applied to the device. Failure to comply with this may cause arcing, which in addition to the risk of injury, also may result in a risk of damage or destruction of the device.

The fact that the status LED or other indicators are not illuminated does not safely indicate that the device has been disconnected from the mains and is without voltage.

The heat sink and all other metal components may heat up to temperatures above 70 °C.

Touching these parts can result in local burns to the body parts concerned (cooling times and clearance from neighbouring components must be complied with).

All work on the device, e.g. transportation, installation, commissioning and maintenance work must be carried out by qualified personnel (observe IEC 364 or CENELEC HD 384 or DIN VDE 0100 and IEC 664 or DIN VDE 0110 and national accident prevention regulations). In particular, the general and regional installation and safety regulations for work on low-voltage systems (e.g. VDE) must be complied with, as must the regulations concerning correct use of tools and the use of personal protection equipment.

During all work on the device, take care that no foreign bodies, loose parts, moisture or dust enter or remain in the device (risk of short circuit, fire and corrosion).

With certain setting conditions, the device or the motor which is connected to it may start automatically when the mains are switched on. The machinery which it drives (press / chain hoist / roller / fan etc.) may then make an unexpected movement. This may cause various injuries, including to third parties.

Before switching on the mains, secure the danger area by warning and removing all persons from the danger area.

Further information can be found in this documentation.

Triggering of a circuit breaker

If the device is secured by a circuit breaker and if this was triggered, this may indicate that a residual current was interrupted. A component (e.g. device, cable or plug connector) in this circuit may have caused an overload (e.g. short circuit or earth fault).

A direct reset of the circuit breaker may lead to the circuit breaker not being triggered afterwards although the fault cause is still present. As a result, any current flowing into the fault location may cause overheating and ignite the surrounding material.

After each triggering of a circuit breaker, all live components within this circuit must thus be visually checked for defects and flashover tracks. Also check the connections at the device's connection terminals.

In case of no faults found or after the replacement of the defect components, switch on the power supply by resetting the circuit breaker. Carefully observe the components keeping a safe physical distance. As soon as you observe a malfunction (e.g. smoke, heat or unusual odours), the occurrence of a new fault or if the status LED on the device does not light up, switch off the circuit breaker immediately and disconnect the defect component from the mains. Replace the defect component.

2. Qualified specialist personnel

Within the meaning of this basic safety information, qualified specialist personnel are persons who are familiar with the installation, assembly, commissioning and operation of the product and who have the qualifications appropriate to their work.

In addition, the device and the accessories associated with it must only be installed and commissioned by a qualified electrician. A qualified electrician is a person who, because of his/her technical training and experience, has sufficient knowledge with regard to

- switching on, switching off, disconnection, earthing and labelling of electric circuits and devices,
- correct maintenance and use of protective devices according to specified safety standards.

3. Intended use – general

Frequency inverters are devices for industrial and commercial systems that are used to operate three-phase asynchronous motors with squirrel-cage rotors. These motors must be suitable for operation on frequency inverters; other loads must not be connected to the devices.

The devices are components intended for installation in electrical systems or machines.

Technical data and details on connection conditions can be found on the rating plate and in the documentation, and must be complied with.

The devices may only be used for safety functions which are described and explicitly approved.

CE-labelled devices meet the requirements of the Low Voltage Directive 2014/35/EU. The harmonised standards stated in the Declaration of Conformity are used for the devices.

a. Supplementation: Intended use within the European Union

When installed in machines, commissioning of the devices (i.e. commencement of intended operation) is prohibited until it has been established that the machine meets the provisions of EC Directive 2006/42/EC (Machinery Directive); EN 60204-1 must also be complied with.

Commissioning (i.e. commencement of intended operation) is only permitted if the EMC Directive 2014/30/EU is complied with.

b. Supplementation: Intended use outside the European Union

The local regulations of the operator at the operating site must be observed for the installation and commissioning of the device (see also "a. Supplementation: Intended use within the European Union").

4. Do not make any modifications.

Unauthorised changes and the use of spare parts and additional equipment not purchased from or recommended by NORD may cause fire, electric shock and injury.

Do not change the original coating / paint or apply additional coatings / paints.

Do not make any structural modifications to the product.

5. Phases of life

Transport, storage

The information in the manual regarding transport, storage and correct handling must be complied with.

The permissible mechanical and climatic ambient conditions (see technical data in the manual for the device) must be complied with.

If necessary, suitable, adequately dimensioned means of transport (e.g. lifting gear, rope guides) must be used.

Installation and assembly

The installation and cooling of the device must be implemented according to the regulations in the corresponding documentation. The permissible mechanical and climatic ambient conditions (see technical data in the manual for the device) must be complied with.

The device must be protected against impermissible loads. In particular, components must not be deformed and/or insulation distances must not be changed. Touching of electronic components and contacts must be avoided.

The device and its optional modules contain electrostatically sensitive components, which can be easily damaged by incorrect handling. Electrical components must not be mechanically damaged or destroyed.

Electrical connection

Ensure that the device and the motor are specified for the correct supply voltage.

Installation, maintenance and repair work must not be carried out unless the device has been disconnected from the voltage and at least 5 minutes have elapsed since the mains was switched off! (Due to charged capacitors, hazardous voltages may be present on the device for up to 5 minutes after being switched off from the mains). Before starting work it is essential to check by measurement that all contacts of the power plug connections or the connection terminals are voltage-free.

The electrical installation must be implemented according to the applicable regulations (e.g. cable cross-section, fuses, earth lead connections). Further instructions can be found in the documentation or manual for the device.

Information regarding EMC-compliant installations such as shielding, earthing, location of filters and routing of cables can be found in the documentation for the devices and in the technical information manual [TI 80-0011](#). This information must always be observed even with devices with a CE label. Compliance with the limit values specified in the EMC regulations is the responsibility of the manufacturer of the system or machine.

In case of a fault, inadequate earthing may result in electric shock, possibly with fatal consequences.

The device may only be operated with effective earth connections which comply with local regulations for large leakage currents (> 3.5 mA). Detailed information regarding connections and operating conditions can be obtained from the technical Information manual [TI 80-0019](#).

Connection of the supply voltage may directly or indirectly set the device into operation. Contact with electrically live components may result in electric shock, possibly with fatal consequences.

All poles of cable connections (e.g. power supply) must always be disconnected.

Setup, troubleshooting and commissioning

When working on live devices, the applicable national accident prevention regulations must be complied with.

Connection of the supply voltage may directly or indirectly set the device into operation. Contact with electrically live components may result in electric shock, possibly with fatal consequences.

The parametrisation and configuration of the devices must be selected so that no hazards can occur.

Operation

Where necessary, systems in which the devices are installed must be equipped with additional monitoring and protective equipment according to the applicable safety requirements (e.g. legislation concerning technical equipment, accident prevention regulations, etc.).

All covers must be kept closed during operation.

Due to its operation, the device produces noises within the audible frequency range. These noises may cause long-term stress, discomfort and fatigue, with negative effects on concentration. The frequency range or the noise can be shifted to a less disturbing or almost inaudible range by adjustment of the pulse frequency. However, this may possibly result in derating (lower power) of the device.

Maintenance, repair and decommissioning

Installation, maintenance and repair work must not be carried out unless the device has been disconnected from the voltage and at least 5 minutes have elapsed since the mains was switched off! (Due to charged capacitors, hazardous voltages may be present on the device for up to 5 minutes after being switched off from the mains). Before starting the work, it is essential to check by measurement that all contacts of the power plug connectors or the connection terminals are voltage-free.

Disposal

The product and its parts and accessories must not be disposed of as domestic waste. At the end of its life, the product must be properly disposed of according to the local regulations for industrial waste. In particular, this product contains integrated semiconductor circuits (PCBs and various electronic components, including high power electrolytic capacitors). In case of incorrect disposal there is a risk of formation of toxic gases, which may cause contamination of the environment and direct or indirect injuries (e.g. chemical burns). In the case of high power electrolytic capacitors, there is also a risk of explosion, with the associated risk of injury.

6. Potentially explosive environment (ATEX, EAC Ex)

In order to operate or carry out installation work in potentially explosive environments (ATEX, EAC Ex), the device must be approved and the relevant requirements and notes from the manual of the device must be complied with.

Failure to comply can result in the ignition of an explosive atmosphere and fatal injuries.





- Only persons who are qualified, i.e. trained and authorised for all assembly, service, commissioning and operation work on association with explosion hazard environments may work with the devices described here (including the motors, geared motors, any accessories and all connection technology).
- Explosive concentrations of dust may cause explosions if ignited by hot or sparking objects. Such explosions may cause serious or fatal injuries to persons or severe material damage.
- The drive must comply with the specifications of "**Planning guideline for the operating and installation instructions B1091**" [B1091-1](#).
- Only original parts which are approved for the device and for operation in an explosion hazard area ATEX Zone 22 3D, EAC Ex must be used.
- **Repairs may only be carried out by Getriebbau NORD GmbH & Co. KG.**

1.5 Warning and hazard information

Under certain circumstances, hazardous situations may occur in association with the frequency inverter. In order to give explicit warning of possibly hazardous situations, clear warning and hazard information can be found on the device and in the relevant documentation.

1.5.1 Warning and hazard information on the product

The following warning and hazard information is used on the product.

Symbol	Supplement to symbol ¹⁾	Meaning
	DANGER Device is live > 5min after removing mains voltage	Danger Electric shock The device contains powerful capacitors. Because of this, there may be a hazardous voltage for more than 5 minutes after disconnection from the mains. Before starting work, check that the device is free of voltage at all power contacts by means of suitable measuring equipment.
		It is essential to read the manual in order to prevent hazards!
		CAUTION Hot surfaces The heat sink and all other metal components as well as the surfaces of plug connectors may heat up to temperatures in excess of 70°C. <ul style="list-style-type: none"> • Danger of injury due to local burns on contact. • Heat damage to adjacent objects Allow sufficient cooling time before starting work on the device. Check the surface temperatures with suitable measuring equipment. Maintain an adequate distance to adjacent components or provide protection against contact.
		NOTICE EDS The device contains electrostatically sensitive components, which can be easily damaged by incorrect handling. Avoid all contact (indirect contact by tools or similar, or direct contact) with PCBs and their components.



1) Texts are written in English.

Table 2: Warning and hazard information on the product

1.5.2 Warning and hazard information in the document

The warning and hazard information in this document are located at the beginning of the section which describes the action which may result in the corresponding hazards.

The warning and hazard information is classified as follows according to the risk and the severity of the resulting injuries.

 DANGER!	Indicates an immediate danger, which may result in death or serious injury.
 WARNING	Indicates a possibly dangerous situation, which may result in death or serious injury.
 CAUTION	Indicates a possibly dangerous situation, which may result in slight or minor injuries.
NOTICE	Indicates a possibly harmful situation, which may cause damage to the product or the environment.

1.6 Standards and approvals

All devices across the entire series comply with the standards and directives listed below.







Approval	Directive	Applied standards	Certificates	Label
CE <i>(European Union)</i>	Low Voltage 2014/35/EU	EN 61800-5-1 EN 60529 EN 61800-3 EN 63000 EN 61800-9-1 EN 61800-9-2	C310400, C310401	
	EMC 2014/30/EU			
	RoHS 2011/65/EU			
	Delegated Directive (EU) 2015/863			
	Ecodesign 2009/125/EC			
	EU Ecodesign Directive 2019/1781			
UL <i>(USA)</i>		UL 508C	E171342	
CSA <i>(Canada)</i>		C22.2 No.274-13	E171342	
RCM <i>(Australia)</i>	F2018L00028	EN 61800-3	133520966	
EAC <i>(Eurasia)</i>	TR CU 004/2011, TR CU 020/2011	IEC 61800-5-1 IEC 61800-3	EAЭC N RU Д- DE.HB27.B.0273 0/20	
UkrSEPRO <i>(Ukraine)</i>		EN 61800-5-1 EN 60529 EN 61800-3 EN 63000 EN 60947-1 EN 60947-4 EN 61558-1 EN 50581	C311900	
UKCA <i>(United Kingdom)</i>		EN 61800-5-1 EN 60529 EN 61800-3 EN 63000 EN 61800-9-1 EN 61800-9-2	C350400, C350401	

Table 3: Standards and approvals

Devices which are configured and approved for use in explosion hazard environments ( Section 2.5 "Operation in potentially explosive environments ") comply with the following directives and standards.

Approval	Directive	Applied standards	Certificates	Labels
ATEX (European Union)	ATEX 2014/34/EU	EN 60079-0	C432410	
	EMC 2014/30/EU	EN 60079-31		
	RoHS 2011/65/EU	EN 61800-5-1		
	Ecodesign 2009/125/EC	EN 60529		
	EU Ecodesign Regulation 2019/1781	EN 61800-3		
		EN 63000		
		EN 61800-9-1		
		EN 61800-9-2		

Table 4: Standards and approvals for explosion hazard environments

1.6.1 UL and CSA approval

File No. E171342

The categorisation of protective equipment approved by the UL according to United States standards for the devices described in this manual is listed below, basically with the original wording. The categorisation of the individually relevant fuses or circuit breakers can be found in the “Electrical Data” section of this manual.

All devices include motor protection.

7.3 "Electrical data"

i Information

Group fuse protection

The devices can be protected as a group via one common fuse (see below for details). Pay attention to compliance with the total currents and the use of correct cables and cable cross-sections. If the device is mounted close to the motor, this also applies to the motor cables.

Conditions UL/CSA according to report

i Information

"Integral solid state short circuit protection does not provide branch circuit protection. Branch circuit protection must be provided in accordance with the National Electric Code and any additional local codes."

"Use 60/75°C copper field wiring conductors."

„These products are intended for use in a pollution degree 2 environment“

"The device has to be mounted according to the manufacturer instructions."

"For NFPA79 applications only"

i Information

Internal Break Resistors (PTCs)

Alternate - internal brake resistors, optional for drives marked for USL only (not for Canada), Unlisted Component NMTR3, manufactured by Getriebebau:

	Usage	Cat. No.
1	750-323, 111-323	BRK-100R0-10-L
2	FS2	BRK-200R0-10-L

Size	valid	description
1 - 2	generally valid	<p>“Suitable For Use On A Circuit Capable Of Delivering Not More Than 100 000 rms Symmetrical Amperes, 480 Volts Maximum” and minimum one of the two following alternatives.</p> <p>When used together with or without Accessory SK TU4-MSW: “Suitable For Use On A Circuit Capable Of Delivering Not More Than 10 000 rms Symmetrical Amperes, 480 Volts Maximum” and minimum one of the two following alternatives.</p> <p>1. “When Protected by class RK5 Fuses or faster or when protected by High-Interrupting Capacity, Current Limiting Class CC, G, J, L, R, T, etc. Fuses, rated _____ Amperes, and _____ Volts”, as listed in ¹⁾.</p> <p>2. “Suitable For Use On A Circuit Capable Of Delivering Not More Than 65 000 rms Symmetrical Amperes, _____ Volt maximum”, “When Protected by Circuit Breaker (inverse time trip type) in accordance with UL 489, rated _____ Amperes, and _____ Volts”, as listed in ¹⁾.</p>
	Motor group installation (Group fusing):	<p>“Suitable for motor group installation on a circuit capable of delivering not more than 100 000 rms symmetrical amperes, 480 V max” “When Protected by class RK5 Fuses or faster, rated 30_Amperes”</p> <p>“Suitable for motor group installation on a circuit capable of delivering not more than 100 000 rms symmetrical amperes, 480 V max” “When Protected by High-Interrupting Capacity, Current Limiting Class CC, G, J, L, R, T, etc. Fuses rated 30 Amperes”</p> <p>“Suitable for motor group installation on a circuit capable of delivering not more than 65 000 rms symmetrical amperes, 480 V max” “When Protected by Circuit Breaker (inverse time trip type) in accordance with UL 489, rated 30 Amperes and 480 Volts min”</p>
	differing data CSA:	None differing data → equal to UL

1) (EN 7.3)

1.7 Type code / nomenclature

Unique type codes have been defined for the individual modules and devices. These provide individual details of the device type and its electrical data, protection class, fixing version and special versions. A differentiation is made according to the following groups:

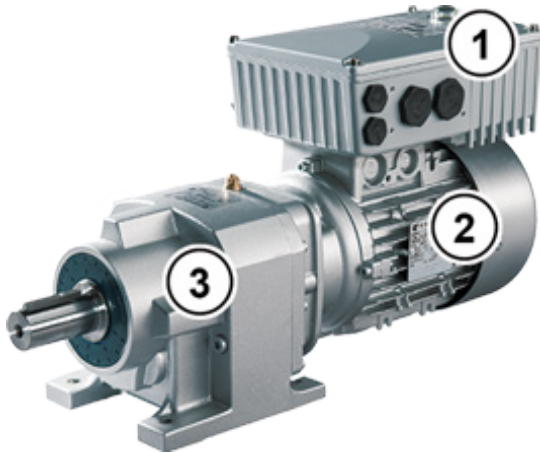

1	Frequency inverter
2	Motor
3	Gear units

5	Optional module
6	Connection unit
7	Wall-mounting kit

1.7.1 Name plate

All of the information which is relevant for the device, including information for the identification of the device, can be obtained from the name plate.



Legend

Type:	Type / designation
Part-No:	Part number
ID:	Device identification number

FW:	Firmware status (x.x Rx)
HW:	Hardware status (xxx)
Input:	Mains voltage
Input Current:	Input current
Output:	Output voltage
Output Current:	Output current
Output Power:	Output power
Protection:	Protection class
Temp. Range	Temperature range
Dissipation:	Energy efficiency

Figure 3: Name plate

1.7.2 Frequency inverter type code

SK 180E-370-323-B (-C) (-xxx)

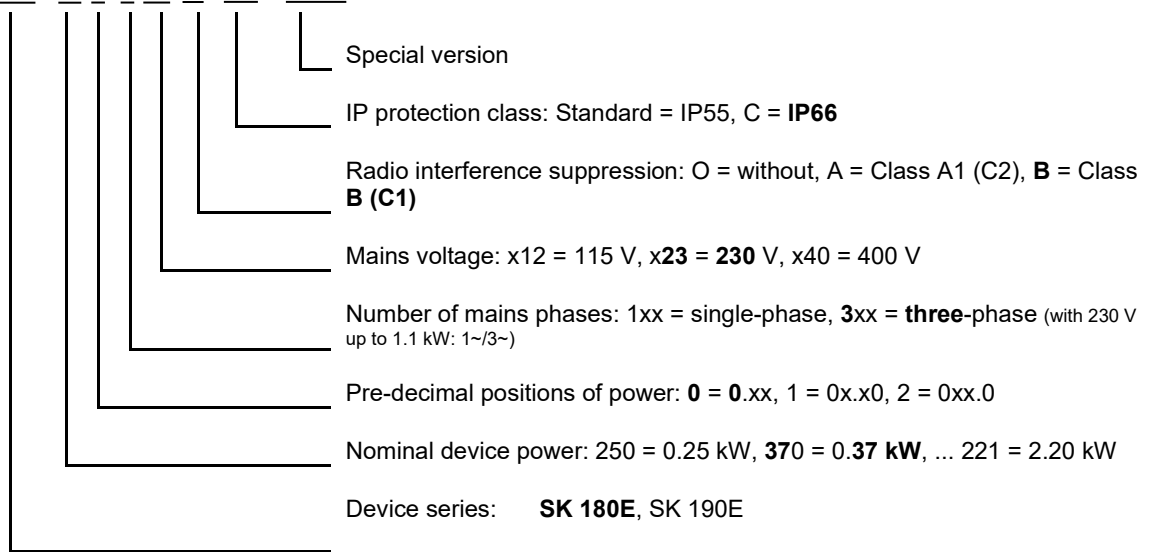

(...) Options, only listed if required.

1.7.3 Type code for option modules

For bus module or I/O extension

SK TU4-CAO (-C-M12)

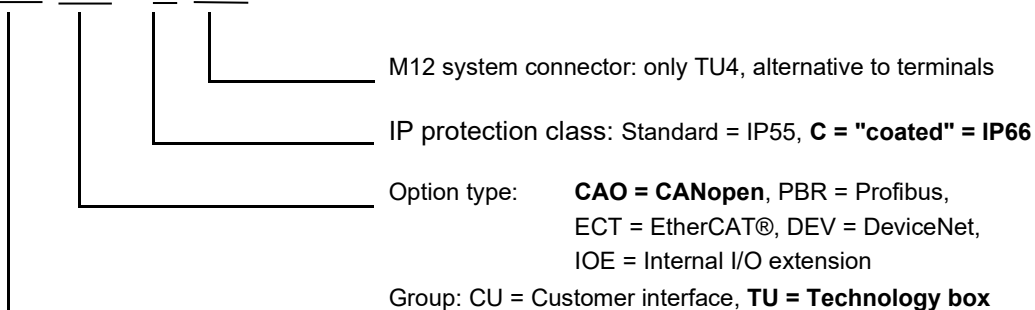

(...) Options, only implemented if required.

1.7.4 Type code, connection unit for technology unit

SK TI4-TU-BUS (-C)

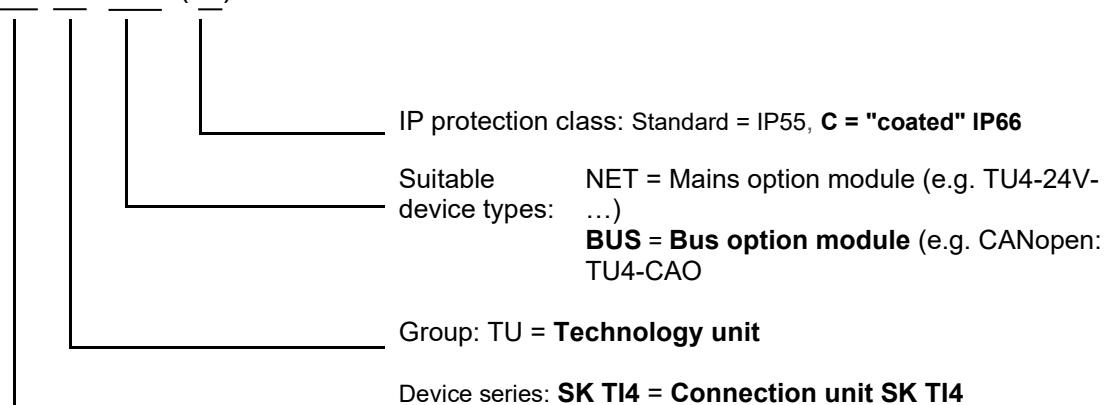

(...) Options, only implemented if required.

1.7.5 Adapter Unit type code

SK TIE4-WMK-1 (-C- ...)

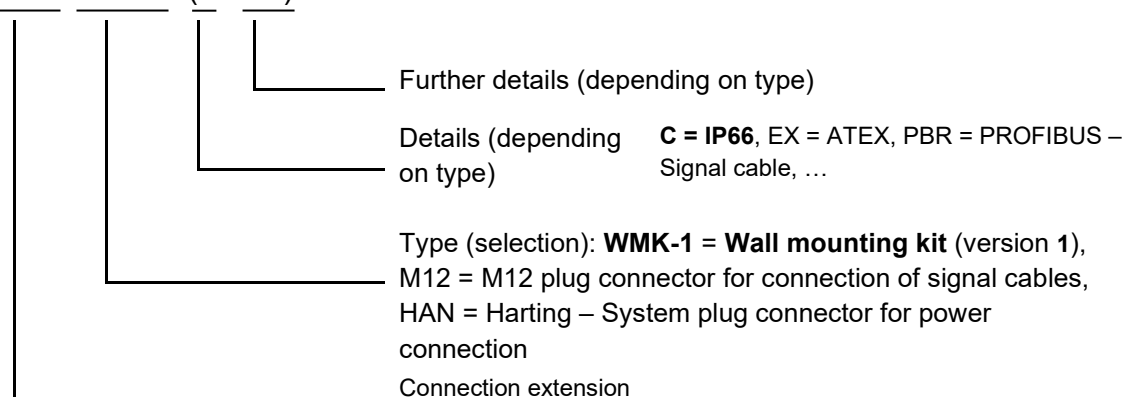

1.8 Power rating / Motor size

Size	Mains / output assignment			
	1~ 110 - 120 V	1~/ 3~ 200 – 240 V	3~ 200 – 240 V	3~ 380 – 480 V
Size 1	0.25 ... 0.75 kW	0.25 ... 0.55 kW	-	0.25 ... 1.1 kW
Size 2	-	0.75 ... 1.1 kW	1.5 kW	1.5 ... 2.2 kW

1.9 Version in protection class IP55, IP66

The SK 1x0E is available in IP55 (standard) or IP66 (optional). The additional modules are available in protection classes IP55 (standard) or IP66 (optional).

A protection class that differs from the standard (IP66) must always be specified in the order when ordering!

There are no restrictions or differences to the scope of functionality in the protection classes that have been mentioned. The type designation is extended accordingly in order to distinguish between the protection classes.

e.g. SK 1x0E-221-340-A-C



Information

Cable laying

For all versions, care must be taken that the cables and the cable glands at least comply with the protection class of the device and the attachment regulations and are carefully matched. The cables must be inserted so that water is deflected away from the device (if necessary use loops). This is essential to ensure that the required protection class is maintained.

IP55 version:

The IP55 version is the **standard** version. In this version, the two installation types *motor mounted* (fitted onto the motor) and *close coupled* (fitted to the wall bracket) are available. All adapter units, technology units and customer units are also available for this version.

IP66 version:

The IP66 version is a modified **option** of the IP55 version. Both installation types (*motor-integrated*, *close coupled*) are also available for this version. The modules available to the IP66 design (adapter units, technology units and customer units) have the same functionalities as the corresponding IP55 design modules.



Information

IP66 special measures

IP66 modules have an additional “-C” in their type code and are modified with the following special measures:

- Impregnated PCBs
 - RAL 9006 (white aluminium) powder coating for housings
 - Modified blind plugs (UV-resistant)
-

2 Assembly and installation

2.1 Installation SK 1x0E

The devices are available in various sizes depending on their output. They can be mounted on the terminal box of a motor or in its immediate vicinity.

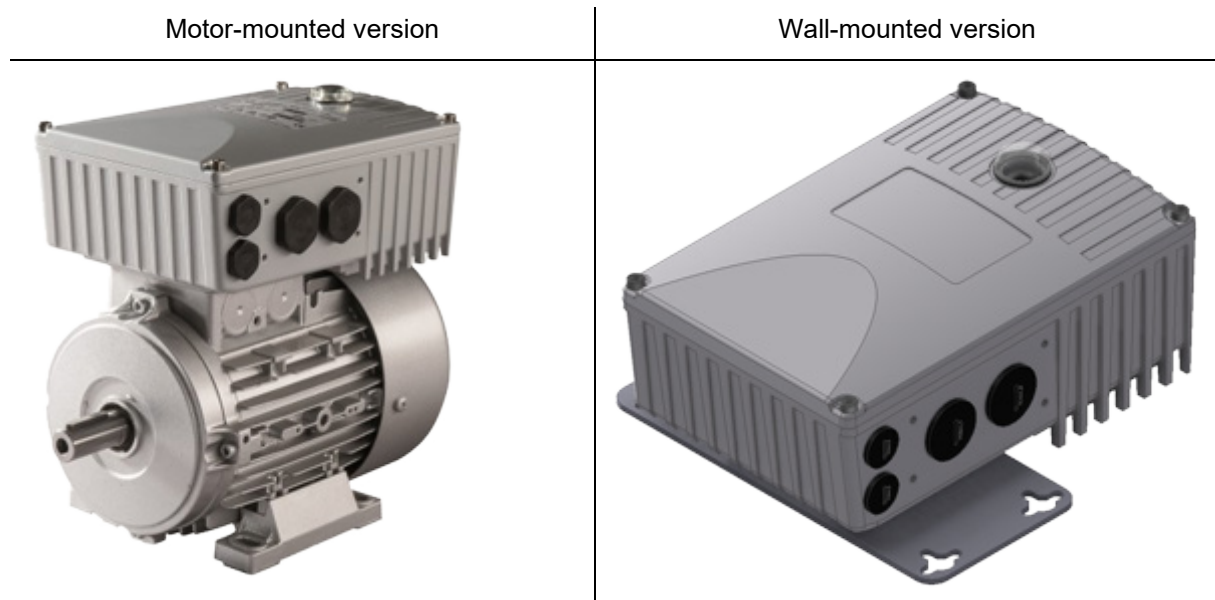

When a complete drive unit (gear unit + motor + SK 1x0E) is delivered, the device is always fully installed and tested.

i Information

Device version IP6x

IP6x-compliant devices must be installed by NORD, since special measures have to be implemented. IP6x components that are retrofitted on site cannot ensure that this protection class is provided.

When delivered separately, the device includes the following components:

- SK 1x0E
- Screws and contact washers for mounting the motor terminal box
- Pre-fabricated cable for motor and PTC connections

i Information

Power derating

The equipment requires **sufficient ventilation** to protect against overheating. If this cannot be guaranteed, this results in power reduction (derating) of the frequency inverter. The ventilation is influenced by the type of installation (motor-mounting, wall-mounting) and/or with motor-mounting: the air flow of the motor fan (continuous slow speed → lack of cooling).

Insufficient cooling can result in power reduction of 1 - 2 power stages during S1 operation, for example, which can only be compensated for by using a nominally bigger device.

Details concerning output reduction and possible ambient temperatures, and other details (📖 Section 7 "Technical data").

2.1.1 Work procedures for motor installation

1. If necessary, remove the original terminal box from the NORD motor, so that only the base of the terminal box and the motor terminal strip remain.
2. Set the bridges for the correct motor circuit at the motor terminal strip, and connect the pre-fabricated cables for motor and PTC connections to the respective connection points on the motor.
3. Remove the casing cover from the SK 1x0E. To do this, undo 4 fastening screws and then remove the casing cover vertically from above.



4. Fit the casing of the SK 1x0E to the terminal box base of the NORD motor using the existing screws and seal as well as the provided toothed contact washers. When doing this, align the casing so that the rounded side is facing the direction of the A bearing cover of the motor. Carry out mechanical adaptation using the "Adapter kit" (see Section 2.1.1.1 "Adapters for different motors"). With motors made by other manufacturers, it must be checked whether they can be attached.

If necessary, the plastic cover (1) for the electronics must be carefully removed in order to make the screw fastenings to the base of the terminal box. Proceed with extreme caution when doing this to avoid damage to the exposed PCBs.

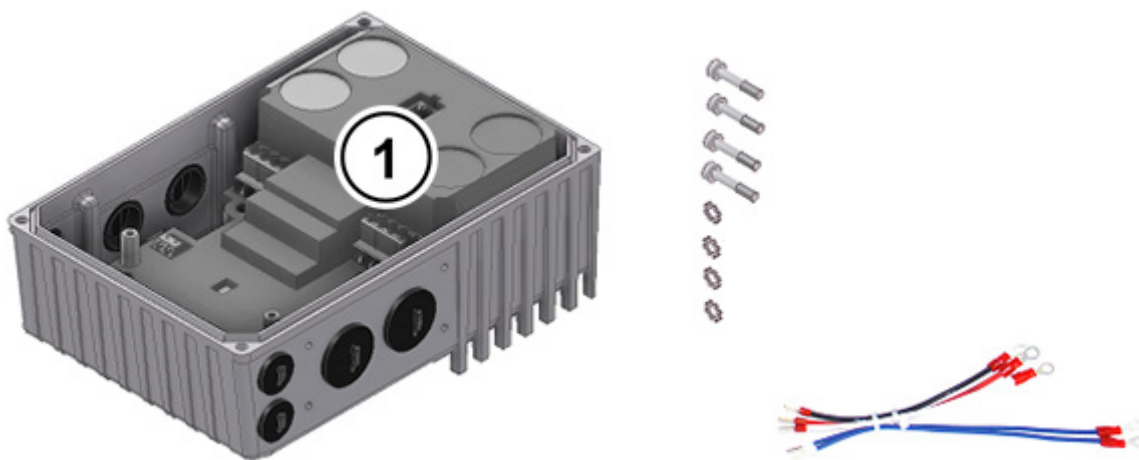

5. Make electrical connections. For the cable gland of the connecting cable, appropriate screwed connections for cable cross-section must be used.
6. Re-attach the casing cover. In order to ensure that the protection class for the device is achieved, care must be taken that all the fastening screws of the housing cover are tightened crosswise, gradually and with the torque specified in the table below.

The cable glands that are used must at least correspond to the protection class of the device.

Size SK 1x0E	Screw size	Tightening torque
Size 1	M5 x 25	3.5 Nm ± 20 %
Size 2	M5 x 25	3.5 Nm ± 20 %

2.1.1.1 Adapters for different motors

In some cases, the terminal box attachments are different for different motor sizes. Therefore, it may be necessary to use adapters to mount the device.

In order to ensure that the maximum IPxx protection class of the device is provided for the entire unit, all elements of the drive unit (e.g. motor) must correspond to at least the same protection class.

i Information

External motors

The adaptability of motors from other manufacturers must be checked individually!

Information about converting a drive to the device can be found in [BU0320](#).

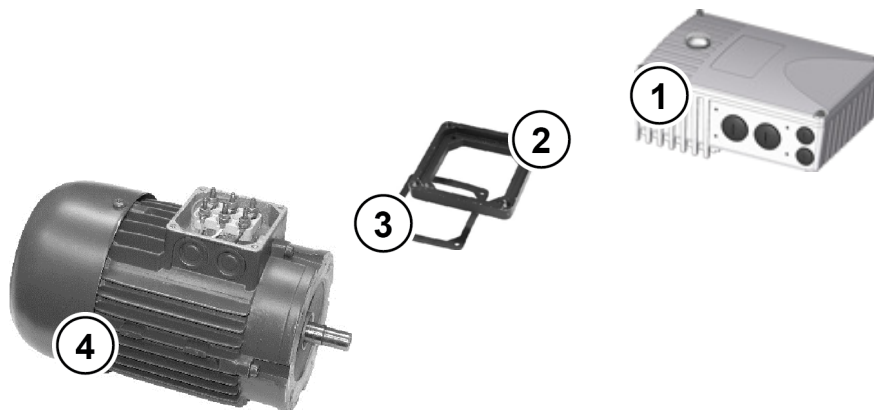

- 1 SK 1x0E
- 2 Adapter plate
- 3 Gasket
- 4 Motor, size 71

Figure 4: Example of motor size adaptation

NORD motor size	Attachment SK 1x0E size 1	Add-on SK 1x0E size 2
Size 63 – 71	with adapter kit I	with adapter kit I
Size 80 – 100	<i>Direct mounting</i>	<i>Direct mounting</i>

Overview of adapter kits

Adapter kit		Name	Components	Part No.
Adapter kit I	IP55	SK T14-12-Adapter kit_63-71	Adapter plate, terminal box frame seal and screws	275119050
	IP66	SK T14-12-Adapter kit_63-71-C		275274324

2.1.1.2 Dimensions, SK 1x0E mounted on motor

Size		Housing dimensions SK 1x0E / Motor					Weight of SK 1x0E without motor approx. [kg]
FI	Motors	Ø g	g 1	n	o	p	
Size 1	Size 63 ¹⁾	130	177.0	221	192	154	2.9
	Size 71 ¹⁾	145	177.5		214		
	Size 80	165	171.5		236		
	Size 90 S / L	183	176.5		251 / 276		
Size 2	Size 80	165	196.5	255	236	165	4.1
	Size 90 S / L	183	201.5		251 / 276		
	Size 100	201	210.5		306		

All dimensions in [mm]
¹⁾ including additional adapter and seal (18 mm) [275119050]

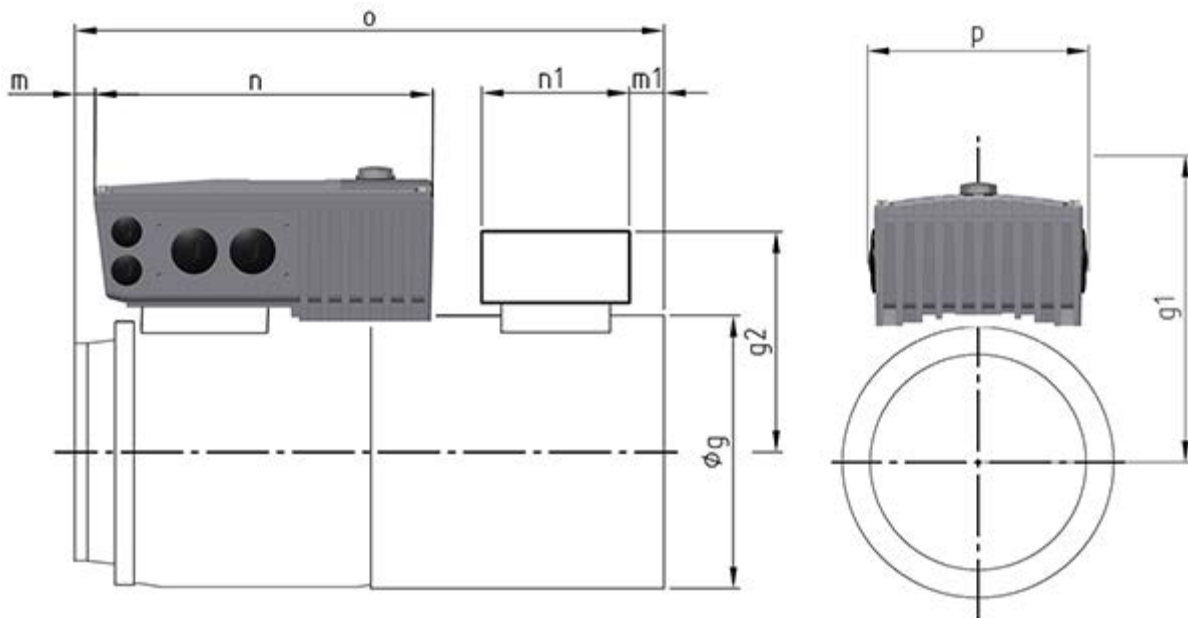

2.1.2 Wall mounting

As an alternative to wall mounting, the device can also be installed close to the motor using an optional wall-mounting kit.

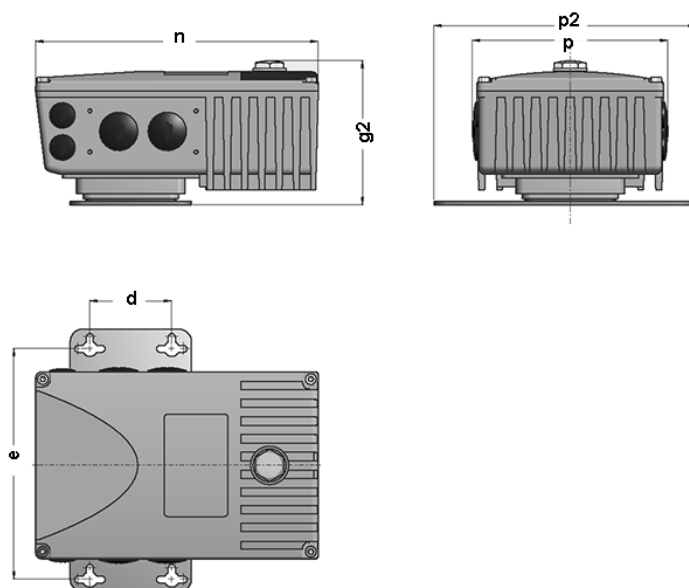

Wall-mounting kit SK TI4-WMK-... (...1-K)

This wall-mounting kit provides a simple method for installing the device close to the motor.

The SK TIE4-WMK-1-K version is made of plastic. It is equally suitable for IP55 and IP66 devices.

All mounting positions are permissible for wall mounting, taking into account the electrical data.

Device size	Wall-mounting kit	Housing dimensions				Mounting dimensions			Total weight Approx. [kg]
		g2	n	p	p2	d	e	Ø	
Size 1	SK TIE4-WMK-1-K Part no. 275 274 004	113	221	154	205	64	180	5.5	2.2
Size 2	SK TIE4-WMK-1-K Part no. 275 274 004	136	254	165	205				3.5
All dimensions in [mm]									

Wall mounting kit SK TIE4-WMK-1-EX

This wall mounting kit is intended for use in explosion hazard environments (see Section 2.5 "Operation in potentially explosive environments"). It is made of stainless steel and is equally suitable for IP55 and IP66 devices

Size of device	Wall mounting kit	Housing dimensions				Mounting dimensions			Total Weight Approx. [kg]
		g2	n	p	p2	d	e	Ø	
Size 1	SK TIE4-WMK-1-EX Part. No. 275 175 053	113	221	154	205	64	180	5.5	2.6
Size 2	SK TIE4-WMK-1-EX Part. No. 275 175 053	136	254	165	205				3.9
All dimensions in [mm]									

2.2 Installation of optional modules

Modules must not be inserted or removed unless the device is free of voltage. The slots may only be used for the intended modules.

2.2.1 Option locations on device

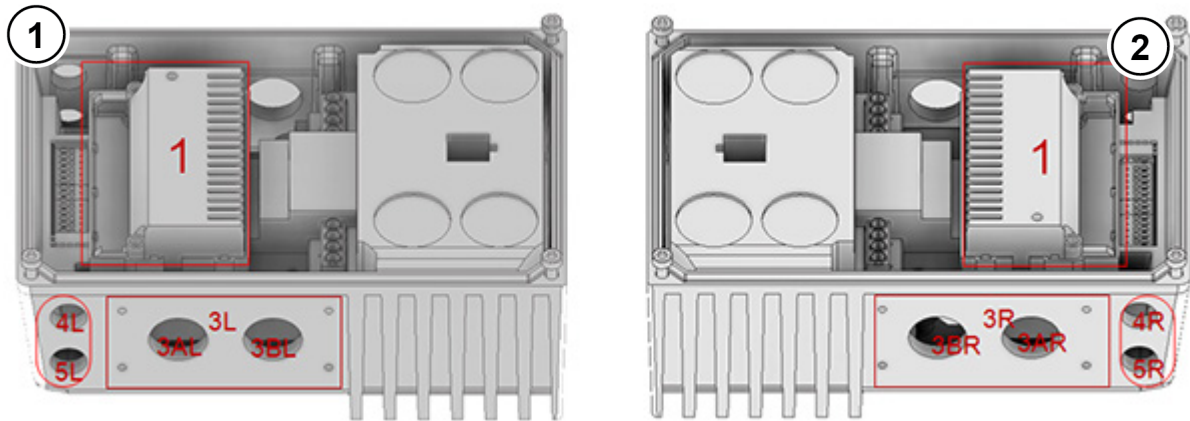

Figure 5: Option locations, size 1

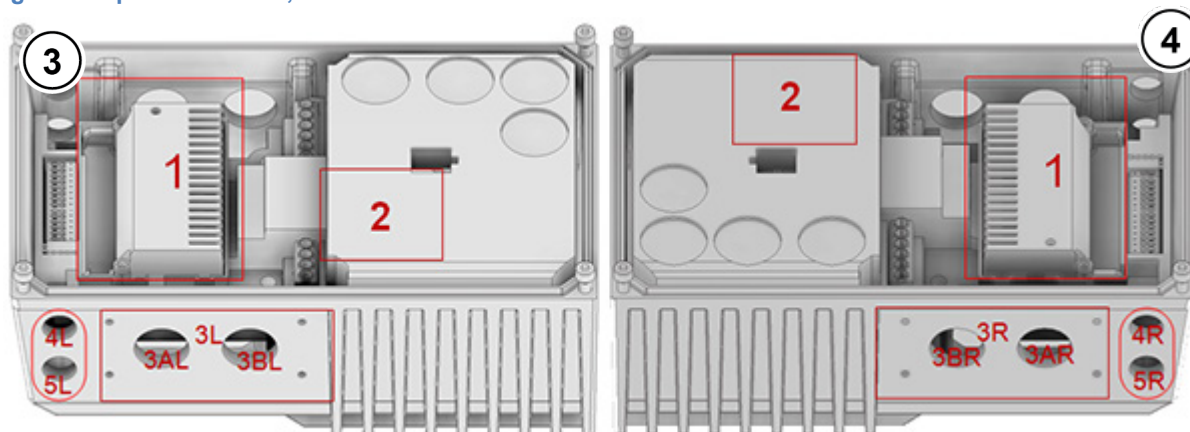
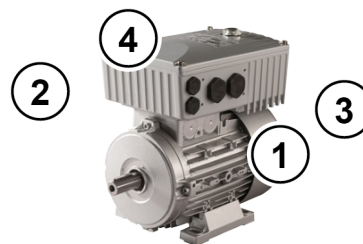

Figure 6: Option locations, size 2

- 1 View from left, size 1
- 2 View from right, size 1
- 3 View from left, size 2
- 4 View from right, size 2



The various installation locations for the optional modules are drawn into the drawings shown above. Option location 1 is used to install an internal bus module.

An internal braking resistor can be installed in mounting location 2 (only available in size 2). **The braking resistor cannot be retrofitted and must therefore be taken into account in the order.**

External bus modules or 24 V power supplies can be implemented at option location 3L or 3R. The same applies to external braking resistors. Option locations 4 and 5 are used to install M12 sockets or connectors or also for cable glands. Only one option can be attached in an option location, of course.

2 Assembly and installation

Option location	Position	Meaning	Size	Comments
1	Internal	Mounting location for customer units SK CU4-...		
2	Internal	Mounting location for internal braking resistor		Only for size 2
3*	on side	Mounting location for <ul style="list-style-type: none"> • External technology box SK TU4-... • External braking resistor SK BRE4-... • Power connector 		
3 A/B*	on side	Cable gland	M25	Not available if location 3 is occupied or SK TU4-... is fitted.
4* 5*	on side	Cable gland	M16	Not available if SK TU4-... is fitted.
* R and L (right and left side) – with engine installation: Viewing direction from impeller to motor shaft				

2.2.2 Installation of internal customer unit SK CU4-... (installation)



Information

Installation location of customer unit

Installation of the SK CU4-... customer unit **separately** from the device is not permitted. It must always be installed inside the device in the intended position (option location 1). Only one customer unit can be installed per device!

Prefabricated cables are provided with the customer unit.

Connections are made according to the following table:



Similar to illustration

Bag enclosed with internal customer unit

Allocation of the cable sets (accessories supplied with customer unit)

	Function	Terminal label	Cable colour	
	Voltage supply (24V DC) (between device and customer unit)	44	24V	brown
		40	GND/0V	blue
	System bus	77	SYS H (+)	black
		78	SYS L (-)	grey

The bus modules require a 24V supply voltage.

The customer units are installed inside the housing box of the device.

The customer unit is secured with two screws provided.

Only one customer unit per device is possible!

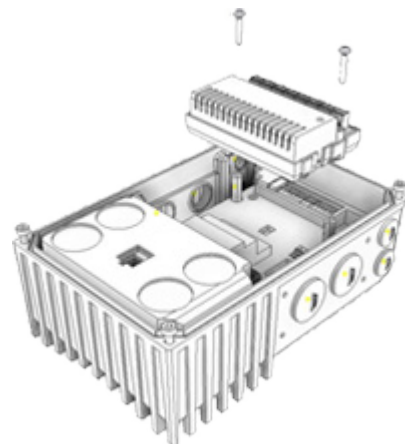

2.2.3 Installation of external technology units SK TU4-... (attachment)

The technology units SK TU4-...(-C) require a connection unit SK TI4-TU-...(-C). This is the only way to create a closed functional unit. This can be attached to the device or installed separately by means of the optional SK TIE4-WMK-TU wall-mounting kit. In order to provide reliable operation, cable lengths of more than 20 m between the technology unit and the device must be avoided.



Information

Detailed installation information

A detailed description can be found in the documents for the connection unit concerned.

Connection unit	Document
SK TI4-TU-BUS	TI 275280000
SK TI4-TU-BUS-C	TI 275280500
SK TI4-TU-NET	TI 275280100
SK TI4-TU-NET-C	TI 275280600
SK TI4-TU-MSW	TI 275280200
SK TI4-TU-MSW-C	TI 275280700

2.3 Braking resistor (BW) - (from size 2)

During dynamic braking (frequency reduction) of a three-phase motor, electrical energy is returned to the inverter if necessary. **From size 2 and above**, an internal or external braking resistor can be used to avoid a shut-down of the device due to overvoltage. With this, the integrated brake chopper (electronic switch) pulses the link circuit voltage (switching threshold approx. 420 V / 720 V_{DC}, depending on mains voltage) into the braking resistor. The braking resistor converts excess energy into heat.

CAUTION

Hot surfaces

The braking resistor and all other metal components may heat up to temperatures above 70 °C. If touched, there is a risk of injury from local burns. Adjacent objects may be damaged by heat.

- Allow sufficient cooling time before starting work on the product
- Check surface temperature by means of suitable measuring equipment
- Maintain an adequate distance to adjacent components

2.3.1 Internal braking resistor SK BRI4-...

The internal braking resistor can be used if only slight, short braking phases are to be expected.

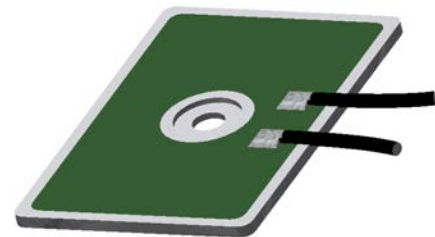

Similar to illustration

- The braking resistor **cannot be retrofitted** and must therefore be taken into account in the order.
- The output power of the braking resistor is limited and can be calculated as follows.

$$P = P_n * (1 + \sqrt{(30 / t_{brake})})^2, \text{ however, the following applies } P < P_{max}$$

- (P=Brake power (W), P_n= Continuous brake power of resistor (W), P_{max}. peak brake power, t_{brake} = duration of braking process (s))
- (For details of P_n and P_{max} see  Section 0 "Electrical data")
- The permissible continuous brake power P_n must not be exceeded in the long-term average.
- The peak and continuous powers must be limited by adjusting the parameter settings.

Required parameter settings

Certain device versions feature a factory-fitted braking resistor. In delivery state, the relevant peak load and continuous power limit parameters are preset (refer to the following tables).

NOTICE

Damage due to incorrect parameterisation

Incorrect setting values for parameters **P555**, **P556** and **P557** impair the correct functioning of the braking resistor and may destroy it and the frequency inverter.

- After using the "Factory setting" (**P523**) parameter with either function 1, 2 or 3, it is essential to reset parameters **P555**, **P556** and **P557** to the correct values.

SK 1x0E-750-323-B(-C)-BRI SK 1x0E-111-323-B(-C)-BRI SK 1x0E-151-323-B(-C)-BRI			
Parameter number	Meaning	Setting [Unit]	Remarks
P555	P-limit chopper	100 [%]	Power limit ¹⁾
P556	Braking resistor	200 [Ω]	Electrical resistance ¹⁾
P557	Brake resistor type	0.05 [kW]	Maximum continuous power P_n ¹⁾

1) Of the braking resistor

SK 1x0E-151-340-B(-C)-BRI SK 1x0E-221-340-B(-C)-BRI			
Parameter number	Meaning	Setting [Unit]	Remarks
P555	P-limit chopper	65 [%]	Power limit ¹⁾
P556	Braking resistor	400 [Ω]	Electrical resistance ¹⁾
P557	Brake resistor type	0.05 [kW]	Maximum continuous power P_n ¹⁾

1) Of the braking resistor

Electrical data

Designation	Electrical resistance	Max. continuous output / limit ²⁾ (P_n)	Power consumption ¹⁾ (P_{max})
SK BRI4-1-200-100 ³⁾	200 Ω	100 W / 25 %	1.0 kW
SK BRI4-1-400-100 ⁴⁾	400 Ω	100 W / 25 %	1.0 kW
	1) Maximum once within 10 s ²⁾ 2) In order to prevent impermissible heating of the frequency inverter, the continuous power is limited to 1/4 of the rated power of the braking resistor. This also has a limiting effect on the energy consumption. 3) Only for Size 2 devices with a rated voltage of 230 V. 4) Only for Size 2 devices with a rated voltage of 400 V.		

2.3.2 External braking resistor SK BRE4-... / SK BRW4-... / SK BREW4-...

The external braking resistor is provided for energy feedback, e.g. as occurs in pulsed drive units or lifting gear. Here, it may be necessary to plan for the exact braking resistor that is required (see adjacent figure).

Installation of an SK BRE4-... is not possible in combination with the wall-mounting kit **SK TIE4-WMK...**. In this case, braking resistors of type **SK BREW4-...** are available as an alternative, which can also be fitted to the frequency inverter.



In addition **SK BRW4-...** type brake resistors are available for mounting on a wall near to the device.

Electrical data

Designation ¹⁾ (IP67)	Resistance	Max. continuous power (P _n)	Energy consumption ²⁾ (P _{max})
SK BRx4-1-100-100	100 Ω	100 W	2.2 kW
SK BRx4-1-200-100	200 Ω	100 W	2.2 kW
SK BRx4-1-400-100	400 Ω	100 W	2.2 kW
SK BRx4-2-100-200	100 Ω	200 W	4.4 kW
SK BRx4-2-200-200	200 Ω	200 W	4.4 kW
	1) SK BRx4-: versions: SK BRE4-, SK BRW4-, SK BREW4- 2) Maximum once within 120s		

i Information
Braking resistor

If required, other versions or installation variants for external braking resistors can be provided.

Braking resistor assignments

The braking resistors provided by NORD are directly tailored to the individual devices. However, when external braking resistors are being used, it is usually possible to select between 2 or 3 alternatives.

Note: The internal braking resistor (SK BRI4-) cannot be retrofitted! The resistor must be taken into consideration when ordering the frequency inverter. In this case, the frequency inverter is given a separate material number and marking **-BRI** at the end of the type key (for example **SK 180E-151-340-B-C-BRI**).

Device SK 1x0E-...	Internal braking resistor	External		
		Preferred braking resistor	alternative braking resistor	Alternative braking resistor
750-323-A	SK BRI4-1-200-100	SK BRx4-1-100-100	SK BRx4-2-200-200	SK BRx4-2-100-200
111-323-A	SK BRI4-1-200-100	SK BRx4-1-100-100	SK BRx4-2-200-200	SK BRx4-2-100-200
151-323-A	SK BRI4-1-200-100	SK BRx4-1-100-100	SK BRx4-2-200-200	SK BRx4-2-100-200
151-340-A	SK BRI4-1-400-100	SK BRx4-1-200-100	SK BRx4-2-400-200	SK BRx4-2-200-200
221-340-A	SK BRI4-1-400-100	SK BRx4-1-200-100	SK BRx4-2-400-200	SK BRx4-2-200-200

1) SK BRx4-: versions: SK BRE4-, SK BRW4-, SK BREW4-

Table 5: Assignment of braking resistors to frequency inverter

2.4 Electrical Connection

WARNING

Electric shock

Dangerous voltage can be present at the mains input and the motor connection terminals, even when the device is not in operation.

- Before starting work, use suitable measuring equipment to check that all relevant components (voltage source, connecting cables, connection terminals of the device) are free of voltage
- Use insulated tools (e.g. screwdrivers)
- Earth devices

WARNING

Hazardous voltage at the TF+, TF-, U, V and W contacts

Touching the contacts may lead to an electric shock.

- If the TF+ and TF- contacts are not used, the open wire ends must be insulated.

NOTICE

Device failure due to increased input current

If 1-phase and 3-phase frequency inverters are operated on the same circuit, this can lead to increased input currents and corresponding faults on the 1-phase devices. You can prevent this effect through

- long mains supply cables (at least 10 m) or
- use of a mains choke before the 1-phase device.

Information

Temperature sensor and PTC resistor (TF)

As with other signal cables, PTC resistor cables must be laid separately from the motor cables. Otherwise, the interfering signals from the motor winding that are induced into the line affect the device.

Ensure that the device and the motor are specified for the correct supply voltage.

Observe the notes on long-term storage in Chapter 9.1 "Maintenance information

".

The housing cover must be removed from the device in order to make the electrical connection ( Section 2.1.1 "Work procedures for motor installation").

One terminal level is provided for the power connections and one for the control connections.

The PE connections (device earth) are located on the power connections for the motor and the mains, as well as on the base inside the cast housing.

The terminal strip assignments differ according to the version of the device. The correct assignment can be found on the inscription on the respective terminal or the terminal overview plan printed inside the device.

	Connecting terminals for
(1)	Power cable (X1.1)
(2)	Motor cable (X2.1)
(3)	Braking resistor lines (size 2 only)
(4)	Control lines (X4)
(5)	Control lines (X5) (SK 190E only)
(6)	PTC thermistor (TF) from motor (X3)
(7)	PE (X1.2 or X2.2)

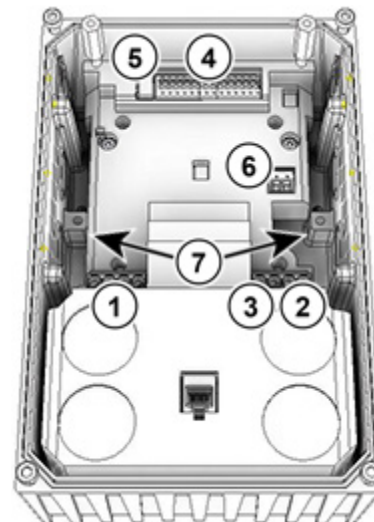

2.4.1 Wiring guidelines

The devices have been developed for use in an industrial environment. In this environment, electromagnetic interference can affect the device. In general, correct installation ensures safe and problem-free operation. To meet the limiting values of the EMC directives, the following instructions should be complied with.

1. Ensure that all devices are securely earthed to a common earthing point or earthing rail using short earthing cables with a large cross-section. It is especially important that each control unit which is connected to the electronic drive technology (e.g. an automatic device) has a short cable with a large cross-section, which is connected to the same earthing point as the device itself. Flat cables (e.g. metal clamps) are preferable, as they have a lower impedance at high frequencies.
2. The bonding cable of the motor controlled by the soft starter should be connected directly to the earthing terminal of the associated device. The presence of a central earthing bar in the control cabinet and the grouping together of all bonding conductors to this bar normally ensures safe operation.
3. Where possible, shielded cables should be used for control circuits. The shielding at the cable end should be carefully sealed and it must be ensured that the wires are not laid over longer distances without shielding.

The shielding of analogue setpoint cables should only be earthed on one side on the device.

4. Control cables should be installed as far as possible from power cables, using separate cable ducts, etc. Where cables cross, an angle of 90° should be ensured as far as possible.
5. Ensure that the contactors in the cabinet are interference protected, either by RC circuits in the case of AC contactors or by free-wheeling diodes for DC contactors, for which **the interference suppressors must be positioned on the contactor coils**. Varistors for over-voltage limitation are also effective.
6. Shielded or armoured cables should be used for the load connections (motor cable if necessary). The shielding or armouring must be earthed at both ends. The earthing should be provided directly to the PE of the device if possible.

Furthermore, attention must be paid to the EMC-compliant wiring.

During the installation of the devices, the safety requirements must not be violated under any circumstances!

NOTICE!

Damage due to high voltage

The device may be damaged by electrical loads which do not correspond to its specification.

- Do not perform any high voltage tests on the device itself.
- Disconnect the cable which is to be tested from the device before performing a high voltage insulation test.

Information

Looping of the mains voltage

The permissible current load for the connection terminals, plugs and supply cables must be observed when looping the mains voltage. Failure to comply with this will result in thermal damage to current-carrying modules and the immediate vicinity thereof.

If the device is installed according to the recommendations in this manual, it meets all EMC directive requirements, as per the EMC product standard EN 61800-3.

2.4.2 Electrical connection of power unit

NOTICE

EMC interference to the environment

This device produces high-frequency interference, which may make additional suppression measures necessary in domestic environments 8.3 "Electromagnetic compatibility (EMC)".

- Use of shielded motor cables is essential in order to comply with the specified radio interference suppression level.

When the device is being connected, please note the following:

1. Ensure that the mains supply provides the correct voltage and is suitable for the current required (📖 Section 7 "Technical data").
2. Ensure that suitable electrical fuses with the specified nominal current range are installed between the voltage source and the device.
3. Mains cable connection: to terminals **L1-L2/N-L3** and **PE** (depending on device)
4. Motor connection: to terminals **U-V-W**

A 4-core motor cable must be used if the device is being wall-mounted As well as **U-V-W**, **PE** must also be connected. If present, in this case the cable shielding must be connected to a large area of the metallic screw connector of the cable gland.

The use of wire end rings is recommended for connecting to PE.



Information

Connection cables

Only use copper cables with temperature class 80°C or equivalent for connection. Higher temperature classes are permissible.

When using **wiring sleeves**, the maximum connection cross-section can be reduced.

Device	Cable Ø [mm²]		AWG	Tightening torque	
	rigid	flexible		[Nm]	[lb-in]
Size					
1 ... 2	0.2 ... 4	0.2 ... 6	24-10	0.5 ... 0.6	4.42 ... 5.31
Electromechanical brake					
1 ... 2	0.2 ... 2.5	0.2 ... 2.5	24-14	0.5 ... 0.6	4.42 ... 5.31

Table 6: Connection data

2.4.2.1 Mains supply (L1, L2(/N), L3, PE)

No special safety measures are required on the mains input side of the device. It is advisable to use normal mains fuses (see technical data) and a main switch or circuit breaker.

Frequency inverter data			Permissible mains data			
Type	Voltage	Power	1 ~ 115 V	1 ~ 230 V	3 ~ 230 V	3 ~ 400 V
SK...112-O	115 VAC	0.25 ... 0.75 kW	X			
SK...323-B	230 VAC	0.25 ... 1.10 kW		X	X	
SK...323-B	230 VAC	1.50 kW			X	
SK...340-B	400 VAC	≥ 0.25 kW				X
Connections			L/N = L1/L2	L/N = L1/L2	L1/L2/L3	L1/L2/L3

Isolation from or connection to the mains must always be carried out for all poles and synchronously (L1/L2/L3 or L1/N).

As delivered, the device is configured for operation in TN or TT networks. With this, the mains filter has its normal effect and leakage current. A network that is earthed in the neutral point must be used, and with single-phase devices a zero conductor must be used!

Adaptation to IT networks – (from size 2)

WARNING

Unexpected movement in case of mains faults

In case of a mains fault (earth fault), a frequency inverter which is switched off may switch on by itself. Depending on the parameterisation, this may cause the drive unit to start automatically and therefore cause a risk of injury.

- Secure the system against unexpected movement (block, decouple mechanical drive, provide protection against falling, etc.)

NOTICE

Operation in IT networks (size 2 and higher)

If a mains fault (earth fault) occurs in an IT network, the link circuit of a connected frequency inverter may become charged. This results in destruction of the link circuit capacitors due to overcharging.

- Connect the braking resistor

The braking resistor is used to dissipate excess energy and prevents damage to the device.

The switching threshold for activating the brake chopper is above the fault threshold. This ensures that an earth fault is detected and displayed via the error message “*Overvoltage Ud*”.

For operation on the IT network, simple adaptations must be carried out by relocating the jumpers (C_Y=OFF), which may result in impairment of the radio interference suppression.

The insulation resistance of the frequency inverter must be taken into consideration when operating on an insulation monitor ( Section 7 "Technical data").

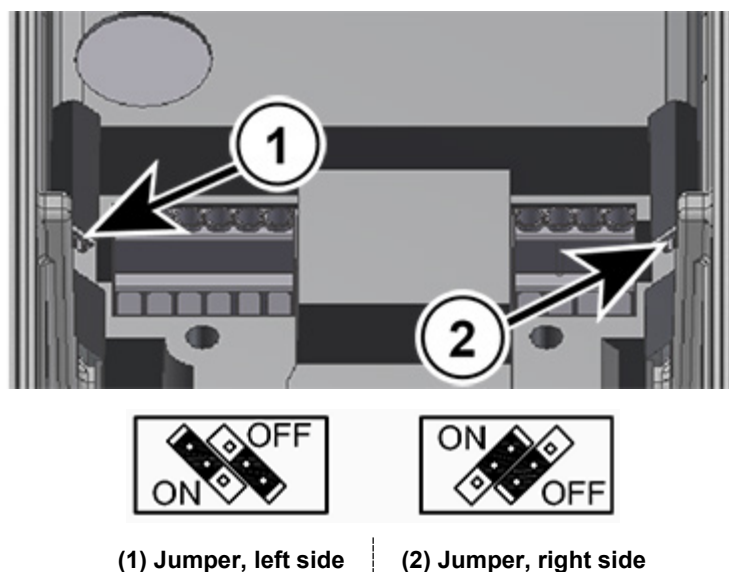

Figure 7: Jumpers for mains adaptation

Use with differing supply networks or network types

The frequency inverter may only be connect to and operated in supply networks which are explicitly stated in this section 2.4.2.1 "Mains supply (L1, L2(/N), L3, PE)". Operation in differing network types may be possible, but must be **explicitly checked and approved by the manufacturer in advance**.

2.4.2.2 Motor cable

The U, V, W and PE terminals are intended for connection of the motor cable. The motor cable may have a **total length of 50 m** if it is a standard cable type (observe EMC). If a shielded motor cable is used or if the cable is installed in a metallic and well-grounded duct, the total length should not exceed **20 m** (connect cable shield to PE at both ends).

NOTICE!

Output switching

Switching a motor cable under load causes an impermissible increase of the load on the device. Components in the power section may be damaged and destroyed either immediately or in the long term.

- Only switch the motor cable when the frequency inverter is no longer pulsing. I.e. the device must be in the state "ready for switch-on" or "switch-on block".



Information

Synchronous motors or multiple motor operation

If synchronous motors or several motors are connected in parallel to an FI, the frequency inverter must be switched over to linear voltage/frequency characteristic curves, ($\rightarrow P211 = 0$ and $P212 = 0$).

For multiple motor operation the total motor cable length consists of the sum of the individual motor cable lengths.

2.4.2.3 Braking resistor (+B, -B) – (from size 2)

The terminals +B/ -B are intended for the connection of a suitable braking resistor. A short screened connection should be selected.



CAUTION

Hot surfaces

The braking resistor and all other metal components may heat up to temperatures above 70 °C. If touched, there is a risk of injury from local burns. Adjacent objects may be damaged by heat.

- Allow sufficient cooling time before starting work on the product
- Check surface temperature by means of suitable measuring equipment
- Maintain an adequate distance to adjacent components

2.4.3 Electrical connection of the control unit

Connection data:

Terminal bar		X3	X4, X5
Cable Ø *	[mm ²]	0.2 ... 1.5	0.2 ... 1.5
Ø cable *	[mm ²]	0.2 ... 0.75	0.2 ... 0.75
AWG standard		24-16	24-16
Tightening torque	[Nm]	0.5 ... 0.6	Clamping
	[lb-in]	4.42 ... 5.31	
Slotted screwdriver	[mm]	2.0	2.0

* Flexible cable with wire-end ferrules, **without** plastic collar or rigid cable

** Flexible cable with wire-end ferrules with plastic collar (for cable cross-section 0.75 mm², a wire-end ferrule with a length of 10 mm must be used)

The device generates its own control voltage and provides this to terminal 43 (e.g. for connection of external sensor systems).



Information

Control voltage overload

A control unit overload caused by impermissibly high currents may destroy the unit. Impermissibly high currents occur if the total current that is actually withdrawn exceeds the permissible total current.

The control unit can also be overloaded and destroyed if the 24 V DC supply terminals of the device are connected to a different voltage source. For this reason, particularly when installing connectors for the control connection, it must be ensured that any cores for the 24 V DC power supply are not connected to the device but are insulated accordingly (example of connector for system bus connection SK TIE4-M12-SYSS).



Information

Total currents

If necessary, 24 V can be drawn from several terminals. This also includes e.g. digital outputs or an operating module connected via RJ45

The total current which is drawn off must not exceed 150 mA.



Information

Reaction time of digital inputs

The reaction time of a digital signal is approx. 4-5 ms and consists of the following:

Scan time	1 ms
Signal stability check	3 ms
Internal processing	< 1 ms



Information

Cable laying

All control cables (including thermistors) must be routed separately from the mains and the motor cables to prevent interference in the device.

If the cables are routed in parallel, a minimum distance of 20 cm must be maintained from cables which carry a voltage of > 60 V. The minimum distance may be reduced by screening the cables which carry a voltage, or by the use of earthed metal partitions within the cable conduits.

Alternatively: Use a hybrid cable with shielding of the control lines.

2.4.3.1 Control terminal details

Labelling, function

AIN:	Analogue input	DO:	Digital output
ASI+/-:	Integrated AS interface	DIN:	Digital input
10 V:	10 V DC reference voltage for AIN	SYS+/-:	System bus
24 V:	24 V DC control voltage	TF+/-:	Motor thermistor (PTC) connection
GND:	Reference potential for analogue and digital signals		

Connections depending on the development stage

Terminal X3:

Device type		SK 180E	SK 190E ASI
Pin	Labelling		
1	39	TF-	
2	38	TF+	

Terminal X4

Device type		SK 180E	SK 190E ASI
Pin	Labelling		
1	11	10V	
2	14	AIN1	
3	16	AIN2	
4	40	GND	
5	43	24V (output)	
6	21	DIN1	
7	22	DIN2	
8	23	DIN3	
9	1	DO1	
10	40	GND	
11	3	DO2	
12	40	GND	
13	77	SYS+	
14	78	SYS-	

Terminal X5 (only SK 190E):

Device type		SK 180E	SK 190E ASI
Pin	Labelling		
1	84		ASI+
2	85		ASI-

Meaning, Functions		Description / Technical data		
Terminal No.	Designation	Meaning	Parameter No.	Function of factory setting
Digital outputs		Signalling of device operating statuses		
		24 V DC With inductive loads: Provide protection via free-wheeling diode!	Maximum load 20 mA	
1	DOUT1	Digital output 1	P434 [-01]	Fault
3	DOUT2	Digital output 2	P434 [-02]	Fault

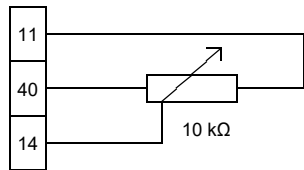
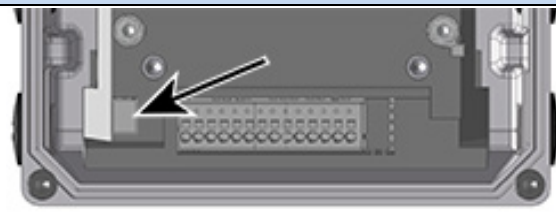
Analogue inputs		Actuation of device by external controller, potentiometer or the like.			
		<i>Resolution</i> 12Bit $U = 0 \dots 10 \text{ V}$, $R_i = 30 \text{ k}\Omega$ $I = 0/4 \dots 20 \text{ mA}$ <i>Burden resistance</i> (250 Ω) via DIP switch AIN1/2 Maximum permissible voltage at analogue input: 30 V DC	Matching of the analogue signals is performed via P402 and P403 . +10 V Reference voltage: 5 mA not short-circuit resistant		
					
11	10V REF	+10 V Reference voltage	-	-	
14	AIN1+	Analogue input 1	P400 [-01]	Setpoint frequency	
16	AIN2+	Analogue input 2	P400 [-02]	No function	
40	GND	Reference potential GND	-	-	
Digital inputs		Actuation of device using an external controller, switch or the like.			
		<i>as per EN 61131-2 Type 1</i> Low: 0-5 V (~ 9.5 k Ω) High: 15-30 V (~ 2.5 - 3.5 k Ω)	<i>Scan time:</i> 1 ms <i>Reaction time:</i> $\geq 4 \text{ ms}$ <i>Input capacitance:</i> 10 nF		
21	DIN1	Digital input 1	P420 [-01]	ON right	
22	DIN2	Digital input 2	P420 [-02]	ON left	
23	DIN3	Digital input 3	P420 [-03]	Fixed frequency 1 (\rightarrow P465[-01])	
Note: Inputs DIN2 and DIN3 react more quickly than DIN 1					
PTC resistor input		Monitoring of motor temperature using PTC			
		If the device is installed near the motor, a shielded cable must be used.	The input is always active. In order to make the device operational, a temperature sensor must be connected or both contacts must be jumpered.		
38	TF+	PTC resistor input	-	-	
39	TF-	PTC resistor input	-	-	
Control voltage source		Control voltage of device, e.g. for supplying accessories.			
		24 V DC $\pm 25 \%$, short circuit-proof	Maximum load 150 mA ¹		
43	VO / 24V	Voltage output	-	-	
40	GND / 0V	Reference potential GND	-	-	
¹ See "Total currents" information (📖 Section 2.4.3 "Electrical connection of the control unit")					
System bus		NORD-specific bus system for communicating with other devices (e.g. smart option modules or frequency inverter)			
		Up to four frequency inverters (SK 2xxE, SK 1x0E) can be operated on a single system bus.	\rightarrow Address = 32 / 34 / 36 / 38		
77	SYS H	System bus+	P509/P510	Control terminals / Auto	
78	SYS L	System bus-	P514/P515	250 kBaud / Address 32	
System bus terminating resistor		Termination at the physical ends of the bus system			
		The correct setting of the terminating resistors must be checked before commissioning. (1x at the beginning and 1x at the end of a system bus connection)			
S1				Factory setting "ON" (For deviating factory setting, see explanation above)	
AS Interface		Control of device via simple field bus level: Actuator/sensor interface			
		$26.5 - 31.6 \text{ V}$ $\leq 25 \text{ mA}$	Only usable for yellow AS interface cable, feed via black cable not possible.		
84	ASI+	ASI+	P480 ...	-	
85	ASI-	ASI-	P483	-	

Communication interface		Connection of the FI to various communication tools		
		24 VDC ± 20%	RS485 (for connecting a parametrisation box) 9600 ... 38400 Baud <i>Terminating resistor</i> (1 kΩ) fixed RS232 (for connection to a PC (NORDCON)) 9600 ... 38400 Baud	
1	RS485 A+	Data cable RS485	P502...	 1 - 2 - 3 - 4 - 5 - 6
2	RS485 B-	Data cable RS485	P513 [-02]	
3	GND	Bus signal reference potential		
4	RS232 TXD	Data cable RS232		
5	RS232 RXD	Data cable RS232		
6	+24 V	Voltage output		

Make sure that the diagnostic connection is sealed with the transparent screw cap (diagnostic glass) when not in use. This is the only way to ensure that the device achieves the specified protection class.

i Information

Use RJ12 plugs without latching tab

Only use RJ12 plugs without latching tab for connection to the diagnostic interface (RJ12 socket). Otherwise, the plug may get jammed in the RJ12 socket.

If necessary, remove the latching tab according to the figure and make sure that no burr remains.

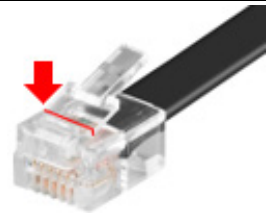

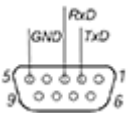
Connection cables (accessories / optional)	Connection of the device to an MS-Windows® PC with NORDCON software		
	Length: approx. 3.0 m + approx. 0.5 m Part number: 275274604 Suitable for connection to a USB port in a PC or alternatively to a SUB-D9 connection. Details: TI 275274604		

2.5 Operation in potentially explosive environments



WARNING

Danger of explosion due to electricity



Electric sparks may ignite an explosive atmosphere.

- Do not open the device in an explosive atmosphere and do not remove any covers (e.g. diagnostic openings).
- All work on the device must only be carried out with the **power to the system switched off**.
- Wait for the required time (≥ 30 min) after switching off.
- Before starting work, check that all relevant components (voltage source, connection cables, connection terminals of the device) are free of voltage using suitable measuring equipment.



WARNING

Explosion hazard due to high temperatures



High temperatures may cause the ignition of an explosive atmosphere.

Temperatures may occur within the device and the motor, which are higher than the maximum permissible surface temperature of the housing. Dust deposits may restrict the cooling of the device.

- Clean the device at regular intervals to prevent the accumulation of impermissible dust deposits.
- Do not open or remove the device from the motor in an explosive atmosphere.

With appropriate modification, the device can be used in certain potentially explosive areas.

If the device is connected to a motor and a gear unit, the EX labelling of the motor and the gear unit must also be observed. Otherwise the drive must not be operated.

2.5.1 Operation in potentially explosive environments - ATEX zone 22 3D

All of the conditions which must be observed for operation of the frequency inverter in an explosion hazard environment (ATEX) are listed below.

2.5.1.1 Modification of the device for compliance with category 3D

Only a specially modified device is permitted for operation in ATEX zone 22. This adjustment is exclusively made at the NORD site. In order to use the device in the ATEX zone 22, the diagnostic caps are replaced with anodised oil inspection glasses, among other things.



(1) Year of manufacture

(2) Labelling of the device (ATEX)

IP55:  II 3D Ex tc IIIB T125 °C Dc X

IP66:  II 3D Ex tc IIIC T125 °C Dc X

Assignment:

- Protected by a “housing”
- Method “A” Zone “22” Category 3D
- Protection class IP55/IP66 (depending on the device)
 - IP66 required for conductive dust
- Maximum surface temperature 125 °C
- Ambient temperature -20 °C to +40 °C

i Information

Possible damage caused by mechanical overload

Devices of the SK 1x0E series and the approved options are only designed for a degree of mechanical load which corresponds to a low impact energy of 7J.

Higher loads result in damages to or in the device.

The necessary components for making adaptations are contained in the ATEX kits.

Device	Kit designation	Part Number	Quantity	Document
SK 1x0E-... (IP55)	SK 1xxE-ATEX-IP55	275274207	1	TI 275274207
SK 1x0E-...-C (IP66)	SK 1xxE-ATEX-IP66	275274208	1	TI 275274208

2.5.1.2 Options for ATEX Zone 22, category 3D

In order to ensure that the device is ATEX-compliant, its optional modules must also be approved for potentially explosive areas. Option modules that are not in the following list may **not** be used in an ATEX zone 22 3D. This also includes connectors and switches that may also not be used in such an environment.

Control and parametrisation units are basically **not** approved for **operation in ATEX zone 22 3D**. They may therefore only be used for commissioning or maintenance purposes and if it has been ensured that no explosive dust atmosphere exists.

Designation	Part number	Use permissible?
Braking resistors		
SK BRI4-1-100-100	275272005	Yes
SK BRI4-1-200-100	275272008	Yes
SK BRI4-1-400-100	275272012	Yes
Busschnittstellen		
SK CU4-CAO(-C)	275271001 / (275271501)	Yes
SK CU4-DEV(-C)	275271002 / (275271502)	Yes
SK CU4-ECT(-C)	275271017 / (275271517)	Yes
SK CU4-EIP(-C)	275271019 / (275271519)	Yes
SK CU4-PBR(-C)	275271000 / (275271500)	Yes
SK CU4-PNT(-C)	275271015 / (275271515)	Yes
SK CU4-POL(-C)	275271018 / (275271518)	Yes
SK CU4-ETH(-C)	275271027 / (275271527)	Yes
IO extensions		
SK CU4-IOE(-C)	275271006 / (275271506)	Yes
SK CU4-IOE2(-C)	275271007 / (275271507)	Yes
SK CU4-REL(-C)	275271011 / (275271511)	Yes
Potentiometer		
SK ATX-POT	275142000	Yes
Other		
SK CU4-FUSE(-C)	275271122 / (275271622)	Yes
SK CU4-MBR(-C)	275271010 / (275271510)	Yes
SK CU4-SSR(-C)	265271124 / (275271625)	Yes
SK CU4-PD2(-C)	275271026 / (275271526)	Yes
Wall-mounting kits		
SK TIE4-WMK-1-EX	275175053	Yes
Adapter kits		
SK TI4-12-Adapterkit_63_71-EX	275175038	Yes

SK ATX-POT

The Category 3D frequency inverter can be equipped with an ATEX-compliant 10 kΩ potentiometer (SK ATX-POT), which can be used to setpoint (e.g. speed) adjustment on the device. The potentiometer is used with an M20-M25 extension in one of the M25 cable glands. The selected setpoint can be adjusted with a screwdriver. Due to the detachable screw closing cap, this component complies with ATEX requirements. Permanent operation may only be carried out with the cap closed.

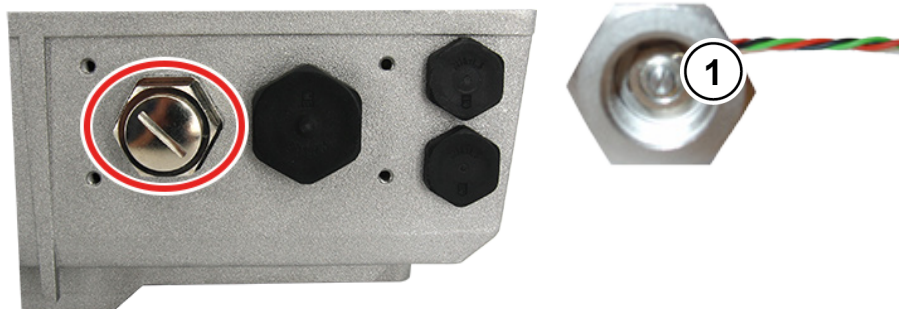

1 Setting adjustment using a screwdriver

SK ATX-POT wire colour	Name	Terminal SK CU4-24V...	Terminal SK CU4-IOE	Terminal SK 1x0E
red	+10 V reference	[11]	[11]	[11]
black	AGND / 0V	[12]	[12]	[12] / [40]
green	Analogue input	[14]	[14] / [16]	[14] / [16]

i Information

Internal braking resistor "SK BRI4-..."

If an internal braking resistor of type SK BRI4-x-xxx-xxx is used, the power limitation for this must be activated under all circumstances (Section 2.3.1 "Internal braking resistor SK BRI4-..."). Only the resistors assigned to the relevant inverter type may be used.

2.5.1.3 Maximum output voltage and torque reduction

As the maximum achievable output voltage depends on the pulse frequency to be set, in some cases the torque which is specified in document [B1091-1](#) must be reduced for values above the rated pulse frequency of 6 kHz.

For $F_{\text{pulse}} > 6 \text{ kHz}$: $T_{\text{reduction}}[\%] = 1 \% * (F_{\text{pulse}} - 6 \text{ kHz})$

Therefore the maximum torque must be reduced by 1 % for each kHz pulse frequency above 6 kHz. The torque limitation must be taken into account on reaching the break frequency. The same applies for the degree of modulation (P218). With the factory setting of 100 %, in the field reduction range a torque reduction of 5 % must be taken into account:

For $P218 > 100 \%$: $T_{\text{reduction}}[\%] = 1 \% * (105 - P218)$

Above a value of 105 %, no reduction needs to be taken into account. However, with values above 105 % no increase in torque above that of the Planning Guideline will be achieved. Under certain circumstances, degrees of modulation $> 100 \%$ may lead to oscillations and motor vibration due to increased harmonics.

i Information

Power derating

At pulse frequencies above 6 kHz (400 V devices) or 8 kHz (230 V) devices, the reduction in power must be taken into account for the design of the drive unit.

If parameter (P218) is set to < 105 %, the derating of the degree of modulation must be taken into account in the field reduction range.

2.5.1.4 Commissioning information

For Zone 22 the cable glands must at least comply with protection class IP55. Unused openings must be closed with blank screw caps that are suitable for ATEX Zone 22 3D (generally IP 55).



The motors are protected from overheating by the device. This takes place by means of evaluation of the motor PTC (TF) at the device side. In order to ensure this function, the PTC must be connected to the intended input (Terminal 38/39).

In addition, care must be taken that a NORD motor from the motor list (P200) is set. If a standard 4-pole NORD motor or a motor from a different manufacturer is not used, the data for the motor parameters ((P201) to (P208)) must be adjusted to those on the motor rating plate. *The stator resistance of the motor (see P208) must be measured by the inverter and at ambient temperature. In order to do this, parameter P220 must be set to "1".* In addition, the frequency inverter must be parameterised so that the motor can be operated with a maximum speed of 3000 rpm. For a four-pole motor, the "maximum frequency" must be set to a value which is smaller or equal to 100 Hz ((P105) ≤ 100). Here the maximum permissible output speed of the gear unit must be observed. In addition, the monitoring "I²t-Motor" (Parameter (P535) / (P533)) must be switched on and the pulse frequency set to between 4 kHz and 6 kHz.

Overview of required parameter settings:

Parameter	Setting value	Factory setting	Description
P105 Maximum frequency	≤ 100 Hz	[50]	This value relates to a 4-pole motor. On principle, the value must only be so large that a motor speed of 3000 rpm is not exceeded.
P200 Motor list	Select appropriate motor power	[0]	If a 4-pole NORD motor is used, the pre-set motor data can be called up.
P201 – P208 Motor data	Data according to rating plate	[xxx]	If a 4-pole NORD motor is not used, the motor data on the rating plate must be entered here.
P218 Degree of modulation	$\geq 100\%$	[100]	Determines the maximum possible output voltage
P220 Parameter identification	1	[0]	Measures the stator resistance of the motor. When the measurement is complete, the parameter is automatically reset to "0". The value that is determined is written to P208
P504 Pulse frequency	4 kHz ... 6 kHz	[6]	For pulse frequencies above 6 kHz a reduction of the maximum torque is necessary.
P533 Factor I ² t-Motor	< 100%	[100]	A reduction in torque can be taken into account with values less than 100 in the I ² t monitoring.
P535 I ² t motor	According to motor and ventilation	[0]	The I ² t- monitoring of the motor must be switched on. The set values depend on the type of ventilation and the motor used. See B1091-1

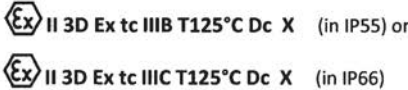
2.5.1.5 EU conformity declaration - ATEX

 <h1 style="margin: 0;">GETRIEBEBAU NORD</h1> <p style="margin: 0;">Member of the NORD DRIVESYSTEMS Group</p>																											
<p>Getriebebau NORD GmbH & Co. KG Getriebebau-Nord-Str. 1, 22941 Bargteheide, Germany · Fon +49(0)4532 289 - 0 · Fax +49(0)4532 289 - 2253 · info@nord.com C432410_1121</p>																											
<h2 style="margin: 0;">EU Declaration of Conformity</h2> <p style="margin: 0; font-size: small;">In the meaning of the directive 2014/34/EU Annex X, 2014/30/EU Annex II, 2009/125/EG Annex IV and 2011/65/EU Annex VI</p>																											
<p>Getriebebau NORD GmbH & Co. KG as manufacturer in sole responsibility hereby declares, Page 1 of 1 that the variable speed drives from the product series NORDAC BASE</p> <ul style="list-style-type: none"> • SK 180E-xxx-123-B-., SK 180E-xxx-323-B-., SK 180E-xxx-340-B-. • SK 190E-xxx-123-B-., SK 190E-xxx-323-B-., SK 190E-xxx-340-B-. <p>(xxx= 250, 370, 550, 750, 111, 151, 221)</p> <p>and the further options/accessories: SK CU4-PBR, SK CU4-CAO, SK CU4-DEV, SK CU4-PNT, SK CU4-ECT, SK CU4-POL, SK CU4-EIP, SK CU4-IOE, SK ATX-POT, SK BRI4-1-200-100, SK BRI4-1-400-100, SK TIE4-WMK-1, SK TIE4-M12-M16</p> <p>with ATEX labeling </p> <p>comply with the following regulations:</p> <table style="width: 100%; border-collapse: collapse;"> <tr> <td style="width: 30%;">ATEX Directive for products</td> <td style="width: 20%;">2014/34/EU</td> <td style="width: 50%;">OJ. L 96 of 29.3.2014, p. 309–356</td> </tr> <tr> <td>EMC Directive</td> <td>2014/30/EU</td> <td>OJ. L 96 of 29.3.2014, p. 79–106</td> </tr> <tr> <td>Ecodesign Directive</td> <td>2009/125/EG</td> <td>OJ. L 285 of 31.10.2009, p. 10–35</td> </tr> <tr> <td>Regulation (EU) Ecodesign</td> <td>2019/1781</td> <td>OJ. L 272 of 25.10.2019, p. 74–94</td> </tr> <tr> <td>RoHS Directive</td> <td>2011/65/EU</td> <td>OJ. L 174 of 1.7.2011, p. 88–11</td> </tr> <tr> <td>Delegated Directive (EU)</td> <td>2015/863</td> <td>OJ. L 137 of 4.6.2015, p. 10–12</td> </tr> </table> <p>Applied standards:</p> <table style="width: 100%; border-collapse: collapse;"> <tr> <td style="width: 33%;">EN 60079-0:2018</td> <td style="width: 33%;">EN 60079-31:2014</td> <td style="width: 33%;">EN 61800-9-1:2017</td> </tr> <tr> <td>EN 61800-5-1:2007+A1:2017</td> <td>EN 61800-3:2018</td> <td>EN 61800-9-2:2017</td> </tr> <tr> <td>EN 60529:1991+A1:2000+A2:2013+AC:2016</td> <td>EN 63000:2018</td> <td></td> </tr> </table> <p>It is necessary to notice the data in the operating manual to meet the regulations of the EMC-Directive. Specially take care about correct EMC installation and cabling, differences in the field of applications and if necessary original accessories.</p> <p>First marking was carried out in 2015.</p> <p>Bargteheide, 17.03.2021</p> <div style="display: flex; justify-content: space-around; margin-top: 20px;"> <div style="text-align: center;">  <p>U. Küchenmeister Managing Director</p> </div> <div style="text-align: center;">  <p>pp F. Wiedemann Head of Inverter Division</p> </div> </div>	ATEX Directive for products	2014/34/EU	OJ. L 96 of 29.3.2014, p. 309–356	EMC Directive	2014/30/EU	OJ. L 96 of 29.3.2014, p. 79–106	Ecodesign Directive	2009/125/EG	OJ. L 285 of 31.10.2009, p. 10–35	Regulation (EU) Ecodesign	2019/1781	OJ. L 272 of 25.10.2019, p. 74–94	RoHS Directive	2011/65/EU	OJ. L 174 of 1.7.2011, p. 88–11	Delegated Directive (EU)	2015/863	OJ. L 137 of 4.6.2015, p. 10–12	EN 60079-0:2018	EN 60079-31:2014	EN 61800-9-1:2017	EN 61800-5-1:2007+A1:2017	EN 61800-3:2018	EN 61800-9-2:2017	EN 60529:1991+A1:2000+A2:2013+AC:2016	EN 63000:2018	
ATEX Directive for products	2014/34/EU	OJ. L 96 of 29.3.2014, p. 309–356																									
EMC Directive	2014/30/EU	OJ. L 96 of 29.3.2014, p. 79–106																									
Ecodesign Directive	2009/125/EG	OJ. L 285 of 31.10.2009, p. 10–35																									
Regulation (EU) Ecodesign	2019/1781	OJ. L 272 of 25.10.2019, p. 74–94																									
RoHS Directive	2011/65/EU	OJ. L 174 of 1.7.2011, p. 88–11																									
Delegated Directive (EU)	2015/863	OJ. L 137 of 4.6.2015, p. 10–12																									
EN 60079-0:2018	EN 60079-31:2014	EN 61800-9-1:2017																									
EN 61800-5-1:2007+A1:2017	EN 61800-3:2018	EN 61800-9-2:2017																									
EN 60529:1991+A1:2000+A2:2013+AC:2016	EN 63000:2018																										

2.6 Outdoor installation

For outdoor installation of the device and technology units, the following requirements must be met:

- IP66 design (with UV-resistant blind plugs, see special measures, Section 1.9 "Version in protection class IP55, IP66")
- Anodised oil inspection glasses (part number: 201114000), quantity: 1
- Cover device to ensure protection against direct weather influences (rain/sun)
- Accessories used (e.g. plug connectors), also at least IP66

3 Display, operation and options



WARNING

Electric shock

When devices are open, electrically conducting elements (e.g. connection terminals, connection cables, PCBs, etc.) are freely accessible. These may be live, even if the device has been switched off.

- Avoid all contact.

As supplied, without additional options, the diagnostic LED is externally visible. This indicates the actual status of the device. In contrast, the AS-i LED (SK 190E) is only visible if the device is open.

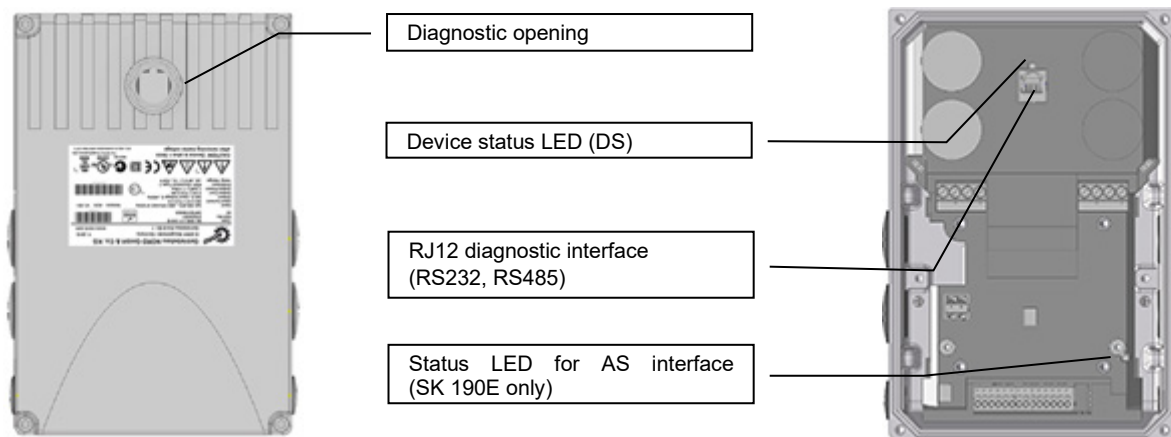

By using function-enhancing modules or modules for display, control and parameterisation, the device can be conveniently adapted to a wide range of applications.

Alpha-numeric display and control modules can be used for commissioning and parameter adaptation (📖 Section 3.1 "Control and parameterisation options").

For more complex tasks, software-based solutions are available.

Software	Description	Required accessories	Part number
NORDCON APP	Free control and parameterisation software for mobile terminal devices, available for iOS and Android, communication and Bluetooth	NORDAC ACCESS BT (SK TIE5-BT-STICK)	275900120
NORDCON	Free control and parameterisation software for Windows PC	Connection cable	275274604

3.1 Control and parametrisation options

Various control options are available that can be fitted directly to the device or in close proximity to it and directly connected.

Parametrisation units also provide a facility for accessing the parametrisation of the device and adapting it.

Designation		Part number	Document
Switch and potentiometer (attachment)			
SK CU4-POT	Switch/potentiometer	275271207	Section 3.2.4 "Potentiometer adapter, SK CU4-POT"
SK TIE4-POT	Potentiometer 0-10 V	275274700	TI 275274700
SK TIE4-SWT	"L-OFF-R" switch	275274701	TI 275274701
Control and parameterisation units (handheld)			
SK CSX-3H	SimpleBox	275281013	BU0040
SK PAR-5H	ParameterBox	275281614	BU0040

Connection of a control and parameterisation unit

1. Remove the diagnostics glass of the RJ12 socket.
2. Establish RJ12-RJ12 cable connection between control unit and Frequency Inverter.



Ensure that the latching tab on the connection side to the Frequency Inverter has been removed without burrs (see figure on the left). Otherwise, the plug may get jammed in the RJ12 socket.

As long as a diagnostics glass or a blind plug is open, make sure that no dirt or moisture enters the device.

3. After commissioning for regular operation, **reinsert all diagnostics glasses or blind plugs** and pay attention to **sealing**.



Information

Diagnostic caps' tightening torques

The tightening torque for the transparent diagnostic caps (inspection glasses) is 2.5 Nm.

3.1.1 Connection of multiple devices to one parametrisation tool

In principle it is possible to access several frequency inverters via the **ParameterBox** or the **NORDCON software**. In the following example, communication is made via the parameterisation tool, by tunnelling the protocols of the individual devices (max. 4) via the common system bus (CAN). The following points must be noted:

1. Physical bus structure

Establish a CAN connection (system bus) between the devices

2. Parameterisation

Parameter		Settings on the inverter							
No.	Designation	FI 1	FI 2	FI 3	FI 4				
P503	Leading function output	2 (system bus active)							
P512	USS address	0	0	0	0				
P513	Telegram time-out (s)	0.6	0.6	0.6	0.6				
P514	CAN bus baud rate	5 (250 kBaud)							
P515	CAN bus address	32	34	36	38				

3. Connect the parameterisation tool as usual via RS485 (e.g. via RJ12) to the **first** frequency inverter.

Conditions / Restrictions:

Basically, all of the currently available frequency converters from NORD can communicate via a common system bus. When devices in the SK 5xxE model series are incorporated, the framework conditions described in the manual for the device series concerned must be noted.

3.2 Optional modules

3.2.1 Internal customer interfaces SK CU4-... (installation of modules)

Internal customer units allow the scope of functionality of the devices to be extended without changing the physical size thereof. The device provides an installation location for the installing an appropriate option. If other option modules are required the external technology units must be used for these (📖 Section 3.2.2 "External technology units SK TU4-... (module attachment)").



Figure 8: internal customer units SK CU4 ... example

The bus interfaces require an external 24 V power supply, and are therefore also ready for operation if the device is not connected to the mains supply. Parameterisation and diagnosis of the bus interface is therefore possible independently from the frequency inverter.

Designation ¹⁾		Part number	Document
Bus interfaces			
SK CU4-ETH(-C)	Industrial Ethernet ²⁾	275271027 / (275271527)	TI 275271027 / (TI 275271527)
SK CU4-CAO(-C)	CANopen	275271001 / (275271501)	TI 275271001 / (TI 275271501)
SK CU4-DEV(-C)	DeviceNet	275271002 / (275271502)	TI 275271002 / (TI 275271502)
SK CU4-ECT(-C)	EtherCAT	275271017 / (275271517)	TI 275271017 / (TI 275271517)
SK CU4-EIP(-C)	Ethernet IP	275271019 / (275271519)	TI 275271019 / (TI 275274519)
SK CU4-PBR(-C)	PROFIBUS DP	275271000 / (275271500)	TI 275271000 / (TI 275271500)
SK CU4-PNT(-C)	PROFINET IO	275271015 / (275271515)	TI 275271015 / (TI 275271515)
SK CU4-POL(-C)	POWERLINK	275271018 / (275271518)	TI 275271018 / (TI 275271518)
IO extensions			
SK CU4-IOE(-C)		275271006 / (275271506)	TI 275271006 / (TI 275271506)
SK CU4-IOE2(-C)		275271007 / (275271507)	TI 275271007 / (TI 275271507)
SK CU4-REL(-C)		275271011 / (275271511)	TI 275271011 / (TI 275271511)
Other			
SK CU4-FUSE(-C)	Fuse module	275271122 / (275271622)	TI 275271122 / (TI 275271622)
SK CU4-MBR(-C)	El. brake rectifier	275271010 / (275271510)	TI 275271010 / (TI 275271510)
SK CU4-SSR(-C)	Solid state relay	275271124 / (275271624)	TI 275271124 / (TI 275271624)
SK CU4-SSR-400(-C)	Solid state relay	275271128 / (275271628)	TI 275271128 / (TI 275271628)
SK CU4-PD2(-C)	Power discharger	275271026 / (275271526)	TI 275271026 / (TI 275271526)

1) All modules marked with **-C** have varnished PCBs so that they can be used in IP6x devices.

2) Dialects that can be set: EtherCAT, EtherNet / IP, PROFINET IO

3.2.2 External technology units SK TU4-... (module attachment)

External technology units allow the scope of functionality of the devices to be extended in a modular way.

Depending on the type of module, different versions are available (differentiated according to IP protection class, with/without connector etc.). They can be fitted directly to the device using the relevant connection unit or in the vicinity of the device using an optional wall mounting kit.

Each SK TU4-... technology unit requires an associated SK T14-TU-... connection unit.



Figure 9: external technology units SK TU4-... (example)

With the bus modules or the I/O extension, it is possible to access the system bus via the RJ12 socket, which is located behind a transparent screwed cable gland (diagnostics glass). All active devices connected to the system bus (frequency inverters, additional SK xU4 modules) can thus be accessed via ParameterBox (SK PAR-5H) or the Windows-based NORDCON software.

The bus modules require a 24 V supply voltage. If the supply voltage is applied, the bus modules are also ready when the frequency inverter is not operating.

Type	IP55	IP66	M12	Designation	Part number	Document
Industrial Ethernet	X			SK TU4-ETH	275 281 132	TI 275281132
Dialects that can be set: EtherCAT, EtherNet / IP PROFINET IO		X		SK TU4-ETH-C	275 281 182	TI 275281182
	X		X	SK TU4-ETH-M12	275 281 233	TI 275281233
		X	X	SK TU4-ETH-M12-C	275 281 283	TI 275281283
CANopen	X			SK TU4-CAO	275 281 101	TI 275281101
		X		SK TU4-CAO-C	275 281 151	TI 275281151
	X		X	SK TU4-CAO-M12	275 281 201	TI 275281201
		X	X	SK TU4-CAO-M12-C	275 281 251	TI 275281251
DeviceNet	X			SK TU4-DEV	275 281 102	TI 275281102
		X		SK TU4-DEV-C	275 281 152	TI 275281152
	X		X	SK TU4-DEV-M12	275 281 202	TI 275281202
		X	X	SK TU4-DEV-M12-C	275 281 252	TI 275281252
EtherCAT	X			SK TU4-ECT	275 281 117	TI 275281117
		X		SK TU4-ECT-C	275 281 167	TI 275281167
EtherNet/IP	X		X	SK TU4-EIP	275 281 119	TI 275281119
		X	X	SK TU4-EIP-C	275 281 169	TI 275281169
POWERLINK	X			SK TU4-POL	275 281 118	TI 275281118
		X		SK TU4-POL-C	275 281 168	TI 275281168

Type	IP55	IP66	M12	Designation	Part number	Document
PROFIBUS DP	X			SK TU4-PBR	275 281 100	TI 275281100
		X		SK TU4-PBR-C	275 281 150	TI 275281150
	X		X	SK TU4-PBR-M12	275 281 200	TI 275281200
		X	X	SK TU4-PBR-M12-C	275 281 250	TI 275281250
PROFINET IO	X			SK TU4-PNT	275 281 115	TI 275281115
		X		SK TU4-PNT-C	275 281 165	TI 275281165
	X		X	SK TU4-PNT-M12	275 281 122	TI 275281122
		X	X	SK TU4-PNT-M12-C	275 281 172	TI 275281172
PROFIsafe	X			SK TU4-PNS	275 281 116	TI 275281116
		X		SK TU4-PNS-C	275 281 166	TI 275281166
	X		X	SK TU4-PNS-M12	275 281 216	TI 275281216
		X	X	SK TU4-PNS-M12-C	275 281 266	TI 275281266
I/O extension	X			SK TU4-IOE	275 281 106	TI 275281106
		X		SK TU4-IOE-C	275 281 156	TI 275281156
	X		X	SK TU4-IOE-M12	275 281 206	TI 275281206
		X	X	SK TU4-IOE-M12-C	275 281 256	TI 275281256
Required accessories (each module requires a corresponding adapter unit)						
Adapter unit	X			SK TI4-TU-BUS	275 280 000	TI 275280000
		X		SK TI4-TU-BUS-C	275 280 500	TI 275280500
Optional accessories						
Wall-mounting kit	X	X		SK TIE4-WMK-TU	275 274 002	TI 275274002

Table 7: external bus modules and IO extensions SK TU4- ...

Type	IP55	IP66	Designation	Part number	Document
PotentiometerBox 1~ 230 V	X		SK TU4-POT-123-B	275 281 110	TI 275281110
		X	SK TU4-POT-123-B-C	275 281 160	TI 275281160
PotentiometerBox 1~ 400 V	X		SK TU4-POT-140-B	275 281 111	TI 275281111
		X	SK TU4-POT-140-B-C	275 281 161	TI 275281161
Required accessories (each module requires a corresponding adapter unit)					
Adapter unit	X		SK TI4-TU-NET	275 280 100	TI 275280100
		X	SK TI4-TU-NET-C	275 280 600	TI 275280600
Optional accessories					
Wall-mounting kit	X	X	SK TIE4-WMK-TU	275 274 002	TI 275274002

Table 8: external PotentiometerBox SK TU4-POT- ...

Type	IP55	IP66	Designation	Part number	Document
Maintenance switch	X		SK TU4-MSW	275 281 123	TI 275281123
		X	SK TU4-MSW-C	275 281 173	TI 275281173
Required accessories (each module requires a corresponding adapter unit)					
Adapter unit	X		SK TI4-TU-MSW	275 280 200	TI 275280200
		X	SK TI4-TU-MSW-C	275 280 700	TI 275280700
Optional accessories					
Wall-mounting kit	X	X	SK TIE4-WMK-TU	275 274 002	TI 275274002

Table 9: external modules – maintenance switch SK TU4-MSW- ...

3.2.3 plug connectors

The use of optionally available plug connectors for power and control connections not only makes it possible to replace the drive unit with almost no loss of time in case of servicing, but also minimises the danger of installation errors when connecting the device. The most common plug connector versions are summarised below. The possible installation locations on the device are listed in section 2.2 "Installation of optional modules".

3.2.3.1 Plug connectors for power connections

Various connectors are available for the motor or mains connection.

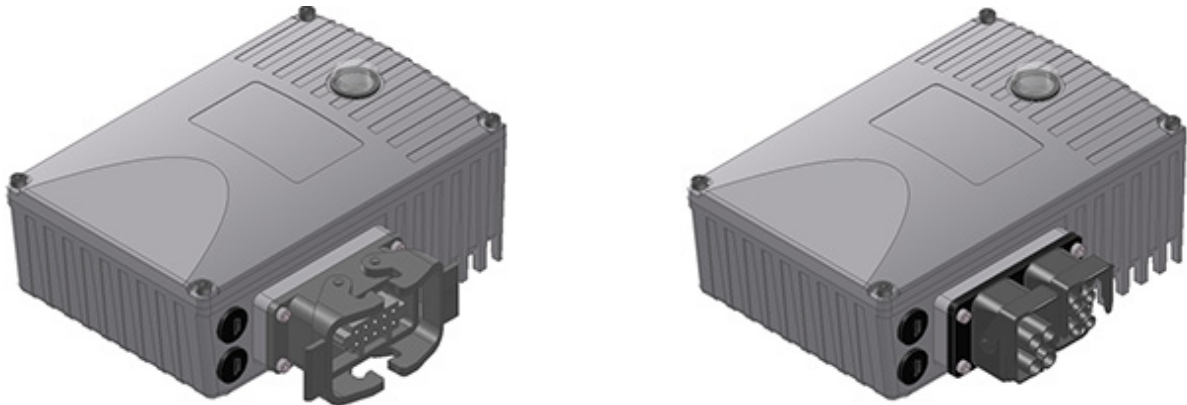

Figure 10: Examples of devices with connectors for connecting the power

3 different connections are available, which can also be combined (example "-LE-MA"):

Mounting version	Meaning
... - LE	Power input
... - LA	Power output
... - MA	Motor output

Connector (selection)

Type	Data	Designation	Material no.	Document
Power input	500 V, 16 A	SK TIE4-HANQ8-K-LE-MX	275 135 030	TI 275135030
Power input	500 V, 16 A	SK TIE4-HAN10E-M1B-LE	275 135 070	TI 275135070
Power input	500 V, 16 A	SK TIE4-HAN10E-M2B-LE	275 135 000	TI 275135000
Power input	690 V, 20 A	SK TIE4-QPD_3PE-K-LE	275 274 125	TI 275274125
Power input	630 V, 16 A	SK TIE4-NQ16-K-LE	275 274 133	TI 275274133
Power input + power outlet	400 V, 16 A	SK TIE4-2HANQ5-K-LE-LA	275 274 110	TI 275274110
Power input + motor outlet	600 V, 16 A	SK TIE4-2HANQ5-M-LE-MA-001	275 274 123	TI 275274123
Power output	500 V, 16 A	SK TIE4-HAN10E-M2B-LA	275 135 010	TI 275135010
Power output	500 V, 16 A	SK TIE4-HANQ8-K-LA-MX	275 135 040	TI 275135040
Motor output	500 V, 16 A	SK TIE4-HAN10E-M2B-MA	275 135 020	TI 275135020
Motor output	500 V, 16 A	SK TIE4-HANQ8-K-MA-MX	275 135 050	TI 275135050

i Information

Looping of the mains voltage

The permissible current load for the connection terminals, plugs and supply cables must be observed when looping the mains voltage. Failure to comply with this will result in thermal damage to current-carrying modules and the immediate vicinity thereof.

3.2.3.2 Plug connectors for control connection

Various M12 round plug connectors are available as flanged plugs or flanged sockets. The plug connectors are intended for installation in an M16 cable gland of the device, or in an external technology unit. The protection class (IP67) of the plug connector only applies in the screwed state. Similarly to the use of coding pins / grooves, the colour coding of the connectors (plastic unit inside and cover caps) is based on functional requirements and is intended to avoid erroneous operation.

Suitable expansion and reducer adapters are available for installation in M12 and M20 cable glands.



i Information

Control unit overload

The control unit of the device can be overloaded and destroyed if the 24 V DC supply terminals of the device are connected to another voltage source

For this reason, particularly when installing connectors for the control connection it must be ensured that any cores for the 24 V DC power supply are not connected to the device but are insulated accordingly (example of connector for system bus connection SK TIE4-M12-SYSS).

Connector (selection)

Type	Version	Designation	Part Number	Document
Power supply	Connector	SK TIE4-M12-POW	275 274 507	TI 275274507
Sensors / actuators	Socket	SK TIE4-M12-INI	275 274 503	TI 275274503
Initiators and 24 V	Connector	SK TIE4-M12-CAO	275 274 516	TI 275274516
AS Interface	Connector	SK TIE4-M12-ASI	275 274 502	TI 275274502
PROFIBUS (<i>IN + OUT</i>)	Plug connector + socket	SK TIE4-M12-PBR	275 274 500	TI 275274500
Analogue signal	Socket	SK TIE4-M12-ANA	275 274 508	TI 275274508
CANopen or DeviceNet <i>IN</i>	Connector	SK TIE4-M12-CAO	275 274 501	TI 275274501
CANopen or DeviceNet <i>OUT</i>	Socket	SK TIE4-M12-CAO-OUT	275 274 515	TI 275274515
Ethernet	Socket	SK TIE4-M12-ETH	275 274 514	TI 275274514
System bus <i>IN</i>	Connector	SK TIE4-M12-SYSS	275 274 506	TI 275274506
System bus <i>OUT</i>	Socket	SK TIE4-M12-SYSM	275 274 505	TI 275274505

3.2.4 Potentiometer adapter, SK CU4-POT

Part no.: 275 271 207

The digital signals R and L can be directly applied to the frequency inverter's digital inputs 1 and 2.

The potentiometer (0 - 10 V) can be evaluated via an analogue input from the frequency inverter or from an I/O extension.



Module		SK CU4-POT (Part no.: 275 271 207)	Connection: Terminal no.		Function
Pin	Colour		SK 1x0E		
1	Brown	24 V supply voltage	43		Rotary switch L - OFF - R
2	Black	Enable R (e.g. DIN1)	21		
3	White	Enable L (e.g. DIN2)	22		
4	White	Tap on AIN1+	14		Potentiometer 10 kΩ
5	Brown	Reference voltage 10 V	11		
6	Blue	Analogue ground AGND	12		

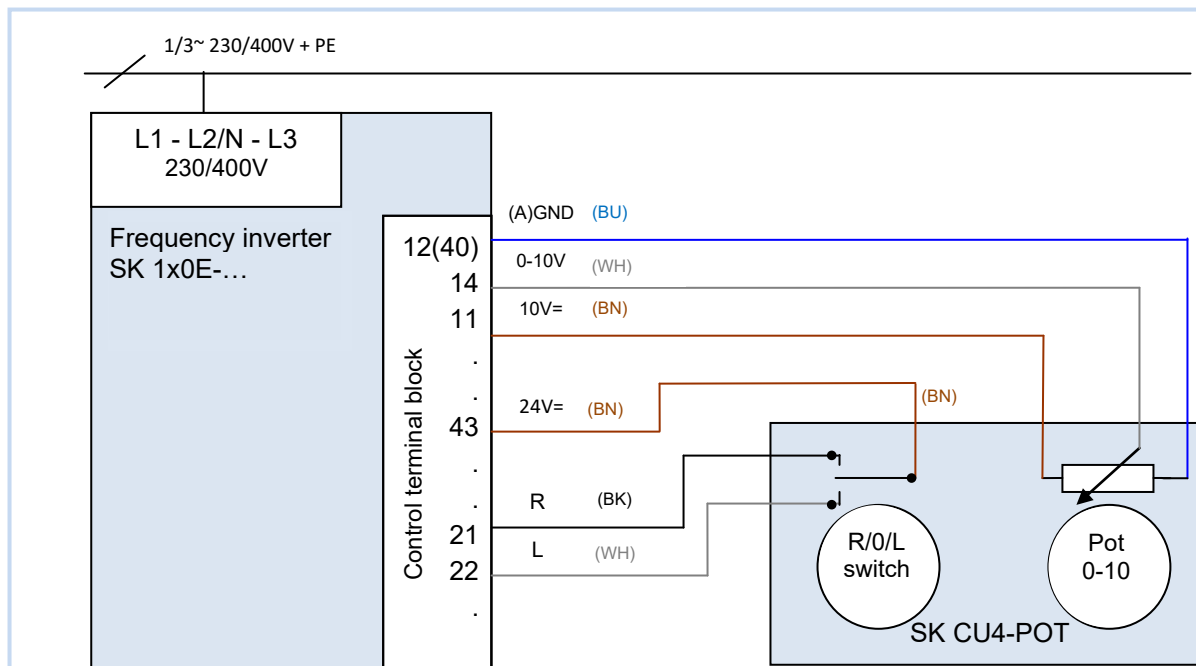

Figure 11: Wiring diagram SK CU4-POT, example SK 1x0E

4 Commissioning

WARNING

Unexpected movement

Connection of the supply voltage may directly or indirectly set the device into motion. This can cause unexpected movement of the drive and the attached machine, which may result in serious or fatal injuries and/or material damage. Possible causes of unexpected movements are e.g.:

- Parameterisation of an “automatic start”
 - Incorrect parameterisation
 - Control of the device with an enabling signal from a higher level control system (via IO or bus signals)
 - Incorrect motor data
 - Incorrect encoder connection
 - Release of a mechanical holding brake
 - External influences such as gravity or other kinetic energy which acts on the drive unit
 - In IT networks: Mains fault (earth fault)
- To avoid any resulting hazard, the drive / drive chain must be secured against unexpected movements (mechanical blocking and/or decoupling, provision of protection against falling etc.) In addition, it must be ensured that there are no persons within the area of action and the danger area of the system.

4.1 Factory settings

All frequency inverters supplied by Getriebebau NORD are pre-programmed with the default setting for standard applications with 4-pole three-phase standard motors (same power and voltage). For use with motors with other powers or number of poles, the data from the name plate of the motor must be entered into the parameters **P201...P207** under the menu item >Motor data<.

All motor data (IE1, IE4) can be pre-set with parameter **P200**. After the function has been used, this parameter is reset to 0 = no change! The data is automatically loaded once into parameter **P201...P209** and can be compared with the data on the motor type plate.

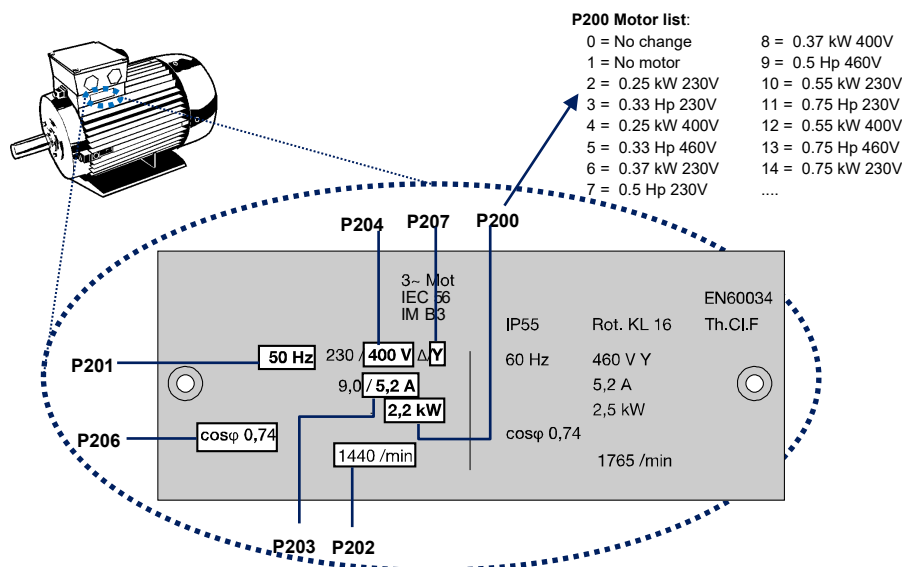

For correct operation of the drive unit, it is necessary to set the motor data as accurately as possible in accordance with the name plate. In particular, automatic stator resistance measurement using parameter **P220** is recommended.

4.2 Selecting the operating mode for motor control

The frequency inverter is able to control motors with efficiency classes IE1 to IE5+. Our motors are designed as asynchronous motors in efficiency classes IE1 to IE3, and IE4 and IE5+ motors are designed as synchronous motors.

In terms of control technology, the operation of synchronous motors shows many special features. In order to achieve ideal results, the frequency inverter was therefore designed for the control of synchronous motors from NORD, which match the type of an IPMSM (Interior Permanent Magnet Synchronous Motor) in terms of structure. In these motors, the permanent magnets are embedded in the rotor. The operation of other manufacturer's motors must be checked by NORD, if required. See also technical information [TI 60-0001](#), "Planning and commissioning guide for NORD synchronous motors (PMSM) with NORD frequency inverters" and the application guide [AG0101](#), "Drive optimisation: Guideline for PMSM – CFC Closed-Loop".

4.2.1 Explanation of the operating modes (P300)

The frequency inverter provides different operating modes for the control of a motor. All operating modes can be used with either an ASM (asynchronous motor) or a PMSM (Permanent Magnet Synchronous Motor), however various constraints must be complied with. In principle, all these methods are "flux oriented control methods.

- VFC open-loop mode (**P300 = 0**)

This operating mode is based on a voltage-controlled, field-oriented control method (Voltage Flux Control Mode "VFC"). It is used with ASM and PMSM. In the context of the operation of asynchronous motors, the term "ISD control" is also used.

Control takes place without encoder and only based on fixed parameters and measurement results of actual electrical values. No specific setting of the speed control is required to use this operating mode. However, the parameterisation of motor data as precisely as possible is an essential condition for high-quality operation.

For the ASM mode, there is also the possibility of control according to a simple V/f characteristic curve. This mode is suitable for the operation of several, mechanical, non-coupled motors in parallel on one frequency inverter, or if the motor data cannot be precisely determined.

Operation according to a V/f characteristic curve is only suitable for drive applications with low requirements on speed quality and dynamics (ramp times ≥ 1 s). Even for machinery that, due to its design, tends towards mechanical vibrations, control according to a V/f characteristic curve may be advantageous. V/f characteristic curves are usually used to control fans, certain pump drives, or for agitators. Operation according to V/f characteristic curve is activated via the parameters **P211 = 0** and **P212 = 0**.

4.2.2 Overview of control parameter settings

The following provides an overview of all parameters which are of importance, depending on the selected operating mode. Among other things, a distinction is made between "relevant" and "important", which provides an indication of the required precision of the particular parameter setting. However, in principle, the more precisely the setting is made, the more exact the control, so that higher values for dynamics and precision are possible for the operation of the drive unit. A detailed description of these parameters can be found in Section 5 "Parameter".

		"∅" =	Parameter has no significance		"-" =	Leave the parameter in the factory setting	
		"√" =	Setting of the parameter is relevant		"!" =	Setting of the parameter is important	
Group	Parameter	Operating mode					
		VFC open-loop		CFC open-loop			
		ASMs	PMSMs	ASMs	PMSMs		
Motor data	P201 ... P209	√	√	√	√		
	P208	!	!	!	!		
	P210	√ ¹⁾	√	√	√		
	P211, P212	- ²⁾	-	-	-		
	P215, P216	- ¹⁾	-	-	-		
	P217	√	√	√	√		
	P220	√	√	√	√		
	P240	-	√	-	√		
	P241	-	√	-	√		
	P243	-	√	-	√		
	P244	-	√	-	√		
	P246	-	√	-	√		
	P245, 247	-	√	∅	∅		
Controller data	P300	√	√	√	√		
	P301	∅	∅	∅	∅		
	P310 ... P320	∅	∅	√	√		
	P312, P313, P315, P316	∅	∅	-	√		
	P330 ... P333	-	√	-	√		
	P334	∅	∅	∅	∅		
¹⁾ =		For V/f characteristic curve: precise matching of the parameter is important.					
²⁾ =		For V/f characteristic curves: typical setting "0"					

4.2.3 Motor control commissioning steps

The main commissioning steps are mentioned below in their ideal order. Correct assignment of the inverter / motor and the mains voltage is assumed. Detailed information, especially for optimisation of the current, speed and position control of asynchronous motors is described in the guide "Control optimisation" (AG 0100). Please contact our Technical Support.

1. Make the motor connection as usual (note Δ / Y!)
2. Connect the mains supply.

3. Carry out the factory setting (P523)
4. Select the basic motor from the motor list (P200) (ASM types are at the beginning of the list, PMSM types are at the end, designated by their type (e.g. ...**80T**...))
5. Check the motor data (P201 ... P209) and compare with the type plate / motor data sheet
6. Measure the stator resistance (P220) → P208, P241[-01] are measured, P241[-02] is calculated.
(Note: if an SPMSM is used, P241[-02] must be overwritten with the value from P241[-01])
7. with PMSM only:
 - a. EMF voltage (P240) → motor type plate / motor data sheet
 - b. Determine / set reluctance angle (P243) (not required with NORD motors)
 - c. Peak current (P244) → motor data sheet
 - d. Only for PMSMs in VFC mode:
determine (P245), (P247)
 - e. Determine (P246)
8. Select the operating mode (P300)
9. Determine / adjust the current control (P312 – P316)
10. PMSM only:
 - a. Select the control method (P330)
 - b. Make the settings for the starting behaviour (P331 ... P333)

Information

NORD IE4 Motors

Further information for commissioning NORD IE4 motors with NORD frequency inverters can be found in the technical information [TI80_0010](#).

4.3 Starting up the device

The frequency inverter can be commissioned by making parameter adjustments using control and parametrisation units (SK CSX-3H or SK PAR-5H) or by using software (NORDCON or NORDCON APP). For this, parameter changes are stored in the internal EEPROM.

i Information **Presetting of physical I/O and I/O bits**

For commissioning standard applications, a limited number of the frequency inverter inputs and outputs (physical and I/O bits) have predefined functions. These settings may need to be changed (Parameters (P420), (P434), (P480), (P481)).

4.3.1 Connection

In order to provide basic operational capability, after the device has been attached to the motor or the wall mounting kit, the power and motor lines must be connected to the relevant terminals (📖 Section 2.4.2 "Electrical connection of power unit").

4.3.2 Configuration

Changes to individual parameters are usually necessary for operation.

4.3.2.1 Parameterisation

The use of a ParameterBox (SK CSX-3H / SK PAR), the NORDCON software or the NORDCON APP is required in order to adapt the parameters.

Parameter group	Parameter numbers	Functions	Remarks
Basic parameter	P102 ... P105	Ramp times and frequency limits	
Motor data	P201 ... P207, (P208)	Type plate data for motor	
	P220, Function 1	Calibrate stator resistance	Value is written to P208
	alternatively P200	Motor data list	Selection of a 4-pole NORD standard motor from a list
	alternatively P220, Function 2	Motor identification	Complete calibration of a connected motor Condition: Motor is not more than 3 power levels smaller than frequency inverter
Control terminals	P400, P420	Analogue/digital inputs	

i Information **Factory settings**

Prior to restarting, it should be ensured that the frequency inverter is in its factory settings (P523).

The DIP switches S2 should remain in the "OFF" setting. The DIP switches S2 have priority over parameters P509, P514 and P515.

4.3.2.2 DIP switches (S1, S2)

The analogue inputs in the device are suitable for current and voltage setpoints. For correct processing of current setpoints (0-20 mA / 4-20 mA) the relevant DIP switch (**S1** – bit 2 or 3) must be set to current signals ("ON").

DIP switch (**S1** – bit 1) sets the terminating resistance of the system bus.

The system settings can be made via DIP switch (**S2**). Settings made at DIP switch (S2) have priority over the parameters P509, P514 and P515.

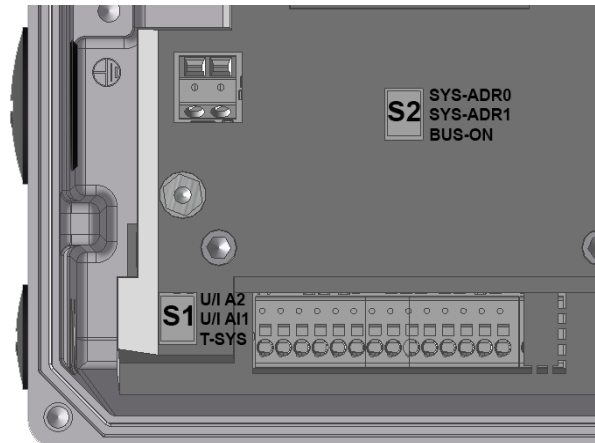

As delivered, all DIP switches are in the "0" ("OFF") position.

No.

Bit DIP switch (S1)

3	U/I A2 ¹⁾ Voltage / current	0	Analogue input 2 in voltage mode 0...10 V
		1	Analogue input 2 in current mode 0/4...20 mA
2	U/I AI1 ¹⁾ Voltage / current	0	Analogue input 1 in voltage mode 0...10 V
		1	Analogue input 1 in current mode 0/4...20 mA
1	T-SYS Terminating resistance	0	System bus terminating resistance deactivated
		1	System bus terminating resistance activated

1) Adjustment to fail-safe signals in case of cable breaks (2-10 V / 4-20 mA) is made via parameters P402 and P403.

No.

Bit DIP switch (S2)

3/2	SYS-ADR 0/1 System bus Address/ baud rate	SYS-ADR		
		1	0	
		0	0	In accordance with P515 and P514 [32, 250kBaud]
		0	1	Address 34, 250 kBaud
		1	0	Address 36, 250 kBaud
1	BUS-ON Control word and setpoint value source	0	In accordance with P509 and P510 [-01, -02]	
		1	System bus (→ P509=3 and P510=3)	

4.3.3 Commissioning examples

All SK 1x0E models can be operated as delivered. Standard motor data for a 4-pole standard asynchronous motor of the same power is parameterised. The PTC input must be bypassed, if a motor with PTC is not available. Parameter (P428) must be changed if an automatic startup with "Mains On" is required.

Minimal configuration

The frequency inverter provides all the necessary control voltages (24 VDC / 10 VDC).

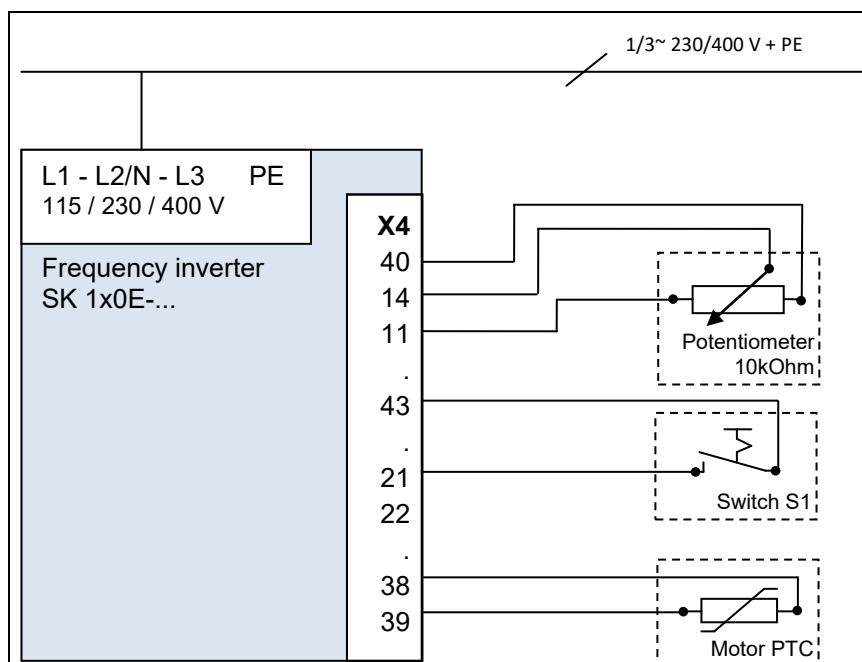

Function	Setting
Setpoint	External 10 kΩ potentiometer
Approval	External switch S1

Minimal configuration with options

In order to implement completely autonomous operation (independent of control cables etc.) a switch and a potentiometer such as potentiometer adapter SK CU4-POT is required. In this way, the speed and direction control in accordance with requirements can be achieved with only a single mains cable (single phase or three-phase depending on version) (📖 Section 3.2.4 "Potentiometer adapter, SK CU4-POT"),

4.4 Temperature sensors

The current vector control of the frequency inverter can be further optimised by the use of a *temperature sensor*. By continuous measurement of the motor temperature, the highest control precision of the frequency inverter and the associated optimum speed precision of the motor is achieved at all times and with any load. As the temperature measurement starts immediately after (mains) switch-on of the frequency inverter, the frequency inverter provides immediate optimum control, even if the motor has a considerably increased temperature after an intermediate “Mains off/Mains on” of the frequency inverter.

Information

Determination of motor stator resistance

To determine the stator resistance of the motor, the temperature range 15 ... 25 °C should not be exceeded in either direction.

The motor overtemperature is also monitored and at 155 °C (switching threshold as with the PTC resistor) causes the drive to switch off with error message E002.

Information

Pay attention to polarity

Temperature sensors are wired semiconductors that must be operated in the conducting direction. For this, the anode must be connected to the "+" contact of the analogue input. The cathode must be connected to earth.

Failure to observe this can lead to false measurements. Motor winding protection is therefore no longer guaranteed.

Approved temperature sensors

The function of the approved temperature sensors is comparable. However, their characteristic curves differ. Correct matching of the characteristic curves to the frequency inverter is made by changing the following two parameters.

Sensor type	Shunt resistor [kΩ]	P402[xx] ¹⁾ 0% adjustment [V]	P403[xx] ¹⁾ 100% adjustment [V]
KTY84-130	2.7	1.54	2.64
1) xx = parameter array, depending on the analogue input used			

Table 10: Temperature sensors, adjustment

Connection of a temperature sensor is made according to the following examples.

Taking into account the relevant values for the 0% adjustment [P402] and 100% adjustment [P403], these examples can be used for all of the approved temperature sensors which are stated above.

Connection examples

SK CU4-IOE / SK TU4-IOE-...

Connection of a KTY-84 to either of the two analogue inputs of the relevant option is possible. In the following examples, analogue input 2 of the particular optional module is used.

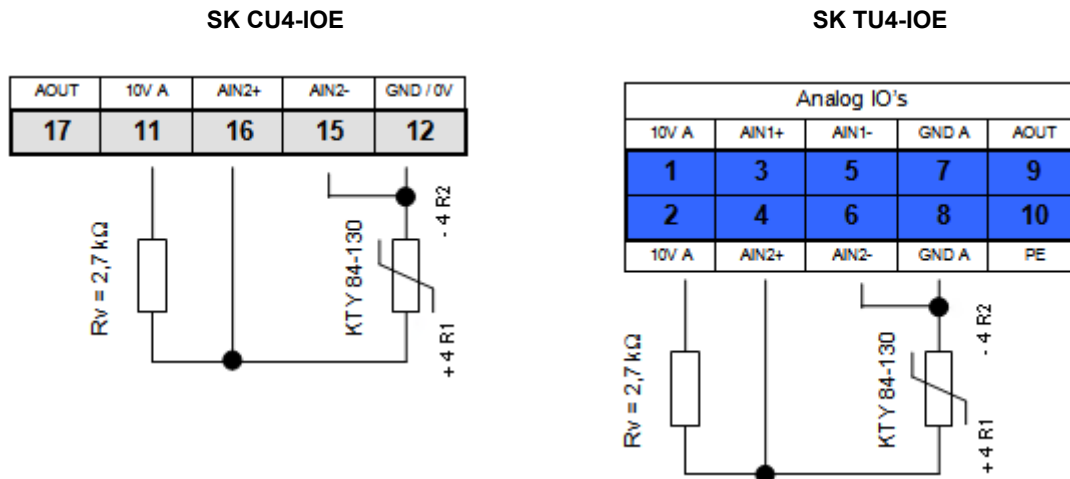

(Illustration shows a section of the terminal strips)

Parameter settings (Analogue input 2)

The following parameters must be set for the function of the KTY84-130.

1. The motor data **P201-P207** must be set according to the rating plate.
2. The motor stator resistance **P208** is determined at 20°C with **P220 = 1**.
3. Analogue input 2 function, **P400 [-04] = 30**
(motor temperature)
4. The mode analogue input 2 **P401 [-02] = 1**
(negative temperatures are also measured)
(As of firmware version: V1.2)
5. Adjustment of analogue input 2: **P402 [-02] = 1.54 V** and **P403 [-02] = 2.64 V**
(with $R_v = 2.7 \text{ k}\Omega$)
6. Adjust time constants: **P161 [-02] = 400ms** (Filter time constant is at a maximum)
Parameter (P161) is a module parameter. It cannot be set at the frequency inverter, but must be set directly at the I/O module.
Communication takes place by directly connecting a ParameterBox to the RS232 interface of the module, for example, or by means of connecting to the frequency converter via the system bus. (Parameter (P1101) object selection → ...)
7. Motor temperature control (display): **P739 [-03]**

SK 1x0E

Connection of a KTY-84 to either of the two analogue inputs of the **SK 1x0E** is possible. In the following examples, analogue input 2 of the frequency inverter is used.

SK 1x0E

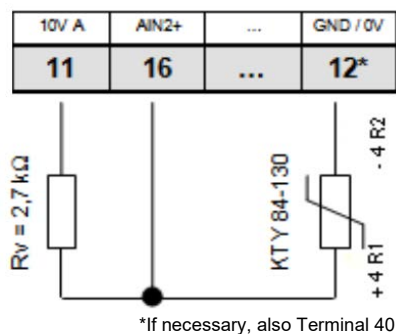

Parameter settings (Analogue input 2)

The following parameters must be set for the function of the KTY84-130.

1. The motor data **P201-P207** must be set according to the rating plate.
2. The motor stator resistance **P208** is determined at 20°C with **P220 = 1**.
3. Function analogue input 2, **P400 [-02] = 30**
(Motor temperature)
4. The mode analogue input 2 **P401 [-06] = 1**
(negative temperatures are also measured)
5. Adjustment of analogue input 2: **P402 [-06] = 1.54 V** and **P403 [-06] = 2.64 V**
(with RV= 2.7 kΩ)
6. Adjust time constants: **P404 [-02] = 400 ms** (Filter time constant is maximum)
7. Motor temperature control (display): **P739 [-03]**

4.5 AS Interface (AS-i)

This section is only relevant for device of type SK 190E .

4.5.1 The bus system

General information

The **Actuator Sensor Interface (AS-Interface)** is a bus system for the lower field bus level. It has been defined in the AS-Interface *Complete Specification* and standardised according to EN 50295, IEC62026.

The transfer principle is a single-master system with cyclic polling. Since the *Complete Specification V2.1* , a maximum of **31 standard slaves** using the device profile **S-7.0.**, or **62 slaves in the extended addressing mode** using the device profile **S-7.A.** could have been operated with any network structure at an unshielded two-wire line up to 100 m long.

Doubling the number of possible slaves is implemented by the double assignment of the addresses 1-31 and the “A slave” or “B slave” labelling. Slaves in the extended addressing mode are labelled by the ID code A and can be clearly identified by the master.

Devices with slave profiles **S-7.0** and **S-7.A.** can be operated together within an AS-i network with version 2.1 and higher (**master profile M4**), considering the address assignment (see example).

Permissible	Not permissible
Standard slave 1 (address 6)	Standard slave 1 (address 6)
A/B slave 1 (address 7A)	Standard slave 2 (address 7)
A/B slave 2 (address 7B)	A/B slave 1 (address 7B)
Standard slave 2 (address 8)	Standard slave 3 (address 8)

Addressing is done via the master that also provides further management functions, or via a separate addressing unit.

Device-specific information

The transfer of the 4-bit application data (per direction) is performed with effective error protection for standard slaves with a maximum cycle time of 5 ms. Due to the higher number of participants, for slaves in the extended addressing mode, the cycle time is doubled (*max. 10 ms*) for data sent *from the slave to the master*. Extended addressing for sending data *to the slave* cause an additional doubling of the cycle time to *max. 21 ms*.

The AS-Interface cable (yellow) transfers data and power.

4.5.2 Features and technical data

The device can be directly integrated in an AS interface network is parametrised in its factory settings so that the most frequently used AS-i functionality is available immediately. Only adaptations for application-specific functions of the device or the bus system, the addressing and proper connection of the supply, BUS, sensor and actuator cables need to be carried out.

Features

- Electrically isolated bus interface
- Status indicator (1 LED) (only visible with the cover of the device open)
- Configuration by means of parametrisation
- 24 V DC supply of integrated AS-i module via yellow AS-i line
- Connection to device
 - Via terminal strip
 - or via M12 flange connector

Technical data for AS interface

Designation	Value
AS-i supply, PWR connection (yellow cable)	24 V DC, max. 25 mA
Slave profile	S-7.A
I/O-Code	7
ID Code	A
External ID Code 1 / 2	7
Address	1A – 31A and 1B - 31B (Delivery condition 0A)
Cycle time	Slave → Master ≤ 10 ms Master → Slave ≤ 21 ms
Quantity of (BUS I/O)	4I / 4O

4.5.3 Bus structure and topology

The AS-Interface network structure is optional (line, star, ring and tree structure) and is managed by an AS-Interface master as an interface between PLC and slaves. An existing network can be extended with further slaves up to a limit of 31 standard slaves or 62 slaves in the extended addressing mode. The addressing of slaves is done by the master or a respective addressing unit.

An AS-i master communicates independently and exchanges data with the connected AS-i slaves. No standard power supply units must be used in the AS-Interface network. For each AS-Interface line, only one special AS-Interface power supply unit may be used for voltage supply. This AS-Interface voltage supply is connected directly to the yellow standard cable (AS-i(+)) and AS-i(-) cable) and should be positioned as close as possible to the AS-i master to keep the voltage drop low.

To avoid interferences, the **PE connection of the AS-Interface power supply unit** (if available) **must be earthed**.

The brown **AS-i(+)** and the blue **AS-i(-)** wire of the yellow AS-Interface cable **must not be earthed**.

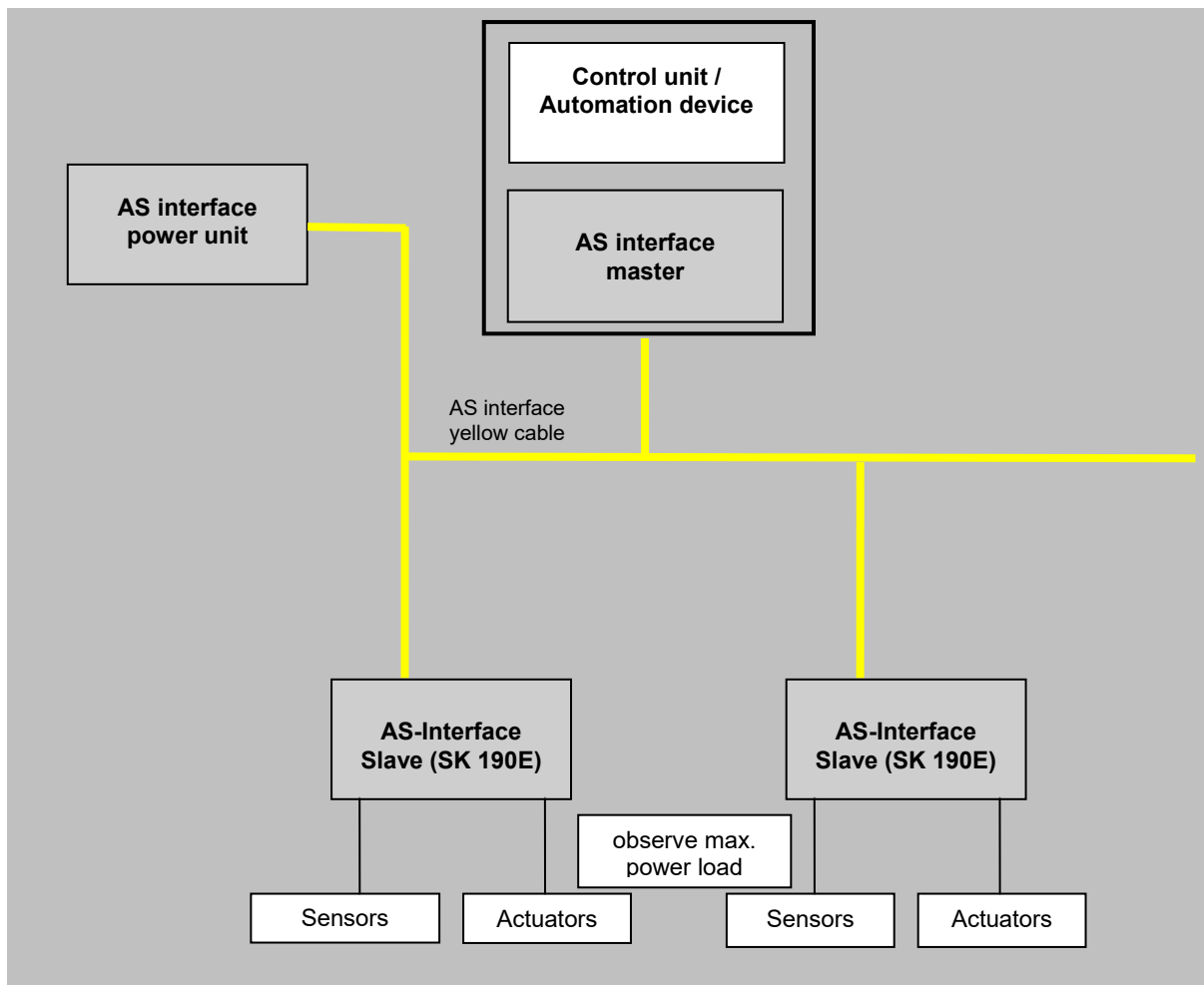

4.5.4 Commissioning

4.5.4.1 Connection

Connection of the AS interface cable (yellow) is made via terminals 85/85 of the terminal strip and can optionally be made to an appropriately labelled M12 flange plug connector (yellow)

Details of control terminals (📖 Section 2.4.3 "Electrical connection of the control unit")

Details of connector (📖 Section 3.2.3.2 "Plug connectors for control connection")

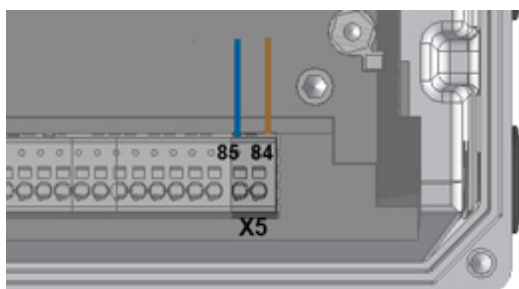

Figure 12: Connecting terminals AS-i

Type	Connection of AS-Interface ¹⁾	
	AS-i(+)	AS-i(-)
SK 190E	84	85

1) The control unit of the frequency inverter is not supplied via the AS-i cable. The required auxiliary voltage is generated by the unit itself.

Table 11: AS-Interface, connection of signal and supply cables

If the AS interface ("yellow cable") is not used, the normal connection requirements for the device apply (📖 Section 2.4.3 "Electrical connection of the control unit").

4.5.4.2 Displays

The status of the AS interface is signalled by a multi-colour **AS-i** LED.

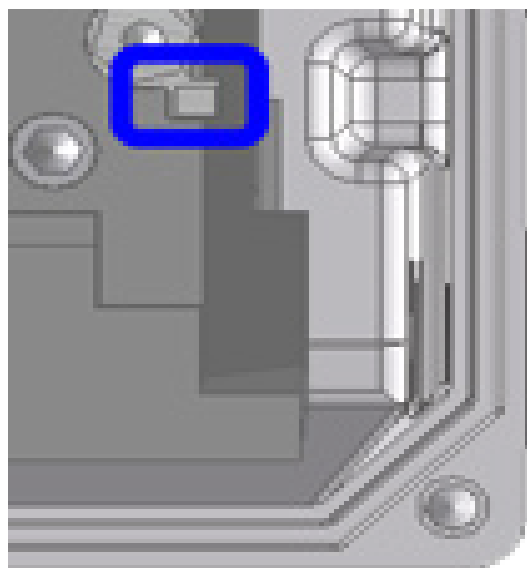

AS-i LED	Meaning
OFF	<ul style="list-style-type: none"> No AS interface voltage to the module Connections not connected or exchanged
green ON	<ul style="list-style-type: none"> Normal operation (AS interface active)
red ON	<ul style="list-style-type: none"> No exchange of data <ul style="list-style-type: none"> Slave address = 0 (slave still in factory setting) Slave not in LPS (list of planned slaves) Slave with incorrect IO/ID Master in STOP mode Reset active
Alternately flashing red / green Flashing (2 Hz) ¹⁾	<ul style="list-style-type: none"> Peripheral error <ul style="list-style-type: none"> Control unit in device not starting (AS-i voltage too low or control unit defective)

4.5.4.3 Configuration

The most important functionality is assigned via the arrays [-01] ... [-04] of parameters (P480) and (P481).

Bus I/O bits

⚠ WARNING

Unexpected movement due to automatic starting

In the event of a fault (communication interrupted or bus cable disconnection) the device automatically switches off, since the device enable is no longer present.

Restoration of communication may result in an automatic start and therefore unexpected movement of the drive unit. To prevent any hazard, a possible automatic start must be prevented as follows:

- If a communication error occurs, the bus master must actively set the control bits to “zero”.

Initiators can be directly connected to the digital inputs of the frequency inverter. Actuators can be connected via the available digital outputs of the device. The following connections are each provided for four reference data bits:

BUS IN	Function (P480[-01...-04])	Status		Status
		Bit 1	Bit 0	
Bit 0	Enable right	0	0	Motor is switched off
Bit 1	Enable left	0	1	Right rotation field is present at the motor
Bit 2	Fixed frequency 2 (→ P465[-02])	1	0	Left rotation field is present at the motor
Bit 3	Acknowledge fault ¹⁾	1	1	Motor is switched off

1) Acknowledge with flank 0 → 1.

For control via the bus, acknowledgement is not automatically performed by a flank at one of the enable inputs

BUS OUT	Function (P481 [-01 ... -04])	Status		Status
		Bit 1	Bit 0	
Bit 0	Inverter ready	0	0	Error active
Bit 1	Warning	0	1	Warning
Bit 2 ¹⁾	Digital-In 1 status	1	0	Start disabled
Bit 3 ¹⁾	Digital-In 2 status	1	1	Standby / Run

1) Bits 2 and 3 are directly coupled to digital inputs 1 and 2

Parallel actuation via the BUS and the digital inputs is possible. The relevant inputs are dealt with more or less as normal digital inputs. If a changeover between manual and automatic is going to take place, it must be ensured that no enable via the normal digital inputs takes place in automatic mode. This could be implemented e.g. with a three-position key switch. Position 1: "Manual left" Position 2: "Automatic" Position 3: "Manual right".

If an enable is present via one of the two "normal" digital inputs, the control bits from the bus system are ignored. An exception is the control bit "Acknowledge fault". This function is always possible in parallel, regardless of the control hierarchy. The bus master can therefore only take over control if no actuation via a digital input takes place. If "Enable left" and "Enable right" are set simultaneously, the enable is removed and the motor stops without a deceleration ramp (block voltage).

4.5.4.4 Addressing

In order to use the device in an AS-i network, it must have a unique address. The address is set to 0 in the factory. This means that the device can be recognised as a "new device" by an AS-i master (prerequisite for automatic address assignment by the master).

Course of action

- Ensure power supply of the AS interface via the yellow AS interface cable.

- Disconnect the AS interface master during addressing
- Set the address $\neq 0$
- Do not doubly assign addresses

In many other cases, addressing is carried out using a normal addressing device for AS interface slaves (example follows).

- Pepperl+Fuchs, VBP-HH1-V3.0-V1 (separate M12 connection for external power supply)
- IFM, AC1154 (battery operated addressing device)

The options for addressing the AS Interface Slave with an addressing device in practice are listed in the following.

Version 1

Using an addressing device which is equipped with an **M12 connector** for connecting to the **AS-i bus**, you can incorporate yourself into the AS interface network via an appropriate access. The prerequisite for this is that the AS interface master can be switched off.

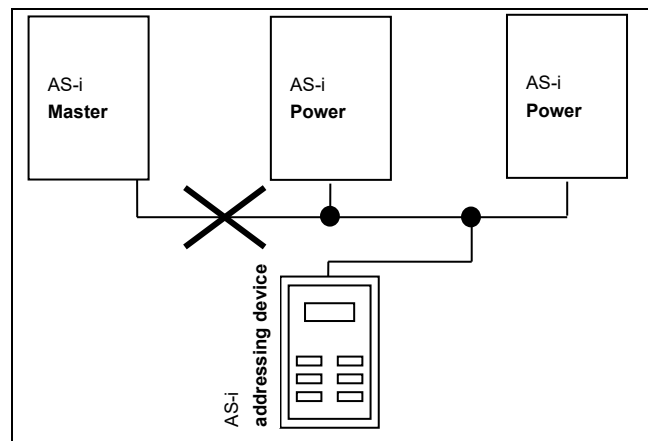

Version 2

With an addressing device that is equipped with an **M12 connector** for connecting to the **AS-i bus** and an additional **M12 connector** for connecting an external **voltage supply**, the addressing device can be directly incorporated in the AS-i cable.

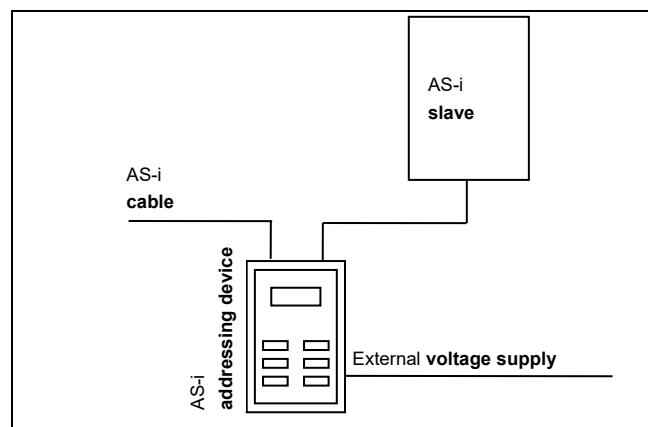

4.5.5 Certificate

Currently available certificates can be found on the Internet at [Link "www.nord.com"](http://www.nord.com)

5 Parameter

WARNING

Unexpected movement

Connection of the supply voltage may directly or indirectly set the device into motion. This can cause unexpected movement of the drive and the attached machine, which may result in serious or fatal injuries and/or material damage. Possible causes of unexpected movements are e.g.:

- Parameterisation of an “automatic start”
 - Incorrect parameterisation
 - Control of the device with an enabling signal from a higher level control system (via IO or bus signals)
 - Incorrect motor data
 - Incorrect encoder connection
 - Release of a mechanical holding brake
 - External influences such as gravity or other kinetic energy which acts on the drive unit
 - In IT networks: Mains fault (earth fault)
- To avoid any resulting hazard, the drive / drive chain must be secured against unexpected movements (mechanical blocking and/or decoupling, provision of protection against falling etc.) In addition, it must be ensured that there are no persons within the area of action and the danger area of the system.

WARNING

Unexpected movement due to changes in the parameterisation

Parameter changes become effective immediately. Under certain conditions, dangerous situations may occur, even when the drive is in standstill. Functions such as **P428** “Automatic starting” or **P420** “Digit inputs” or the “Brake off” setting can put the drive in motion and put persons at risk due to moving parts.

Therefore:

- Changes to parameter settings must only be made when the Frequency Inverter is not enabled.
- During parametrisation works, precautions must be taken to prevent unwanted drive movements (e.g. lifting equipment plunging down). The danger area of the system must not be entered.

WARNING

Unexpected movement due to overload

In case of overload of the drive, there is a risk that the motor will “break down” (sudden loss of torque). An overload may be caused e.g. by inadequate dimensioning of the drive unit or by the occurrence of sudden peak loads. Sudden peak loads may be of a mechanical origin (e.g. blockage) or may be caused by extremely steep acceleration ramps (P102, P103, P426).

Depending on the type of application, a “breakdown” of the motor may cause unexpected movement (e.g. dropping of loads by lifting equipment).

To prevent risk, the following must be observed:

- For lifting equipment applications or applications with frequent large load changes, parameter P219 must remain in the factory setting (100%).
- Do not inadequately dimension the drive unit, provide adequate overload reserves.
- If necessary, provide protection against falling (e.g. for lifting equipment) or equivalent protective measures.

The relevant parameters for the device are described in the following. The parameters are accessed using a parametrisation tool (e.g. NORDCON software or control and parametrisation unit, see also (📖 Section 3.1 "Control and parametrisation options ") and therefore makes it possible to adapt the device to the drive task in the best possible way. Different device configurations can result in dependencies for the relevant parameters.

The parameters can only be accessed if the control unit of the device is active.

The device is equipped with a power supply unit, which generates the required 24 V DC control voltage by applying the mains voltage (see 📖 Section 2.4.2 "Electrical connection of power unit").

Limited adjustments of individual functions on the respective devices can be made via DIP switches. Any further adjustment requires access to the device's parameters. **It must be noted that hardware configurations (DIP switches) have priority over software configurations (parameterisation).**

Each frequency inverter is preset at the factory for a NORD motor of the same power. All parameters can be adjusted "online". Four parameter sets are available, which are switchable during operation. The scope of the parameters to be displayed can be influenced via the supervisor parameter **P003**.

The relevant parameters for the device are described in the following. Explanations for parameters which concern the field bus options or special functions, for example, can be obtained from the respective supplementary manuals.

The individual parameters are functionally combined into groups. The first digit of the parameter number indicates the assignment to a **menu group**:

Menu group	No.	Master function
Operating displays	(P0--)	Display of parameters and operational values
Basic parameters	(P1--)	Basic device settings, e.g. on/off switching behaviour.
Motor data	(P2--)	Electrical settings for the motor (motor current or start voltage (start-off voltage))
PLC	(P3--)	Settings for the integrated PLC
Control terminals	(P4--)	Assignment of functions for the inputs and outputs
Extra parameters	(P5--)	Priority monitoring functions and other parameters
Information	(P7--)	Display of operating values and status messages

Information

Factory setting P523

The factory settings of the entire parameter set can be loaded at any time using parameter **P523**. For example, this can be useful during commissioning if it is not known which device parameters have been previously changed and could have an unexpected influence on the operating behaviour of the drive.

The restoration of the factory settings (**P523**) normally affects all parameters. This means that all motor data must subsequently be checked or reconfigured. However, parameter **P523** also provides a facility for excluding the motor data or the parameters relating to bus communication when the factory settings are restored.

It is advisable to back up the present settings of the frequency inverter beforehand.

5.1 Parameter overview

Operating displays

P000 Operating display	P001 Selection of display value	P002 Display factor
P003 Display factor		

Basic parameters

P100 Parameter set	P101 Copy parameter set	P102 Acceleration time
P103 Deceleration time	P104 Minimum frequency	P105 Maximum frequency
P106 Ramp smoothing	P107 Brake response time	P108 Disconnection mode
P109 DC brake current	P110 Time DC-brake on	P111 P-factor torque limit
P112 Torque current limit	P113 Jog frequency	P114 Brake release time
P120 Option monitoring		

Motor data

P200 Motor list	P201 Nominal frequency	P202 Nominal speed
P203 Nominal current	P204 Nominal voltage	P205 Nominal power
P206 Cos phi	P207 Star Delta con.	P208 Stator resistance
P209 No Load Current	P210 Static boost	P211 Dynamic boost
P212 Slip compensation	P213 ISD ctrl. loop gain	P214 Torque precontrol
P215 Boost precontrol	P216 Time boost prectrl.	P217 Oscillation damping
P218 Modulation depth	P219 Auto.magn.adjustment	P220 Par.-identification
P240 EMF voltage PMSM	P241 Inductivity PMSM	P243 Reluct. angle IPMSM
P244 Peak current PMSM	P245 Osc damping PMSM VFC	P247 Switch freq VFC PMSM

Speed control

P300 Servo mode		P310 Speed controller P
P311 Speed controller I	P312 Torque current controller P	P313 Torque current controller I
P314 Torque current control limit	P315 Field curr. ctrl. P	P316 Field curr. ctrl. I
P317 Field curr. ctrl. lim.	P318 Field weakening controller P	P319 Field weakening controller I
P320 Weak border		
P330 Rotor starting position detection	P350 PLC functionality	P351 PLC setpoint selection
P353 Bus status via PLC	P355 PLC integer setpoint	P356 PLC long setpoint
P360 PLC display value	P370 PLC status	

Control terminals

P400 Function Setpoint inputs	P401 Analogue input mode	P402 Adjustment: 0%
P403 Adjustment: 100%	P404 Analogue input filter	P410 Min. freq. Auxiliary setpoint
P411 Max. Freq. Auxiliary setpoint	P412 Nom. val. process ctrl.	P413 PI control P comp.
P414 PI control I comp.	P415 Limit process ctrl.	P416 Ramp time PI setpoint
P417 Offset analogue output	P418 Funct. analogue output	P419 Standard analogue output
P420 Digital inputs	P426 Quick stop time	P427 Emerg. stop Fault
P428 Automatic starting	P434 Digital output function	P435 Dig. out scaling
P436 Dig. out. hysteresis	P460 Watchdog time	P464 Fixed frequency mode
P465 Fixed freq. Array	P466 Minimum freq. process control	P475 delay on/off switch
P480 Function BusIO In Bits	P481 Function BusIO Out Bits	P482 Standard BusIO Out Bits
P483 Hyst. BusIO Out Bits		

Extra parameters

P501 Inverter name	P502 Master function value	P503 Leading function output
P504 Pulse frequency	P505 Absolute minimum freq.	P506 Auto. Fault acknowledgement
P509 Control word source	P510 Setpoint source	P511 USS baud rate
P512 USS address	P513 Telegram timeout	P514 CAN bus baud rate
P515 CAN bus address	P516 Skip frequency 1	P517 Skip freq. area 1
P518 Skip frequency 2	P519 Skip freq. area 2	P520 Flying start
P521 Flying start Resolution	P522 Flying start Offset	P523 Factory setting
P525 Load control max	P526 Load control min	P527 Load monitoring Freq.
P528 Load monitoring delay	P529 Mode Load control	P533 Factor I ² t
P534 Torque shutoff lim.	P535 I ² t motor	P536 Current limit
P537 Pulse disconnection	P539 Output monitoring	P540 Mode phase sequence
P541 Set relays	P542 Set analogue out	P543 Bus - Actual value
P546 Function Setpoint Bus value	P549 Pot Box function	
P552 CAN master cycle	P553 PLC setpoint	P555 P - limit chopper
P556 Braking resistor	P557 Braking resistor type	P558 Flux delay
P559 DC Run-on time	P560 Parameter, saving mode	

Information

P700 Present Operating status	P701 Last fault	P702 Freq. last error
P703 Current. last error	P704 Volt. last error	P705 Dc.lnk volt. last er.
P706 P set last error	P707 Software version	P708 Status of digital in.
P709 Analogue input voltage	P710 Analogue output volt.	P711 State of relays
P714 Operating time	P715 Running time	P716 Current frequency
P717 Current speed	P718 Present Setpoint frequency	P719 Actual current
P720 Present Torque current	P721 Actual field current	P722 Current voltage
P723 Voltage -d	P724 Voltage -q	P725 Current cos phi
P726 Apparent power	P727 Mechanical power	P728 Input voltage
P729 Torque	P730 Field	P731 Parameter set
P732 Phase U current	P733 Phase V current	P734 Phase W current
P735 Speed encoder	P736 DC link current	P737 Usage rate brake res.
P738 Usage rate motor	P739 Heatsink temperature	P740 Process data Bus In
P741 Process data Bus Out	P742 Data base version	P743 Inverter ID
P744 Configuration		P746 Option Status
P747 Inverter Volt. Range	P748 CANopen status	P749 Status of DIP switches
P750 Stat. Overcurrent	P751 Stat. Overvoltage	P752 Stat. Mains fault
P753 Stat. Overtemp.	P754 Stat. Param. loss	P755 Stat. System error
P756 Stat. Timeout	P757 Stat. Customer error	P760 Current mains current
P780 Device ID	P799 Op.-time last error	

5.2 Description of parameters

Pxxx	[-01]	xxxx	(xxxxxxx)	€	.E	S	P
①	②	③		④	⑤	⑥	
0 ... 36		[-01] = xx xxx,	xxxxxxx				
{ 1 }		[-02] = xx xxx,	xxxxxxx				
⑦		⑧					
⑨							

- 1 Parameter number
- 2 Array values
- 3 Parameter text; top: Display in ParameterBox, bottom: Meaning
- 4 Special features (e.g. only available in device model SK xxx)
- 5 (S) Parameter of type Supervisor, → depending on setting in **P003**
- 6 (P) Parameter, to which different values can be assigned depending on the selected parameter set (selection in **P100**)
- 7 Parameter value range
- 8 Description of parameters
- 9 Factory settings (default value) of parameter

5.2.1 Operating displays

Abbreviations used:

- **FI** = Frequency inverter
- **SW** = Software version, stored in P707.
- **S = Supervisor parameters** are visible or hidden depending on P003.

Parameter {factory setting}	Setting value / Description / Note		Supervisor	Parameter set
P000	Operating display (Operating parameter display)			
0.01 ... 9999	In ParameterBoxes with 7-segment displays (e.g. SimpleBox) the operating value which is selected in P001 is displayed <i>online</i> . Important information about the operating status of the drive can be read out as required.			
P001	Display selection (Display selection)			
0 ... 65 { 0 }	Selection of operating display of a parametrisation box with 7-segment display (e.g.: SimpleBox)			
	0 = Actual frequency [Hz] Currently supplied output frequency			
	1 = Speed [rpm] Calculated speed			
	2 = Target frequency [Hz] Output frequency that corresponds to the pending setpoint. This need not correspond with the current output frequency.			
	3 = Current [A] Current measured output current			
	4 = Actual torque current [A]: Torque-forming output current			
	5 = Voltage [V AC] Current alternating voltage present at the device output			
	6 = Link voltage [V DC] The <i>Link voltage [Vdc]</i> is the FI-internal DC voltage. Amongst other things, this depends on the level of the mains voltage.			
	7 = cos Phi Current calculated value of the power factor			
	8 = Apparent power [kVA] Calculated current apparent power			

9 =	Effective power [kW]	Calculated current effective power
10 =	Torque [%]	Calculated current torque
11 =	Field [%]	Calculated current field in motor
12 =	Hours of operation [h]	Time for which main voltage present at device
13 =	Operating time Enable [h]	" <i>Enabled operating hours</i> " is the time for which the device was enabled.
14 =	Analogue input 1 [%]	Current value that is present at analogue input 1 of the device
15 =	Analogue input 2 [%]	Current value that is present at analogue input 2 of the device
16 =	... 18	<i>Reserved</i>
19 =	Heat sink temperature [°C]	Current temperature of the heat sink
20 =	Actual utilisation of motor [%]	Average motor utilisation, based on the known motor data (P201...P209).
21 =	Brake resistor utilisation [%]	" <i>Braking resistor utilisation</i> " is the average braking resistor load, based on the known resistance data (P556...P557).
22 =	Interior temperature [°C]	Current interior temperature of device (SK 54xE / SK 2xxE)
23 =	Motor temperature	Measured via KTY-84
24 =	... 29	<i>Reserved</i>
30 =	Present Target MP-S [Hz]	" <i>Current motor potentiometer function setpoint with storage</i> ". (P420...=71/72). The nominal value can be read out with this function or pre-set (without the drive running).
31 =	... 39	<i>Reserved</i>
40 =	PLC control box value	Visualisation mode for PLC communication
41 =	... 59	<i>Reserved</i>
60 =	R stator ident	Stator resistance determined by means of measurement (P220)
61 =	R rotor ident	the rotor resistance determined by measurement ((P220) Function 2)
62 =	L stray stator ident	the stray inductance determined by measurement ((P220) Function 2)
63 =	L stator ident	the inductance determined by measurement ((P220) Function 2)
65 =		<i>Reserved</i>

P002	Display factor (<i>Display factor</i>)		S	
0.01 ... 999.99 { 1.00 }	The selected operating value in parameter P001 >Select of display< is multiplied with the scaling factor in P000 and displayed in >Operating parameter display<. It is therefore possible to display system-specific operating such as e.g. the throughput quantity			
P003	Supervisor code (<i>Supervisor code</i>)			
0 ... 9999 { 1 }	0 = The supervisor parameters and groups P3xx/P6xx are not visible, otherwise all. 1 = All parameters are visible, except groups P3xx and P6xx. 2 = All parameters are visible, except group P6xx. 3 = All parameters are visible. 4 = ... 9999, only parameters P001 and P003 are visible.			
 Information		Display via NORDCON		
If parameterisation is carried out with the NORDCON software, the settings 4 ... 9999 the settings are as for the 0 setting. Settings 1 and 2 behave like setting 3.				

5.2.2 Basic parameters

Parameter {factory setting}	Setting value / Description / Note		Supervisor	Parameter set
P100	Parameter set (Parameter set)		S	
0 ... 3 { 0 }	<p>Selection of the parameters sets to be parameterised. 4 parameter sets are available. The parameters to which different values can also be assigned in the 4 parameter sets are known as "parameter set-dependent" and are marked with a "P" in the header in the following descriptions.</p> <p>The operating parameter set is selected using appropriately parametrised digital inputs or by means of BUS actuation.</p> <p>If enabled via the keyboard (SimpleBox, ControlBox, PotentiometerBox or ParameterBox), the operating parameter set will match the settings in P100.</p>			
P101	Copy parameter set (Copy parameter set)		S	
0 ... 4 { 0 }	<p>After confirmation with the OK / ENTER key, a copy of the parameter set selected in P100 >Parameter set< is written to the parameter set dependent on the value selected here</p> <p>0 = Do not copy</p> <p>1 = Copy actual to P1: Copies the active parameter set to parameter set 1</p> <p>2 = Copy actual to P2: Copies the active parameter set to parameter set 2</p> <p>3 = Copy actual to P3: Copies the active parameter set to parameter set 3</p> <p>4 = Copy actual to P4: Copies the active parameter set to parameter set 4</p>			
P102	Acceleration time (Acceleration time)			P
0 ... 320.00 sec { 2.00 }	<p>The start-up time is the time corresponding to the linear frequency rise from 0 Hz to the set maximum frequency (P105). If an actual setpoint of <100 % is being used, the acceleration time is reduced linearly according to the setpoint which is set.</p> <p>The acceleration time can be extended by certain circumstances, e.g. FI overload, setpoint lag, smoothing, or if the current limit is reached.</p> <p>NOTE:</p> <p>Care must be taken that the parameter values are realistic. A setting of P102 = 0 is not permissible for drive units!</p> <p>Notes on ramp gradient:</p> <p>Amongst other things, the ramp gradient is governed by the inertia of the rotor.</p> <p>A ramp with a gradient which is too steep may result in the "inversion" of the motor.</p> <p>In general, extremely steep ramps (e.g.: 0 - 50 Hz in < 0.1 s) should be avoided, as may cause damage to the frequency inverter.</p>			
P103	Braking time (Braking time)			P
0 ... 320.00 sec { 2.00 }	<p>The braking time is the time corresponding to the linear frequency reduction from the set maximum frequency to 0 Hz (P105). If an actual setpoint <100 % is being used, the deceleration time reduces accordingly.</p> <p>The braking time can be extended by certain circumstances, e.g. by the selected >Switch-off mode< (P108) or >Ramp smoothing< (P106).</p> <p>NOTE:</p> <p>Care must be taken that the parameter values are realistic. A setting of P103 = 0 is not permissible for drive units!</p> <p>Notes concerning ramp steepness: see parameter (P102)</p>			

P104	Minimum frequency <i>(Minimum frequency)</i>			P
0.0 ... 400.0 Hz { 0.0 }	<p>The minimum frequency is the frequency supplied by the FI as soon as it is enabled and no additional setpoint is set.</p> <p>In combination with other setpoints (e.g. analog setpoint of fixed frequencies) these are added to the set minimum frequency.</p> <p>This frequency is undershot when</p> <ol style="list-style-type: none"> the drive is accelerated from standstill. The FI is blocked. The frequency then reduces to the absolute minimum (P505) before it is blocked. The FI reverses. The reverse in the rotation field takes place at the absolute minimum frequency (P505). <p>This frequency can be continuously undershot if, during acceleration or braking, the function "Maintain frequency" (Function Digital input = 9) is executed.</p>			
P105	Maximum frequency <i>(Maximum frequency)</i>			P
0.1 ... 400.0 Hz { 50.0 }	<p>The frequency supplied by the FI after being enabled and once the maximum setpoint is present; e.g. analogue setpoint according to P403, a correspondingly fixed frequency or maximum via SimpleBox/ParameterBox.</p> <p>This frequency can only be exceeded by the slip compensation (P212), the function "Maintain the freq." (Digital input function = 9) or the switch to another parameter set with lower maximum frequency.</p> <p>Maximum frequencies are subject to certain restrictions, e.g.</p> <ul style="list-style-type: none"> Restrictions in weak field operation, Compliance with mechanically permissible speeds, PMSM: Restriction of the maximum frequency to a value which is slightly above the nominal frequency. This value is calculated from the motor data and the input voltage. 			

P106	Ramp smoothing (Ramp smoothing)			P
-------------	---	--	--	----------

0 ... 100 %
{ 0 }

This parameter enables a smoothing of the acceleration and deceleration ramps. This is necessary for applications where gentle, but dynamic speed change is important.
Ramp smoothing is carried out for every setpoint change.
The value to be set is based on the set acceleration and deceleration time, however values <10% have no effect.
The following then applies for the entire acceleration or deceleration time, including rounding:

$$t_{\text{tot ACCELERATION TIME}} = t_{P102} + t_{P102} \cdot \frac{P106 [\%]}{100\%}$$

$$t_{\text{tot DECELERATION TIME}} = t_{P103} + t_{P103} \cdot \frac{P106 [\%]}{100\%}$$

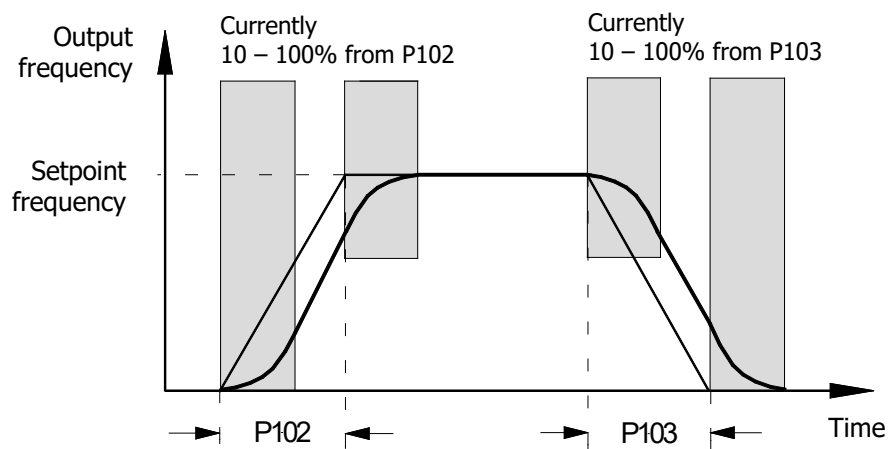

Note: Under the following conditions ramp rounding is switched off or replaced with a linear ramp with extended times:

- Acceleration values (+/-) less than 1 Hz/s
- Acceleration values (+/-) greater than 1 Hz/ms
- Rounding values less than 10 %

P107	Brake reaction time (Brake reaction time)			P
-------------	---	--	--	----------

0 ... 2.50 s
{ 0.00 }

Electromagnetic brakes have a physically-dependent delayed reaction time when actuated. This can cause a dropping of the load for lifting applications, as the brake only takes over the load after a delay.
The reaction time must be taken into consideration by setting parameter P107.
Within the adjustable application time, the FI supplies the set absolute minimum frequency (P505) and so prevents movement against the brake and load drop when stopping.
If a time > 0 is set in P107 or P114, at the moment the FI is switched on, the level of the excitation current (field current) is checked. If no magnetising current is present, the FI remains in magnetising mode and the motor brake is not released.
In order to achieve a shut-down and an error message (E016) in this case, P539 must be set to 2 or 3.
See also the parameter >Release time< P114

Recommended parameterisation for the application:
Lifting gear with brake without speed feedback

- P114** = 0.02 ... 0.4 s *
- P107** = 0.02 ... 0.4 s *
- P201 ... P208** = Motor data
- P434** = 1 (ext. brake)
- P505** = 2 ... 4 Hz

For safe starting

- P112** = "Off"
- P536** = "Off"
- P537** = Factory setting
- P539** = Check of exciting current

Against load drops

- P214** = 50 ... 100% (precontrol)

* Setting values (**P107/P114**) depend on braking type and motor size. For low powers (< 1.5 kW), smaller values apply; for higher powers (> 4.0 kW), larger values apply.

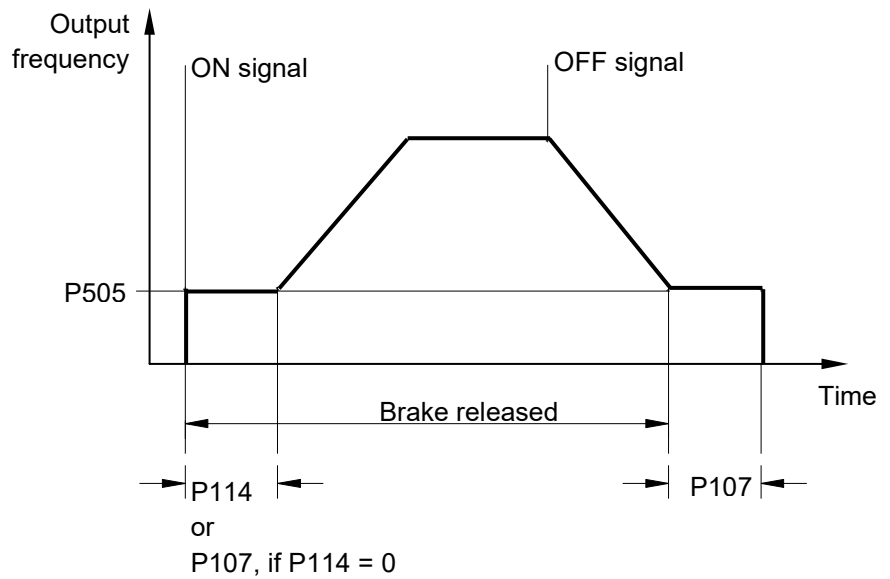

Information

Brake control





To control the electromechanical brake (especially for lifting gears), the relevant connection on the frequency inverter must be used, if available. The absolute minimum frequency (**P505**) should never be less than 2.0 Hz.



P108	Disconnection mode (Disconnection mode)		S	P
0 ... 13 { 1 }	This parameter determines the manner in which the output frequency is reduced after "Blocking" (controller enable → Low).			
	<p>0 = Block voltage: The output signal is switched off immediately. The FI no longer supplies an output frequency. The motor is only braked by mechanical friction. Switching the FI on again immediately can lead to an error message.</p> <p>1 = Ramp: The current output frequency is reduced in proportion to the remaining deceleration time, from P103/P105. The DC run-on follows the end of the ramp (→ P559).</p> <p>2 = Ramp with delay: as for 1 "Ramp", however for generational operation the brake ramp is extended, or for static operation the output frequency is increased. Under certain conditions, this function can prevent overload switch off or reduce brake resistance power dissipation.</p> <p>NOTE: This function must not be programmed if defined deceleration is required, e.g. with lifting mechanisms.</p> <p>3 = Immediate DC braking: The FI switches immediately to the preselected DC current (P109). This DC current is supplied for the remaining proportion of the >DC brake time< (P110). Depending on the relationship, actual output frequency to max. frequency (P105), the >Time DC brake on< is shortened. The time taken for the motor to stop depends on the application. The time taken to stop depends on the mass inertia of the load and the DC current set (P109). With this type of braking, no energy is returned to the FI; heat loss occurs mainly in the motor rotor.</p> <p>Not for PMSM motors!</p> <p>4 = Const. brake distance, "Constant brake distance": The brake ramp is delayed in starting if the equipment is <u>not</u> being driven at the maximum output frequency (P105). This results in an approximately similar braking distance for different frequencies.</p> <p>NOTE: This function cannot be used as a positioning function. This function should not be combined with ramp smoothing (P106).</p> <p>5 = Combined braking, "Combined braking": Dependent on the actual link voltage (UZW), a high frequency voltage is switched to the basic frequency (only for linear characteristic curves, P211 = 0 and P212 = 0). The braking time (P103) is complied with if possible. → Additional heating in the motor!</p> <p>Not for PMSM motors!</p> <p>6 = Quadratic ramp: The brake ramp does not follow a linear path, but rather a decreasing quadratic one.</p> <p>7 = Quad. ramp with delay, "Quadratic ramp with delay": Combination of functions 2 and 6</p> <p>8 = Quad. comb. braking, "Quadratic combined braking": Combination of functions 5 and 6</p> <p>Not for PMSM motors!</p> <p>9 = Const. acceln. power, "Constant acceleration power": Only applies in field weakening range! The drive is accelerated or braked using constant electrical power. The course of the ramps depends on the load.</p> <p>10 = Distance calculator: Constant distance between actual frequency / speed and the set minimum output frequency (P104).</p> <p>11 = Const. acceln. power with delay, "Constant acceleration power with delay": Combination of functions 2 and 9.</p> <p>12 = Const. acceln. power mode 3, "Constant acceleration power mode 3" as for 11, however with additional relief of the brake chopper</p> <p>13 = Disconnection delay, "Ramp with disconnection delay": as for 1 "Ramp", however, before the brake is applied, the drive unit remains at the absolute minimum frequency set in parameter (P505) for the time specified in parameter (P110). Application example: Re-positioning for crane control</p>			

P109	DC brake current (DC brake current)		S	P
0 ... 250 % { 100 }	<p>Current setting for the functions of DC current braking (P108 = 3) and combined braking (P108 = 5).</p> <p>The correct setting value depends on the mechanical load and the required deceleration time. A higher setting brings large loads to a standstill more quickly.</p> <p>The 100% setting relates to a current value as stored in the >Nominal current< parameter P203.</p> <p>NOTE: The amount of DC current (0 Hz) which the FI can supply is limited. For this value, please refer to the table in Section 8.4 "Reduced output power", column: 0 Hz. In the basic setting this limiting value is about 110 %.</p> <p>DC braking Not for PMSM motors!</p>			
P110	Time DC-brake on (DC braking time on)		S	P
0.00 ... 60.00 sec { 2.00 }	<p>The time during which current selected in parameter P109 is applied to the motor for the function "DC braking" selected in parameter P108 (P108 = 3).</p> <p>Depending on the relationship of the actual output frequency to the max. frequency (P105), the >DC brake time< is shortened.</p> <p>The time starts running with the removal of the enable and can be interrupted by fresh enabling.</p> <p>DC braking Not for PMSM motors!</p>			
P111	P factor torque limit (P factor torque limit)		S	P
25 ... 400 % { 100 }	<p>Directly affects the behaviour of the drive at torque limit. The basic setting of 100% is sufficient for most drive tasks.</p> <p>If values are too high the drive tends to vibrate as it reaches the torque limit. If values are too low, the programmed torque limit can be exceeded.</p>			
P112	Torque current limit (torque current limit)		S	P
25 ... 400 % / 401 { 401 }	<p>With this parameter, a limit value for the torque-generating current can be set. This can prevent mechanical overloading of the drive. It cannot provide any protection against mechanical blockages (movement to stops). A slipping clutch which acts as a safety device must be provided.</p> <p>The torque current limit can also be set over an infinite range of settings using an analogue input. The maximum setpoint (see 100% calibration, P403[-01] . [-06]) the corresponds to the setting in P112.</p> <p>The limit value 20% of current torque cannot be undershot by a smaller analogue setpoint (P400[-01] ... [-09] = 11 or 12). In contrast, in servo mode ((P300) = "1") as of firmware version V 1.3 a limiting value of 0% is possible (older firmware versions: min. 10%)!</p> <p>401 = OFF means the switch-off of the torque current limit! This is also the basic setting for the FI.</p>			
P113	Jog frequency (Jog frequency)		S	P
-400.0 ... 400.0 Hz { 0.0 }	<p>When using the SimpleBox or ParameterBox to control the FI, the jog frequency is the initial value following successful enabling.</p> <p>Alternatively, when control is via the control terminals, the jog frequency can be activated via one of the digital inputs.</p> <p>The setting of the jog frequency can be done directly via this parameter or, if the FI is enabled via the keyboard, by pressing the OK key. In this case, the actual output frequency is set in parameter P113 and is then available for the next start.</p> <p>NOTE: Specified setpoints via the control terminals, e.g. jog frequency, fixed frequencies or analogue setpoints, are generally added with the correct sign. The set maximum frequency (P105) cannot be exceeded and the minimum frequency (P104) cannot be undershot.</p>			

5.2.3 Motor data / Characteristic curve parameters

Parameter {factory setting}	Setting value / Description / Note		Supervisor	Parameter set																																																																															
P200	Motor list (Motor list)			P																																																																															
0 ... 73 { 0 }	<p>The factory settings for the motor data can be edited with this parameter. A 4-pole IE1 three-phase standard motor with the FI nominal power is factory-set in parameters P201 ... P209. By selecting one of the possible digits and pressing the ENTER key, all of the motor parameters (P201 ... P209) are matched to the selected motor power. The motor data is based on a 4-pole three-phase standard motor.</p> <p>Note: As P200 is = 0 again after input acknowledgement, the set motor can be controlled via parameter P205.</p> <div style="border: 1px solid black; padding: 5px; margin: 10px 0;"> <p style="text-align: center;">i Information</p> <p>If IE2/IE3 motors are used, after selecting an IE1 motor (P200), the motor data in P201 ... P209 must be adapted to the data on the motor name plate.</p> </div> <p>0 = No change</p> <p>1 = No motor: In this setting, the FI operates without current control, slip compensation and pre-magnetising time, and is therefore not recommended for motor applications. Possible applications are induction furnaces or other applications with coils and transformers. The following motor data is set here: 50.0 Hz / 1500 rpm / 15.0 A / 400 V / 0.00 kW / cos φ=0.90 / Stern / R_s 0.01 Ω / I_{LEER} 6.5 A</p> <table style="width: 100%; border-collapse: collapse;"> <tr> <td style="width: 25%;">2 = 0.12kW 230V</td> <td style="width: 25%;">19 = 1.0 PS 230V</td> <td style="width: 25%;">36 = 3.0 kW 400V</td> <td style="width: 25%;">52 = 0.75kW 230V 80T1/4</td> </tr> <tr> <td>3 = 0.16PS 230V</td> <td>20 = 0.75kW 400V</td> <td>37 = 4.0 PS 460V</td> <td>53 = 1.10kW 230V 90T1/4</td> </tr> <tr> <td>4 = 0.18kW 400V</td> <td>21 = 1.0 PS 460V</td> <td>38 = 4.0 kW 230V</td> <td>54 = 1.10kW 230V 80T1/4</td> </tr> <tr> <td>5 = 0.25PS 460V</td> <td>22 = 1.1 kW 230V</td> <td>39 = 5.0 PS 230V</td> <td>55 = 1.10kW 400V 80T1/4</td> </tr> <tr> <td>6 = 0.25kW 230V</td> <td>23 = 1.5 PS 230V</td> <td>40 = 4.0 kW 400V</td> <td>56 = 1.50kW 230V 90T3/4</td> </tr> <tr> <td>7 = 0.33PS 230V</td> <td>24 = 1.1 kW 400V</td> <td>41 = 5.0 PS 460V</td> <td>57 = 1.50kW 230V 90T1/4</td> </tr> <tr> <td>8 = 0.25kW 400V</td> <td>25 = 1.5 PS 460V</td> <td>42 = 5.5 kW 230V</td> <td>58 = 1.50kW 400V 90T1/4</td> </tr> <tr> <td>9 = 0.33PS 460V</td> <td>26 = 1.5 kW 230V</td> <td>43 = 7.5 PS 230V</td> <td>59 = 1.50kW 400V 80T1/4</td> </tr> <tr> <td>10 = 0.37kW 230V</td> <td>27 = 2.0 PS 230V</td> <td>44 = 5.5 kW 400V</td> <td>60 = 2.20kW 230V 100T2/4</td> </tr> <tr> <td>11 = 0.50PS 230V</td> <td>28 = 1.5 kW 400V</td> <td>45 = 7.5 PS 460V</td> <td>61 = 2.20kW 230V 90T3/4</td> </tr> <tr> <td>12 = 0.37kW 400V</td> <td>29 = 2.0 PS 460V</td> <td>46 = 7.5 kW 230V</td> <td>62 = 2.20kW 400V 90T3/4</td> </tr> <tr> <td>13 = 0.50PS 460V</td> <td>30 = 2.2 kW 230V</td> <td>47 = 10.0 PS 230V</td> <td>63 = 2.20kW 400V 90T1/4</td> </tr> <tr> <td>14 = 0.55kW 230V</td> <td>31 = 3.0 PS 230V</td> <td>48 = 7.5 kW 400V</td> <td>64 = 3.00kW 230V 100T5/4</td> </tr> <tr> <td>15 = 0.75PS 230V</td> <td>32 = 2.2 kW 400V</td> <td>49 = 10.0 PS 460V</td> <td>65 = 3.00kW 230V 100T2/4</td> </tr> <tr> <td>16 = 0.55kW 400V</td> <td>33 = 3.0 PS 460V</td> <td>50 = 11.0 kW 400V</td> <td>66 = 3.00kW 400V 100T2/4</td> </tr> <tr> <td>17 = 0.75PS 460V</td> <td>34 = 3.0 kW 230V</td> <td>51 = 15.0 PS 460V</td> <td>67 = 3.00kW 400V 90T3/4</td> </tr> <tr> <td>18 = 0.75kW 230V</td> <td>35 = 4.0 PS 230V</td> <td></td> <td>68 = 4.00kW 230V 100T5/4</td> </tr> <tr> <td></td> <td></td> <td></td> <td>69 = 4.00kW 400V 100T5/4</td> </tr> <tr> <td></td> <td></td> <td></td> <td>70 = 4.00kW 400V 100T2/4</td> </tr> <tr> <td></td> <td></td> <td></td> <td>71 = 5.50kW 400V 100T5/4</td> </tr> </table>	2 = 0.12kW 230V	19 = 1.0 PS 230V	36 = 3.0 kW 400V	52 = 0.75kW 230V 80T1/4	3 = 0.16PS 230V	20 = 0.75kW 400V	37 = 4.0 PS 460V	53 = 1.10kW 230V 90T1/4	4 = 0.18kW 400V	21 = 1.0 PS 460V	38 = 4.0 kW 230V	54 = 1.10kW 230V 80T1/4	5 = 0.25PS 460V	22 = 1.1 kW 230V	39 = 5.0 PS 230V	55 = 1.10kW 400V 80T1/4	6 = 0.25kW 230V	23 = 1.5 PS 230V	40 = 4.0 kW 400V	56 = 1.50kW 230V 90T3/4	7 = 0.33PS 230V	24 = 1.1 kW 400V	41 = 5.0 PS 460V	57 = 1.50kW 230V 90T1/4	8 = 0.25kW 400V	25 = 1.5 PS 460V	42 = 5.5 kW 230V	58 = 1.50kW 400V 90T1/4	9 = 0.33PS 460V	26 = 1.5 kW 230V	43 = 7.5 PS 230V	59 = 1.50kW 400V 80T1/4	10 = 0.37kW 230V	27 = 2.0 PS 230V	44 = 5.5 kW 400V	60 = 2.20kW 230V 100T2/4	11 = 0.50PS 230V	28 = 1.5 kW 400V	45 = 7.5 PS 460V	61 = 2.20kW 230V 90T3/4	12 = 0.37kW 400V	29 = 2.0 PS 460V	46 = 7.5 kW 230V	62 = 2.20kW 400V 90T3/4	13 = 0.50PS 460V	30 = 2.2 kW 230V	47 = 10.0 PS 230V	63 = 2.20kW 400V 90T1/4	14 = 0.55kW 230V	31 = 3.0 PS 230V	48 = 7.5 kW 400V	64 = 3.00kW 230V 100T5/4	15 = 0.75PS 230V	32 = 2.2 kW 400V	49 = 10.0 PS 460V	65 = 3.00kW 230V 100T2/4	16 = 0.55kW 400V	33 = 3.0 PS 460V	50 = 11.0 kW 400V	66 = 3.00kW 400V 100T2/4	17 = 0.75PS 460V	34 = 3.0 kW 230V	51 = 15.0 PS 460V	67 = 3.00kW 400V 90T3/4	18 = 0.75kW 230V	35 = 4.0 PS 230V		68 = 4.00kW 230V 100T5/4				69 = 4.00kW 400V 100T5/4				70 = 4.00kW 400V 100T2/4				71 = 5.50kW 400V 100T5/4		
2 = 0.12kW 230V	19 = 1.0 PS 230V	36 = 3.0 kW 400V	52 = 0.75kW 230V 80T1/4																																																																																
3 = 0.16PS 230V	20 = 0.75kW 400V	37 = 4.0 PS 460V	53 = 1.10kW 230V 90T1/4																																																																																
4 = 0.18kW 400V	21 = 1.0 PS 460V	38 = 4.0 kW 230V	54 = 1.10kW 230V 80T1/4																																																																																
5 = 0.25PS 460V	22 = 1.1 kW 230V	39 = 5.0 PS 230V	55 = 1.10kW 400V 80T1/4																																																																																
6 = 0.25kW 230V	23 = 1.5 PS 230V	40 = 4.0 kW 400V	56 = 1.50kW 230V 90T3/4																																																																																
7 = 0.33PS 230V	24 = 1.1 kW 400V	41 = 5.0 PS 460V	57 = 1.50kW 230V 90T1/4																																																																																
8 = 0.25kW 400V	25 = 1.5 PS 460V	42 = 5.5 kW 230V	58 = 1.50kW 400V 90T1/4																																																																																
9 = 0.33PS 460V	26 = 1.5 kW 230V	43 = 7.5 PS 230V	59 = 1.50kW 400V 80T1/4																																																																																
10 = 0.37kW 230V	27 = 2.0 PS 230V	44 = 5.5 kW 400V	60 = 2.20kW 230V 100T2/4																																																																																
11 = 0.50PS 230V	28 = 1.5 kW 400V	45 = 7.5 PS 460V	61 = 2.20kW 230V 90T3/4																																																																																
12 = 0.37kW 400V	29 = 2.0 PS 460V	46 = 7.5 kW 230V	62 = 2.20kW 400V 90T3/4																																																																																
13 = 0.50PS 460V	30 = 2.2 kW 230V	47 = 10.0 PS 230V	63 = 2.20kW 400V 90T1/4																																																																																
14 = 0.55kW 230V	31 = 3.0 PS 230V	48 = 7.5 kW 400V	64 = 3.00kW 230V 100T5/4																																																																																
15 = 0.75PS 230V	32 = 2.2 kW 400V	49 = 10.0 PS 460V	65 = 3.00kW 230V 100T2/4																																																																																
16 = 0.55kW 400V	33 = 3.0 PS 460V	50 = 11.0 kW 400V	66 = 3.00kW 400V 100T2/4																																																																																
17 = 0.75PS 460V	34 = 3.0 kW 230V	51 = 15.0 PS 460V	67 = 3.00kW 400V 90T3/4																																																																																
18 = 0.75kW 230V	35 = 4.0 PS 230V		68 = 4.00kW 230V 100T5/4																																																																																
			69 = 4.00kW 400V 100T5/4																																																																																
			70 = 4.00kW 400V 100T2/4																																																																																
			71 = 5.50kW 400V 100T5/4																																																																																
P201	Nominal frequency (Nominal frequency)		S	P																																																																															
10.0 ... 399.9 Hz { see information }	The motor frequency determines the V/f break point at which the FI supplies the nominal voltage (P204) at the output.																																																																																		
	<div style="border: 1px solid black; padding: 5px; margin: 10px 0;"> <p style="text-align: center;">i Information</p> <p>Default setting The default setting depends on the nominal power of the FI and the setting in P200.</p> </div>																																																																																		

P202	Nominal speed (Nominal speed)		S	P
150 ... 24000 rpm { see information }	The nominal motor speed is important for correct calculation and control of the motor slip and the speed display (P001 = 1).			
 Information				
Default setting The default setting depends on the nominal power of the FI and the setting in P200 .				
P203	Nominal current (Nominal current)		S	P
0.1 ... 1000.0 A { see information }	The nominal motor current is a decisive parameter for current vector control.			
 Information				
Default setting The default setting depends on the nominal power of the FI and the setting in P200 .				
P204	Nominal voltage (Nominal voltage)		S	P
100 ... 800 V { see information }	This parameter sets the nominal voltage. The combination with the nominal frequency results in the voltage/frequency characteristic curve.			
 Information				
Default setting The default setting depends on the nominal power of the FI and the setting in P200 .				
P205	Nominal power (Nominal power)			P
0.00 ... 250.00 kW { see information }	The motor nominal power controls the motor set via P200 .			
 Information				
Default setting The default setting depends on the nominal power of the FI and the setting in P200 .				
P206	Cos phi (Cos φ)		S	P
0.50 ... 0.98 { see information }	The motor cos φ is a decisive parameter for current vector control.			
 Information				
Default setting The default setting depends on the nominal power of the FI and the setting in P200 .				

P207	Star Delta con. (Star Delta con.)		S	P
0 ... 1 { see information }	0 = Star 1 = Delta The motor circuit is decisive for stator resistance measurement (P220) and therefore for current vector control.			
 Information				
Default setting The default setting depends on the nominal power of the FI and the setting in P200 .				
P208	Stator resistance (Stator resistance)		S	P
0.00 ... 300.00 Ω { see information }	Motor stator resistance ⇒ Resistance of a phase winding with a three-phase motor. Has a direct influence on the current control of the FI. A value which is too high may result in overcurrent; a value which is too low may result in low motor torque. Parameter P220 can be used for simple measurement. Parameter P208 can be used for manual setting or as information on the automatic measurement result. Note: For optimum functioning of the current vector control, the stator resistance must be measured automatically by the FI.			
 Information				
Default setting The default setting depends on the nominal power of the FI and the setting in P200 .				
P209	No-load current (No-load current)		S	P
0.0 ... 1000.0 A { see information }	This value is always calculated automatically from the motor data if there is a change in the parameter P206 “cos φ” and parameter P203 “Nominal current”. Note: If the value is to be entered directly, then it must be set as the last value of the motor data. This is the only way to ensure that the value will not be overwritten.			
 Information				
Default setting The default setting depends on the nominal power of the FI and the setting in P200 .				
P210	Static boost (Static boost)		S	P
0 ... 400% { 100 }	The static boost affects the current, which generates the magnetic field. This corresponds to the no-load current of the respective motor and therefore does not depend on the load. The no-load current is calculated using the motor data. The 100% factory setting is sufficient for typical applications.			

P211	Dynamic boost (<i>Dynamic boost</i>)		S	P
0 ... 150 % { 100 }	<p>The dynamic boost affects the torque generating current and is therefore a load-dependent parameter. The factory 100% setting is also sufficient for typical applications.</p> <p>Too high a value can lead to overcurrent in the FI. Under load therefore, the output voltage will be raised too sharply. Too low a value will lead to insufficient torque.</p>			
i Information		U/f – characteristic curve		
<p>For certain applications, particularly those with high centrifugal masses (e.g. fan drives) it may be necessary to control the motor using a U/f characteristic curve. For this, parameters P211 and P212 must each be set to 0%.</p>				
P212	Slip compensation (<i>Slip compensation</i>)		S	P
0 ... 150% { 100 }	<p>The slip compensation increases the output frequency, dependent on load, to keep the asynchronous motor speed approximately constant.</p> <p>The factory setting of 100% is optimal when using DC asynchronous motors and correct motor data has been set.</p> <p>If several motors (different loads or outputs) are operated with one FI, the slip compensation P212 must be set to 0%. This excludes any negative influences. With PMSM motors, the parameter must be left at the factory setting.</p>			
i Information		U/f – characteristic curve		
<p>For certain applications, particularly those with high centrifugal masses (e.g. fan drives) it may be necessary to control the motor using a U/f characteristic curve. For this, parameters P211 and P212 must each be set to 0%.</p>				
i Information		PMSM		
<p>When controlling a PMSM, this parameter determines the voltage of the test signal principal (P330). The required voltage depends on various factors (ambient and motor temperature, motor size, motor cable length, size of frequency inverter and others). If the rotor position identification is not successful, this parameter can be used to adjust the voltage.</p>				
P213	ISD ctrl. loop gain (<i>Amplification of ISD control</i>)		S	P
25 ... 400 % { 100 }	<p>This parameter influences the control dynamics of the FI current vector control (ISD control). Higher settings make the controller faster, lower settings slower.</p> <p>Dependent on application type, this parameter can be altered, e.g. to avoid unstable operation.</p>			
P214	Torque precontrol (<i>Torque precontrol</i>)		S	P
-200 ... 200 % { 0 }	<p>This function allows a value for the expected torque requirement to be set in the controller. This function can be used in lifting applications for a better load transfer during start-up.</p> <p>NOTE: Motor torques (with rotation field right) are entered with a positive sign, generator torques are entered with a negative sign. The reverse applies for the counter clockwise rotation.</p>			

P215	Boost precontrol (Boost precontrol)		S	P
0 ... 200 % { 0 }	<p>Only advisable with linear characteristic curve (P211 = 0% and P212 = 0%).</p> <p>For drives that require a high starting torque, this parameter provides an option for switching in an additional current during the start phase. The application time is limited and can be selected at parameter >Time boost precontrol< P216.</p> <p>All current and torque current limits that may have been set (P112 and P536, P537) are deactivated during the boost lead time.</p> <p>NOTE:</p> <p>With active ISD control (P211 and / or P212 ≠ 0%), parameterisation of P215 ≠ 0 results in incorrect control.</p>			
P216	Time boost precontrol (Time boost precontrol)		S	P
0.0 ... 10.0 sec { 0.0 }	<p>This parameter is used for 3 functionalities</p> <p>Time limit for the boost lead: Application time for increased starting current. Only with linear characteristic curve (P211 = 0% and P212 = 0%).</p> <p>Time limit for suppression of pulse switch-off (P537): enables start-up under heavy load.</p> <p>Time limit for suppression of switch-off on error in parameter (P401), setting { 05 } "0 - 10V with switch-off on error 2"</p>			
P217	Oscillation damping (Oscillation damping)		S	P
0 ... 400 % { 10 }	<p>With the oscillation damping, idling current harmonics can be damped. Parameter 217 is a measure of the damping power.</p> <p>For oscillation damping the oscillation component is filtered out of the torque current by means of a high pass filter. This is amplified by P217, inverted and switched to the output frequency.</p> <p>The limit for the value switched is also proportional to P217. The time constant for the high pass filter depends on P213. For higher values of P213 the time constant is lower.</p> <p>With a set value of 10 % for P217, a maximum of ± 0.045 Hz are switched in. At 400 % in P217, this corresponds to ± 1.8 Hz</p> <p>The function is not active in "Servo mode, P300".</p>			
P218	Modulation depth (Modulation depth)		S	
50 ... 110 % { 100 }e	<p>This setting influences the maximum possible output voltage of the FI in relation to the mains voltage. Values <100% reduce the voltage to values below that of the mains voltage if this is required for motors. Values >100% increase the output voltage to the motor increased the harmonics in the current, which may cause swinging in some motors.</p> <p>Normally, 100% should be set.</p>			

P219	Automatic flux optimisation <i>(Automatic flux optimisation)</i>		S	
25 ... 100 % / 101 { 100 }	<p>With this parameter, the magnetic flux of the motor can be automatically matched to the motor load, so that the energy consumption is reduced to the amount which is actually required. P219 is a limiting value, to which the field in the motor can be reduced.</p> <p>As standard, the value is set to 100 %, and therefore no reduction is possible. As minimum, 25 % can be set.</p> <p>The reduction of the field is performed with a time constant of approx. 7.5 s. On increase of load the field is built up again with a time constant of approx. 300 ms. The reduction of the field is carried out so that the magnetisation current and the torque current are approximately equal, so that the motor is operated with "optimum efficiency". An increase of the field above the setpoint value is not intended. This function is intended for applications in which the required torque only changes slowly (e.g. pumps and fans). Its effect therefore replaces a quadratic curve, as it adapts the voltage to the load.</p> <p>This parameter does not function for the operation of synchronous motors (IE4 motors).</p> <p>NOTE: This must not be used for lifting or applications where a more rapid build-up of the torque is required, as otherwise there would be overcurrent switch-offs or inversion of the motor on sudden changes of load, because the missing field would have to be compensated by a disproportionate torque current.</p> <p>101 = automatic, with the setting P219 = 101 an automatic magnetisation current controller is activated. The ISD controller then operates with a subordinate magnetizing controller, which improves the slippage calculation, especially at higher loads. The control times are considerably faster compared to the Normal ISD control (P219 = 100)</p>			

P2xx Control/characteristic curve parameters

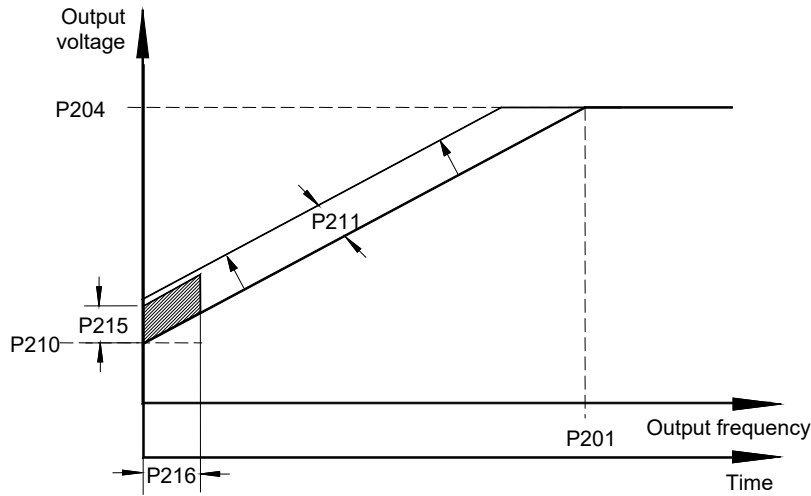

NOTE:
"typical"

Settings for the...

Current vector control (factory setting)
P201 to P209 = Motor data
P210 = 100%
P211 = 100%
P212 = 100%
P213 = 100%
P214 = 0%
P215 = no significance
P216 = no significance

Linear V/f characteristic curve
P201 to P209 = Motor data
P210 = 100% (static boost)
P211 = 0%
P212 = 0%
P213 = no significance
P214 = no significance
P215 = 0% (boost precontrol)
P216 = 0s (time dyn. boost)

P220	Par.-identification (Parameter identification)			P
0 ... 2 { 0 }	<p>For devices with an output up to 2.2 kW, the motor data is determined automatically by the device via this parameter. In many cases, better drive behaviour is achieved with the calibrated motor data. The identification of all parameters may take some time. During this time, do not switch of the mains voltage. If there is unfavourable operating behaviour after identification, select a suitable motor in P200 or set parameters P201 ... P208 manually.</p> <p>0 = No identification 1 = Rs identification : The stator resistance (display in P208) is determined by multiple measurements. 2 = Motor identification: This function can only be used with devices up to 2.2 kW. ASM: All motor parameters (P202, P203, P206, P208, P209) are determined. PMSM: Stator resistance (P208) and inductivity (P241) are determined.</p> <p>Note: Motor data identification should only be carried out with a cold motor (15 ... 25 °C). Warming of the motor during operation is taken into account. The FI must be in "Ready for operation" state. For BUS operation, the BUS must be operating without error. The motor power may only be one power level greater or three power levels lower than the nominal power of the FI. A maximum motor cable length of 20 m must be complied with for reliable identification. Before starting motor identification, the motor data must be pre-set according to the name plate or P200. At least the nominal frequency (P201), the nominal speed (P202), the voltage (P204), the power (P205) and the star delta con. (P207) must be known. Care must be taken that the connection to the motor is not interrupted during the entire measuring process. If the identification cannot be completed successfully, error message E019 is generated. After parameter identification, P220 is 0 again.</p>			

P240	EMF voltage PMSM (EMF voltage PMSM)		S	P												
0 ... 800 V { 0 }	<p>The EMF constant describes the self induction voltage of the motor. The value to be set can be found on the data sheet for the motor or on the type plate and is scaled to 1000 rpm. As the rated speed of the motor is not usually 1000 rpm, these details must be converted accordingly:</p> <p>Example:</p> <table border="0" style="width: 100%;"> <tr> <td style="width: 50%;">E (EMF - constant, type plate):</td> <td style="width: 50%;">89 V</td> </tr> <tr> <td>Nn (rated speed of motor):</td> <td>2100 rpm</td> </tr> <tr> <td colspan="2"><hr/></td> </tr> <tr> <td>Value in P240</td> <td>$P240 = E * Nn / 1000$</td> </tr> <tr> <td></td> <td>$P240 = 89 \text{ V} * 2100 \text{ rpm} / 1000 \text{ rpm}$</td> </tr> <tr> <td></td> <td>P240 = 187 V</td> </tr> </table> <p>0 = ASM is used, "Asynchronous machine is used": No compensation</p>	E (EMF - constant, type plate):	89 V	Nn (rated speed of motor):	2100 rpm	<hr/>		Value in P240	$P240 = E * Nn / 1000$		$P240 = 89 \text{ V} * 2100 \text{ rpm} / 1000 \text{ rpm}$		P240 = 187 V			
E (EMF - constant, type plate):	89 V															
Nn (rated speed of motor):	2100 rpm															
<hr/>																
Value in P240	$P240 = E * Nn / 1000$															
	$P240 = 89 \text{ V} * 2100 \text{ rpm} / 1000 \text{ rpm}$															
	P240 = 187 V															

5.2.4 Control parameters

Connection of an incremental encoder is not intended. Therefore, parameters that are exclusively used for encoder configuration (P301, P321–P328, P334) are not described in this manual. The respective parameters are nevertheless listed in the software of the device. **It must be ensured that these parameters are always left in the factory settings. Otherwise, proper operation of the frequency inverter cannot be guaranteed.**

Parameter group **P3xx** is typically hidden in the delivery state of the device, but is visible via NORDCON.

Parameter {Factory setting}	Setting value / Description / Note	Device	Supervisor	Parameter set
P300	Servo Mode (<i>Servo Mode</i>)			P
0 ... 1 { 0 }	<p>The control method for the motor is defined with this parameter.</p> <p>0 = Off (VFC open -loop) ¹⁾ Speed control without encoder feedback</p> <p>1 = On (CFC closed-loop) ²⁾ Speed control with encoder feedback</p> <p>NOTE: Commissioning information (📖 Abschnitt 4.2.1 "Explanation of the operating modes (P300)").</p> <p>1) Corresponds to the previous setting "OFF"</p> <p>2) Corresponds to the previous setting "ON"</p>			
<p>i Information Setting 1 = On (CFC closed loop)</p> <p>An incremental encoder can be evaluated. For this reason, setting 1 = On (CFC closed loop) has no effect.</p>				
P310	Speed controller P (<i>Speed controller P</i>)			P
0 ... 3200 % { 100 }	<p>P-component of the speed encoder (proportional amplification).</p> <p>Amplification factor, by which the speed difference between the setpoint and actual frequency is multiplied. A value of 100% means that a speed difference of 10% produces a setpoint of 10%. Values that are too high can cause the output speed to oscillate.</p>			
P311	Speed controller I (<i>Speed controller I</i>)			P
0 ... 800 % / ms { 20 }	<p>I-component of the encoder (Integration component).</p> <p>The integration component of the controller enables the complete elimination of any control deviation. The value indicates how large the setpoint change is per ms. Values that are too small cause the controller to slow down (reset time is too long).</p>			

P312	Torque current controller P <i>(Torque current controller P)</i>		S	P
0 ... 1000 % { 400 }	<p>Current controller for the torque current. The higher the current controller parameters are set, the more precisely the current setpoint is maintained. Excessively high values in P312 generally lead to high-frequency oscillations at low speeds; on the other hand, excessively high values in P313 generally produce low frequency oscillations across the whole speed range.</p> <p>If the value "Zero" is entered in P312 and P313, then the torque current control is switched off. In this case, only the motor model pre-control is used.</p>			
P313	Torque current controller I <i>(Torque current controller I)</i>		S	P
0 ... 800 % / ms { 50 }	<p>I-proportion of the torque current controller. (See also P312 >Torque current controller P<)</p>			
P314	Torque current controller limit <i>(Torque current controller limit)</i>		S	P
0 ... 400 V { 400 }	<p>Determines the maximum voltage increase of the torque current controller. The higher the value, the greater the maximum effect that can be exercised by the torque current controller. Excessive values in P314 can specifically lead to instability during transition to the field weakening zone (see P320). The values for P314 and P317 should always be set roughly the same, so that the field and torque current controllers are balanced.</p>			
P315	Field current controller P <i>(Field current controller P)</i>		S	P
0 ... 1000 % { 400 }	<p>Current controller for the field current. The higher the current controller parameters are set, the more precisely the current setpoint is maintained. Excessively high values for P315 generally lead to high frequency vibrations at low speeds. On the other hand, excessively high values in P316 generally produce low frequency vibrations across the whole speed range. If the value "Zero" is entered in P315 and P316, then the field current controller is switched off. In this case, only the motor model pre-control is used.</p>			
P316	Field current controller I <i>(Field current controller I)</i>		S	P
0 ... 800 % / ms { 50 }	<p>I-proportion of the field current controller. See also P315 >Field current controller P<</p>			
P317	Field current controller limit <i>(Field current controller limit)</i>		S	P
0 ... 400 V { 400 }	<p>Determines the maximum voltage increase of the field current controller. The higher the value, the greater is the maximum effect that can be exercised by the field current controller. Excessive values in P317 can specifically lead to instability during transition to the field reduction range (see P320). The values for P314 and P317 should always be set roughly the same, so that the field and torque current controllers are balanced.</p>			

P318	Field weakening controller P (Field weakening controller P)		S	P
0 ... 800 % { 150 }	The field weakening controller reduces the field setpoint when the synchronous speed is exceeded. Generally, the field weakening controller has no function; for this reason, the field weakening controller only needs to be set if speeds are set above the nominal motor speed. Excessive values for P318 / P319 will lead to controller oscillations. The field is not weakened sufficiently if the values are too small or during dynamic acceleration and/or delay times. The downstream current controller can no longer read the current setpoint.			
P319	Field weakening controller I (Field weakening controller I)		S	P
0 ... 800 % / ms { 20 }	Only affects the field weakening range, see P318 >Field weakening controller P<			
P320	Field weakening limit (Field weakening limit)		S	P
0 ... 110 % { 100 }	The field weakening limit determines at which speed / current the controller will begin to weaken the field. At a set value of 100% the controller will begin to weaken the field at approximately the synchronous speed. If values much larger than the standard values have been set in P314 and/or P317, then the field weakening limit should be correspondingly reduced, so that the control range is actually available to the current controller.			
P330	Rotor starting position detection (Rotor starting position detection) (Former designation: "PMSM Regulation ")		S	
0 ... 1 { 0 }	Selection of the method for determination of the starting position of the rotor (initial value of the rotor position) of a PMSM (Permanent Magnet Synchronous Motor). The parameter is only relevant for the control method "CFC closed-loop" (P300, setting "1").			
	<p>0 = Voltage controlled: With the first start of the machine, a voltage indicator is memorised which ensures that the rotor of the machine is set to the rotor position "zero". This type of starting position of the rotor can only be used if there is no counter-torque from the machine (e.g. flywheel drive) at frequency "zero". If this condition is fulfilled, this method of determining the position of the rotor is very precise (<1° electrical). In principle, this method is not suitable for lifting equipment, as there is always a counter-torque.</p> <p><u>For operation without encoders, the following applies:</u> Up to the switch over frequency P331 the motor (with the nominal current memorised) is driven under voltage control. Once the switch over frequency has been reached, the method of determining the rotor position is switched over to the EMF method. If, taking hysteresis (P332) into account, the frequency falls below the value in (P331), the frequency inverter switches back from the EMF method to voltage controlled operation.</p> <p>1 = Test signal method: The starting position of the rotor is determined with a test signal. This method also functions at a standstill with the brake applied, however it requires a PMSM with sufficient anisotropy between the inductivity of the d and q axes. The higher this anisotropy is, the greater the precision of the method. By means of parameter (P212) the voltage level of the test signal can be adjusted and with parameter (P213) the position of the motor position control can be adjusted. For motors which are suitable for use with the test signal method, a rotor position accuracy of 5°...10° electrical can be achieved (depending on the motor and the anisotropy).</p>			

P350	PLC functionality <i>(PLC functionality)</i>	S
0 ... 1 { 0 }	<p>Activate the integrated PLC</p> <p>0 = Off: the PLC is not active, the frequency inverter is actuated in accordance with parameters (P509) and (P510).</p> <p>1 = To: the PLC is active, frequency inverter is actuated via the PLC, depending on (P351). The definition of the main setpoints must be carried out accordingly in parameter (P553). Auxiliary setpoints (P510[-02]) can still be defined via (P546).</p>	
P351	PLC Setpoint selection <i>(PLC Setpoint selection)</i>	S
0 ... 3 { 0 }	<p>Selection of the source for the control word (STW) and the main setpoint (HSW) with active PLC functionality (P350 = 1). With the settings "0" and "1", the main setpoints are defined via (P553), but the definition of the auxiliary setpoints remains unchanged via (P546). This parameter is only taken over if the frequency inverter is in "Ready to start" status.</p> <p>0 = STW & HSW = PLC: The PLC supplies the control word (STW) and the main setpoint (HSW), and parameters (P509) and (P510[-01]) have no effect.</p> <p>1 = STW = P509: The PLC supplies the main setpoint (HSW), the control word (STW) corresponds to the setting in parameter (P509)</p> <p>2 = HSW = P510[1]: The PLC supplies the control word (STW), the source for the main setpoint (HSW) corresponds to the setting in parameter (P510[-01])</p> <p>3 = STW & HSW = P509/510: The source for the control word (STW) and the main setpoint (HSW) corresponds to the setting in parameter (P509)/(P510[-01])</p>	
P353	Bus status via PLC <i>(Bus status via PLC)</i>	S
0 ... 3 { 0 }	<p>This parameter can be used to determine how the control word (STW) for the master function and the status word (ZSW) of the frequency inverter undergo further processing by the PLC.</p> <p>0 = Off: The control word (STW) of the master function (P503≠0) and the status word (ZSW) undergo further processing by the PLC without change.</p> <p>1 = STW for broadcast: The control word (STW) for the master value function (P503≠ 0) is set by the PLC. In order to do this, the control word must be redefined in the PLC using process value "34_PLC_Busmaster_Control_word".</p> <p>2 = ZSW for bus: The status word (ZSW) of the frequency inverter is set by the PLC. In order to do this, the status word must be redefined in the PLC using process value "28_PLC_status_word".</p> <p>3 = STW Broadcast&ZSWBus: See setting 1 and 2</p>	

P355 [-01] ... [-10]	PLC Integer Setpoint <i>(PLC Integer Setpoint)</i>		S	
0x0000 ... 0xFFFF all = { 0 }		Data can be exchanged with the PLC via this INT array. This data can be used by the appropriate process variables in the PLC.		
P356 [-01] ... [-05]	PLC Long Setpoint <i>(PLC Long Setpoint)</i>		S	
0x0000 0000 ... 0xFFFF FFFF all = { 0 }		Data can be exchanged with the PLC via this DINT array. This data can be used by the appropriate process variables in the PLC.		
P360 [-01] ... [-05]	PLC display value <i>(PLC display value)</i>		S	
-2 000 000,000 ... 2 000 000,000 all = { 0.000 }		The parameter is only used to display the PLC Date. Via the corresponding process variables, this parameter can be written by the PLC. The values are not saved!		
P370	PLC Status <i>(PLC Status)</i>		S	
0 ... 63 _{dec} <i>ParameterBox:</i> 0x00 ... 0x3F <i>SimpleBox / ControlBox:</i> 0x00 ... 0x3F all = { 0 }		Displays the actual status of the PLC. Bit 0 = P350=1: Parameter P350 was set in the "Activate internal PLC" function Bit 1 = PLC active: The internal PLC is active. Bit 2 = Stop active: The PLC program is in "Stop" status. Bit 3 = Debug active: The error checking of the PLC program runs. Bit 4 = PLC error: The PLC has an error, but PLC user errors 23.xx are not displayed here. Bit 5 = PLC halted: The PLC program has been halted (<i>Single Step or Breakpoint</i>).		

5.2.5 Control terminals

Parameter {factory setting}	Setting value / Description / Note		Supervisor	Parameter set
P400 [-01] ... [-07]	Function Setpoint inputs (Setpoint inputs function)			P
0 ... 36 { [-01] = 1 } { [-02] = 0 } { [-03] = 0 } { [-04] = 0 } { [-05] = 0 } { [-06] = 0 } { [-07] = 0 }	<p>[-01] Analogue input 1, Function of analogue input 1 integrated in the FI</p> <p>[-02] Analogue input 2, Function of analogue input 1 integrated in the FI</p> <p>[-03] External Analogue input 1, AIN1 of the <u>first</u> I/O extension (SK xU4-IOE)</p> <p>[-04] External Analogue input 2, AIN2 of the <u>first</u> I/O extension (SK xU4-IOE)</p> <p>[-05] External A.in. 1 2nd IOEE, "External analogue input 1 2nd IOE", AIN1 of the <u>second</u> I/O extension (SK xU4-IOE) (= Analogue input 3)</p> <p>[-06] External A.in. 2 2nd IOE, "External analogue input 2 2nd IOE", AIN2 of the <u>second</u> I/O extension (SK xU4-IOE) (= Analogue input 4)</p> <p>[-07] Setpoint module</p>			

... Setting values below.

For standardisation of actual values:  Section 8.10 "Scaling of set-/actual values".

- 0 = Off**, the analogue input has no function. After the FI has been enabled via the control terminals, it will supply the set minimum frequency (P104).
- 1 = Setpoint frequency**, the given analogue range (P402/P403) varies the output frequency between the set minimum and maximum frequencies (P104/P105).
- 2 = Frequency addition ****, the supplied frequency value is added to the setpoint.
- 3 = Frequency subtraction ****, the supplied frequency value is subtracted from the setpoint.
- 4 = Minimum frequency**, setting for minimum frequency of frequency inverter
Lower limit: 1 Hz
Standardisation: 0 - 100% of P104
- 5 = Maximum frequency**, setting for maximum frequency of frequency inverter
Lower limit: 2 Hz
Standardisation: 0 - 100% of P105
- 6 = Actual value process controller ***, activates the process controller, analogue input is connected to the actual value encoder (compensator, air can, flow volume meter, etc.). The mode is set via the DIP switches of the I/O extension or in (P401).
- 7 = Setpoint process controller ***, as for Function 6, however, the setpoint is specified (e.g. by a potentiometer). The actual value must be specified using another input.
- 8 = Actual PI frequency ***, is required to build up a control loop. The analogue input (actual value) is compared with the setpoint (e.g. fixed frequency). The output frequency is adjusted as far as possible until the actual value equals the setpoint. (see control variables P413...P414)
- 9 = Actual freq. PI limited ***, "Actual frequency PI limited", as for function 8 "Actual frequency PI", however the output frequency cannot fall below the programmed minimum frequency value in Parameter P104. (no change to rotation direction)
- 10 = Actual freq. PID monitored ***, "Actual frequency PID monitored", as for function 8 Actual frequency PI", however the FI switches the output frequency off when the minimum frequency P104 is reached
- 11 = Torque current limit**, "Torque current limited" depends on parameter (P112). This value corresponds to 100% of the setpoint value. When the set limit value is reached, there is a reduction of the output frequency at the torque current limit.
- 12 = Torque current limit switch-off**, "Torque current limit switch-off" depends on parameter (P112). This value corresponds to 100% of the setpoint value. When the set limit value is reached, the device switches off with error code E12.3.

- 13 = Current limit**, "*Current limited*" depends on parameter (P536). This value corresponds to 100% of the setpoint value. When the set limit value is reached, the output voltage is reduced in order to limit the output current.
- 14 = Current switch-off**, "*Current limit switch-off*", depends on parameter (P536), this value corresponds to 100% of the setpoint value. When the set limit value is reached, the device switches off with error code E12.4.
- 15 = Ramp time**, normally only used in combination with a potentiometer.
Lower limit: 50 ms
Standardisation: $T_Rampenzeit = 10s * U[V] / 10V$ (U=Potentiometer voltage)
- 16 = Torque precontrol**, a function that enables a value for the anticipated torque requirement to be entered in the controller (interference factor switching). This function can be used to improve the load take-up of lifting equipment with separate load detection.
- 17 = Multiplication**, the setpoint is multiplied with the analogue value supplied. The analogue value adjusted to 100% then corresponds to a multiplication factor of 1.
- 18 = Curve travel calculator**, via the external analogue input (P400 [-03] or P400 [-04]) or via the BUS (P546 [-01 .. -03]) the master receives the actual speed from the slave. From its own speed, the slave speed and the guide speed, the master calculates the actual setpoint speed, so that neither of the two drives travels faster than the guide speed in the curve.
- 19 = ...reserved**
- 25 = Transfer Factor Gearing**, "*Gearing Transfer Factor*", is a multiplier to compensate for the variable transfer of a setpoint value. E.g.: Setting of the transformation between the master and the slave by means of a potentiometer.
- 26 = ...reserved**
- 30 = Motor temperature**: enables measurement of the motor temperature with a KTY-84 temperature sensor (📖 Section 4.4 "Temperature sensors")
- 33 = Setpoint Torque Proc. cntrl.**, "*Setpoint torque process controller*", for even distribution of the torques to coupled drive units (e.g.: S-roller drive). This function is also possible with the use of ISD control.
- 34 = d-correction F process** - (diameter correction, frequency PI / process controller).
- 35 = d-correction Torque** - (diameter correction, torque).
- 36 = d-correction F + Torque** - (diameter correction, frequency for PI / process controller and torque)

*) For further details of the PI and process controller, please refer to Section 8.2 "Process controller".

***) The limits of these values are formed by the parameters >minimum frequency auxiliary setpoint values< (P410) and the parameter >maximum frequency auxiliary setpoint values< (P411), whereby the limits defined by (P104) and (P105) cannot be undershot or overshoot.

P401	[-01] ... [-06]	Analog input mode (Mode analog input)		
-------------	-------------------------------------	---	--	--

0 ... 5
{ all 0 }

This parameter determines how the frequency inverter reacts to an analog signal which is less than the 0% adjustment (P402).

[-01] = Analog input 1: analog input 1, integrated into the FI

[-02] = Analog input 2: analog input 2, integrated into the FI

[-03] = External analog input 1, "External analog input 1": Analog input 1 of the first IO extension

[-04] = External analog input 2, "External analog input 2": Analog input 2 of the first IO extension

[-05] = External Analog input 1, 2nd IOE, "External analog input 1 of the 2nd IOE": Analog input 1 of the second IO extension

[-06] = External Analog input 2, 2nd IOE, "External analog input 2 of the 2nd IOE": Analog input 2 of the second IO extension

0 = 0 – 10V limited: An analogue setpoint smaller than the programmed adjustment 0% (P402) does not lead to undershooting of the programmed minimum frequency (P104), i.e. it does not result in a change of the direction of rotation.

1 = 0 – 10V: If a setpoint smaller than the programmed adjustment 0% (P402) is present, this can cause a change in direction rotation. This allows rotation direction reversal using a simple voltage source and potentiometer.

E.g. internal setpoint with rotation direction change: P402 = 5 V, P104 = 0 Hz, Potentiometer 0-10 V → Rotation direction change at 5 V in mid-range setting of the potentiometer.

At the moment of reversal (hysteresis = ± P505), the drive stands still when the minimum frequency (P104) is smaller than the absolute minimum frequency (P505). A brake that is controlled by the FI will have entered the hysteresis range.

If the minimum frequency (P104) is greater than the absolute minimum frequency (P505), the drive reverses when the minimum frequency is reached. In the hysteresis range ± P104, the FI supplies the minimum frequency (P104), the brake controlled by the FI is not applied.

2 = 0 – 10V monitored: If the minimum adjusted setpoint (P402) is undershot by 10% of the difference value from P403 and P402, the FI output switches off. Once the setpoint is greater than $[P402 - (10\% * (P403 - P402))]$, it will deliver an output signal again. With the change to firmware version V 1.1 R0 the behaviour of the FI changes in that the function is only active if a function for the relevant input has been selected in P400

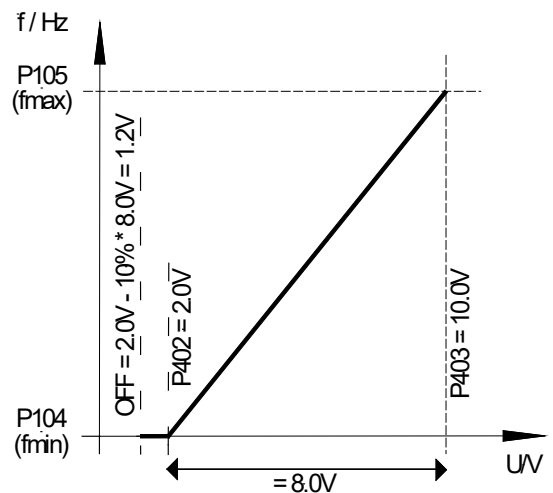

E.g. setpoint 4-20 mA: P402: Adjustment 0 % = 1 V; P403: Adjustment 100 % = 5 V; -10 % corresponds to -0.4 V; i.e. 1...5 V (4...20 mA) normal operating zone, 0.6...1 V = minimum frequency setpoint, below 0.6 V (2.4 mA) output switches off.

3 = - 10V – 10V: If a setpoint smaller than the programmed adjustment 0% (P402) is present, this can cause a change in direction rotation. This allows rotation direction reversal using a simple voltage source and potentiometer.

E.g. internal setpoint with rotation direction change: P402 = 5 V, P104 = 0 Hz, Potentiometer 0-10 V → Rotation direction change at 5 V in mid-range setting of the potentiometer.

At the moment of reversal (hysteresis = \pm P505), the drive stands still when the minimum frequency (P104) is smaller than the absolute minimum frequency (P505). A brake that is controlled by the FI will not have entered the hysteresis range.

If the minimum frequency (P104) is greater than the absolute minimum frequency (P505), the drive reverses when the minimum frequency is reached. In the hysteresis range \pm P104, the FI supplies the minimum frequency (P104), the brake controlled by the FI is not applied.

NOTE: The function -10 V – 10 V is a description of the method of function and not a reference to a bipolar signal (see example above).

4 = 0 – 10V with Error 1, "0 – 10V with shut-down on Error 1":

If the value of the 0% adjustment in (P402) is undershot, the error message 12.8 "Undershoot of Analogue In Min." is activated.

If the value of the 100% adjustment in (P402) is undershot, the error message 12.9 "Undershoot of Analogue In Max." is activated.

Even if the analogue value is outside the limits defined in (P402) and (P403), the setpoint value is limited to 0 - 100%.

The monitoring function only becomes active if an enable signal is present and the analogue value has reached the valid range (\geq (P402) or \leq (P403)) for the first time (e.g. pressure build-up after switching on a pump).

Once the function has been activated, it also operates if the actuation takes place via a field bus, for example, and the analogue input is not actuated at all.

5 = 0 – 10V m with Error 2, "0 – 10V with switch-off on Error 2":

See setting 4 ("0 - 10V with error switch off 1"), however:

In this setting the monitoring function only becomes active if an enable signal is present and the time during which the error monitoring is suppressed has elapsed. This suppression time is set in parameter (P216).

P402	[-01] Adjustment: 0% ... [-06] (Analog input adjustment: 0%)		S
-------------	--	--	----------

-50.00 ... 50.00 V
{ all 0.00 }

This parameter sets the voltage that should correspond with the minimum value of the selected function for the analog input.

-
- [-01] = Analog input 1:** analog input 1, integrated into the FI
 - [-02] = Analog input 2:** analog input 2, integrated into the FI
 - [-03] = External analog input 1, "External analog input 1":** Analog input 1 of the first IO extension
 - [-04] = External analog input 2, "External analog input 2":** Analog input 2 of the first IO extension
 - [-05] = External Analog input 1, 2nd IOE, "External analog input 1 of the 2nd IOE":** Analog input 1 of the second IO extension
 - [-06] = External Analog input 2, 2nd IOE, "External analog input 2 of the 2nd IOE":** Analog input 2 of the second IO extension

Typical setpoints and corresponding settings:

0 – 10 V	→	0.00 V
2 – 10 V	→	2.00 V (monitored for function 0-10 V)
0 – 20 mA	→	0.00 V (internal resistance approx. 250 Ω)
4 – 20 mA	→	1.00 V (internal resistance approx. 250 Ω)

Note: *Inner resistance* can be enabled via DIP switch (📖 Section 4.3.2.2 "DIP switches (S1, S2)")

SK xU4-IOE

Standardisation to typical signals, such as 0(2)-10V or 0(4)-20mA is carried out via the DIP switch on the I/O-extension module. In this case, additional adjustment of parameters (P402) and (P403) must **not** be carried out.

P403	[-01] Adjustment: 100%		S
	[-06] ... (Analog input adjustment: 100%)		

-50.00 ... 50.00 V
{ all 0.00 }

This parameter sets the voltage that should correspond with the maximum value of the selected function for the analog input.

- [-01] = Analog input 1:** analog input 1, integrated into the FI
- [-02] = Analog input 2:** analog input 2, integrated into the FI
- [-03] = External analog input 1, "External analog input 1":** Analog input 1 of the first IO extension
- [-04] = External analog input 2, "External analog input 2":** Analog input 2 of the first IO extension
- [-05] = External Analog input 1, 2nd IOE, "External analog input 1 of the 2nd IOE":** Analog input 1 of the second IO extension
- [-06] = External Analog input 2, 2nd IOE, "External analog input 2 of the 2nd IOE":** Analog input 2 of the second IO extension

Typical setpoints and corresponding settings:

- 0 – 10 V → 10.00 V
- 2 – 10 V → 10.00 V (monitored for function 0-10 V)
- 0 – 20 mA → 5.00 V (internal resistance approx. 250 Ω)
- 4 – 20 mA → 5.00 V (internal resistance approx. 250 Ω)

Note: Inner resistance can be enabled via DIP switch (📖 Section 4.3.2.2 "DIP switches (S1, S2)")

SK xU4-IOE

Standardisation to typical signals, such as 0(2)-10V or 0(4)-20mA is carried out via the DIP switch on the I/O-extension module. In this case, additional adjustment of parameters (P402) and (P403) must **not** be carried out.

P400 ... P403

P401 = 0 → 0 - 10V limited

P401 = 1 → 0 - 10V not limited

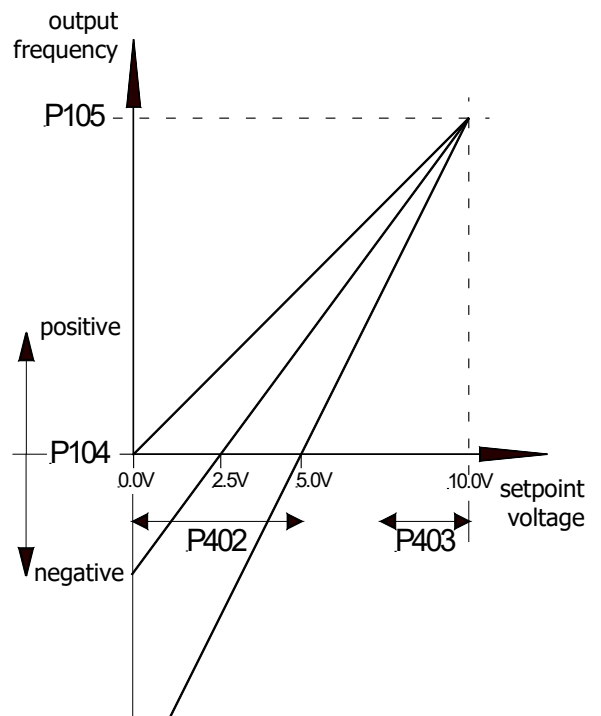
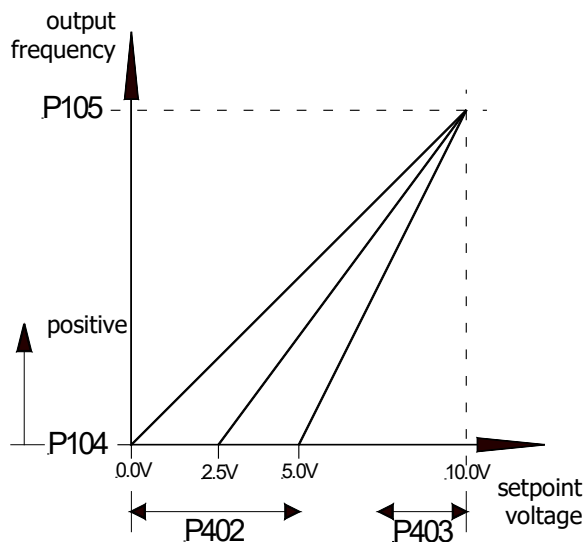

P404	[-01] Analogue input filter [-02] (analogue input filter)		S	
10 ... 400 ms { all 100 }	Adjustable digital low-pass filter for the analogue signal. Interference peaks are hidden, the reaction time is extended. [-01] = Analogue input 1: analogue input 1 integrated in the device [-02] = Analogue input 2: analogue input 2 integrated in the device The filter time for the analogue inputs of the optional external IO extension modules is set in the parameter set for the relevant module (P161).			
P410	Min. freq. a-in 1/2 (Minimum frequency a-in 1/2 (auxiliary setpoint value))			P
-400.0 ... 400.0 Hz { 0.0 }	The minimum frequency that can act on the setpoint via the auxiliary setpoints. Auxiliary setpoints are all frequencies that are additionally delivered for further functions in the FI: Actual frequency PID Frequency addition Frequency subtraction Auxiliary setpoints via BUS Process controller Min. frequency above analog setpoint (potentiometer)			
P411	Max. freq. a-in 1/2 (Maximum frequency a-in 1/2 (auxiliary setpoint value))			P
-400.0 ... 400.0 Hz { 50.0 }	The maximum frequency that can act on the setpoint via the auxiliary setpoints. Auxiliary setpoints are all frequencies that are additionally delivered for further functions in the FI: Actual frequency PID Frequency addition Frequency subtraction Auxiliary setpoints via BUS Process controller Min. frequency above analog setpoint (potentiometer)			
P412	Nom. val. process ctrl. (Nominal value process controller)		S	P
-10.0 ... 10.0 V { 5.0 }	Fixed specification of a setpoint for the process controller that will only occasionally be altered. Only with P400 = 14 ... 16 (process controller) (see chapter 8.2 "Process controller").			
P413	P-component of PI-controller (P-component PI-controller)		S	P
0.0 ... 400.0 % { 10.0 }	This parameter is only effective when the function PI controller actual frequency is selected. The P-component of the PI controller determines the frequency jump if there is a control deviation based on the control difference. E.g.: At a setting of P413 = 10% and a rule difference of 50%, 5% is added to the actual setpoint.			
P414	I-component PI-controller (I-component of PI-controller)		S	P
0.0 ... 3,000.0 %/s { 10.0 }	This parameter is only effective when the function PI controller actual frequency is selected. The I-component of the PI controller determines the frequency change, dependent on time. Note: In contrast to other NORD series, parameter P414 is smaller by a factor of 100 (Reason: better setting ability with small I-proportions).			
P415	Process controller limit (Control limit of process controller)		S	P
0 ... 400.0 % { 10.0 }	This parameter is only effective when the function PI process controller is selected. This determines the control limit (%) after the PI controller (see chapter 8.2 "Process controller").			

P416	Ramp time PI setpoint <i>(Ramp time PI setpoint value)</i>		S	P
0.00 ... 99.99 sec { 2.00 }	This parameter is only effective when the function PI process controller is selected. Ramp for PI setpoint			
P417 [-01] ... [-02]	Offset analogue output <i>(Offset analogue output)</i>		S	P
-10.0 ... 10.0 V { all 0.0 } only with SK CU4-IOE or SK TU4-IOE	<p>[-01] = First IOE, AOUT of the <u>first</u> I/O extension (SK xU4-IOE) [-02] = Second IOE, AOUT of the <u>second</u> I/O extension (SK xU4-IOE)</p> <p>In the analogue output function an offset can be entered to simplify the processing of the analogue signal in other equipment.</p> <p>If the analogue output has been programmed with a digital function, then the difference between the switch-on point and the switch-off point can be set in this parameter (hysteresis).</p>			

P418 [-01] ... [-02]	Analog output func. (Analogue output function)		S	P
0 ... 60 { all 0 }	[-01] = IOE-1	<ul style="list-style-type: none"> • AOUT of first IOE extension (type SK xU4-IOE) or • AOUT1 of I/O extension of type SK xU4-IOE2 		
	[-02] = IOE-2	<ul style="list-style-type: none"> • AOUT of second IOE extension (type SK xU4-IOE) • AOUT2 of I/O extension of type SK xU4-IOE2 		

... only with
SK CU4-IOE or
SK TU4-IOE

Analogue functions (max. load: 5 mA analogue):

An analogue voltage (0 ... +10 V) can be obtained at the control terminals (max. 5 mA). Various functions are available, where the following basically applies:

- 0 V analogue voltage always corresponds to 0% of the selected value.
- 10 V always corresponds to the nominal motor value (unless otherwise stated) multiplied by the P419 scaling factor, e.g.:

$$\Rightarrow 10 \text{ Volt} = \frac{\text{Nominal motor value} \times \text{P419}}{100\%}$$

With regard to scaling of actual values: (📖 Section 8.10 "Scaling of set-/actual values").

- 0 = No function**, no output signal at the terminals
- 1 = Actual frequency***, the analogue voltage is proportional to the FI output frequency. (100%=(P201))
- 2 = Actual speed***, synchronous speed calculated by the FI based on the present setpoint. Load-dependent speed fluctuations are not taken into account. If servo mode is used, the measured speed will be output via this function. (100%=(P202))
- 3 = Current***, effective value of the output current supplied by the FI. (100%=(P203))
- 4 = Torque current***, displays the motor load torque calculated by the FI. (100% = (P112))
- 5 = Voltage***, output voltage supplied by the FI. (100%=(P204))
- 6 = D.c. link voltage**, "Link circuit voltage", is the DC voltage in the FI. This is not based on the nominal motor data. 10 V with 100% scaling, corresponds to 450 V DC (230 V mains) or 850 V DC (480 V mains)!
- 7 = Value of P542**, the analogue output can be set using parameter P542, irrespective of the actual operating status of the FI. For example, in case of bus control (parameter order), this function may deliver an analogous value from the FI, triggered by the control unit.
- 8 = Apparent power***, the actual apparent power calculated by the FI. (100%=(P203)*(P204) or = (P203)*(P204)*√3)
- 9 = Real Power***, actual effective power calculated by the FI. (100%=(P203)*(P204)*(P206) or = (P203)*(P204)*(P206)*√3)
- 10 = Torque [%]***, actual torque calculated by the FI (100% = Nominal motor torque)
- 11 = Field [%]***, actual field in the motor calculated by the FI.
- 12 = Actual frequency+/-***, analogue voltage is proportional to the output frequency of the FI, where the zero point has been shifted to 5 V. For CW direction of rotation, values from 5 V to 10 V are output, and for CCW direction of rotation, values from 5 V to 0 V.
- 13 = Speed +/-***, synchronous speed calculated by the FI, based on the present setpoint, where the zero point has been shifted to 5 V. Values of 5 V to 10 V are output with CW direction of rotation, and values of 5 V to 0 V are output with CCW direction of rotation. If servo mode is used, the measured speed is output via this function.
- 14 = Torque [%]***, actual torque calculated by the FI, where the zero point has been shifted to 5 V. For motor torques, values between 5 V and 10 V are output, and for generator torques, values between 5 V and 0 V.
- 29 = Reserved**, for POSICON, see [BU0210](#)

- 30 = Set freq. befor ramp**, “Setpoint frequency before ramp”, displays the frequency resulting from any upstream controllers (ISD, PID, ...). This is then the setpoint frequency for the power stage after it has been adjusted via the acceleration or deceleration (P102, P103) ramp.
- 31 = Output via Bus PZD**, the analogue output is controlled via a bus system. The process data is transferred directly (P546="32").
- 33 = Set freq Motorpot**, “Setpoint frequency motor potentiometer”
- 60 = Value of PLC**, the analogue output is set by the integrated PLC, irrespective of the current operating status of the FI.

*) Values are based on the motor data (P201 ...) or have been calculated from them.

P419 [-01] [-02]	Standard Analogue output (Standardisation of analogue output)		S	P
-500 ... 500 % { all 100 }	[-01] = First IOE , AOUT of the <u>first</u> I/O extension (SK xU4-IOE) [-02] = Second IOE , AOUT of the <u>second</u> I/O extension (SK xU4-IOE)			
only with SK CU4-IOE or SK TU4-IOE	Using this parameter an adjustment can be made to the analogue output for the selected operating zone. The maximum analogue output (10 V) corresponds to the standardisation value of the appropriate selection. If therefore, at a constant working point, this parameter is raised from 100 % to 200 %, the analogue output voltage is halved. 10 Volt output signal then corresponds to twice the nominal value. For negative values the logic is reversed. An actual value of 0 % will then produce 10 V at the output and -100 % will produce 0 V.			
P420 [-01] ... [-05]	Digital inputs (Digital inputs)			
0 ... 80 { [-01] = 1 } { [-02] = 2 } { [-03] = 4 } { [-04] = 0 } { [-05] = 0 }	Up to 3 freely programmable digital inputs are available. The analogue inputs can also still be used as digital inputs, but their electrical characteristics are not compatible with the PLC standard. [-01] Digital input 1 (DIN1), Enable right (default), control terminal 21 [-02] Digital input 2 (DIN2), Enable left (default), control terminal 22 [-03] Digital input 3 (DIN3), Fixed frequency 1 (default), control terminal 23 [-04] Analogue input 1 (AIN1/DIN4), no function (default), control terminal 14 [-05] Analogue input 2 (AIN2/DIN5), no function (default), control terminal 16 The additional digital inputs of the I/O- extensions (SK xU4-IOE) are administered via the parameter "Bus I/O In Bit (4...7)" - (P480 [-05] ... [-08]) for the <u>first</u> I/O extension, and via the parameter "Bus I/O In Bit (0...3)" - (P480 [-01] ... [-04]) for the <u>second</u> I/O extension.			

List of possible digital input functions P420

Value	Function	Description	Signal
00	No function	Input switched off.	---
01	Enable right	The FI delivers an output signal with the rotating field “right”, if a positive setpoint is applied: 0 → 1 edge (P428 = 0)	Hig h
02	Enable left	The FI delivers an output signal with the rotating field “left”, if a positive setpoint is applied: 0 → 1 edge (P428 = 0)	Hig h
<p>If the drive is to start automatically when the mains voltage is switched on (P428 = 1), a permanent High level for enabling must be provided (supply control terminal 21 with 24 V).</p> <p>If the functions “Enable right” and “Enable left” are actuated simultaneously, the FI is blocked.</p> <p>If the frequency inverter is in fault status but the cause of the fault is no longer present, the error message is acknowledged with a 1 → 0 edge.</p>			
03	Phase seq. reversal	Causes the rotating field to change direction (in combination with “Enable right” or “Enable left”).	Hig h
04¹	Fixed frequency 1	The frequency from P465 [01] is added to the actual setpoint.	Hig h

Value	Function	Description	Signal
05 ¹	Fixed frequency 2	The frequency from P465 [02] is added to the actual setpoint.	High
06 ¹	Fixed frequency 3	The frequency from P465 [03] is added to the actual setpoint.	High
07 ¹	Fixed frequency 4	The frequency from P465 [04] is added to the actual setpoint.	High
If several fixed frequencies are controlled simultaneously, they are added with the correct sign. In addition, the analogue setpoint (P400) and, if necessary, the minimum frequency (P104) are added.			
08 ⁴	Param. set switching "Parameter set switching 1"	Selection of the active parameter set 1 ... 4 – first bit.	High
09	Maintain the freq.	During the acceleration or deceleration phase, a Low level will cause the actual output frequency to be "Maintained". A High level allows the ramp to continue.	Low
10 ²	Voltage disable	The FI output voltage is switched off; the motor will freely come to a stop.	Low
11 ²	Quick stop	The FI reduces the frequency according to the programmed quick stop time P426.	Low
12 ²	Fault acknowledgem.	Fault acknowledgement with an external signal. If this function is not programmed, a fault can also be acknowledged by a Low enable setting (P506).	0→1 edge
13 ²	PTC resistor input	Only with the use of a thermostat (bimetallic switching contact). Switch-off delay = 2 sec, warning after 1 sec.	High
14 ^{2,3}	Remote control	With bus system control, a Low level switches to control via control terminals.	High
15	Jog frequency ¹	Also for control via SimpleBox or ParameterBox, the frequency value from (P113) can be set directly using the HIGHER/LOWER keys and saved in (P113) using the OK key. If the device is operated with jog frequency, any active bus control is disabled.	High
16	Motor potentiometer	Same as setting value 09, but the frequency is not maintained below the minimum frequency P104 and above the maximum frequency P105.	Low
17 ⁴	ParaSetSwitching 2 "Parameter set switching 2"	Selection of the active parameter set 1 ... 4 – second bit.	High
18 ²	Watchdog	The input must see a High edge cyclically (P460), otherwise error E012 will cause a switch-off. Function starts with the 1 st High edge.	0→1 edge
19	Setpoint 1 on / off	Analogue input switch-on and switch-off 1/2 (High = ON) The Low signal sets the analogue input to 0%, which does not result in shutdown when the minimum frequency (P104) > absolute minimum frequency (P505).	High
20	Setpoint 2 on / off		High
21	... 28 Reserved		
29	Enable SK SSX-box	The enable signal is delivered by the <i>Simple Setpoint Box</i> (setpoint unit) SK SSX-3A, whereby the unit must be operated in IO-S mode. → BU0040	High
30	Inhibit PID	Switching the PID control/process controller function on or off (High = ON)	High
31 ^{2,5}	Inhibit turn right	Blocks the >Enable right/Enable left< via a digital input or bus control. Does not relate to the actual phase sequence of the motor (e.g. following negated setpoint).	Low
32 ^{2,5}	Inhibit turn left		Low
33	... 43 Reserved		
44	3-Wire-Direction "3-wire control direction change" (normally open switch)		0→1 edge

Value	Function	Description	Signal
45	3-W-Ctrl. Start-Right "3-wire-control Start-Right" (normally open switch)	This control function provides an alternative to "Enable right"/"Enable left" (01/02), which requires permanently applied levels. In this case, only a control pulse is required to trigger the function. The FI can therefore be controlled entirely via switches.	0→1 edge
46	3-W-Ctrl.Start-Left "3-wire control Start-Left" (normally open switch)		0→1 edge
49	3-Wire-Ctrl.Stop "3-wire control Stop" (normally closed switch)		1→0 edge
47	Motorpot. Freq. + "Motor potentiometer frequency +"	In combination with "Enable right"/"Enable left", the output frequency can be continuously varied. To save a current value in P113, both inputs must be at a High voltage for 0.5 s. This value is then used as the next starting value for the same preselection of direction ("Enable right"/"Enable left"), otherwise start at f_{MIN} .	High
48	Motorpot. Freq. - "Motor potentiometer frequency -"		High
50	Bit0 fixedfreq.Array	Binary coded digital inputs to generate up to 15 fixed frequencies (P465: [-01] ... [-15])	High
51	Bit1 fixedfreq.Array		High
52	Bit2 fixedfreq.Array		High
53	Bit3 fixedfreq.Array		High
55	... 64 Reserved		
65 ²	Brake man/auto rel. "Release brake manually/automatically"	The brake is automatically released by the frequency inverter (automatic brake control) or if this digital input has been set.	High
66 ²	Brake man Release "Release brake manually"	The brake is only released if the digital input is set.	High
67	Dig.out man/auto set "Set digital output manually/automatically"	Set digital output 1 manually or via the set function in (P434).	High
68	Dig.out manual set "Set digital output manually"	Set digital output 1 manually	High
69	Speed meas.with ini. "Speed measurement with initiator"	Simple speed measurement (pulse measurement) with initiator	Pulses
70	Reserved		
71	Motorpot.F+ and Save "Motor potentiometer function Frequency + with automatic saving"	With this "motor potentiometer function", a setpoint (sum) is set via the digital inputs, and simultaneously saved. With control enabling R/L, this is then started up in the correspondingly enabled phase sequence. The frequency is retained on change of direction. Simultaneous activation of the +/- function causes the frequency setpoint to be set to zero.	High
72	Motorpot.F- and Save "Motor potentiometer function Frequency - with automatic saving".	The frequency setpoint can also be displayed or set in the operating value display (P001 = 30, 'Cur. set value MP-S'), or in P718. Any minimum frequency (P104) set is still effective. Other setpoint values, e.g. analogue or fixed frequencies can be added or subtracted. The setpoint adjustment is performed with the ramps from P102/103.	High
73 ^{2,5}	Inhibit right+quick "Inhibit right running+Quick stop"	Same as setting 31, but coupled to the "Quick stop" function.	Low
74 ^{2,5}	Inhibit left + quick "Inhibit left running + quick stop"	Same as setting 32, but coupled to the "Quick stop" function.	Low
75	DO 2 man/auto set "Set digital output manually/automatically"	2 Same as function 67, but for digital output 2 (SK 2x0E only)	High

Value	Function	Description	Signal															
76	DO 2 man. set "Set digital output 2 manually"	Same as function 68, but for digital output 2 (SK 2x0E only)	High															
77	... 79 Reserved																	
80	PLC stop	The program execution of the integrated PLC is stopped for as long as the signal is present.	High															
1	If no digital input is parameterised for "Enable right" or "Enable left", control of a fixed frequency or jog frequency enables the frequency inverter. The rotating field direction depends on the sign of the setpoint.																	
2	Also effective for control via BUS (e.g. RS232, RS485, CANopen, AS-Interface, ...)																	
3	Function cannot be selected via BusIO In Bits																	
4	<p>The operating parameter set is selected via correspondingly parameterised digital inputs or the BUS control. Switching can take place during operation (online). Coding is binary according to the following pattern.</p> <p>When enabled via the keyboard (SimpleBox, ControlBox, PotentiometerBox or ParameterBox), the operating parameter set will match the setting in P100.</p> <table border="1" data-bbox="877 622 1439 801"> <thead> <tr> <th>Setting</th> <th>Digital input Function [8]</th> <th>Digital input Function [17]</th> </tr> </thead> <tbody> <tr> <td>0 = Parameter set 1</td> <td>LOW</td> <td>LOW</td> </tr> <tr> <td>1 = Parameter set 2</td> <td>HIGH</td> <td>LOW</td> </tr> <tr> <td>2 = Parameter set 3</td> <td>LOW</td> <td>HIGH</td> </tr> <tr> <td>3 = Parameter set 4</td> <td>HIGH</td> <td>HIGH</td> </tr> </tbody> </table>			Setting	Digital input Function [8]	Digital input Function [17]	0 = Parameter set 1	LOW	LOW	1 = Parameter set 2	HIGH	LOW	2 = Parameter set 3	LOW	HIGH	3 = Parameter set 4	HIGH	HIGH
Setting	Digital input Function [8]	Digital input Function [17]																
0 = Parameter set 1	LOW	LOW																
1 = Parameter set 2	HIGH	LOW																
2 = Parameter set 3	LOW	HIGH																
3 = Parameter set 4	HIGH	HIGH																
5	Notice! When using this function for limit switch monitoring, it must be ensured that the limit switch cannot be overrun, because as soon as the limit switch has been left, the blocking of the phase sequence is automatically cancelled. The frequency inverter therefore accelerates again when the enable signal is applied.																	

P426	Quick stop time (Quick stop time)		S	P
0 ... 320.00 sec { 0.10 }	<p>Setting of the stop time for the fast stop function which can be triggered either via a digital input, the bus control, the keyboard or automatically in case of a fault.</p> <p>Emergency stop time is the time for the linear frequency decrease from the set maximum frequency (P105) to 0Hz. If an actual setpoint <100% is being used, the emergency stop time is reduced correspondingly.</p>			
P427	Quick stop on error (Quick stop on error)		S	
0 ... 3 { 0 }	<p>Activation of automatic emergency stop following error</p> <p>0 = OFF: Automatic emergency stop following error is deactivated</p> <p>1 = Mains supply failure: Automatic emergency stop following mains supply failure</p> <p>2 = In case of faults: Automatic emergency stop following fault</p> <p>3 = Fault or mains failure: Automatic emergency stop in case of fault or mains failure</p> <p>An emergency stop can be triggered by the errors E2.x, E7.0, E10.x, E12.8, E12.9 and E19.0.</p>			

P428	Automatic start (Automatic start)		S	P
0 ... 1 { 0 }	<p>In the standard setting (P428 = 0 → Off) the inverter requires a flank to enable (signal change from "low → high") at the relevant digital input.</p> <p>In the setting On → 1 the FI reacts to a High level. This function is only possible if the FI is controlled using the digital inputs. (see P509=0/1)</p> <p>In certain cases, the FI must start up directly when the mains are switched on. For this P428 = 1 → On can be set. If the enable signal is permanently switched on, or equipped with a cable jumper, the FI starts up immediately.</p> <p>NOTE: (P428) not "ON" if (P506) = 6, Danger! (See note on (P506))</p> <p>NOTE: The "Automatic Start" function can only be used if a digital input of the <u>frequency inverter</u> (DIN 1 ...) is parameterised to the function "Enable Right" or "Enable Left" and this input is permanently set to "High". The digital inputs of the technology modules (e.g.: SK CU4 - IOE) do not support this "Automatic Start" function!</p> <p>NOTE: The "Automatic Start" function can only be activated if the frequency inverter has been parameterised to local control ((P509) setting { 0 } or { 1 }).</p>			
P434 [-01] [-02]	Digital out function (Digital output function)			
0 ... 40 { [-01] = 7 } { [-02] = 1 }	<p>[-01] = Digital output 1, Digital output 1 of the frequency inverter</p> <p>[-02] = Digital output 2, Digital output 2 of the frequency inverter</p> <p>Settings 3 to 5 and 11 work with 10% hysteresis, i.e. the output delivers (function 11 does not deliver) on reaching the 24 V limit and switches this off again when the value drops to a value that is 10% lower (function 11 on again).</p> <p>This behaviour can be inverted with a negative value in P435.</p>			
				Output ... with limit or function (See also P435)
	0 = No function			Low
	1 = External brake , to control an external 24 V brake relay (max. 20 mA). The output switches at a programmed absolute minimum frequency (P505). For typical brakes, a setpoint delay of 0.2-0.3 s (see also P107/P114) should be programmed.			Low
	2 = Inverter is working , the output indicates voltage at the output (U - V - W).			High
	3 = Current limit , based on the setting of the nominal current (P203). This value can be adjusted via scaling (P435).			High
	4 = Torque current limit : based on motor data settings in P203 and P206. Signals a corresponding torque load on the motor. This value can be adjusted via scaling (P435).			High
	5 = Frequency limit , based on nominal frequency setting in P201. This value can be adjusted via scaling (P435).			High
	6 = Level with setpoint , indicates that the FI has completed the frequency increase or decrease. Setpoint frequency = Actual frequency! From a difference of 1 Hz → Setpoint not reached – Signal low.			High
	7 = Fault , general fault message, fault is active or not yet acknowledged. → Fault - Low (Ready for operation - High)			Low
	8 = Warning , general warning, a limit was reached that could lead to a later switch-off of the FI.			Low
	9 = Overcurrent warning , at least 130% of the nominal FI current was supplied for 30 seconds.			Low

10 = Mot. overtemp. warning , "Motor overtemperature warning" The motor temperature is evaluated. → Motor is too hot. The warning is given immediately, overtemperature switch-off after 2 seconds.	Low
11 = Torque current limit , "Torque current limit/current limit active warning": The limit value in P112 or P536 has been reached. A negative value in P435 inverts the behaviour. Hysteresis = 10 %.	Low
12 = Value of P541 , "Value of P541 – external control", the output can be controlled with parameter P541 (Bit 0) independent of the actual operating status of the FI.	High
13 = Torq.curr. limit gen , "Generated torque current limit active": Limit value in P112 was reached in the generator range. Hysteresis = 10 %	High
16 = Comparison val. AIN1 , Setpoint AIN1 of the FI is compared with the value in (P435[-01 or -02]).	High
17 = Comparison val. AIN2 , Setpoint AIN2 of the FI is compared with the value in (P435[-01 or -02]).	High
18 = Inverter ready : The FI is ready for operation. After being enabled, it delivers an output signal.	High
19 = ... 29 reserved	
30 = Status dig in 1	High
31 = Status dig in 2	High
32 = Status dig in 3	High
33 = Status dig in 4 / AIN1	High
34 = Status dig in 5 / AIN2	High
38 = Value Bus Setpoint	High
39 = STO inactive	High
40 = Output via PLC , the output is set by the integrated PLC	High

P435	[-01] Dig. out scaling			
	[-02] (Scaling of digital output)			

-400 ... 400 %
{ 100 }

[-01] = Digital output 1, Digital output 1 of the frequency inverter
[-02] = Digital output 2, Digital output 2 of the frequency inverter

Adjustment of the limiting values of the output function. For a negative value, the output function will be output negative.

Reference to the following values:

Current limit (3) = x [%] · P203 >Rated motor current<

Torque current limit (4) = x [%] · P203 · P206 (calculated rated motor torque)

Frequency limit (5) = x [%] · P201 >Rated motor frequency<

P436	[-01] Dig. out. hysteresis [-02] (Hysteresis of digital outputs)		S	
1 ... 100 % { 10 }	[-01] = Digital output 1 , Digital output 1 of the frequency inverter [-02] = Digital output 2 , Digital output 2 of the frequency inverter			Difference between switch-on and switch-off point to prevent oscillation of the output signal.
P460	Watchdog time (Watchdog time)		S	
-250.0 ... 250.0 s { 10.0 }	0.1 ... 250.0 = The time interval between the expected watchdog signals (programmable function of digital inputs P420 ...). If this time interval elapses without a pulse being registered, a switch-off occurs with error message E012. 0.0 = Customer error: As soon as a High-Low edge or a Low signal is registered on a digital input (function 8), the FI switches off with fault message E012. -250.0 ... -0.1 = In this setting, the monitoring of the rotor run (watchdog) becomes active. The time is defined by the set value. If the device is switched off, no watchdog message is issued. After each enable, a pulse must first come before the watchdog is activated.			
P464	Fixed frequencies mode (Fixed frequencies mode)		S	
0 ... 1 { 0 }	This parameter determines the form in which fixed frequencies are to be processed. 0 = Addition to main setpoint: Fixed frequencies and the fixed frequency array are added to each other. I.e. they are added together, or added to an analog setpoint to which limits are assigned according to P104 and P105. 1 = Main setpoint: Fixed frequencies are not added - neither together, nor to analog setpoints. If for example, a fixed frequency is switched to an existing analog setpoint, the analog setpoint will no longer be considered. Programmed frequency addition or subtraction with an analog input value or a bus setpoint is still possible and valid, as is the addition to the setpoint of a motor potentiometer function (function of digital inputs: 71/72) If several fixed frequencies are selected simultaneously, the frequency with the highest value has priority (E.g.: <u>20</u> >10 or <u>20</u> >-30). Note: The highest active fixed frequency is added to the setpoint value of the motor potentiometer if the functions 71 or 72 are selected for 2 digital inputs.			

P465 [-01] Fixed frequency field ... [-15] <i>(Fixed frequency / Frequency array)</i>				
-400.0 ... 400.0 Hz { [-01] = 5.0 } { [-02] = 10.0 } { [-03] = 20.0 } { [-04] = 35.0 } { [-05] = 50.0 } { [-06] = 70.0 } { [-07] = 100.0 } { [-08] = 0.0 } { [-09] = -5.0 } { [-10] = -10.0 } { [-11] = -20.0 } { [-12] = -35.0 } { [-13] = -50.0 } { [-14] = -70.0 } { [-15] = -100.0 }	In the array levels, up to 15 different fixed frequencies can be set, which in turn can be encoded for the functions 50...54 in binary code for the digital inputs. [-01] = Fixed frequency 1 / Array 1 [-02] = Fixed frequency 2 / Array 2 [-03] = Fixed frequency 3 / Array 3 [-04] = Fixed frequency 4 / Array 4 [-05] = Fixed frequency / Array 5 [-06] = Fixed frequency / Array 6 [-07] = Fixed frequency / Array 7 [-08] = Fixed frequency / Array 8		[-09] = Fixed frequency / Array 9 [-10] = Fixed frequency / Array 10 [-11] = Fixed frequency / Array 11 [-12] = Fixed frequency / Array 12 [-13] = Fixed frequency / Array 13 [-14] = Fixed frequency / Array 14 [-15] = Fixed frequency / Array 15	
P466 Min.freq. process cont. <i>(Minimum frequency process controller)</i>			S	P
0.0 ... 400.0 Hz { 0.0 }	With the aid of the minimum frequency process controller the control ratio can also be kept to a minimum ratio, even with a master value of "zero", in order to enable adjustment of the compensator. More details can be found in P400 and (chapter 8.2).			
P475 [-01] delay on/off switch ... [-05] <i>(Digital function switch on/off delay)</i>			S	
-30,000 ... 30,000 sec { 0,000 }	Adjustable switch-on/off delay for the digital inputs and the digital functions of the analogue inputs. Use as a switch-on filter or simple process control is possible. [-01] = Digital input 1 [-02] = Digital input 2 [-03] = Digital input 3 [-04] = Digital input 4 / AIN1 [-05] = Digital input 5 / AIN2		Positive values = switch-on delayed Negative values = switch-off delayed	

P480	[-01]	Function BusIO In Bits		
	...	<i>(Bus I/O In Bits function)</i>		
	[-12]			
<p>0 ... 80</p> <p>{ [-01] = 01 }</p> <p>{ [-02] = 02 }</p> <p>{ [-03] = 05 }</p> <p>{ [-04] = 12 }</p> <p>{ [-05...-12] = 00 }</p>				
<p>The Bus I/O In Bits are perceived as digital inputs. They can be set to the same functions (P420). With devices with an integrated AS interface, the I/O bits can be used by the interface itself (bit 0 ... 3) or in combination with I/O extensions (SK xU4-IOE) (bits 4 ... 7 and bits 0 ... 3). <i>With AS-i devices, the priority is AS-i. In this case BUS IO BITS 1 ... 4 cannot be used by the 2nd. IO extension.</i></p> <p>[-01] = Bus / AS-i Dig In1 (Bus IO In Bit 0 + AS-i 1 or DI 1 of the second SK xU4-IOE (DigIn 09)) [-02] = Bus / AS-i Dig In2 (Bus IO In Bit 1 + AS-i 2 or DI 2 of the second SK xU4-IOE (DigIn 10)) [-03] = Bus / AS-i Dig In3 (Bus IO In Bit 2 + AS-i 3 or DI 3 of the second SK xU4-IOE (DigIn 11)) [-04] = Bus / AS-i Dig In4 (Bus IO In Bit 3 + AS-i 4 or DI 4 of the second SK xU4-IOE (DigIn 12)) [-05] = Bus / IOE Dig In1 (Bus IO In Bit 4 + DI 1 of the first SK xU4-IOE (DigIn 05)) [-06] = Bus / IOE Dig In2 (Bus IO In Bit 5 + DI 2 of the first SK xU4-IOE (DigIn 06)) [-07] = Bus / IOE Dig In3 (Bus IO In Bit 6 + DI 3 of the first SK xU4-IOE (DigIn 07)) [-08] = Bus / IOE Dig In4 (Bus IO In Bit 7 + DI 4 of the first SK xU4-IOE (DigIn 08)) [-09] = Flag 1 ¹⁾ [-10] = Flag 2 ¹⁾ [-11] = Bit 8 BUS control word [-12] = Bit 9 BUS control word</p> <p>The possible functions for the bus In bits can be found in the table of functions for the digital inputs in parameter (P420). Functions {14} "Remote control" and {29} "Enable SetpointBox" are not possible.</p>				

1) The flag function is only possible with control via control terminals.

P481	[-01]	Function BusIO Out Bits		
	...	<i>(Function of Bus I/O Out Bits)</i>		
	[-10]			
<p>0 ... 40</p> <p>{ [-01] = 18 }</p> <p>{ [-02] = 08 }</p> <p>{ [-03] = 30 }</p> <p>{ [-04] = 31 }</p> <p>{ [-05...-10] = 00 }</p>				
<p>The bus I/O Out bits are perceived as multi-function relay outputs. They can be set to the same functions (P434). With devices with in integrated AS interface, the I/O bits can be used by the interface itself (bit 0 ... 3) or in combination with I/O extensions (SK xU4-IOE) (bits 4 ... 5 and flags 1 ... 2).</p> <p>[-01] = Bus / AS-i Dig Out1 (Bus IO Out Bit 0 + AS-i 1) [-02] = Bus / AS-i Dig Out2 (Bus IO Out Bit 1 + AS-i 2) [-03] = Bus / AS-i Dig Out3 (Bus IO Out Bit 2 + AS-i 3) [-04] = Bus / AS-i Dig Out4 (Bus IO Out Bit 3 + AS-i 4) [-05] = Bus / IOE Dig Out1 (Bus IO Out Bit 4 + DO 1 of the first SK xU4-IOE (DigOut 02)) [-06] = Bus / IOE Dig Out2 (Bus IO Out Bit 5 + DO 2 of the first SK xU4-IOE (DigOut 03)) [-07] = Bus / 2nd IOE Dig Out1 (Flag1 ¹⁾ + DO 1 of the second SK xU4-IOE (DigOut 04)) [-08] = Bus / 2nd IOE Dig Out2 (Flag2 ¹⁾ + DO 2 of the second SK xU4-IOE (DigOut 05)) [-09] = Bit 10 BUS status word [-10] = Bit 13 BUS status word</p> <p>The possible functions for the Bus Out Bits can be found in the table of functions for the digital outputs (P434).</p>				

1) The flag function is only possible with control via control terminals.

P480 ... P481 Use of the marker

With the aid of the marker it is possible to define simple logical sequences of functions. For this, the “trigger” of a function is defined in the arrays [-07] “Flag 1” and [-08] “Flag 2” (e.g. an overtemperature warning from the motor PTC) of parameter P481. The function which the frequency inverter is to perform if the “trigger” is active is assigned in arrays [-09] and [-10] of parameter P480. I.e. parameter P480 determines the response of the frequency inverter.

Example:

In an application, the frequency inverter is to reduce the actual speed immediately (e.g. with an active fixed frequency) if the motor is in the overtemperature range (“Overtemp. motor PTC”). This is to be implemented by “Deactivation of analog input 1” via the setpoint used in this example.

This is to ensure that the load on the motor drops and the temperature can stabilise again, and that the drive systematically reduces its speed to a defined amount before a fault shutdown occurs.

Step	Description	Function
1	Specify trigger Set Flag 1 to function “Motor overtemperature warning”	P481 [-07] → Function “12”
2	Specify the response Set Flag 1 to the function “Setpoint 1 on/off	P480 [-09] → Function “19”

Depending on the function selected in (P481) the function must be inverted by adjusting the scaling (P482).

P482	[-01] ... [-10]	Standard BusIO Out Bits (Standardisation of Bus I/O Out Bits)		S	
-------------	------------------------	---	--	----------	--

-400 ... 400 %
{ all 100 }

Adjustment of the limit values of the bus Out bits. For a negative value, the output function will be output negative.
Once the limit value is reached and positive values are delivered, the output produces a High signal, for negative setting values a Low signal.

[-01] = Bus / AS-i Dig Out1	(Bus IO Out Bit 0 + AS-i 1)
[-02] = Bus / AS-i Dig Out2	(Bus IO Out Bit 1 + AS-i 2)
[-03] = Bus / AS-i Dig Out3	(Bus IO Out Bit 2 + AS-i 3)
[-04] = Bus / AS-i Dig Out4	(Bus IO Out Bit 3 + AS-i 4)
[-05] = Bus / IOE Dig Out1	(Bus IO Out Bit 4 + DO 1 of the first SK xU4-IOE (DigOut 02))
[-06] = Bus / IOE Dig Out2	(Bus IO Out Bit 5 + DO 2 of the first SK xU4-IOE (DigOut 03))
[-07] = Bus / 2nd IOE Dig Out1	(Flag1 + DO 1 of the second SK xU4-IOE (DigOut 04))
[-08] = Bus / 2nd IOE Dig Out2	(Flag2 + DO 2 of the second SK xU4-IOE (DigOut 05))
[-09] = Bit 10 BUS status word	
[-10] = Bit 13 BUS status word	

P483	[-01]	Hyst. BusIO Out Bits		S	
	...	<i>(Hysteresis of Bus I/O Out Bits)</i>			
	[-10]				
1 ... 100 % { all 10 }		Difference between switch-on and switch-off point to prevent oscillation of the output signal.			
		[-01] = Bus / AS-i Dig Out1	(Bus IO Out Bit 0 + AS-i 1)		
		[-02] = Bus / AS-i Dig Out2	(Bus IO Out Bit 1 + AS-i 2)		
		[-03] = Bus / AS-i Dig Out3	(Bus IO Out Bit 2 + AS-i 3)		
		[-04] = Bus / AS-i Dig Out4	(Bus IO Out Bit 3 + AS-i 4)		
		[-05] = Bus / IOE Dig Out1	(Bus IO Out Bit 4 + DO 1 of the first SK xU4-IOE (DigOut 02))		
		[-06] = Bus / IOE Dig Out2	(Bus IO Out Bit 5 + DO 2 of the first SK xU4-IOE (DigOut 03))		
		[-07] = Bus / 2nd IOE Dig Out1	(Flag1 + DO 1 of the second SK xU4-IOE (DigOut 04))		
		[-08] = Bus / 2nd IOE Dig Out2	(Flag2 + DO 2 of the second SK xU4-IOE (DigOut 05))		
		[-09] = Bit 10 BUS status word			
		[-10] = Bit 13 BUS status word			

NOTE: Details for the use of the relevant bus systems can be found in the applicable supplementary bus manual.

5.2.6 Additional parameters

Parameter {factory setting}	Setting value / Description / Note		Supervisor	Parameter set
P501	[-01]	Inverter name		
	...	<i>(Inverter name)</i>		
	[-20]			
A...Z (char) { 0 }		Free input of a designation (name) for the device (max. 20 characters). With this, the frequency inverter can be uniquely identified for setting with NORD CON software or within a network.		

P502	[-01] Value master function ... [-03] (Master function value)		S	P																														
0 ... 57 { all 0 }	Selection of master values of a Master for output to a bus system (see P503). These master values are assigned at the slave via (P546): [-01] = Master value 1 [-02] = Master value 2 [-03] = Master value 3 ----- Selection of possible setting values for master values: <table style="width: 100%; border: none;"> <tr> <td style="width: 33%;">00 = Off</td> <td style="width: 33%;">09 = Error number</td> <td style="width: 33%;">19 = Setpoint frequency Master value</td> </tr> <tr> <td>01 = Actual frequency</td> <td>10 = reserved</td> <td>20 = Setpoint frequency after master value ramp</td> </tr> <tr> <td>02 = Actual speed</td> <td>11 = reserved</td> <td>21 = Actual frequency without master value slip</td> </tr> <tr> <td>03 = Current</td> <td>12 = BusIO Out Bits0-7</td> <td>22 = Speed encoder</td> </tr> <tr> <td>04 = Torque current</td> <td>13 = reserved</td> <td>23 = Actual frequency with slip</td> </tr> <tr> <td>05 = Digital IO status</td> <td>14 = reserved</td> <td>24 = Master value, actual frequency with slip</td> </tr> <tr> <td>06 = reserved</td> <td>15 = reserved</td> <td>53 = Actual value 1 PLC</td> </tr> <tr> <td>07 = reserved</td> <td>16 = reserved</td> <td>54 = Actual value 2 PLC</td> </tr> <tr> <td>08 = Setpoint frequency</td> <td>17 = Value analogue input 1</td> <td>55 = Actual value 3 PLC</td> </tr> <tr> <td></td> <td>18 = Value analogue input 2</td> <td></td> </tr> </table>	00 = Off	09 = Error number	19 = Setpoint frequency Master value	01 = Actual frequency	10 = reserved	20 = Setpoint frequency after master value ramp	02 = Actual speed	11 = reserved	21 = Actual frequency without master value slip	03 = Current	12 = BusIO Out Bits0-7	22 = Speed encoder	04 = Torque current	13 = reserved	23 = Actual frequency with slip	05 = Digital IO status	14 = reserved	24 = Master value, actual frequency with slip	06 = reserved	15 = reserved	53 = Actual value 1 PLC	07 = reserved	16 = reserved	54 = Actual value 2 PLC	08 = Setpoint frequency	17 = Value analogue input 1	55 = Actual value 3 PLC		18 = Value analogue input 2				
00 = Off	09 = Error number	19 = Setpoint frequency Master value																																
01 = Actual frequency	10 = reserved	20 = Setpoint frequency after master value ramp																																
02 = Actual speed	11 = reserved	21 = Actual frequency without master value slip																																
03 = Current	12 = BusIO Out Bits0-7	22 = Speed encoder																																
04 = Torque current	13 = reserved	23 = Actual frequency with slip																																
05 = Digital IO status	14 = reserved	24 = Master value, actual frequency with slip																																
06 = reserved	15 = reserved	53 = Actual value 1 PLC																																
07 = reserved	16 = reserved	54 = Actual value 2 PLC																																
08 = Setpoint frequency	17 = Value analogue input 1	55 = Actual value 3 PLC																																
	18 = Value analogue input 2																																	
	NOTE: For details regarding the processing of setpoints and actual values, please refer to Section 8.10 "Scaling of set-/actual values".																																	

P503	Master function output (Master function output)		S			
0 ... 3 { 0 }	For master-slave applications this parameter specifies on which bus system the master transmits the control word and the master values (P502) for the slave. On the slave, parameters (P509), (P510), (P546) define the source from which the slave obtains the control word and the master values from the master and how these are to be processed by the slave. Specification of communication mode on the system bus for ParameterBox and NORDCON. <table style="width: 100%; border: none;"> <tr> <td style="width: 50%; vertical-align: top;"> 0 = Off No control word and master value output, If no individual BUS option (e.g. SK xU4-IOE) is connected to the system bus, only the device directly connected to the ParameterBox or NORDCON is visible. 1 = CANopen (system bus) Control word and master values are transferred to the system bus. If no individual bus option (e.g. SK xU4-IOE) is connected to the system bus, only the device directly connected to the ParameterBox or NORDCON is visible. </td> <td style="width: 50%; vertical-align: top;"> 2 = System bus active No control word and master value output, All FIs connected to the system bus are visible in the ParameterBox or NORDCON, even if no bus option is connected. Prerequisite: all FIs must be set to this mode. 3 = CANopen + system bus active Control word and master values are transferred to the system bus All FIs connected to the system bus are visible in the ParameterBox or NORDCON, even if no bus option is connected. Prerequisite: all other FIs must be set to mode { 2 } "System bus active" </td> </tr> </table>	0 = Off No control word and master value output, If no individual BUS option (e.g. SK xU4-IOE) is connected to the system bus, only the device directly connected to the ParameterBox or NORDCON is visible. 1 = CANopen (system bus) Control word and master values are transferred to the system bus. If no individual bus option (e.g. SK xU4-IOE) is connected to the system bus, only the device directly connected to the ParameterBox or NORDCON is visible.	2 = System bus active No control word and master value output, All FIs connected to the system bus are visible in the ParameterBox or NORDCON, even if no bus option is connected. Prerequisite: all FIs must be set to this mode. 3 = CANopen + system bus active Control word and master values are transferred to the system bus All FIs connected to the system bus are visible in the ParameterBox or NORDCON, even if no bus option is connected. Prerequisite: all other FIs must be set to mode { 2 } "System bus active"			
0 = Off No control word and master value output, If no individual BUS option (e.g. SK xU4-IOE) is connected to the system bus, only the device directly connected to the ParameterBox or NORDCON is visible. 1 = CANopen (system bus) Control word and master values are transferred to the system bus. If no individual bus option (e.g. SK xU4-IOE) is connected to the system bus, only the device directly connected to the ParameterBox or NORDCON is visible.	2 = System bus active No control word and master value output, All FIs connected to the system bus are visible in the ParameterBox or NORDCON, even if no bus option is connected. Prerequisite: all FIs must be set to this mode. 3 = CANopen + system bus active Control word and master values are transferred to the system bus All FIs connected to the system bus are visible in the ParameterBox or NORDCON, even if no bus option is connected. Prerequisite: all other FIs must be set to mode { 2 } "System bus active"					

P504	Pulse frequency (Pulse frequency)		S	
3.0 ... 16.0 kHz { 6.0 }	<p>The internal pulse frequency for controlling the power unit can be changed with this parameter. A higher setting reduces motor noise, but leads to increased EMC emissions and reduction of the possible motor nominal torque.</p> <p>NOTE: The best possible degree of interference suppression for the device is adhered to by using the default value and taking the wiring directives into consideration.</p> <p>NOTE: Raising the pulse frequency leads to a reduction of the possible output current, depending on the time (I^2t curve). When the temperature warning limit (C001) is reached, the pulse frequency is gradually lowered to the default value. If the inverter temperature drops by a sufficient amount, the pulse frequency is increased to the original value.</p>			
P505	Absolute mini. freq. (Absolute minimum frequency)		S	P
0.0 ... 10.0 Hz { 2.0 }	<p>Specifies the frequency value that cannot be undershot by the FI. If the setpoint becomes smaller than the abs. minimum frequency, the FI switches off or changes to 0.0 Hz.</p> <p>At the absolute minimum frequency, brake control (P434) and setpoint delay (P107) are executed. If a setting value of "Zero" is selected, the brake relay does not switch during reversing.</p> <p>In case of encoder-less drives for lifting gear applications, this value should be set to a minimum of 2 Hz. With 2 Hz and higher, the current control of the FI operates and a connected motor can supply sufficient torque.</p> <p>NOTE: Output frequencies < 4.5 Hz result in current limitation (see chapter 8.4.3 "Reduced overcurrent due to output frequency").</p>			
P506	Automatic error acknowledgement (Automatic error acknowledgement)		S	
0 ... 7 { 0 }	<p>In addition to the manual error acknowledgement, an automatic one can also be selected.</p> <p>0 = No automatic error acknowledgement.</p> <p>1 ... 5 = Number of permissible automatic error acknowledgements within one mains-on cycle. After mains off and switch on again, the full amount is again available.</p> <p>6 = Always: an error message will always be acknowledged automatically if the cause of the error is no longer present.</p> <p>7 = Via Deactivate enable: acknowledgement is only possible using the OK / ENTER key or by mains switch-off. No acknowledgement is implemented by removing the enable!</p> <p>NOTE: If (P428) is parameterised to "ON", parameter (P506) "Automatic error acknowledgement" must not be parameterised to setting 6 "Always" as otherwise the device or system is endangered due to the possibility of continuous restarting in the case of an active error (e.g. short-circuit to earth / short circuit).</p>			

P513	Telegram downtime (Telegram downtime)		S	
-0.1 / 0.0 / 0.1 ... 100.0 sec { 0.0 }	<p>If the frequency inverter is directly controlled via the CAN protocol or via RS485, this communication path can be monitored via parameter (P513). Following receipt of a valid telegram, the next one must arrive within the set period. Otherwise the FI reports a fault and switches off with the error message E010 >Bus Time Out<.</p> <p>The inverter monitors the system bus communication via parameter (P120). Therefore parameter (P513) must usually be left in the factory setting {0.0}. Parameter (P513) must only be set to {-0,1} if faults detected by the optional module (e.g. communication errors on the field bus level) are not to result in the drive unit being switched off.</p> <p>0.0 = off: Monitoring is switched off.</p> <p>-0.1 = No error: Even if the bus module detects an error, this does not cause the frequency inverter to be switched off.</p> <p>0.1 ... = On: Monitoring is activated.</p>			
<p>NOTE: The process data channels for USS, CAN/CANopen and CANopen Broadcast are monitoring independently of each other. The decision concerning which channel to monitor is made by means of the setting in parameters P509 and P510.</p> <p>For example, in this way it is possible to register the interruption of a CAN Broadcast communication, although the FI is still communicating with a Master via CAN.</p>				
P514	CAN baud rate (CAN baud rate)		S	
0 ... 7 { 5 }	<p>Setting of the transfer rate (transfer speed) via the system bus interface. All bus participants must have the same baud rate setting.</p> <p>Note: Optional modules (SK xU4-...) only operate with a transfer rate of 250kBaud. Therefore the frequency inverter must remain at the factory setting (250kBaud).</p> <p>0 = 10 kBaud 3 = 100 kBaud 6 = 500 kBaud 1 = 20 kBaud 4 = 125 kBaud 7 = 1 MBaud * (test purposes only) 2 = 50 kBaud 5 = 250 kBaud</p>			
<p style="text-align: right;">*) Reliable operation cannot be guaranteed</p>				
P515	[-01] CAN address ... [-03] (CAN address (system bus))		S	
0 ... 255 _{dec} { all 32 _{dec} } or { all 20 _{hex} }	<p>Setting of the system bus address.</p> <p>[-01] = Slave address, Receive address for system bus [-02] = Broadcast slave address, system bus reception address (slave) [-03] = Master address, "Broadcast master address", transmission address for system bus (master)</p>			
<p>NOTE: If up to four FI are to be linked via the system bus, the addresses must be set as follows → FI 1 = 32, FI 2 = 34, FI 3 = 36, FI 4 = 38.</p> <p>The system bus addresses should be set via DIP switches (chapter 4.3.2.2).</p>				
P516	Skip frequency 1 (Skip frequency 1)		S	P
0.0 ... 400.0 Hz { 0.0 }	<p>The output frequency around the frequency value (P517) set here is not shown.</p> <p>This range is transmitted with the set brake and acceleration ramp; it cannot be continuously supplied to the output. Frequencies below the absolute minimum frequency should not be set.</p> <p>0 = Skip frequency inactive</p>			

P517	Skip freq. area 1 (Skip frequency area 1)		S	P
0.0 ... 50.0 Hz { 2.0 }	Skip range for the >Skip frequency 1< P516. This frequency value is added and subtracted from the skip frequency. Skip frequency range 1: P516 - P517 ... P516 + P517			
P518	Skip frequency 2 (Skip frequency 2)		S	P
0.0 ... 400.0 Hz { 0.0 }	The output frequency around the set frequency value (P519) is skipped. This range is transmitted with the set brake and acceleration ramp; it cannot be continuously supplied to the output. Frequencies below the absolute minimum frequency should not be set. 0 = Skip frequency inactive			
P519	Skip freq. area 2 (Skip frequency area 2)		S	P
0.0 ... 50.0 Hz { 2.0 }	Skip range for the >Skip frequency 2< P518. This frequency value is added and subtracted from the skip frequency. Skip frequency range 2: P518 - P519 ... P518 + P519			
P520	Flying start (Flying start)		S	P
0 ... 4 { 0 }	This function is required to connect the FI to already rotating motors, e.g. in fan drives. Motor frequencies >100Hz are only picked up in speed controlled mode (Servo mode P300 = ON). 0 = Switched off, no flying start. 1 = Both directions, the FI looks for a speed in both directions. 2 = Setpoint value direction, searches only in the direction of the setpoint val. which is present. 3 = Both directions after failure, as for { 1 }, however only after mains failure or fault 4 = Setpoint direction after fail, as for { 2 }, however only after mains failure or fault NOTE: For physical reasons, the flying start circuit only operates above 1/10 of the nominal motor frequency (P201), however, not below 10Hz.			
		Example 1	Example 2	
	(P201)	50Hz	200Hz	
	f=1/10*(P201)	f=5Hz	f=20Hz	
	Comparison of f with f_{min} with: $f_{min} = 10\text{Hz}$	5Hz < 10Hz	20Hz < 10Hz	
	Result f_{Fang}=	The flying start circuit functions above $f_{Fang}=10\text{Hz}$.	The flying start circuit functions above $f_{Fang}=20\text{Hz}$.	
P521	Fly. start resol. (Flying start resolution)		S	P
0.02... 2.50 Hz { 0.05 }	Using this parameter, the flying start circuit search increment size can be adjusted. Values that are too large affect accuracy and causes the FI to cut out with an overcurrent message. If the values are too small, the search time is greatly extended.			
P522	Fly. start offset (Flying start offset)		S	P
-10.0 ... 10.0 Hz { 0.0 }	A frequency value that can be added to the frequency value found, e.g. to remain in the motor range and so avoid the generator range and therefore the chopper range.			

P523		Factory setting (Factory setting)			
0 ... 3 { 0 }		<p>With the selection of the relevant value and confirmation via the ENTER key, the selected parameter range is set to factory setting. Once this setting is made, the parameter value automatically changes back to 0.</p> <p>0 = No change: Does not change the parameterisation.</p> <p>1 = Load factory setting: The complete parameterisation of the FI reverts to the factory setting. All originally parameterised data are lost.</p> <p>2 = Factory setting without bus: All parameters of the frequency inverter, with the <u>exception</u> of the bus parameters, are reset to the factory setting.</p> <p>3 = Factory setting without motor data: All parameters of the frequency inverter, with the <u>exception</u> of the motor data parameters (P201 ... P209), are reset to the factory setting.</p>			
P525	[-01] ... [-03]	Load control max (Load monitoring maximum value)		S	P
1 ... 400 % / 401 { all 401 }		<p>Selection of up to 3 auxiliary values:</p> <p>[-01] = Auxiliary value 1 [-02] = Auxiliary value 2 [-03] = Auxiliary value 3</p> <hr/> <p>Maximum load torque value.</p> <p>Setting of the upper limit of load monitoring. Up to 3 values can be specified. Prefixes are not taken into account, only the integer values are processed (motor / generator torque, right/left rotation). The array elements [-01], [-02] and [-03] of parameters (P525) ... (P527), or the entries which are made there always belong together.</p> <p>401 = OFF Means that the function is switched off. No monitoring is performed. This is also the basic setting for the FI.</p>			
P526	[-01] ... [-03]	Load control min (Load monitoring, minimum value)		S	P
0 ... 400 % { all 0 }		<p>Selection of up to 3 auxiliary values:</p> <p>[-01] = Auxiliary value 1 [-02] = Auxiliary value 2 [-03] = Auxiliary value 3</p> <hr/> <p>Minimum load torque.</p> <p>Setting of the lower limit value of load monitoring. Up to 3 values can be specified. Prefixes are not taken into account, only the integer values are processed (motor / generator torque, right/left rotation). The array elements [-01], [-02] and [-03] of parameters (P525) ... (P527), or the entries which are made there always belong together.</p> <p>0 = OFF Means that the function is switched off. No monitoring is performed. This is also the basic setting for the FI.</p>			
P527	[-01] ... [-03]	Load control freq. (Load monitoring frequency)		S	P
0.0 ... 400.0 Hz { all 25.0 }		<p>Selection of up to 3 auxiliary values:</p> <p>[-01] = Auxiliary value 1 [-02] = Auxiliary value 2 [-03] = Auxiliary value 3</p> <hr/> <p>Auxiliary frequency values</p> <p>Definition of up to 3 frequency points, which define the monitoring range for load monitoring. The auxiliary frequency values do not need to be entered in order of size. Prefixes are not taken into account, only the integer values are processed (motor / generator torque, right/left rotation). The array elements [-01], [-02] and [-03] of parameters (P525) ... (P527), or the entries which are made there always belong together.</p>			

P528	Load control delay <i>(Load monitoring delay)</i>		S	P
0.10 ... 320.00 s { 2.00 }	Parameter (P528) defines the delay time for which an error message ("E12.5") is suppressed on infringement of the defined monitoring range ((P525) ... (P527)). A warning ("C12.5") is triggered after half of this time has elapsed. According to the selected monitoring mode (P529) an error message can also be generally suppressed.			
P529	Mode Load control <i>(Load monitoring mode)</i>		S	P
0 ... 3 { 0 }	The reaction of the frequency inverter to an infringement of the defined monitoring range ((P525) ... (P527)) after the elapse of the delay time (P528) is specified by parameter (P529). 0 = Fault and warning , After the elapse of the time defined in (P528), an infringement of the monitoring range produces a fault ("E12.5"). A warning ("C12.5") is given after the elapse of half of this time. 1 = Warning , After the elapse of half of the time defined in (P528) and infringement of the monitoring range produces a warning ("C12.5"). 2 = Error and warning, constant travel , "Error and warning during constant travel", as for setting "0" however monitoring is inactive during acceleration phases. 3 = Warning constant travel , "Only warning during constant travel", as for setting "1", however monitoring is inactive during acceleration phases.			

P525 ... P529 Load monitoring

With the load monitoring, a range can be specified within which the load torque may change depending on the output frequency. There are three auxiliary values for the maximum permissible torque and three auxiliary values for the minimum permissible torque. A frequency is assigned to each of these auxiliary values. No monitoring is carried out below the first and above the third frequency. In addition, the monitoring can be deactivated for minimum and maximum values. As standard, monitoring is deactivated.

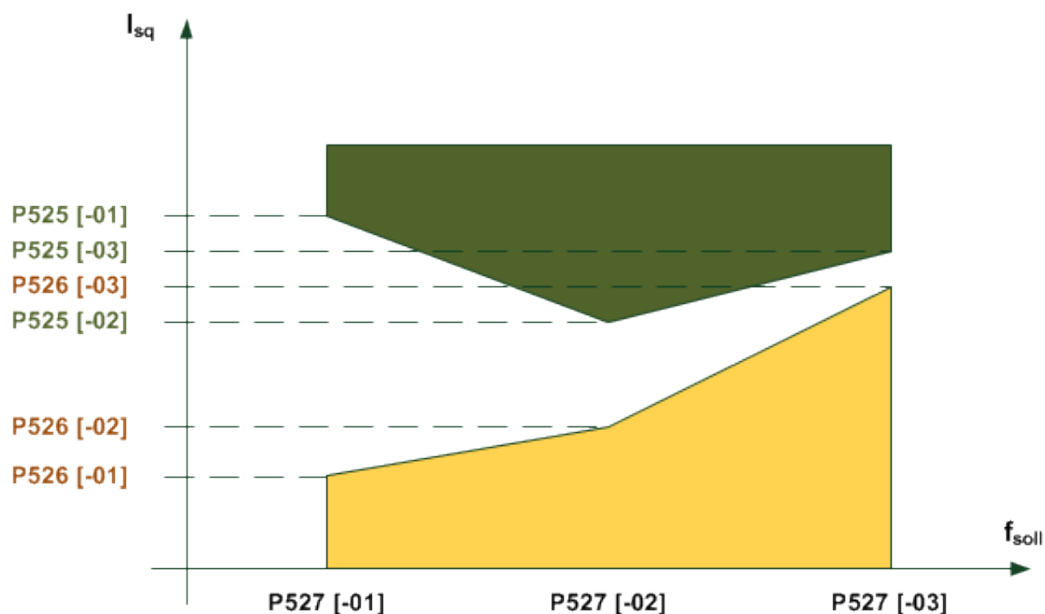

The time after which a fault is triggered can be set with parameter (P528). If the permissible range is exceeded (Example diagram: Infringement of the area marked in yellow or green), the error message **E12.5** is generated unless parameter (P529) does not suppress the triggering of an error.

A warning **C12.5** is always given after the elapse of half of the set error triggering time (P528). This also applies if a mode is selected for which no fault message is generated. If only a maximum or minimum value is to be monitored, the other limit must be deactivated or must remain deactivated. The torque current and not the calculated torque is used as the reference value. This has the advantage that monitoring in the "non field weakened range" without servo mode is usually more accurate. Naturally however, it cannot display more than the physical torque in the weakened field range.

All parameters depend on parameter sets. No differentiation is made between motor and generator torque, therefore the value of the torque is considered. As well as this, there is no differentiation between "left" and "right" running. The monitoring is therefore independent of the prefix of the frequency. There are four different load monitoring modes (P529).

The frequencies, and the minimum and maximum values belong together within the various array elements. The frequencies do not need to be sorted according to their magnitude in the elements 0, 1 and 2, as the frequency inverter does this automatically.

P533	Factor I²t-Motor (Factor I ² t-Motor)		S	
50 ... 150 % { 100 }	The motor current for the I ² t motor monitoring P535 can be weighted with the parameter P533. Larger factors permit larger currents.			
P534	Torque disconn. limit [-01] (Torque disconnection limit) [-02]		S	P
0 ... 400 % / 401 { all 401 }	Via this parameter both the drive [-01] and the generator [-02] switch-off value can be adjusted. If 80% of the set value is reached, a warning status is set. At 100% switch-off is performed with an error message. Error 12.1 is given on exceeding the drive switch-off limit and 12.2 on exceeding the generator switch-off limit.			

[01] = drive switch-off limit

[02] = generator switch-off limit

401 = OFF means that this function has been disabled.

P535	I²t motor (I ² t motor)		
-------------	---	--	--

0 ... 24
{ 0 }

The motor temperature is calculated depending on the output current, the time and the output frequency (cooling). If the temperature limit value is reached, a switch-off occurs with error message E002 (motor overheating). Possible positive or negative acting ambient conditions cannot be taken into account here.

The I²t motor function can be set in a differentiated manner. Eight characteristic curves with three different triggering times (< 5 s, < 10 s and < 20 s) can be set. The triggering times are based on classes 5, 10 and 20 for semiconductor switching devices. The recommended setting for standard applications is P535=5.

All curves run from 0 Hz to half of the nominal frequency (P201). The full nominal current is available from half of the nominal frequency upwards.

With multi-motor operation, the monitoring must be disabled.

I²t- motor off: Monitoring is inactive

Switch-off class 5, 60 s at (1.5 x I _N x P533)		Switch-off class 10, 120 s at (1.5 x I _N x P533)		Switch-off class 20, 240 s at (1.5 x I _N x P533)	
I _N at 0 Hz	P535	I _N at 0 Hz	P535	I _N at 0 Hz	P535
100%	1	100%	9	100%	17
90%	2	90%	10	90%	18
80%	3	80%	11	80%	19
70%	4	70%	12	70%	20
60%	5	60%	13	60%	21
50%	6	50%	14	50%	22
40%	7	40%	15	40%	23
30%	8	30%	16	30%	24

NOTE: Switch-off classes 10 and 20 are provided for applications with heavy starting. When using these switch-off classes, it must be ensured that the FI has a sufficiently high overload capacity.

P536	Current limit (Current limit)		S
-------------	---	--	----------

0.1 ... 2.0 / 2.1
(x nominal FI current)
{ 1.5 }

The inverter output current is limited to the set value. If this limit value is reached, the inverter reduces the actual output frequency.

With the analogue input function in P400 = 13/14, this limit value can also be varied and cause an error message (E12.4).

0.1 ... 2.0 = Multiplier with the inverter nominal current, gives the limit value.

2.1 = OFF means that this limit value is disabled. The FI supplies the maximum possible current.

P537	Pulse disconnection <i>(Pulse disconnection)</i>		S	
10 ... 200 % / 201 { 150 }	<p>This function prevents rapid shutdown of the FI according to the load. With the pulse switch-off enabled, the output current is limited to the set value. This limitation is implemented by brief switching off of individual output stage transistors, the actual output frequency remains unchanged.</p> <p>10...200 % = Limit value in relation to nominal FI current</p> <p>201 = The function is so to speak disabled, the FI supplies the maximum possible current. However, at the current limit the pulse switch-off can still be active.</p> <p>NOTE: The value set here can be undershot by a smaller value in P536. With smaller output frequencies (<4.5 Hz) or higher pulse frequencies (>6 kHz or 8 kHz, P504) the pulse switch-off can be undershot by the power reduction (see chapter 8.4.1 "Increased heat dissipation due to pulse frequency").</p> <p>NOTE: If the pulse switch-off is disabled (P537=201) and a high pulse frequency is selected in parameter P504, the FI automatically reduces the pulse frequency when the power limit is reached. If the load on the FI is reduced again, the pulse frequency increases back to the original value.</p>			
P539	Output monitoring <i>(Output monitoring)</i>		S	P
0 ... 3 { 0 }	<p>This protective function monitors the output current at the U-V-W terminals and checks for plausibility. In cases of error, the error message E016 is output.</p> <p>0 = Disabled: Monitoring is not active.</p> <p>1 = Only motor phases: The output current is measured and checked for symmetry. If an imbalance is present, the FI switches off and outputs the error message E016.</p> <p>2 = Only magnetisation: At the moment the FI is switched on, the level of the excitation current (field current) is checked. If insufficient excitation current is present, the FI switches off with the error message E016. A motor brake is not released in this phase.</p> <p>3 = Motor phase + Magnet: Monitoring of the motor phases and magnetisation as in 1 and 2 are combined.</p> <p>NOTE: This function can be used as an additional protective function for lifting applications, but is not permissible on its own as protection for persons.</p>			

P542	[-01] Set analogue output [-02] (Set analogue output)		S																											
0.0 ... 10.0 V { all 0.0 } only with SK CU4-IOE or SK TU4-IOE	[-01] = First IOE, AOUT of the first I/O extension (SK xU4IOE) [-02] = Second IOE, AOUT of the second I/O extension (SK xU4IOE) The analogue output of the FI can be set with this function, independently of the actual operating state. To do this, the relevant analogue output must be set to the function "External control" (P418 = 7). This function can either be used manually or in combination with a bus control. The value set here will, once confirmed, be produced at the analogue output. Changes which are made to the settings are not saved in the EEPROM. After "Power ON" of the frequency inverter, the parameter is therefore in the default setting.																													
P543	[-01] Actual bus value 1 ... 3 ... [-03] (Actual bus value 1 ... 3)		S	P																										
0 ... 55 { [-01] = 1 } { [-02] = 4 } { [-03] = 9 }	The return status value can be selected for bus actuation in this parameter. NOTE: For further details, please refer to the relevant bus manual or the description for (P418). (Values from 0% ... 100% correspond to 0000 _{hex} ... 4000 _{hex}) For standardisation of the actual values: (see chapter 8.10 "Scaling of set-/actual values").																													
	[-01] = Actual bus value 1 [-02] = Actual bus value 2 [-03] = Actual bus value 3																													
	(Definition of frequencies (see chapter 8.11 "Definition of set and actual value processing (frequencies)"))																													
	<table border="0"> <tr> <td>0 = Off</td> <td>18 = Value of analogue input 2, Analogue input 2 (P400[-02]),</td> </tr> <tr> <td>1 = Actual frequency</td> <td>19 = Setpoint frequency master value (P503)</td> </tr> <tr> <td>2 = Actual speed</td> <td>20 = Target frequency aft. mast. val. ramp, "Setpoint frequency after master value ramp"</td> </tr> <tr> <td>3 = Current</td> <td>21 = Actual freq. without slip Master value "Actual frequency without master value slip"</td> </tr> <tr> <td>4 = Torque current (100% = P112)</td> <td>22 = Reserved</td> </tr> <tr> <td>5 = Digital IO* status</td> <td>23 = Actual frequency with slip (from software version V1.3) "Actual frequency with slip"</td> </tr> <tr> <td>6 = ... 7 Reserved</td> <td>24 = Master value Actual freq. w. slip (SW 1.3 and above) "Master value, actual freq. with slip"</td> </tr> <tr> <td>8 = Setpoint frequency</td> <td>53 = Actual value 1 PLC</td> </tr> <tr> <td>9 = Error number</td> <td>54 = Actual value 2 PLC</td> </tr> <tr> <td>10 = ... 11 Reserved</td> <td>55 = Actual value 3 PLC</td> </tr> <tr> <td>12 = BusIO Out Bits 0-7</td> <td></td> </tr> <tr> <td>13 = ... 16 Reserved</td> <td></td> </tr> <tr> <td>17 = Value analogue input 1, Analogue input 1 (P400[-01]),</td> <td></td> </tr> </table>	0 = Off	18 = Value of analogue input 2, Analogue input 2 (P400[-02]),	1 = Actual frequency	19 = Setpoint frequency master value (P503)	2 = Actual speed	20 = Target frequency aft. mast. val. ramp, "Setpoint frequency after master value ramp"	3 = Current	21 = Actual freq. without slip Master value "Actual frequency without master value slip"	4 = Torque current (100% = P112)	22 = Reserved	5 = Digital IO* status	23 = Actual frequency with slip (from software version V1.3) "Actual frequency with slip"	6 = ... 7 Reserved	24 = Master value Actual freq. w. slip (SW 1.3 and above) "Master value, actual freq. with slip"	8 = Setpoint frequency	53 = Actual value 1 PLC	9 = Error number	54 = Actual value 2 PLC	10 = ... 11 Reserved	55 = Actual value 3 PLC	12 = BusIO Out Bits 0-7		13 = ... 16 Reserved		17 = Value analogue input 1, Analogue input 1 (P400[-01]),				
0 = Off	18 = Value of analogue input 2, Analogue input 2 (P400[-02]),																													
1 = Actual frequency	19 = Setpoint frequency master value (P503)																													
2 = Actual speed	20 = Target frequency aft. mast. val. ramp, "Setpoint frequency after master value ramp"																													
3 = Current	21 = Actual freq. without slip Master value "Actual frequency without master value slip"																													
4 = Torque current (100% = P112)	22 = Reserved																													
5 = Digital IO* status	23 = Actual frequency with slip (from software version V1.3) "Actual frequency with slip"																													
6 = ... 7 Reserved	24 = Master value Actual freq. w. slip (SW 1.3 and above) "Master value, actual freq. with slip"																													
8 = Setpoint frequency	53 = Actual value 1 PLC																													
9 = Error number	54 = Actual value 2 PLC																													
10 = ... 11 Reserved	55 = Actual value 3 PLC																													
12 = BusIO Out Bits 0-7																														
13 = ... 16 Reserved																														
17 = Value analogue input 1, Analogue input 1 (P400[-01]),																														

* assignment of the digital inputs for P543 = 5

Bit 0 = DigIn 1 (FI)	Bit 1 = DigIn 2 (FI)	Bit 2 = DigIn 3 (FI)	Bit 3 = DigIn 4 (FI)
Bit 4 = DigIn 5 (FI)	Bit 5 = PTC input [FI]	Bit 6 = reserved	Bit 7 = reserved
Bit 8 = DigIn 6 (DI1, 1. SK...IOE)	Bit 9 = DigIn 7 (DI2, 1. SK...IOE)	Bit 10 = DigIn 8 (DI3, 1. SK...IOE)	Bit 11 = DigIn 9 (DI4, 1. SK...IOE)
Bit 12 = DigOut 1 (FI)	Bit 13 = DigOut 2 (FI)	Bit 14 = reserved	Bit 15 = reserved

P546	[-01] Function Bus setpoint ... [-03] <i>(Function of bus setpoint)</i>		S	P		
0 ... 32 { [-01] = 1 } { [-02] = 0 } { [-03] = 0 }	<p>In this parameter, a function is allocated to the output setpoint during bus actuation.</p> <p>NOTE: For further details, please refer to the relevant bus manual or the description for (P400). (Values from 0 % ... 100 % correspond to 0000_{hex} ... 4000_{hex}.) For standardisation of the setpoint values: (see chapter 8.10 "Scaling of set-/actual values").</p>					
[-01] = Bus setpoint value 1 [-02] = Bus setpoint value 2 [-03] = Bus setpoint value 3						
Possible values which can be set:						
<table style="width: 100%; border: none;"> <tr> <td style="width: 50%; vertical-align: top;"> 0 = Off 1 = Setpoint frequency (16 bit) 2 = Frequency addition 3 = Frequency subtraction 4 = Minimum frequency 5 = Maximum frequency 6 = Process controller actual value 7 = Process controller setpoint 8 = Actual frequency PI 9 = Actual freq. PI limited 10 = Actual freq. PI monitored 11 = Torque current limit, "<i>Torque current limited</i>" 12 = Torque current switch-off, "<i>Torque current switch-off limit</i>" </td> <td style="width: 50%; vertical-align: top;"> 13 = Current limit, "<i>Current limited</i>" 14 = Current Switch-off "<i>Current switch-off limit</i>" 15 = Ramp time, (P102/103) 16 = Lead torque, ((P214) multiplication) 17 = Multiplication 18 = Curve travel calculator 19 = Servo mode torque 20 = BusIO InBits 0-7 21 = ...25 reserved 31 = Digital output IOE, sets the state of DOUT of the first IOE 32 = Analogue output IOE, sets the value AOUT of the first IOE), condition: P418 = Function "31" Value must be between 0 and 100 (0_{hex} and 64_{hex}). Otherwise the minimum value is output at the analogue output. </td> </tr> </table>					0 = Off 1 = Setpoint frequency (16 bit) 2 = Frequency addition 3 = Frequency subtraction 4 = Minimum frequency 5 = Maximum frequency 6 = Process controller actual value 7 = Process controller setpoint 8 = Actual frequency PI 9 = Actual freq. PI limited 10 = Actual freq. PI monitored 11 = Torque current limit, " <i>Torque current limited</i> " 12 = Torque current switch-off, " <i>Torque current switch-off limit</i> "	13 = Current limit, " <i>Current limited</i> " 14 = Current Switch-off " <i>Current switch-off limit</i> " 15 = Ramp time, (P102/103) 16 = Lead torque, ((P214) multiplication) 17 = Multiplication 18 = Curve travel calculator 19 = Servo mode torque 20 = BusIO InBits 0-7 21 = ...25 reserved 31 = Digital output IOE, sets the state of DOUT of the first IOE 32 = Analogue output IOE, sets the value AOUT of the first IOE), condition: P418 = Function "31" Value must be between 0 and 100 (0 _{hex} and 64 _{hex}). Otherwise the minimum value is output at the analogue output.
0 = Off 1 = Setpoint frequency (16 bit) 2 = Frequency addition 3 = Frequency subtraction 4 = Minimum frequency 5 = Maximum frequency 6 = Process controller actual value 7 = Process controller setpoint 8 = Actual frequency PI 9 = Actual freq. PI limited 10 = Actual freq. PI monitored 11 = Torque current limit, " <i>Torque current limited</i> " 12 = Torque current switch-off, " <i>Torque current switch-off limit</i> "	13 = Current limit, " <i>Current limited</i> " 14 = Current Switch-off " <i>Current switch-off limit</i> " 15 = Ramp time, (P102/103) 16 = Lead torque, ((P214) multiplication) 17 = Multiplication 18 = Curve travel calculator 19 = Servo mode torque 20 = BusIO InBits 0-7 21 = ...25 reserved 31 = Digital output IOE, sets the state of DOUT of the first IOE 32 = Analogue output IOE, sets the value AOUT of the first IOE), condition: P418 = Function "31" Value must be between 0 and 100 (0 _{hex} and 64 _{hex}). Otherwise the minimum value is output at the analogue output.					
P549	PotentiometerBox function <i>(PotentiometerBox function)</i>		S			

0 ... 16
 { 0 }

This parameter provides the possibility of adding a correction value (fixed frequency, analogue, bus) to the current setpoint value by means of the SimpleBox/ParameterBox keyboard. The adjustment range is determined by the auxiliary setpoint value P410/411.

0 = Off 1 = Setpoint frequency , with(P509)≠ 1 control via USS is possible	2 = Frequency addition 3 = Frequency subtraction
--	---

P552	[-01] CAN Master cycle [-02] (CAN Master cycle time)		S	
-------------	---	--	----------	--

0.0 / 0.1 ... 100.0 ms
{ all 0.0 }

In this parameter, the cycle time for the system bus master mode and the CAN open encoder is set (see P503/514/515):

[01] = CAN Master function, Cycle time for system bus master functions

[02] = CANopen Abs. encoder, "CANopen absolute encoder", system bus cycle time of absolute encoder

With the setting **0 = "Auto"** the default value (see table) is used.

According to the Baud rate set, there are different minimum values for the actual cycle time:

Baud rate	Minimum value tz	Default CAN Master	Default CANopen Abs.
10kBaud	10ms	50ms	20ms
20kBaud	10ms	25ms	20ms
50kBaud	5ms	10ms	10ms
100kBaud	2ms	5ms	5ms
125kBaud	2ms	5ms	5ms
250kBaud	1ms	5ms	2ms
500kBaud	1ms	5ms	2ms
1000kBaud:	1ms	5ms	2ms

P553	[-01] PLC setpoints ... [-03] (PLC setpoints)		S	P
-------------	---	--	----------	----------

0 ... 36
all = { 0 }

The PLC setpoints are assigned with a function in this parameter. The settings only apply for main setpoints and with active PLC actuation ((P350) = "On") and ((P351) = "0" or "1").

[-01] = Bus setpoint value 1 ... **[-03] = Bus setpoint 3**

Possible values which can be set:

- | | |
|---|--|
| 0 = Off | 17 = Multiplication |
| 1 = Setpoint frequency | 18 = Curve travel calculator |
| 2 = Frequency addition | 19 = Servo mode torque |
| 3 = Frequency subtraction | 20 = BusIO In Bits 0-7 |
| 4 = Minimum frequency | 21 = Setpoint position Low word |
| 5 = Maximum frequency | 22 = Setpoint pos. HighWord |
| 6 = Process controller actual value | 23 = Setpoint pos. Inc.LowWord |
| 7 = Process controller setpoint | 24 = Target pos.Inc.HighWord |
| 8 = Actual frequency PI | 25 = Gear ratio factor |
| 9 = Actual PI freq. limited | 26 = ... 30: Reserved |
| 10 = Actual PI freq. monitored | 31 = Digital output IOE |
| 11 = Torque current limit (limiting) | 32 = Analog output IOE |
| 12 = Torque current switch-off limit | 33 = Torque process controller setpoint |
| 13 = Current limit (limiting) | 34 = d-correction F process |
| 14 = Current switch-off limit | 35 = d-correction Torque |
| 15 = Ramp time | 36 = d-correction F+Torque |
| 16 = Torque precontrol | |

P555	Chopper P limitation (Chopper power limitation)		S	
5 ... 100 % { 100 }	<p>With this parameter it is possible to program a manual (peak) power limit for the brake resistor. The switch-on delay (modulation level) for the chopper can only rise to a certain maximum specified limit. Once this value has been reached, irrespective of the level of the link voltage, the inverter switches off the current to the resistor.</p> <p>The result would be an overvoltage switch-off of the FI.</p> <p>The correct percentage value is calculated as follows: $k[\%] = \frac{R * P_{\max BW}}{U_{\max}^2} * 100\%$</p> <p>R = Resistance of the brake resistor P_{maxBW} = Momentary peak power of the brake resistor U_{max} = FI chopper switching threshold</p> <p>1~ 115/230 V ⇒ 440 V= 3~ 230 V ⇒ 440 V= 3~ 400 V ⇒ 840 V=</p> <p>NOTE: This parameter is only relevant for size 2.</p>			
P556	Braking resistor (Brake resistor)		S	
20 ... 400 Ω { 120 }	<p>Value of the brake resistance for the calculation of the maximum brake power to protect the resistor.</p> <p>Once the maximum continuous output (P557) including overload (200 % for 60 s) is reached, an I²t limit error (E003.1) is triggered. Further details in (P737).</p> <p>NOTE: This parameter is only relevant for size 2.</p>			
P557	Brake resistor type (Brake resistor power)		S	
0.00 ... 20.00 kW { 0.00 }	<p>Continuous power (nominal power) of the resistor, to display the actual utilisation in (P737). For a correctly calculated value, the correct value must be entered into (P556) and (P557).</p> <p>0.00 = Monitoring disabled</p> <p>NOTE: This parameter is only relevant for size 2.</p>			
P558	Flux delay (Flux delay)		S	P
0 / 1 / 2 ... 5000 ms { 1 }	<p>The ISD control can only function correctly if there is a magnetic field in the motor. For this reason, a DC current is applied before starting the motor to provide the excitation of the stator winding. The duration depends on the size of the motor and is automatically set in the factory setting of the FI.</p> <p>For time-critical applications, the magnetizing time can be set or deactivated.</p> <p>0 = Disabled 1 = Automatic calculation 2 ... 5000 = Time set in [ms]</p> <p>NOTE: Setting values that are too low can reduce the dynamics and starting torque.</p>			

P559	DC Run-on time (DC run-on time)		S	P
0.00 ... 30.00 s { 0.50 }	<p>After a stop signal and elapse of the brake ramp, direct current is applied to the motor for a short time. This should completely shut down the drive. Depending on the inertia, the time of current application can be set in this parameter.</p> <p>The current level depends on the previous braking procedure (current vector control) or the static boost (linear characteristic curve).</p> <p>Note: This function is not possible in closed-loop mode with PMSM!</p>			

P560	Parameter, Saving mode (Saving mode parameter)		S	
0 ... 2 { 1 }	<p>0 = Only in RAM, changes to the parameter settings are no longer saved on the EEPROM. All previously saved settings are retained, even if the FI is disconnected from the mains.</p> <p>1 = RAM and EEPROM, all parameter changes are automatically written to the EEPROM and remain stored there even if the FI is disconnected from the mains supply.</p> <p>2 = OFF, no saving in RAM and EEPROM possible (no parameter changes are accepted)</p> <p>NOTE: If BUS communication is used to implement parameter changes, it must be ensured that the maximum number of write cycles (100,000 x) in the EEPROM is not exceeded.</p>			

5.2.7 Information

Parameter	Setting value / Description / Note		Supervisor	Parameter set
P700	Actual operating status (Actual operating status)			
0.0 ... 25.4	<p>Display of current messages for the present operating status of the frequency inverter such as faults, warnings or the reason why switch-on is disabled (see chapter 6 "Operating status messages").</p> <p>[-01] = Present fault, shows the currently active (unacknowledged) fault (see section "Error messages").</p> <p>[-02] = Present warning, indicates a current warning message (see section "Warning messages").</p> <p>[-03] = Reason for disabled starting, indicates the reason for an active start disable (see section "Switch-on block messages").</p> <p>NOTE</p> <p><i>SimpleBox / ControlBox:</i> the error numbers of the warning messages and faults can be displayed using SimpleBox and ControlBox.</p> <p><i>ParameterBox:</i> with the ParameterBox the messages are displayed in plain text.. In addition, the reason for a possible disabling of starting can also be displayed.</p> <p><i>Bus:</i> The display of bus-level error messages is displayed in decimal integer format. The displayed value must be divided by 10 in order to correspond with the correct format.</p> <p>Example: Display: 20 → Error number: 2.0</p>			

P701	[-01] Last fault 1 ... 5 ... [-05] <i>(Last fault 1...5)</i>			
0.0 ... 25.4	This parameter stores the last 5 faults (see section "Error messages"). The SimpleBox / ControlBox must be used to select the corresponding memory location 1...5- (Array parameter), and confirmed using the OK / ENTER key to read the stored error code.			
P702	[-01] Last frequency error ... [-05] <i>(Last frequency error 1...5)</i>		S	
-400.0 ... 400.0 Hz	This parameter stores the output frequency that was being delivered at the time the fault occurred. The values of the last 5 errors are stored. The SimpleBox / ControlBox must be used to select the corresponding memory location 1...5- (Array parameter), and confirmed using the OK- / ENTER key to read the stored error code.			
P703	[-01] Current last error ... [-05] <i>(Last current error 1...5)</i>		S	
0.0 ... 999.9 A	This parameter stores the output current that was being delivered at the time the fault occurred. The values of the last 5 errors are stored. The SimpleBox / ControlBox must be used to select the corresponding memory location 1...5- (Array parameter), and confirmed using the OK / ENTER key to read the stored error code.			
P704	[-01] Volt. last error ... [-05] <i>(Last voltage error 1...5)</i>		S	
0 ... 600 V AC	This parameter stores the output voltage that was being delivered at the time the fault occurred. The values of the last 5 errors are stored. The SimpleBox / ControlBox must be used to select the corresponding memory location 1...5- (Array parameter), and confirmed using the OK / ENTER key to read the stored error code.			
P705	[-01] Last link circuit error ... [-05] <i>(Last link circuit error 1...5)</i>		S	
0 ... 1000 V DC	This parameter stores the link voltage that was being delivered at the time the error occurred. The values of the last 5 errors are stored. The SimpleBox / ControlBox must be used to select the corresponding memory location 1...5- (Array parameter), and confirmed using the OK / ENTER key to read the stored error code.			

P706 [-01] ... [-05]	P set last error <i>(Parameter set last error 1 ... 5)</i>		S																																	
0 ... 3	This parameter saves the number of the parameter set that was active when the error occurred. Data for the previous 5 errors is saved. With the SimpleBox/ControlBox, the respective memory slot 1 ... 5 (array parameters) must be selected and confirmed with the OK/ENTER key to read the saved error code.																																			
P707 [-01] ... [-03]	Software-Version <i>(Software version/ revision)</i>																																			
0.0 ... 9999.9	This parameter shows the software and revision numbers in the FI. This can be significant when different FIs are assigned the same settings. Array 03 provides information about any special versions of the hardware or software A zero stands for the standard version.																																			
P708	Status of digital input <i>(Status of digital input)</i>																																			
00000 ... 11111 (bin) or 0000 ... FFFF (hex)	Displays the status of the digital inputs in binary/hexadecimal code. This display can be used to check the input signals. Bit 0 = Digital input 1 Bit 1 = Digital input 2 Bit 2 = Digital input 3 Bit 3 = Digital input 4 Bit 4 = Digital input 5 Bit 5 = Thermistor input Bits 6 - 7 reserved																																			
	<table border="0" style="width: 100%;"> <tr> <td style="width: 50%; vertical-align: top;"> <u>First SK xU4-IOE (optional)</u> Bit 8 = 1: IO extension: Digital input 1 Bit 9 = 1: IO extension: Digital input 2 Bit 10 = 1: IO extension: Digital input 3 Bit 11 = 1: IO extension: Digital input 4 </td> <td style="width: 50%; vertical-align: top;"> <u>Second SK xU4-IOE (optional)</u> Bit 12 = 2: IO extension: Digital input 1 Bit 13 = 2: IO extension: Digital input 2 Bit 14 = 2: IO extension: Digital input 3 Bit 15 = 2: IO extension: Digital input 4 </td> </tr> </table> <table border="1" style="width: 100%; border-collapse: collapse; text-align: center;"> <thead> <tr> <th></th> <th>Bits 15-12</th> <th>Bits 11-8</th> <th>Bits 7-4</th> <th>Bits 3-0</th> <th></th> </tr> </thead> <tbody> <tr> <td>Minimum value</td> <td>0000</td> <td>0000</td> <td>0000</td> <td>0000</td> <td>Binary</td> </tr> <tr> <td></td> <td>0</td> <td>0</td> <td>0</td> <td>0</td> <td>hex</td> </tr> <tr> <td>Maximum value</td> <td>1111</td> <td>1111</td> <td>1111</td> <td>1111</td> <td>Binary</td> </tr> <tr> <td></td> <td>F</td> <td>F</td> <td>F</td> <td>F</td> <td>hex</td> </tr> </tbody> </table>				<u>First SK xU4-IOE (optional)</u> Bit 8 = 1: IO extension: Digital input 1 Bit 9 = 1: IO extension: Digital input 2 Bit 10 = 1: IO extension: Digital input 3 Bit 11 = 1: IO extension: Digital input 4	<u>Second SK xU4-IOE (optional)</u> Bit 12 = 2: IO extension: Digital input 1 Bit 13 = 2: IO extension: Digital input 2 Bit 14 = 2: IO extension: Digital input 3 Bit 15 = 2: IO extension: Digital input 4		Bits 15-12	Bits 11-8	Bits 7-4	Bits 3-0		Minimum value	0000	0000	0000	0000	Binary		0	0	0	0	hex	Maximum value	1111	1111	1111	1111	Binary		F	F	F	F	hex
<u>First SK xU4-IOE (optional)</u> Bit 8 = 1: IO extension: Digital input 1 Bit 9 = 1: IO extension: Digital input 2 Bit 10 = 1: IO extension: Digital input 3 Bit 11 = 1: IO extension: Digital input 4	<u>Second SK xU4-IOE (optional)</u> Bit 12 = 2: IO extension: Digital input 1 Bit 13 = 2: IO extension: Digital input 2 Bit 14 = 2: IO extension: Digital input 3 Bit 15 = 2: IO extension: Digital input 4																																			
	Bits 15-12	Bits 11-8	Bits 7-4	Bits 3-0																																
Minimum value	0000	0000	0000	0000	Binary																															
	0	0	0	0	hex																															
Maximum value	1111	1111	1111	1111	Binary																															
	F	F	F	F	hex																															
	SimpleBox: The binary bits are converted to a hexadecimal value and displayed. ParameterBox: The Bits are displayed increasing from right to left (binary).																																			
P709 [-01] ... [-07]	Analog input voltage <i>(Voltage analogue input)</i>																																			
-100 ... 100 %	Displays the measured analogue input value. [-01] = Analogue input 1 , function of analogue input 1 integrated into the FI [-02] = Analogue input 2 , function of analogue input 2 integrated into the FI [-03] = Ext. analogue input 1 , AIN 1 of the <u>first</u> I/O extension SK xU4-IOE [-04] = Ext. analogue input 2 , AIN2 of the <u>first</u> I/O extension SK xU4-IOE [-05] = Ext. A.in. 1 2nd IOE , "External analogue input 1 2nd IOE", AIN1 of the <u>second</u> I/O extension (SK xU4-IOE) (= Analogue input 3) [-06] = Ext. A.in. 2 2nd IOE , "External analogue input 2 2nd IOE", AIN2 of the <u>second</u> I/O extension (SK xU4-IOE) (= Analogue input 4) [-07] = Setpoint module , SK SSS-3A, see BU0040																																			

P710	[-01] [-02]	Analogue output volt. <i>(Analogue output voltage)</i>			
0.0 ... 10.0 V	Displays the delivered value of analogue output. [-01] = First IOE , AOUT of the <u>first</u> I/O extension (SK xU4-IOE) [-02] = Second IOE , AOUT of the <u>second</u> I/O extension (SK xU4-IOE)				
P711		State of relays <i>(state of digital outputs)</i>			
00000 ... 11111 (bin) or 00 ... FF (hex)	Indicates the actual status of the digital outputs of the frequency inverter. Bit 0 = Digital output 1 Bit 1 = Digital output 2 Bit 2 = reserved Bit 3 = reserved Bit 4 = Digital output 1, IO extension 1 Bit 5 = Digital output 2, IO extension 1 Bit 6 = Digital output 1, IO extension 2 Bit 7 = Digital output 2, IO extension 2				
			Bits 7-4	Bits 3-0	
Minimum value			0000 0	0000 0	Binary hex
Maximum value			1111 F	1111 F	Binary hex
SimpleBox: The binary bits are converted to a hexadecimal value and displayed.					
ParameterBox: The bits are displayed increasing from right to left (binary).					
P714		Operating time <i>(Operating time)</i>			
0.10 ... ___ h	This parameter shows the time for which the FI was connected to the mains and was ready for operation.				
P715		Running time <i>(Enablement time)</i>			
0.00 ... ___ h	This parameter shows the time for which the FI was enabled and supplied current to the output.				

P716	Current frequency (Actual frequency)			
-400.0 ... 400.0 Hz	Displays the actual output frequency.			
P717	Current speed (Actual rotation speed)			
-9999 ... 9999 rpm	Displays the actual motor speed calculated by the FI.			
P718	Present Actual setpoint frequency (Actual setpoint frequency)			
-400.0 ... 400.0 Hz	Displays the frequency specified by the setpoint (see chapter 8.1 "Setpoint processing"). [-01] = Actual setpoint frequency from the setpoint source [-02] = Actual setpoint frequency after processing in the FI status machine [-03] = Actual setpoint frequency after frequency ramp			
P719	Actual current (Actual current)			
0.0 ... 999.9 A	Displays the actual output current.			
P720	Act. torque current (Actual torque current)			
-999.9 ... 999.9 A	Displays the actual calculated torque-developing output current (active current). Basis for calculation are the motor data P201...P209. → negative values = generator, → positive values = drive			
P721	Actual field current (Actual field current)			
-999.9 ... 999.9 A	Displays the actual calculated field current (reactive current). Basis for calculation are the motor data P201...P209.			
P722	Current voltage (Actual voltage)			
0 ... 500 V	Displays the actual AC voltage supplied by the FI output.			
P723	Voltage -d (Actual voltage component U_d)		S	
-500 ... 500 V	Displays the actual field voltage component.			
P724	Voltage -q (Actual voltage component U_q)		S	
-500 ... 500 V	Displays the actual torque voltage component.			

P725	Current Cos phi <i>(Actual cosj)</i>			
0.00 ... 1.00	Displays the actual calculated cos φ of the drive.			
P726	Apparent power <i>(Apparent power)</i>			
0.00 ... 300.00 kVA	Displays the actual calculated apparent power. The basis for calculation are the motor data P201...P209.			
P727	Mechanical power <i>(Mechanical power)</i>			
-99.99 ... 99.99 kW	Displays the actual calculated effective power of the motor. Basis for calculation are the motor data P201...P209.			
P728	Input voltage <i>(mains voltage)</i>			
0 ... 1000 V	Displays the actual mains voltage at the FI input. This is directly determined from the amount of the intermediate circuit voltage			
P729	Torque <i>(Torque)</i>			
-400 ... 400 %	Displays the actual calculated torque. Basis for calculation are the motor data P201...P209.			
P730	Field <i>(Field)</i>			
0 ... 100 %	Displays the actual field in the motor calculated by the FI. The basis for calculation are the motor data P201...P209.			
P731	Parameter set <i>(Actual parameter set)</i>			
0 ... 3	Shows the actual operating parameter set.			
	0 = Parameter set 1		2 = Parameter set 3	
	1 = Parameter set 2		3 = Parameter set 4	
P732	Phase U current <i>(U phase current)</i>		S	
0.0 ... 999.9 A	Displays the actual U phase current.			
	NOTE: This value can deviate somewhat from the value in P719, due to the measurement procedure used, even with symmetrical output currents.			

P733		Phase V current (V phase current)		S	
0.0 ... 999.9 A		Displays the actual V phase current. NOTE: This value can deviate somewhat from the value in P719, due to the measurement procedure used, even with symmetrical output currents.			
P734		Phase W current (W phase current)		S	
0.0 ... 999.9 A		Displays the actual W phase current. NOTE: This value can deviate somewhat from the value in P719, due to the measurement procedure used, even with symmetrical output currents.			
P735		reserved		S	
P736		D.c. link voltage (DC link voltage)			
0 ... 1000 V DC		Displays the actual link voltage.			
P737		Usage rate brakeres. (Actual brake resistor usage rate)			
0 ... 1000 %		<p>This parameter provides information about the actual degree of modulation of the brake chopper or the current utilisation of the braking resistor in generator mode.</p> <p>If parameters P556 and P557 are correctly set, the utilisation related to P557, the resistor power, is displayed.</p> <p>If only P556 is correctly set (P557=0), the degree of modulation of the brake chopper is displayed. Here, 100 means that the brake resistor is fully switched. On the other hand, 0 means that the brake chopper is not active at present.</p> <p>If P556 = 0 and P557 = 0, this parameter also provides information about the degree of modulation of the brake chopper in the FI.</p> <p>NOTE: This parameter is only relevant for size 2.</p>			
P738	[-01] [-02]	Motor usage rate (current motor usage rate)			
0 ... 1000 %		<p>Shows the actual motor load. Basis for calculation is the motor data P203. The actually recorded current is related to the nominal motor current.</p> <p>[-01] = in relation to I_N (P203) of the motor [-02] = in relation to I^2t monitoring, "in relation to I^2t monitoring" (P535)</p>			
P739	[-01] ... [-03]	Heatsink temperature (Present heat sink temperature)			
-40 ... 150 °C		<p>[-01] = Heat sink temperature of FI [-02] = Ambient temperature of FI [-03] = Temp. Motor KTY, motor temperature via KTY</p>			

P740	[-01] ... [-17]	PZD bus In <i>(Process data Bus In)</i>	S
0000 ... FFFF (hex)	<p>This parameter provides information about the actual control word and the setpoints that are transferred via the bus systems.</p> <p>For display, a BUS system must be selected in P509.</p> <p>Standardisation: (📖 section (see chapter 8.10 "Scaling of set-/actual values"))</p>	<p>[-01] = Control word</p> <p>[-02] = Setpoint 1 (P510/1, P546) [-03] = Setpoint 2 (P510/1, ...) [-04] = Setpoint 3 (P510/1, ...)</p> <p>[-05] = res.status InBit P480</p> <p>[-06] = Parameter data In 1 [-07] = Parameter data In 2 [-08] = Parameter data In 3 [-09] = Parameter data In 4 [-10] = Parameter data In 5</p> <p>[-11] = Setpoint 1 (P510/2) [-12] = Setpoint 2 (P510/2) [-13] = Setpoint 3 (P510/2)</p> <p>[-14] = Control word PLC [-15] = Setpoint 1 PLC ... [-17] = Setpoint 3 PLC</p>	<p>Control word, source from P509.</p> <p>Setpoint data from main setpoint (P510 [-01]).</p> <p>The displayed value depicts all Bus In Bit sources linked with an "OR".</p> <p>Data during parameter transfer: Order label (AK), Parameter number (PNU), Index (IND), Parameter value (PWE 1/2)</p> <p>Setpoint data from the master function value (Broadcast) - (P502/P503), if P509 = 4</p> <p>Control word + Setpoint data from PLC</p>
P741	[-01] ... [-17]	PZD bus Out <i>(Process data Bus Out)</i>	S
0000 ... FFFF (hex)	<p>This parameter provides information about the actual status word and the actual values that are transferred via the bus systems.</p> <p>Standardisation: (📖 section (see chapter 8.10 "Scaling of set-/actual values"))</p>	<p>[-01] = Status word</p> <p>[-02] = Actual value 1 (P543) [-03] = Actual value 2 (...) [-04] = Actual value 3 (...)</p> <p>[-05] = res.status OutBit P481</p> <p>[-06] = Parameter data Out 1 [-07] = Parameter data Out 2 [-08] = Parameter data Out 3 [-09] = Parameter data Out 4 [-10] = Parameter data Out 5</p> <p>[-11] = Actual value 1 master funct. [-12] = Actual value 2 master funct. [-13] = Actual value 3 master funct.</p> <p>[-14] = Status word PLC [-15] = Actual value 1 PLC ... [-17] = Actual value 3 PLC</p>	<p>Status word, source from P509.</p> <p>Actual values</p> <p>The displayed value depicts all Bus OUT Bit sources linked with an "OR".</p> <p>Data during parameter transfer.</p> <p>Actual value of master function P502 / P503.</p> <p>Status word + Actual values to PLC</p>

P742	Data base version <i>(Database version)</i>		S	
0 ... 9999	Displays the internal database version of the FI.			
P743	Inverter type <i>(Inverter type)</i>			
0.00 ... 250.00	Displays the inverter power in kW, e.g. "1.50" ⇒ FI with 1.5 kW nominal power.			
P744	Configuration level <i>(Configuration level)</i>			
0000 ... FFFF (hex)	This parameter displays the special devices integrated in the FI. Display is in hexadecimal code (SimpleBox, Bus System). The display is in plain text when the ParameterBox is used.			
	High byte:		Low byte:	
	00 _{hex} No extension		00 _{hex} Standard I/O	(SK 180E)
	01 _{hex} reserved		01 _{hex} AS-i	(SK 190E)
	02 _{hex} reserved		02 _{hex} --	
P746	Module status <i>(Operating status of module)</i>	SK 190E		
0000 ... 0111 (bin) or 00 ... 07 (hex)	Displays the current operating status of the AS interface. Bit 0 = AS interface voltage is present Bit 1 = AS interface watchdog set to active by master Bit 2 = AS interface connected			
	SimpleBox: The binary bits are converted to a hexadecimal value and displayed. ParameterBox: The bits are displayed increasing from right to left (binary).			
P747	Inverter Volt. Range <i>(Inverter voltage range)</i>			
0 ... 2	Indicates the mains voltage range for which this device is specified. 0 = 100...120V 1 = 200...240V 2 = 380...480V			

P748	CANopen status (CANopen status (system bus status))			
0000 ... FFFF (hex) or 0 ... 65535 (dec)	Shows the status of the system bus.			
	Bit 0:	24V Bus supply voltage		
	Bit 1:	CANbus in "Bus Warning" status		
	Bit 2:	CANbus in "Bus Off" status		
	Bit 3:	System bus → Bus module online (field bus module, e.g.: SK xU4-PBR)		
	Bit 4:	System bus → Additional module 1 online (I/O - module, e.g.: SK xU4-IOE)		
	Bit 5:	System bus → Additional module 2 online (I/O - module, e.g.: SK xU4-IOE)		
	Bit 6:	The protocol of the CAN module is 0 = CAN / 1 = CANopen		
	Bit 7:	Vacant		
	Bit 8:	"Bootup Message" sent		
	Bit 9:	CANopen NMT State		
	Bit 10:	CANopen NMT State		
		CANopen NMT State	Bit 10	Bit 9
		Stopped	0	0
		Pre- Operational	0	1
		Operational	1	0
P749	Status of DIP switches (Status of DIP switches)			
0000 ... 0007 (hex) or 0 ... 007 (dec)	This parameter shows the actual setting of the FI DIP switch "S2" (See BU0200)(see chapter 4.3.2.2 "DIP switches (S1, S2)").			
	Bit 0:	DIP switch 1		
	Bit 1:	DIP switch 2		
	Bit 2:	DIP switch 3		
P750	Stat. overcurrent (Overcurrent statistics)		S	
0 ... 9999	Number of overcurrent messages during the operating period P714.			
P751	Stat. Overvoltage (Overvoltage statistics)		S	
0 ... 9999	Number of overvoltage messages during the operating period P714.			
P752	Stat. mains failure (Mains failure statistics)		S	
0 ... 9999	Number of mains faults during the operating period P714.			
P753	Stat. overtemperature (Overheating statistics)		S	
0 ... 9999	Number of overtemperature faults during the operating period P714.			

P754	Stat. parameter lost <i>(Parameter loss statistics)</i>		S	
0 ... 9999	Number of parameters lost during the operating period P714.			
P755	Stat. system error <i>(System fault statistics)</i>		S	
0 ... 9999	Number of system faults during the operating period P714.			
P756	Stat. Timeout <i>(Time out statistics)</i>		S	
0 ... 9999	Number of Time out errors during the operating period P714.			
P757	Stat. Customer error <i>(Customer fault statistics)</i>		S	
0 ... 9999	Number of Customer Watchdog faults during the operating period P714.			
P760	Actual mains current <i>(Actual mains current)</i>		S	
0.0 ... 999.9 A	Displays the actual input current.			
P799	Op.-time last error <i>(Operating time, last fault 1...5)</i>			
0.1 ... ___ h	This parameter shows the operating hours counter status (P714) at the moment of the previous fault. Array 01...05 corresponds to the lastest fault 1...5.			

6 Operating status messages

The device and technology units generate appropriate messages if they deviate from their normal operating status. There is a differentiation between warning and error messages. If the device is in the status "Start disabled", the reason for this can also be displayed.

The messages generated for the device are displayed in the corresponding array of parameter (**P700**). The display of the messages for technology units is described in the respective additional instructions and data sheets for the modules concerned.

Start disabled, "Not Ready" → (P700 [-03])

If the device is in the status "Not Ready" or "Start Disabled", the reason for this is indicated in the third array element of parameter (**P700**).

Display is only possible with the NORD CON software or the ParameterBox.

Warning messages → (P700 [-02])

Warning messages are generated as soon as a defined limit is reached. However this does not cause the frequency inverter to switch off. These messages can be displayed via the array-element [-02] in parameter (**P700**) until either the reason for the warning is no longer present or the frequency inverter has gone into a fault state with an error message.

Error messages → (P700 [-01])

Errors cause the device to switch off, in order to prevent a device fault.

The following options are available to reset a fault (acknowledge):

- Switching the mains off and on again,
- By an appropriately programmed digital input (**P420**),
- By switching off the "enable" on the device (if no digital input is programmed for acknowledgement),
- By Bus acknowledgement

- By (**P506**), automatic error acknowledgement.

6.1 Display of messages

LED indicators

The device status is indicated by integrated status LEDs that are visible from the outside in delivery state. Depending on the device type, this is either a dual-colour LED (DS = Device State) or two single-colour LEDs (DS = Device State, DE = Device Error).

Meaning:

Green indicates operational readiness and the presence of mains voltage. During operation, the degree of overload at the device output is indicated by a faster flashing code.

Red indicates a pending error. The LED flashes with the frequency corresponding to the error group (for example E003 = 3x flashing).

SimpleBox Display

The SimpleBox displays an error with its number and the prefix "E". In addition, the present fault can be displayed in array element [-01] of parameter (**P700**). The last error messages are stored in parameter (**P701**). Further information about the frequency inverter status at the moment of the fault can be obtained from parameters (**P702**) to (**P706**) / (**P799**)

If the cause of the error is no longer present, the error display in the SimpleBox flashes and the error can be acknowledged with the Enter key.

In contrast, warning messages are prefixed with "C" ("Cxxx") and cannot be acknowledged. They disappear automatically when the reason for them is no longer present or the frequency inverter has switched to the "Error" state. Display of the message is suppressed if the warning appears during parameterisation.

The present warning message can be displayed in detail at any time in array element [-02] of parameter (P700).

The reason for an existing disabled switch on cannot be displayed with the SimpleBox.

ParameterBox display

The ParameterBox displays the messages in plain text.

6.2 Diagnostic LEDs on device

The device generates operating status messages. These messages (warnings, errors, switching statuses, measurement data) can be displayed with parametrisation tools (📖 Section 3.1 "Control and parametrisation options ") (Parameter group P7xx).

To a limited extent, the messages are also indicated via the diagnostic and status LEDs.

Diagnostic LEDs

LED			Status signal ¹⁾		Meaning
Name	Colour	Description			
DS	red/green	Device status	Off		Device not ready for operation • No control voltage
			green on		Device ready for operation
			green flashing	0.5 Hz	Device ready for switching on
				4 Hz	Device in switch-on block
			red/green Alternating	4 Hz	Warning
				1..25 Hz	Degree of overload of switched-on device
			green on + red flashing		Device not ready for operation
red flashing		Error, flashing frequency represents error number			
ASi	red/green	Status of AS-i			Details (📖 Section 4.5.4.2 "Displays")

1) Signal status = specification of LED colour + flashing frequency (switch-on frequency per second), example "red flashes, 2 Hz" = red LED switches on and off 2x per second

6.3 Messages

Error messages

Display in the SimpleBox / ControlBox		Fault Text in the ParameterBox	Cause • Remedy
Group	Details in P700 [-01] / P701		
E001	1.0	Overtemp. Inverter <i>"Inverter overtemperature"</i> (inverter heat sink)	Inverter temperature monitoring measurements are outside of the permissible temperature range, i.e. the error is triggered if the permissible lower limit is undershot or the permissible upper temperature limit is exceeded.
	1.1	Overtemp. FI internal <i>"Internal FI overtemperature"</i> (interior of FI)	<ul style="list-style-type: none"> Depending on the cause: Reduce or increase the ambient temperature Check the FI fan / control cabinet ventilation Check the FI for dirt
E002	2.0	Motor overtemp.PTC <i>"Motor overtemperature PTC"</i>	PTC resistor has triggered <ul style="list-style-type: none"> Reduce motor load Increase motor speed Use external motor fan
	2.1	Motor overtemp.I²t <i>"Motor overtemperature I²t"</i> Only if I ² t motor (P535) has been programmed.	Motor I ² t has triggered (calculated motor overtemperature) <ul style="list-style-type: none"> Reduce motor load Increase motor speed
	2.2	Ext Resistor Temp <i>"External braking resistor overtemperature"</i> Overtemperature reported via P420 [...] = {13} or P400 [...] = {30}	Thermostat (e.g. braking resistor) has triggered <ul style="list-style-type: none"> Digital input is low Check connections and temperature sensor
E003	3.0	Overcurrent I²t-Lim.	Inverter: I ² t limit has triggered, e.g. > 1.5 x I _n for 60 s (also note P504) <ul style="list-style-type: none"> Continuous overload at FI output Possible encoder fault (resolution, defect, connection)
	3.1	Overcurrent chopper I²t	Brake chopper: I ² t limit has triggered, 1.5 time the value reached for 60 s (also note P554, if available, and P555, P556, P557) <ul style="list-style-type: none"> Avoid overcurrent on braking resistor
	3.2	Overcurrent IGBT 125% monitoring	De-rating (power reduction) <ul style="list-style-type: none"> 220 % Overcurrent Brake chopper current too high For fan drives: enable flying start (P520)
	3.3	Overcurrent IGBTfast 150% monitoring	De-rating (power reduction) <ul style="list-style-type: none"> 230 % Overcurrent Brake chopper current too high
	3.4	Overcurrent chopper	Overcurrent chopper triggering has triggered twice within 50 ms. <ul style="list-style-type: none"> Brake chopper current too high Short circuit, or braking resistance too low

E004	4.0	Overcurrent module	Error signal from module (short duration) <ul style="list-style-type: none"> • Short-circuit or earthing fault at FI output • Motor cable is too long • Use external output choke • Brake resistor faulty or resistance too low → Do not shut off P537! The occurrence of a fault can significantly shorten the service life of the device, or even destroy it.
	4.1	Overcurrent measurement <i>"Overcurrent measurement"</i>	P537 (pulse current switch-off) was reached 3x within 50 ms (only possible if P112 and P536 are disabled) <ul style="list-style-type: none"> • FI is overloaded • Drive sluggish, insufficiently sized • Ramps (P102/P103) too steep -> Increase ramp time • Check motor data (P201 ... P209)
E005	5.0	Overvoltage Ud	Link circuit voltage too high <ul style="list-style-type: none"> • Increase deceleration time (P103) • Possibly set shutdown mode (P108) with delay (not for lifting equipment) • Extend the quick stop time (P426) • Speed fluctuation (for example due to high inertia loads) → if necessary set the <U/f characteristic curve (P211, P212) FIs with brake chopper: <ul style="list-style-type: none"> • Dissipate energy feedback with a braking resistor • Check the function of the braking resistor (cable break) • Resistance of connected braking resistor too high
	5.1	Mains high voltage	Mains voltage too high <ul style="list-style-type: none"> • See Technical Data (📖 Section 7.3 "Electrical data")
E006	---	Reserved	
E007	7.0	Mains Phase Failure	Error at mains connection side <ul style="list-style-type: none"> • A mains phase is not connected • Mains asymmetrical
	7.1	Phasefailure dc-link	DC link voltage too low <ul style="list-style-type: none"> • A mains phase is not connected • Load temporarily too high

6 Operating status messages

E008	8.0	Parameter loss (maximum EEPROM value exceeded)	Error in EEPROM data <ul style="list-style-type: none"> Software version of the stored data set not compatible with the software version of the FI. NOTE: <u>Faulty parameters</u> are automatically reloaded (default data). <ul style="list-style-type: none"> EMC interferences (see also E020)
	8.1	Inverter type incorrect	<ul style="list-style-type: none"> EEPROM faulty
	8.2	Reserved	
	8.3	EEPROM KSE error (Customer unit incorrectly identified (customer's interface equipment))	The upgrade level of the frequency inverter was not correctly identified. <ul style="list-style-type: none"> Switch mains voltage off and on again.
	8.4	Internal EEPROM error (Database version incorrect)	
	8.7	EEPR copy not the same	
E009	---	Reserved	
E010	10.0	Bus Timeout	Telegram time-out / Bus off 24V int. CANbus <ul style="list-style-type: none"> Data transfer is faulty. Check P513. Check physical bus connections Check bus protocol program process. Check Bus Master. Check 24V supply of internal CAN/CANopen Bus. Node guarding error (internal CANopen) <i>Bus Off</i> error (internal CANbus)
	10.2	Bus Timeout Option	Telegram timeout <ul style="list-style-type: none"> Telegram transfer is faulty. Check physical bus connections Check bus protocol program process. Check Bus Master. PLC is in the "STOP" or "ERROR" state.
	10.4	Init error Option	Initialisation error in bus module <ul style="list-style-type: none"> Check Bus module current supply. DIP switch setting of a connected I/O extension module is incorrect
	10.1	System error option	System error bus module <ul style="list-style-type: none"> Further details can be found in the respective additional bus instructions.
	10.3		
	10.5		
	10.6		
10.7		<u>I/O extension:</u> <ul style="list-style-type: none"> Incorrect measurement of the input voltage or undefined provision of the output voltage due to error in reference voltage generation. Short circuit at analogue output 	
10.9	Module missing / P120	The module entered in parameter (P120) is not available. <ul style="list-style-type: none"> Check connections 	

E011	11.0	Customer terminal	<p>A/D converter error</p> <p>Internal control terminal (internal data bus) incorrect or interference due to radio radiation (EMC).</p> <ul style="list-style-type: none"> • Check control connections for short circuit. • Minimise EMC interferences by separate routing of control and power cables. • Earth devices and shields well.
E012	12.0	External watchdog	<p>The Watchdog function is selected at a digital input and the impulse at the corresponding digital input is not present for longer than the time set in parameter P460 >Watchdog time<.</p> <ul style="list-style-type: none"> • Check connections • Check setting P460
	12.1	Limit moto./Customer <i>"Drive switch-off limit"</i>	<p>The drive switch-off limit (P534 [-01]) has triggered.</p> <ul style="list-style-type: none"> • Reduce load on motor • Set higher value in (P534 [-01]).
	12.2	Limit gen. <i>"Generator switch-off limit"</i>	<p>The generator switch-off limit (P534 [-02]) has triggered.</p> <ul style="list-style-type: none"> • Reduce load on motor • Set higher value in (P534 [-02]).
	12.3	Torque limit	<p>Limit from potentiometer or setpoint source has switched off. P400 = 12</p>
	12.4	Current limit	<p>Limit from potentiometer or setpoint source has switched off. P400 = 14</p>
	12.5	Load monitor	<p>Switch-off due to overshooting or undershooting of permissible load torques ((P525) ... (P529)) for the time set in (P528).</p> <ul style="list-style-type: none"> • Adjust load. • Change limit values ((P525) ... (P527)). • Increase delay time (P528). • Change monitoring mode (P529).
	12.8	AI minimum <i>„Analogue In minimum“</i>	<p>Switch-off due to undershooting of the 0% adjustment value (P402) with setting (P401) "0-10V with switch-off on error 1" or "...2"</p>
	12.9	AI maximum <i>„Analogue In maximum“</i>	<p>Switch-off due to overshooting of the 100% adjustment value (P402) with setting (P401) "0-10V with switch-off on error 1" or "...2"</p>
E013	13.2	Shut-down monitoring	<p>The slip error monitoring was triggered; the motor could not follow the setpoint.</p> <ul style="list-style-type: none"> • Check motor data P201-P209! (important for current controllers) • Check motor circuit • Check encoder settings P300 and following in servo mode • Increase setting value for torque limit in P112 • Increase setting value for current limit in P536 • Check deceleration time P103 and extend if necessary
E015	---	Reserved	

6 Operating status messages

E016	16.0	Motor phase error	A motor phase is not connected. <ul style="list-style-type: none"> • Check P539 • Check motor connection
	16.1	Magnetisation current monitoring <i>"Magnetisation current monitoring"</i>	Required exciting current not achieved at moment of switch-on. <ul style="list-style-type: none"> • Check P539 • Check motor connection
E019	19.0	Parameter identification <i>"Parameter identification"</i>	Automatic identification of the connected motor was unsuccessful <ul style="list-style-type: none"> • Check motor connection • Check preset motor data (P201 ... P209) • PMSM – CFC Closed Loop Operation: Rotor position of motor incorrect in relation to incremental encoder Perform determination of rotor position (initial enable after a "Mains on" only with motor stationary (P330)
	19.1	Star / Delta circuit incorrect <i>"Motor star / delta circuit incorrect"</i>	
E020	20.0	Reserved	System error in program execution, triggered by EMC interference. <ul style="list-style-type: none"> • Observe wiring guidelines • Use additional external mains filter. • FI must be very well earthed.
E021	20.1	Watchdog	
	20.2	Stack overflow	
	20.3	Stack underflow	
	20.4	Undefined opcode	
	20.5	Protected Instruct. <i>"Protected Instruction"</i>	
	20.6	Illegal word access	
	20.7	Illegal Inst. Access <i>"Illegal instruction access"</i>	
	20.8	Program memory error <i>"Program memory error"</i> (EEPROM error)	
	20.9	Dual-ported RAM	
	21.0	NMI error (Not used by hardware)	
	21.1	PLL error	
	21.2	ADU error "Overrun"	
	21.3	PMI error "Access Error"	
	21.4	Userstack overflow	
E022	---	Reserved	Error message for PLC → see supplementary instructions BU 0550
E023	---	Reserved	Error message for PLC → see supplementary instructions BU 0550
E024	---	Reserved	Error message for PLC → see supplementary instructions BU 0550

Warning messages

Display in the SimpleBox / ControlBox		Warning Text in the ParameterBox	Cause • Remedy
Group	Details in P700 [-02]		
C001	1.0	Overtemp. Inverter "Inverter overtemperature" (inverter heat sink)	Inverter temperature monitoring Warning: permissible temperature limit reached. <ul style="list-style-type: none"> • Reduce ambient temperature • Check the FI fan / control cabinet ventilation • Check the FI for dirt
C002	2.0	Motor overtemp.PTC "Motor overtemperature PTC"	Warning from the PTC resistor (trigger limit reached) <ul style="list-style-type: none"> • Reduce motor load • Increase motor speed • Use external motor fan
	2.1	Motor overtemp.I²t "Motor overtemperature I ² t" Only if I ² t motor (P535) is programmed.	Warning: I ² t motor monitoring (1.3 x the rated current reached for the time period set in (P535)) <ul style="list-style-type: none"> • Reduce motor load • Increase motor speed
	2.2	Ext Resistor Temp "External braking resistor overtemperature" Overtemperature via digital input (P420 [...]) = {13}	Warning: Temperature sensor (e.g. braking resistor) has triggered <ul style="list-style-type: none"> • Digital input is low
C003	3.0	Overcurrent, I²t limit	Warning: Inverter: I ² t limit has triggered, e.g. > 1.3 x I _n for 60s (please also note P504) <ul style="list-style-type: none"> • Continuous overload at FI output
	3.1	Overcurrent, chopper I²t	Warning: I ² t limit for the brake chopper has triggered, 1.3x value attained for 60s (also note P554, if present, as well as P555, P556, P557) <ul style="list-style-type: none"> • Avoid overload of brake resistance
	3.5	Torque current limit	Warning: Torque current limit reached <ul style="list-style-type: none"> • Check (P112)
	3.6	Current limit	Warning: Current limit reached <ul style="list-style-type: none"> • Check (P536)
C004	4.1	Overcurrent measurement "Overcurrent measurement"	Warning: pulse switch off is active The limit for activation of pulse switch off (P537) has been reached (only possible if P112 and P536 are switched off) <ul style="list-style-type: none"> • FI is overloaded • Drive sluggish, insufficiently sized • Ramps (P102/P103) too steep -> Increase ramp time • Check motor data (P201 ... P209) • Switch off slip compensation (P212)

6 Operating status messages

C008	8.0	Parameter loss	<p>Warning: One of the cyclically saved messages such as <i>operating hours</i> or <i>enabling time</i> could not be saved successfully.</p> <p>The warning disappears as soon as saving can be successfully performed.</p>
C012	12.1	Limit moto./Customer "Drive switch-off limit"	<p>Warning: 80 % of the drive switch-off limit (P534 [-01]) has been exceeded.</p> <ul style="list-style-type: none"> • Reduce load on motor • Set higher value in (P534 [-01]).
	12.2	Limit gen. "Generator switch-off limit"	<p>Warning: 80 % of the generator switch-off limit (P534 [-02]) has been reached.</p> <ul style="list-style-type: none"> • Reduce load on motor • Set higher value in (P534 [-02]).
	12.3	Torque limit	<p>Warning: 80 % of the limit from the potentiometer or the setpoint source has been reached. P400 = 12</p>
	12.4	Current limit	<p>Warning: 80 % of the limit from the potentiometer or the setpoint source has been reached. P400 = 14</p>
	12.5	Load monitor	<p>Warning due to overshooting or undershooting of permissible load torques ((P525) ... (P529)) for the time set in (P528).</p> <ul style="list-style-type: none"> • Adjust load. • Change limit values ((P525) ... (P527)). • Increase delay time (P528).

Switch-on block messages

Display in the SimpleBox / ControlBox		Reason: Text in the ParameterBox	Cause • Remedy
Group	Details in P700 [-03]		
I000	0.1	Disable voltage from IO	If the function "disable voltage" is parameterised, input (P420 / P480) is at Low <ul style="list-style-type: none"> • Set "input High" • Check signal cable (broken cable)
	0.2	IO fast stop	If the function "fast stop" is parameterised, input (P420 / P480) is at Low <ul style="list-style-type: none"> • Set "input High" • Check signal cable (broken cable)
	0.3	Block voltage from bus	<ul style="list-style-type: none"> • For bus operation (P509): control word Bit 1 is "Low"
	0.4	Bus fast stop	<ul style="list-style-type: none"> • For bus operation (P509): control word Bit 2 is "Low"
	0.5	Enable on start	Enable signal (control word, Dig I/O or Bus I/O) was already applied during the initialisation phase (after mains "ON", or control voltage "ON"). Or electrical phase is missing. <ul style="list-style-type: none"> • Only issue enable signal after completion of initialisation (i.e. when the FI is ready) • Activation of "Automatic Start" (P428)
	0.6 – 0.7	Reserved	Information message for PLC → see supplementary instructions
	0.8	Right direction blocked	Switch-on block with inverter shut-off activated by: P540 or by "Enable right block" (P420 = 31, 73) or "Enable left block" (P420 = 32, 74), The frequency inverter switches to "Ready for switching on" status
	0.9	Left direction blocked	
I006 ¹⁾	6.0	Charging error	Charging relay not energised, because: <ul style="list-style-type: none"> • Mains/DC link voltage too low • Mains voltage failure Remedy: <ul style="list-style-type: none"> • Activate "Evacuation mode" ((P420) / (P480))
I011	11.0	Analog Stop	If an analog input of the frequency inverter or a connected IO extension is configured to detect cable breaks (2-10V signal or 4-20mA signal), the frequency inverter switches to the status "ready for switch-on" if the analog signal undershoots the value 1 V or 2 mA This also occurs if the relevant analog input is parameterised to function "0" ("no function"). <ul style="list-style-type: none"> • Check connections

1) Indication of operating mode (message) on the *ParameterBox* or virtual operating unit of the *NORD CON-Software*: "**Not ready**"

6.4 FAQ operational problems

Fault	Possible cause	Remedy
Device will not start (all LEDs off)	<ul style="list-style-type: none"> No mains voltage or wrong mains voltage 	<ul style="list-style-type: none"> Check connections and supply cables Check switches / fuses
Device does not react to enabling	<ul style="list-style-type: none"> Control elements not connected Incorrect control word source setting Right and left enable signals present simultaneously Enable signal present before device ready for operation (device expecting a 0 → 1 edge) 	<ul style="list-style-type: none"> Reset enable Change over P428 if necessary: "0" = device expecting a 0→1 edge for enable / "1" = device reacts to "Level" → Danger: Drive can start up independently! Check control connections Check P509
Motor will not start in spite of enable being present	<ul style="list-style-type: none"> Motor cables not connected Brake not ventilating No setpoint specified Incorrect setpoint source setting 	<ul style="list-style-type: none"> Check connections and supply cables Check control elements Check P510
Device switches off without error message when load increases (increased mechanical load / speed)	<ul style="list-style-type: none"> Mains phase missing 	<ul style="list-style-type: none"> Check connections and supply cables Check switches / fuses
Motor rotates in the wrong direction	<ul style="list-style-type: none"> Motor cable: U-V-W interchanged 	<ul style="list-style-type: none"> Motor cable: Change 2 phases Alternative: <ul style="list-style-type: none"> – Swap Enable right/Enable left functions (P420) – Swap Bit 11/12 control word (for bus control)
Motor not reaching required speed	<ul style="list-style-type: none"> Maximum frequency parameter setting too low 	<ul style="list-style-type: none"> Check P105

<p>Motor speed does not correspond to the setpoint specification</p>	<ul style="list-style-type: none"> • Analogue input function set to "Frequency addition". Another setpoint is present. 	<ul style="list-style-type: none"> • Check P400 • P420, check active fixed frequencies • Check bus setpoints • P104/ P105 Check "Min/ max. –frequency" • P113 Check "Jog frequency"
<p>Intermittent communication error between FI and option modules</p>	<ul style="list-style-type: none"> • System bus terminating resistor not set • Poor connection contacting • Interference on system bus line • Maximum system bus length exceeded 	<ul style="list-style-type: none"> • First and last subscriber only: Set DIP switches for terminating resistance • Check connections • Connect GND of all FI connected to system bus • Pay attention to routing regulations (separate routing of signal and control cables and mains and motor cables) • Check cable lengths (system bus)

Table 12: FAQ operational problems

7 Technical data

7.1 General frequency inverter data

Function	Specification
Output frequency	0.0 ... 400.0 Hz
Pulse frequency	3.0 ... 16.0 kHz, factory setting = 6 kHz Power reduction > 8 kHz with 115 / 230 V device, > 6 kHz with 400 V device
Typical overload capacity	150% for 60 s, 200% for 3.5 s
Efficiency	> 95% depending on the size
Energy efficiency	IE2 (chapter 7.2)
Insulation resistance	> 10 MΩ
Leakage current	<ul style="list-style-type: none"> ≤ 16 mA with standard configuration for operation in TN / TT network The specifications apply to a pulse frequency from 4 to 16 kHz (see also parameter P504)
Operating/ambient temperature	-25 °C ... +40 °C, for detailed information (including UL values) on individual device types and operating modes, see (chapter 7.3). ATEX: -20 ... +40 °C (chapter 2.5)
Storage and transport temperature	-25 °C ... +60/70 °C
Long-term storage	(chapter 9)
Protection class	IP55, optionally IP66 (chapter 1.9) NEMA1, higher NEMA classifications on request
Max. installation altitude above sea level	<i>Up to 1000 m</i> No power reduction <i>1000 ... 2000 m:</i> 1% / 100 m power reduction, overvoltage category 3 <i>2000 ... 4000 m:</i> 1% / 100 m power reduction, overvoltage category 2, external overvoltage protection required at mains input
Ambient conditions	<i>Transport (IEC 60721-3-2):</i> Mechanical: 2M2 <i>Operation (IEC 60721-3-3):</i> Mechanical: 3M7 Climatic: 3K3 (IP55) 3K4 (IP66)
Environmental protection	<i>Energy-saving function</i> (chapter 8.7), see P219 <i>EMC</i> (chapter 8.3) <i>RoHS</i> (chapter 1.6)
Protective measures against	Overtemperature of the frequency inverter Short circuit, earth fault, overload, idling Overvoltage and undervoltage
Motor temperature monitoring	I ² t motor, PTC/bimetallic switch
Regulation and control	Sensorless current vector control (ISD), linear V/f characteristic curve, VFC open-loop, CFC open-loop
Waiting period between two mains switch-on cycles	60 s for all devices in normal operating cycle
Interfaces	<i>Standard</i> RS485 (USS) (for parameterisation units only) RS232 (single slave) System bus <i>Option</i> AS-i – on board (chapter 4.5) Various bus modules (chapter 1.3)
Electrical isolation	Control terminals
Connection terminals, electrical connection	<i>Power unit</i> (chapter 2.4.2) <i>Control unit</i> (chapter 2.4.3)

7.2 Technical data for determining the energy efficiency level

The following tables relate to the provisions of the Ecodesign EU Regulation 2019/1781.

Information

Calculation basis for the energy efficiency level

The energy efficiency specifications come from calculations according to **DIN EN 61800** “Adjustable speed electrical power drive systems – Part 9-2: Ecodesign for power drive systems, motor starters, power electronics and their driven applications – Energy efficiency indicators for power drive systems and motor starters”.

Simplifications are included in the calculation methods of the standard!

Manufact	FI type	Rel. losses ¹⁾ (rel. motor stator frequency / rel. torque-producing current)							Standby ²⁾	Standby ²⁾ (UKCA)	IE rating
		90/100	90/50	50/100	50/50	50/25	0/100	0/50			

Notice: A comma counts as a full stop and signifies a decimal place.

Getriebebau NORD GmbH & Co. KG	NORDAC BASE SK 1x0E-	[%]	[%]	[%]	[%]	[%]	[%]	[%]	[%]	[W]	[%]	
	250-323	4,6	4,0	4,2	3,8	3,7	3,9	3,6	3,6	5,0	2,00	IE2
	370-323	4,0	3,3	3,6	3,1	3,0	3,2	2,9	2,9	5,0	1,35	IE2
	550-323	3,7	2,9	3,2	2,7	2,6	2,9	2,6	2,6	5,0	0,91	IE2
	750-323	3,2	2,4	2,8	2,3	2,2	2,5	2,1	2,1	4,6	0,61	IE2
	111-323	3,2	2,2	2,7	2,0	1,7	2,3	1,8	1,6	4,6	0,42	IE2
	151-323	2,9	1,9	2,4	1,7	1,5	2,1	1,6	1,4	4,6	0,30	IE2
	250-340	6,5	5,7	6,0	5,5	5,4	5,6	5,4	5,4	5,7	2,28	IE2
	370-340	6,0	5,2	5,5	5,0	5,0	5,2	4,9	4,9	5,7	1,53	IE2
	550-340	4,3	3,5	3,8	3,3	3,2	3,5	3,2	3,2	5,5	1,00	IE2
	750-340	3,8	3,0	3,3	2,8	2,7	3,0	2,7	2,7	5,5	0,73	IE2
	111-340	3,6	2,5	3,0	2,3	2,0	2,6	2,2	2,0	5,5	0,50	IE2
	151-340	3,5	2,4	2,9	2,3	2,0	2,6	2,2	2,0	5,1	0,34	IE2
221-340	3,5	2,3	2,8	2,1	1,8	2,5	2,0	1,8	5,1	0,23	IE2	

1) Power losses in % of the rated apparent output power

2) Standby losses in % of the rated output power

Manuf	Fl type	Output power	Indicative output power	Rated output current	Max. operating temperature	Rated input frequency	Rated input voltage range
-------	---------	--------------	-------------------------	----------------------	----------------------------	-----------------------	---------------------------

Notice: A comma counts as a full stop and signifies a decimal place.

Getriebebau NORD GmbH & Co. KG	NORDAC BASE SK 1x0E-	[kVA]	[kW]	[A]	[°C]	[Hz]	[V]
	250-323	0,5	0,25	1,31	40	50	200 V – 240 V
	370-323	0,7	0,37	1,83	40	50	200 V – 240 V
	550-323	1,0	0,55	2,56	40	50	200 V – 240 V
	750-323	1,3	0,75	3,39	40	50	200 V – 240 V
	111-323	1,7	1,10	4,49	40	50	200 V – 240 V
	151-323	2,3	1,50	6,02	40	50	200 V – 240 V
	250-340	0,5	0,25	0,76	40	50	380 V – 480 V
	370-340	0,7	0,37	1,06	40	50	380 V – 480 V
	550-340	1,0	0,55	1,48	40	50	380 V – 480 V
	750-340	1,3	0,75	1,96	40	50	380 V – 480 V
	111-340	1,7	1,10	2,60	40	50	380 V – 480 V
	151-340	2,3	1,50	3,48	40	50	380 V – 480 V
	221-340	3,3	2,20	5,02	40	50	380 V – 480 V

7.3 Electrical data

The following table lists the electrical data for frequency inverters. The details based on measurement series for the operating modes are for orientation purposes and may deviate in practice. The measurement series were made at the rated speed with 4-pole NORD standard motors

The following factors have a particular influence on the determined limiting values:

Wall mounted

- Installation location
- Influence from adjacent devices
- Additional air currents

and also with

Motor Mounted

- Type of motor used,
- Size of motor used
- Speed with internally ventilated motors
- Use of external fans.



Information

Single phase operation

For single phase operation (115 / 230 V) the mains impedance must be at least 100 μ H for each conductor. If this is not the case, a mains choke must be installed.

Failure to comply with this may cause damage to the device due to impermissible currents in the components.



Information

Information about current and power

The powers stated for the operating modes are only a rough categorisation

The current values are more reliable details for the selection of the correct frequency inverter/motor combination!

The following tables contain the data which is relevant for UL(see chapter 1.6.1 "UL and CSA approval").

7.3.1 Electrical data 1~ 115 V

Device type	SK 1x0E...	-250-112-	-370-112-	-550-112-	-750-112-	
	Size	1	1	1	1	
Nominal motor power (4-pole standard motor)	230 V	0.25 kW	0.37 kW	0.55 kW	0.75 kW	
	240 V	1/3 hp	1/2 hp	3/4 hp	1 hp	
Mains voltage	115 V	1 AC 110 ... 120 V, ± 10%, 47 ... 63 Hz				
Input current	rms	9.1 A	11.0 A	14.3 A	18.4 A	
	FLA	9.1 A	11.0 A	14.3 A	18.4 A	
Output voltage	230 V	3 AC 0 ... 2 times mains voltage				
Output current ¹⁾	rms	1.7 A	2.1 A	3.0 A	3.7 A	
	FLA motor mounting	1.7 A	2.1 A	3.0 A (S1-40°C)	3.7 A (S1-40°C)	
	FLA wall mounting	1.7 A	2.1 A	3.0 A (S1-40°C)	3.7 A ^{a)} (S1-20°C)	
Motor-mounted (ventilated)						
Max. continuous power / max. continuous current:						
S1-50°C		0.25 kW / 1.7 A	0.37 kW / 2.1 A	0.55 kW / 2.6 A	0.55 kW / 2.9 A	
S1-40°C		0.25 kW / 1.7 A	0.37 kW / 2.1 A	0.55 kW / 3.0 A	0.75 kW / 3.7 A	
Max. permissible ambient temp. with nominal output current						
S1		50°C	50°C	40°C	40°C	
S3 70% ED 10 min		50°C	50°C	50°C	50°C	
S6 70% ED 10 min (100% / 20% Mn)		50°C	50°C	50°C	50°C	
Wall mounting (unventilated)						
Max. continuous power / max. continuous current						
S1-50°C		0.25 kW / 1.7 A	0.37 kW / 2.1 A	0.55 kW / 3.0 A	0.55 kW / 2.7 A	
S1-40°C		0.25 kW / 1.7 A	0.37 kW / 2.1 A	0.55 kW / 3.0 A	0.75 kW / 3.4 A	
Max. permissible ambient temp. with nominal output current						
S1		50°C	50°C	40°C	35°C	
S3 70% ED 10 min		50°C	50°C	50°C	45°C	
S6 70% ED 10 min (100% / 20% Mn)		50°C	50°C	50°C	45°C	
			General fuses (AC) (recommended)			
slow-blowing		16 A	16 A	16 A	25 A	
		UL fuses (AC) – permitted				
		I _{sc} ²⁾ [A]				
		Class				
		10 000	65 000	100 000		
Fuse ³⁾	RK5	(x)	x	30 A	30 A	30 A
	CC, J, R, T, G, L	(x)	x	30 A	30 A	30 A
CB ⁴⁾	(≥ 115 V)		x	30 A	30 A	30 A

1) FLA motor installation: relates to a motor with fan

2) Maximum permissible mains overload current

3) The use of a SK TU4-MSW(-...) module limits the permissible short circuit current in the mains to 10 kA

4) "inverse time trip type" in accordance with UL 489

a) FLA: 3.4 A (S1-40°C)

7.3.2 Electrical data 1/3~230 V

Device type		SK 1x0E...	-250-323-	-370-323-	-550-323-
		Size	1	1	1
Nominal motor power (4-pole standard motor)		230 V	0.25 kW	0.37 kW	0.55 kW
		240 V	1/3 hp	1/2 hp	3/4 hp
Mains voltage		230 V	1/3 AC 200 ... 240 V, ± 10%, 47 ... 63 Hz		
Input current		rms	4.5 / 3.2 A	5.7 / 3.8 A	7.2 / 4.8 A
		FLA	4.5 / 3.2 A	5.7 / 3.8 A	7.2 / 4.8 A
Output voltage		230 V	3 AC 0 ... Mains voltage		
Output current ¹⁾		rms	1.7 A	2.2 A	3.0 A
		FLA motor mounting	1.7 A	2.2 A (S1-40°C)	2.9 A (S1-40°C)
		FLA wall mounting	1.7 A	2.2 A (S1-40°C)	2.9 A ^{a)} (S1-25°C)
Motor-mounted (ventilated)					
Max. continuous power / max. continuous current					
		S1-50°C	0.25kW / 1.7A	0.37kW / 2.2A	0.37kW / 2.2A
		S1-40°C	0.25kW / 1.7A	0.37kW / 2.2A	0.55kW / 3.0A
Max. permissible ambient temp. with nominal output current					
		S1	50°C	50°C	40°C
		S3 70% ED 10 min	50°C	50°C	50°C
		S6 70% ED 10 min (100% / 20% Mn)	50°C	50°C	50°C
Wall mounting (unventilated)					
Max. continuous power / max. continuous current					
(deviating value for 1~ operation in brackets)		S1-50°C	0.25kW / 1.7A	0.37kW / 2.2A (1.9A)	0.55kW / 3.0A (2.2A)
		S1-40°C	0.25kW / 1.7A	0.37kW / 2.2A	0.55kW / 3.0A (2.5A)
Max. permissible ambient temp. with nominal output current					
		S1	50°C	1~ 40°C / 3~ 50°C	1~ 25°C / 3~ 40°C
		S3 70% ED 10 min	50°C	50°C	1~ 35°C / 3~ 50°C
		S6 70% ED 10 min (100% / 20% Mn)	50°C	50°C	1~ 35°C / 3~ 50°C
			General fuses (AC) (recommended)		
slow-blowing			10 A	10 A	10 A
		Class	UL fuses (AC) – permitted		
			Isc ²⁾ [A]		
			10 000	65 000	100 000
Fuse ³⁾		RK5	(x)	x	10 A
		CC, J, R, T, G, L	(x)	x	10 A
CB ⁴⁾		(≥ 230 V)		x	10 A
					10 A

1) FLA motor installation: relates to a motor with fan

2) Maximum permissible mains overload current

3) The use of a SK TU4-MSW(-...) module limits the permissible short circuit current in the mains to 10 kA

4) "inverse time trip type" in accordance with UL 489

a) FLA: 2.2 A (S1-40°C)

Device type		SK 1x0E...	-750-323-	-111-323-	-151-323-	
		Size	2	2	2	
Nominal motor power (4-pole standard motor)		230 V	0.75 kW	1.10 kW	1.5 kW	
		240 V	1 hp	1½ hp	2 hp	
Mains voltage		230 V	1/3 AC 200 ... 240 V, ± 10%, 47 ... 63 Hz		3 AC	
Input current	rms		10.6 / 7.0 A	14.0 / 9.2 A	11.2 A	
	FLA		10.6 / 7.0 A	14.0 / 9.2 A	11.2 A	
Output voltage		230 V	3 AC 0 ... Mains voltage			
Output current ¹⁾	rms		4.0 A	5.5 A	7.0 A	
	FLA motor mounting		3.9 A (S1-40°C)	5.4 A (S1-40°C)	6.9 A (S1-40°C)	
	FLA wall mounting		3.9 A (S1-40°C)	5.4 A ^{a)} (S1-30°C)	6.9 A (S1-40°C)	
Min. braking resistor	Accessories		100 Ω	100 Ω	75 Ω	
Motor-mounted (ventilated)						
Max. continuous power / max. continuous current:						
(deviating value for 1~ operation in brackets)		S1-50°C	0.75kW / 4.0A (3.4A)	0.75kW / 4.2A	1.1kW / 5.5A	
		S1-40°C	0.75kW / 4.0A	1.1kW / 5.4A	1.5kW / 7.0A	
Max. permissible ambient temp. with nominal output current						
S1			1~ 40°C / 3~ 50°C	40°C	40°C	
S3 70% ED 10 min			50°C	50°C	50°C	
S6 70% ED 10 min (100% / 20% Mn)			50°C	50°C	50°C	
Wall mounting (unventilated)						
Max. continuous power / max. continuous current:						
(deviating value for 1~ operation in brackets)		S1-50°C	0.75kW / 4.0A (3.4A)	0.75kW / 4.0A (3.6A)	1.1kW / 5.5A	
		S1-40°C	0.75kW / 4.0A	0.75kW / 4.5A (4.4A)	1.5kW / 6.5A	
Max. permissible ambient temp. with nominal output current						
S1			1~ 40°C / 3~ 45°C	1~ 30°C / 3~ 40°C	30°C	
S3 70% ED 10 min			50°C	1~ 40°C / 3~ 50°C	40°C	
S6 70% ED 10 min (100% / 20% Mn)			50°C	1~ 40°C / 3~ 50°C	40°C	
			General fuses (AC) (recommended)			
slow-blowing			16 A	16 A	16 A	
			UL fuses (AC) – permitted			
		Class	Isc ²⁾ [A]			
			10 000	65 000	100 000	
Fuse ³⁾	RK5	(x)	x	30 A	30 A	30 A
	CC, J, R, T, G, L	(x)	x	30 A	30 A	30 A
CB ⁴⁾	(≥ 230 V)		x	30 A	30 A	30 A

1) FLA motor installation: relates to a motor with fan

2) Maximum permissible mains overload current

3) The use of a SK TU4-MSW(-...) module limits the permissible short circuit current in the mains to 10 kA

4) "inverse time trip type" in accordance with UL 489

a) FLA: 4.4 A (S1-40°C)

7.3.3 Electrical data 3~ 400 V

Device type	SK 1x0E...	-250-340-	-370-340-	-550-340-	-750-340-	-111-340-			
	Size	1	1	1	1	1			
Nominal motor power (4-pole standard motor)	400 V	0.25 kW	0.37 kW	0.55 kW	0.75 kW	1.1 kW			
	480 V	1/3 hp	1/2 hp	3/4 hp	1 hp	1 1/2 hp			
Mains voltage	400 V	3 AC 380 ... 480 V, - 20% / + 10%, 47 ... 63 Hz							
Input current	rms	2.0 A	2.3 A	2.6 A	3.2 A	4.1 A			
	FLA	2.0 A	2.3 A	2.6 A	3.2 A	4.1 A			
Output voltage	400 V	3 AC 0 ... Mains voltage							
Output current ¹⁾	rms	1.2 A	1.5 A	1.7 A	2.3 A	3.1 A			
	FLA motor mounting	1.1 A	1.3 A	1.5 A	2.1 A	2.8 A (S1-40°C)			
	FLA wall mounting	1.1 A	1.3 A	1.5 A	2.1 A ^{a)} (S1-40°C)	2.8 A (S1-40°C)			
Motor-mounted (ventilated)									
Max. continuous power / max. continuous current:									
S1-50°C		0.25kW / 1.2A	0.37kW / 1.5A	0.55kW / 1.7A	0.75kW / 2.3A	0.75kW / 2.3A			
S1-40°C		0.25kW / 1.2A	0.37kW / 1.5A	0.55kW / 1.7A	0.75kW / 2.3A	1.10kW / 3.1A			
Max. permissible ambient temp. with nominal output current									
S1		50°C	50°C	50°C	50°C	40°C			
S3 70% ED 10 min		50°C	50°C	50°C	50°C	50°C			
S6 70% ED 10 min (100% / 20% Mn)		50°C	50°C	50°C	50°C	50°C			
Wall mounting (unventilated)									
Max. continuous power / max. continuous current:									
S1-50°C		0.25kW / 1.2A	0.37kW / 1.5A	0.55kW / 1.7A	0.75kW / 2.0A	0.75kW / 2.0A			
S1-40°C		0.25kW / 1.2A	0.37kW / 1.5A	0.55kW / 1.7A	0.75kW / 2.3A	1.10kW / 2.6A			
Max. permissible ambient temp. with nominal output current									
S1		50°C	50°C	50°C	40°C	30°C			
S3 70% ED 10 min		50°C	50°C	50°C	50°C	40°C			
S6 70% ED 10 min (100% / 20% Mn)		50°C	50°C	50°C	50°C	40°C			
General fuses (AC) (recommended)									
slow-blowing		10 A	10 A	10 A	10 A	10 A			
Class		UL fuses (AC) – permitted							
		Isc ²⁾ [A]							
		10 000	65 000	100 000					
Fuse ³⁾	RK5	(x)		x	5 A	5 A	5 A	5 A	10 A
	CC, J, R, T, G, L	(x)		x	5 A	5 A	5 A	5 A	10 A
CB ⁴⁾	(≥ 400 V)			x	5 A	5 A	5 A	5 A	10 A

1) FLA motor installation: relates to a motor with fan

2) Maximum permissible mains overload current

3) The use of a SK TU4-MSW(-...) module limits the permissible short circuit current in the mains to 10 kA

4) "inverse time trip type" in accordance with UL 489

a) FLA: 2.0 A (S1-50°C)

Device type	SK 1x0E...	-151-340-	-221-340-			
	Size	2	2			
Nominal motor power (4-pole standard motor)	400 V	1.5 kW	2.2 kW			
	480 V	2 hp	3 hp			
Mains voltage	400 V	3 AC 380 ... 480 V, - 20% / + 10%, 47 ... 63 Hz				
Input current	rms	6.0 A	7.0 A			
	FLA	5.7 A	7.0 A			
Output voltage	400 V	3 AC 0 ... Mains voltage				
Output current ¹⁾	rms	4.0 A	5.5 A			
	FLA motor mounting	3.6 A	4.9 A			
	FLA wall mounting	3.6 A (S1-40°C)	4.9 A ^{a)} (S1-30°C)			
Min. braking resistor	Accessories	180 Ω	130 Ω			
Motor-mounted (ventilated)						
Max. continuous power / max. continuous current:						
	S1-50°C	1.5kW / 4.0A	1.5kW / 4.0A			
	S1-40°C	1.5kW / 4.0A	2.2kW / 5.5A			
Max. permissible ambient temp. with nominal output current						
	S1	50°C	40°C			
	S3 70% ED 10 min	50°C	50°C			
	S6 70% ED 10 min (100% / 20% Mn)	50°C	50°C			
Wall mounting (unventilated)						
Max. continuous power / max. continuous current:						
	S1-50°C	1.1kW / 2.5A	1.1kW / 2.5A			
	S1-40°C	1.5kW / 3.5A	1.5kW / 3.5A			
Max. permissible ambient temp. with nominal output current						
	S1	30°C	20°C			
	S3 70% ED 10 min	40°C	30°C			
	S6 70% ED 10 min (100% / 20% Mn)	40°C	30°C			
				General fuses (AC) (recommended)		
slow-blowing		10 A	10 A			
		UL fuses (AC) – permitted				
		Isc ²⁾ [A]				
Class		10 000	65 000	100 000		
Fuse ³⁾	RK5	(x)		x	10 A	10 A
	CC, J, R, T, G, L	(x)		x	10 A	10 A
CB ⁴⁾	(≥ 400 V)		x		10 A	10 A

1) FLA motor installation: relates to a motor with fan

2) Maximum permissible mains overload current

3) The use of a SK TU4-MSW(-...) module limits the permissible short circuit current in the mains to 10 kA

4) "inverse time trip type" in accordance with UL 489

a) FLA: 4.0 A (S1-40°C)

8 Additional information

8.1 Setpoint processing

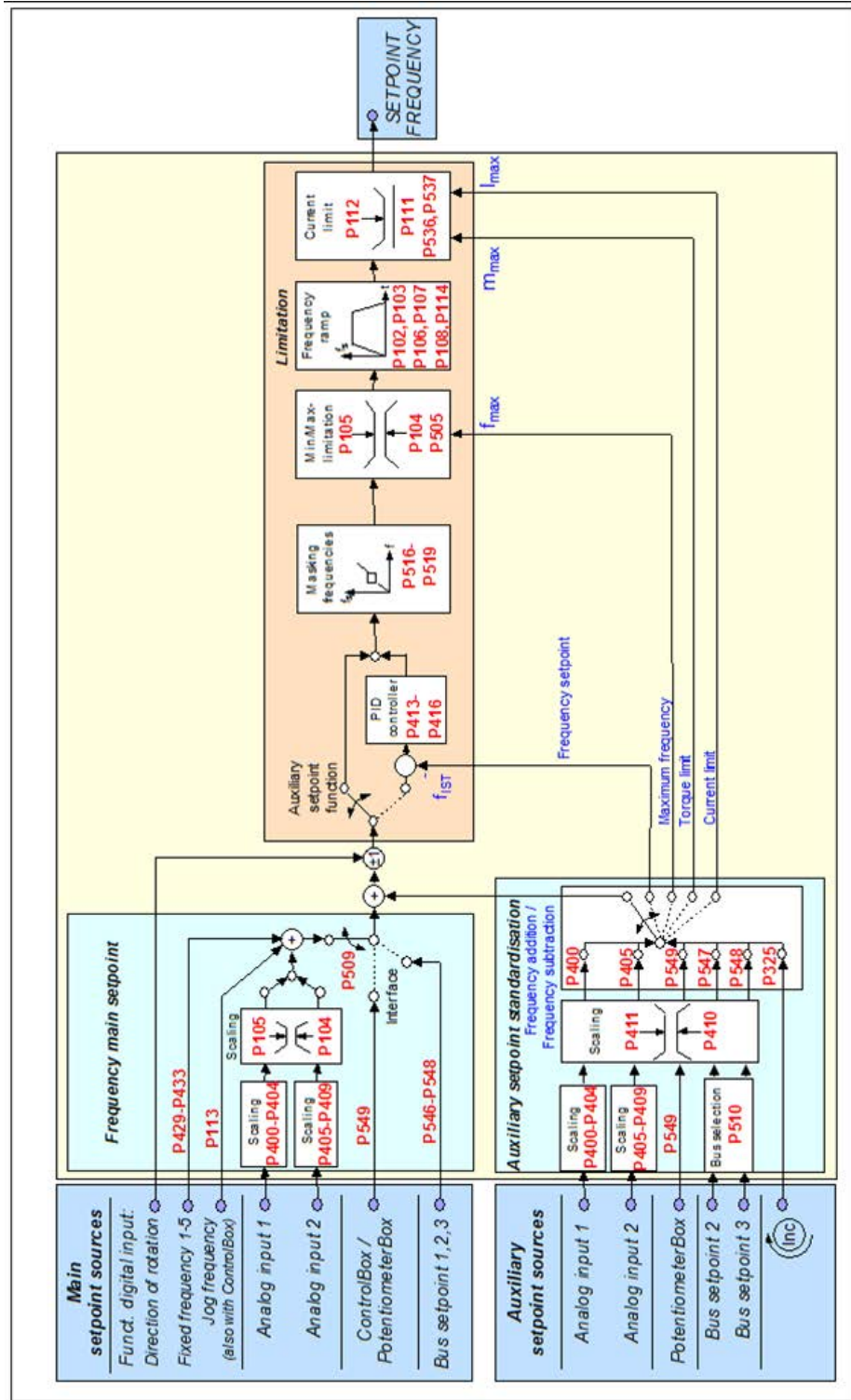

Figure 13 Setpoint processing

8.2 Process controller

The process controller is a PI controller, which allows for the limitation of the controller output. In addition, the output is scaled to a master setpoint on a percentage basis. This allows for the control of an existing downstream drive with the master setpoint, and for the readjustment with the PI controller.

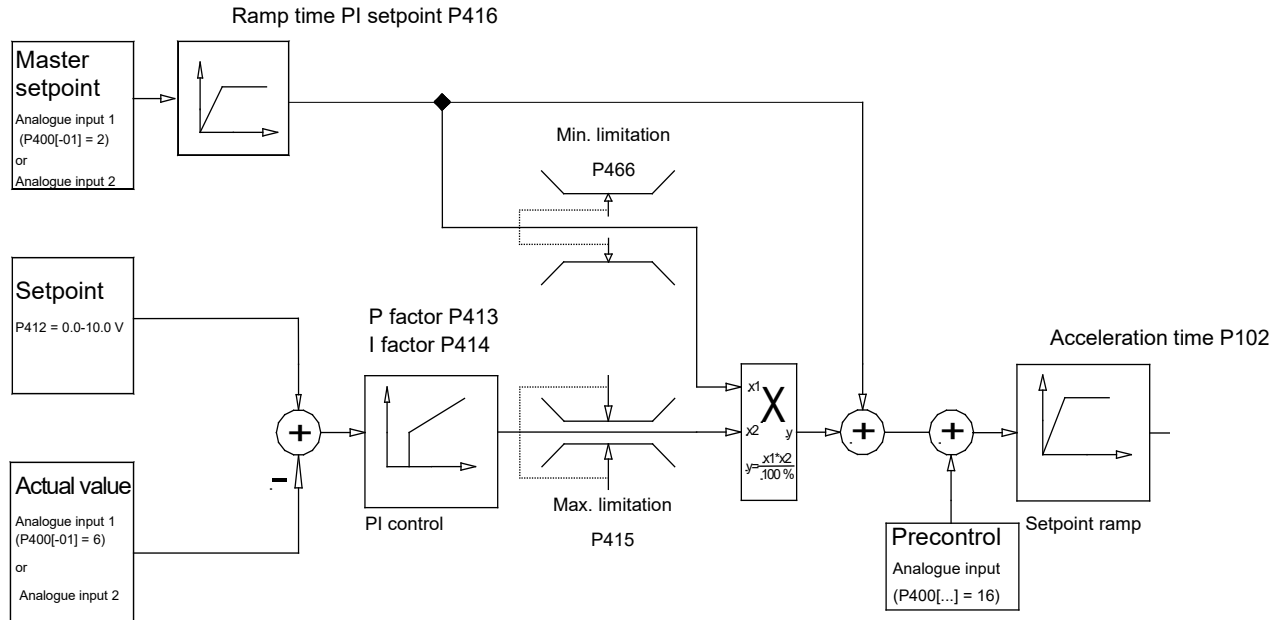
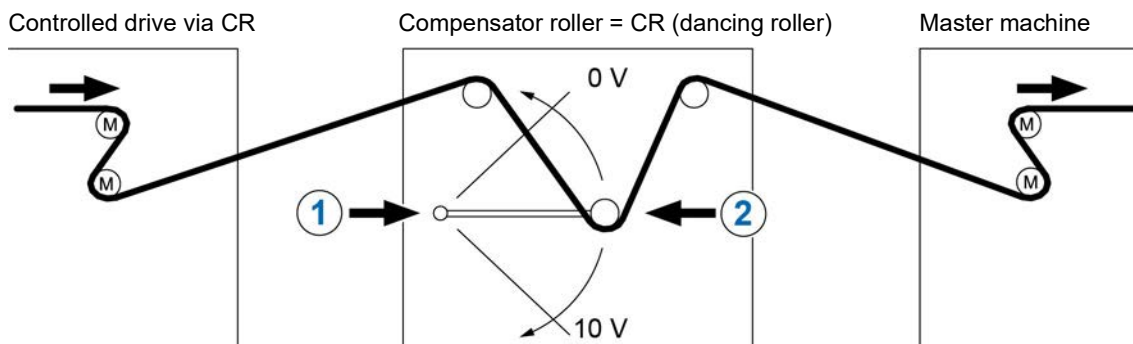
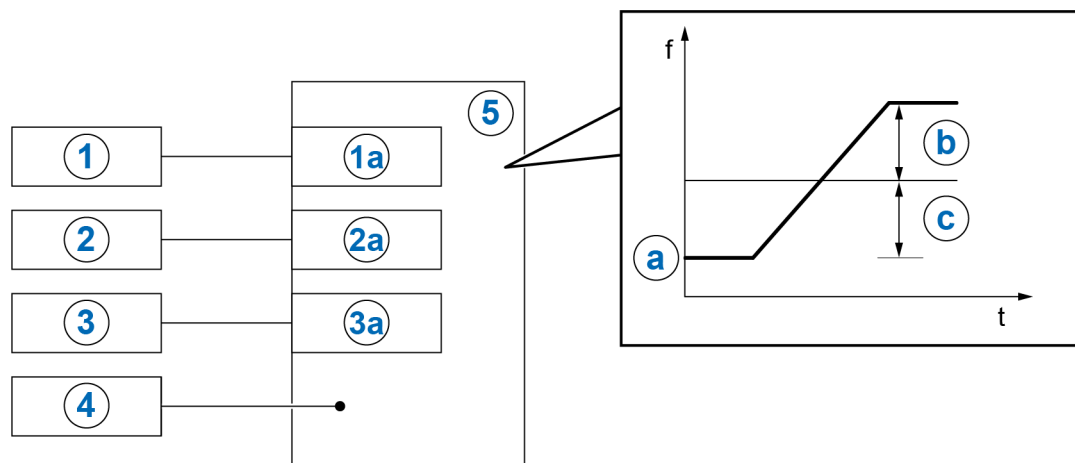

Figure 14: Flow chart: Process controller

8.2.1 Sample application: Process controller



- 1 Current position of CR via potentiometer 0 ... 10 V
- 2 Centre = 5 V setpoint position



1	Setpoint of master machine	1 a	Analog input 1
2	Enable right	2 a	Digital input 1
3	Current position of compensator roller	3 a	Analog input 2
4	Correction factor Setpoint position of compensator roller via parameter P412	5	Frequency inverter
a	Setpoint of master machine		
b	Control limit P415 in % of setpoint		
c	Control limit P415		

Figure 15: Sample application: Dancing roller

8.2.2 Process controller parameter settings

(Example: setpoint frequency: 50 Hz, control limits: +/- 25%)

$$P105 \text{ (maximum frequency) [Hz]} : \geq \text{Setpoint freq. [Hz]} + \left(\frac{\text{Setpoint freq. [Hz]} \times P415 [\%]}{100\%} \right)$$

$$\text{Example: } \geq 50\text{Hz} + \frac{50\text{Hz} \times 25\%}{100\%} = \mathbf{62.5\text{Hz}}$$

P400 [-01] (Funct. Analogue input1) : **"2"** (frequency addition)

P411 (setpoint frequency) [Hz] : Set frequency with 10 V at analogue input 1

Example: **50 Hz**

P412 (Process controller setpoint) : CR middle position / Default setting **5V** (adjust if necessary)

P413 (P controller) [%] : Factory setting **10%** (adjust if necessary)

P414 (I-controller) [%/ms] : recommended **100%/s**

P415 (limitation +/-) [%] : Controller limitation (see above)

Note: Parameter P415 is used as a control limit after the PI controller.

Example: **25%** of setpoint

P416 (Ramp time PI setpoint) [s]	: Factory setting 2s (if necessary, adjust to match controller behaviour)
P420 [-01] (Funct. digital input 1)	: "1" Enable right
P400 [-02] (Funct. Analogue input 2)	: "6" PI process controller actual value

8.3 Electromagnetic compatibility (EMC)

If the device is installed according to the recommendations in this manual, it meets all EMC directive requirements, as per the EMC product standard EN 61800-3.

8.3.1 General Provisions

As of July 2007, all electrical equipment which has an intrinsic, independent function and which is sold as an individual unit for end users, must comply with Directive 2004/108/EEC (formerly Directive EEC/89/336). There are three different ways for manufacturers to indicate compliance with this directive:

1. *EU Declaration of Conformity*

This is a declaration from the manufacturer, stating that the requirements in the applicable European standards for the electrical environment of the equipment have been met. Only those standards which are published in the Official Journal of the European Community may be cited in the manufacturer's declaration.

2. *Technical documentation*

Technical documentation can be produced which describes the EMC characteristics of the device. This documentation must be authorised by one of the "Responsible bodies" named by the responsible European government. This makes it possible to use standards which are still in preparation.

3. *EU Type test certificate*

This method only applies to radio transmitter equipment.

The devices only have an intrinsic function when they are connected to other equipment (e.g. to a motor). The base units cannot therefore carry the CE mark that would confirm compliance with the EMC directive. Precise details are therefore given below about the EMC behaviour of this product, based on the proviso that it is installed according to the guidelines and instructions described in this documentation.

The manufacturer can certify that his equipment meets the requirements of the EMC directive in the relevant environment with regard to their EMC behaviour in power drives. The relevant limit values correspond to the basic standards EN 61000-6-2 and EN 61000-6-4 for interference immunity and interference emissions.

8.3.2 EMC evaluation

Two standards must be observed when evaluating electromagnetic compatibility.

1. EN 55011 (environmental standard)

In this standard, the limit values are defined in dependence on the basic environment in which the product is operated. A distinction is made between two environments, where the **first environment** describes the non-industrial **living and business area** without its own high-voltage or medium-voltage distribution transformers. The **second environment** defines **industrial areas**, which are not connected to the public low-voltage network, but have their own high-voltage or medium-voltage distribution transformers. The limit values are subdivided into **classes A1, A2 and B**.

2. EN 61800-3 (product standard)

In this standard, the limit values are defined in dependence on the usage area of the product. The limit values are subdivided into **categories C1, C2, C3 and C4**, where class C4 basically only applies to drive systems with higher voltage (≥ 1000 V AC) or higher current (≥ 400 A). However, class C4 can also apply to the individual device if it is incorporated in complex systems.

The same limit values apply to both standards. However, the standards differ with regard to an application that is extended in the product standard. The operator decides which of the two standards applies, whereby the environmental standard typically applies in the event of a fault remedy.

The main connection between the two standards is explained as follows:

Category according to EN 61800-3	C1	C2	C3
Limit value class according to EN 55011	B	A1	A2
Operation permissible in First environment (living environment)	X	X ¹⁾	-
Second environment (industrial environment)	X	X ¹⁾	X ¹⁾
Note required in accordance with EN 61800-3	-	²⁾	³⁾
Distribution channel	Generally available	Limited availability	
EMC expertise	No requirements	Installation and commissioning by EMC expert	

1) Device used neither as a plug-in device nor in moving equipment

2) "The drive system can cause high-frequency interference in a living environment that may make interference suppression measures necessary."

3) "The drive system is not intended for use in a public low-voltage network that feeds residential areas."

Table 13: EMC comparison between EN 61800-3 and EN 55011

8.3.3 EMC of device

NOTICE

EMC interference to the environment

This device produces high-frequency interference, which may make additional suppression measures necessary in domestic environments 8.3.3 "EMC of device".

- Use of shielded motor cables is essential in order to comply with the specified radio interference suppression level.

The frequency inverter is designed for connection in industrial networks. In principle, it generates **harmonics** that exceed the harmonic limit values of EN IEC 61000-3-2 or EN IEC 61000-3-12. Additional external filtering measures are required to connect the individual frequency inverter to the public low-voltage network in accordance with IEC 61000-3-2 and IEC 61000-3-1.

If one or more frequency inverters are installed in a facility within the scope of IEC 61000-3-2 and IEC 61000-3-12, the requirements of these standards apply to the complete facility and not to the individual frequency inverter. The application of harmonic limit values to every frequency inverter is not recommended from neither a technical nor an economical point of view. Rather, a global approximation should be applied for filtering the entire system, which is based on the addition of all harmonic currents generated in the system. The system operator is responsible for this procedure.

Voltage fluctuations in a supply network essentially depend on the following factors:

- System design
- System impedance
- Load cycles

Therefore, the manufacturer of the machine or the system operator is responsible for evaluating the voltage fluctuations and ensuring compliance with the limit values according to IEC 61000-3-3 or IEC 61000-3-11.

The device is exclusively intended for commercial use. It is therefore not subject to the requirements of the standard EN 61000-3-2 for radiation of harmonics.

The limit value classes are only achieved if

- the wiring is EMC-compliant
- the length of shielded motor cable does not exceed the permissible limits
- the standard pulse frequency (P504) is being used

The shielding of the motor cable must be attached at both sides in the motor terminal box and the inverter housing in the event of wall mounting.

Device type Max. motor cable, shielded	Jumper position (chapter 2.4.2.1)	Conducted emissions 150 kHz - 30 MHz	
		Class C2	Class C1
Device motor-mounted	Jumper set (CY=ON)	+	+
Device wall-mounted	Jumper set (CY=ON)	5 m	-

EMC overview of standards that are used in accordance with EN 61800-3 as checking and measuring procedures:		
<i>Interference emission</i>		
Cable-related emission (interference voltage)	EN 55011	C2
		C1 (mounted on motor)
Radiated emission (interference field strength)	EN 55011	C2
		C1 (mounted on motor)
<i>Interference immunity EN 61000-6-1, EN 61000-6-2</i>		
ESD, discharge of static electricity	EN 61000-4-2	6 kV (CD), 8 kV (AD)
EMF, high frequency electro-magnetic fields	EN 61000-4-3	10 V/m; 80 – 1000 MHz
Burst on control cables	EN 61000-4-4	1 kV
Burst on mains and motor cables	EN 61000-4-4	2 kV
Surge (phase-phase / phase-ground)	EN 61000-4-5	1 kV / 2 kV
Cable-led interference due to high frequency fields	EN 61000-4-6	10 V, 0.15 – 80 MHz
Voltage fluctuations and drops	EN 61000-2-1	+10 %, -15 %; 90 %
Voltage asymmetries and frequency changes	EN 61000-2-4	3 %; 2 %

Table 14: Overview according to product standard EN 61800-3

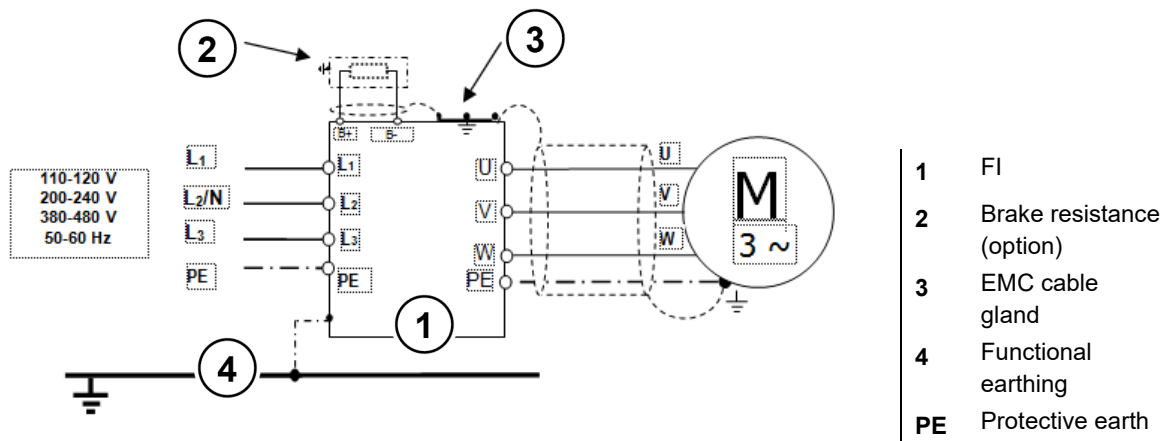



Figure 16: Wiring recommendation

8.3.4 Declarations of Conformity



GETRIEBEBAU NORD

Member of the NORD DRIVESYSTEMS Group

Getriebebau NORD GmbH & Co. KG
 Getriebebau-Nord-Str. 1 · 22941 Bargteheide, Germany · Fon +49(0)4532 289 - 0 · Fax +49(0)4532 289 - 2253 · info@nord.com C310400_1021

EU Declaration of Conformity

In the meaning of the EU directives 2014/35/EU Annex IV, 2014/30/EU Annex II, 2009/125/EG Annex IV and 2011/65/EU Annex VI

Getriebebau NORD GmbH & Co. KG as manufacturer in sole responsibility hereby declares,

Page 1 of 1

that the variable speed drives from the product series NORDAC BASE

- SK 180E-xxx-123-B-.. , SK 180E-xxx-323-B-.. , SK 180E-xxx-340-B-..
- SK 190E-xxx-123-B-.. , SK 190E-xxx-323-B-.. , SK 190E-xxx-340-B-..
 (xxx= 250, 370, 550, 750, 111, 151, 221)

and the further options/accessories:

**SK CU4-... , SK TU4-... , SK TI4-... , SK TIE4-... , SK BRI4-... , SK BRE4-... ,
 SK PAR-3. , SK CSX-3. , SK SSX-3A, SK POT1- , SK TIE5-BT-STICK**

comply with the following regulations:

Low Voltage Directive	2014/35/EU	OJ. L 96 of 29.3.2014, p. 357–374
EMC Directive	2014/30/EU	OJ. L 96 of 29.3.2014, p. 79–106
Ecodesign Directive	2009/125/EG	OJ. L 285 of 31.10.2009, p. 10–35
Regulation (EU) Ecodesign	2019/1781	OJ. L 272 of 25.10.2019, p. 74–94
RoHS Directive	2011/65/EU	OJ. L 174 of 1.7.2011, p. 88–11
Delegated Directive (EU)	2015/863	OJ. L 137 of 4.6.2015, p. 10–12

Applied standards:

EN 61800-5-1:2007+A1:2017	EN 61800-3:2018	EN 61800-9-1:2017
EN 60529:1991+A1:2000+A2:2013+AC:2016	EN 63000:2018	EN 61800-9-2:2017

It is necessary to notice the data in the operating manual to meet the regulations of the EMC-Directive.
 Specially take care about correct EMC installation and cabling, differences in the field of applications and if
 necessary original accessories.

First marking was carried out in 2014.

Bargteheide, 12.03.2021



U. Küchenmeister
Managing Director



pp F. Wiedemann
Head of Inverter Division

NORD GEAR LIMITED

Member of the NORD DRIVESYSTEMS GROUP



NORD Gear Limited
11 Barton Lane, Abingdon, Oxfordshire, United Kingdom OX14 3NB | Tel. No.: +44 1235 534404 | Email: GB-Sales@nord.com

DoC number C350400_0821_EN_UKCA

UK
CA

Declaration of Conformity

NORD Gear Limited hereby declares under sole responsibility that the product series as originally delivered:

SK 180E-xxx-123-B-., SK 180E-xxx-323-B-., SK 180E-xxx-340-B-..
SK 190E-xxx-123-B-., SK 190E-xxx-323-B-., SK 190E-xxx-340-B-..
 (xxx = 250, 370, 550, 750, 111, 151, 221)

and further options/accessories:
SK CU4-., SK TU4-., SK TI4-., SK TIE4-., SK BRI4-., SK BRE4-., SK PAR-3., SK CSX-3.,
SK SSX-3A, SK POT1-., SK TIE5-BT-STICK

complies with the following statutory requirements and carries the UKCA marking accordingly:	and conforms with the following designated standards:
Electrical Equipment (Safety) Regulations S.I. 2016/1101 (as amended)	EN 61800-5-1:2007+A1:2017 EN 61800-9-1:2017 EN 61800-9-2:2017 EN 60529:1991+A1:2000+A2:2013+AC:2016
Electromagnetic Compatibility Regulations S.I. 2016/1091 (as amended)	EN 61800-3:2004+A1:2012+AC:2014
Restriction of the Use of Certain Hazardous Substances in Electrical and Electronic Equipment Regulations S.I. 2012/3032 (as amended)	BS EN IEC 63000:2018

According to the EMC directive, the listed devices are not independently operable products, they are intended for installation in machines. Compliance to the directive requires the correct installation of the product, it is necessary to take notice of the data and safety instructions in the installation and operating manual. Specifically take care regarding the correct EMC installation and cabling requirements.

Abingdon, 07.04.2021



Andrew Stephenson
Managing Director

8.4 Reduced output power

The frequency inverters are designed for special overload situations. For example, 1.5x overcurrent can be used for 60 s. For approx. 3.5 s, 2x overcurrent is possible. A reduction of the overload capacity or its duration must be considered for the following circumstances:

- Output frequencies < 4.5 Hz and DC voltage (stationary pointer)
- Pulse frequencies greater than the nominal pulse frequency (P504)
- Increased mains voltages > 400 V
- Increased heat sink temperature

The following characteristic curves can be used to obtain the corresponding current/power limit.

8.4.1 Increased heat dissipation due to pulse frequency

This illustration shows how the output current must be reduced, depending on the pulse frequency for 230V and 400V devices, in order to avoid excessive heat dissipation in the frequency inverter.

For 400V devices, the reduction begins at a pulse frequency above 6kHz. For 230V devices, the reduction begins at a pulse frequency above 8kHz.

The diagram shows the possible current load capacity for continuous operation.

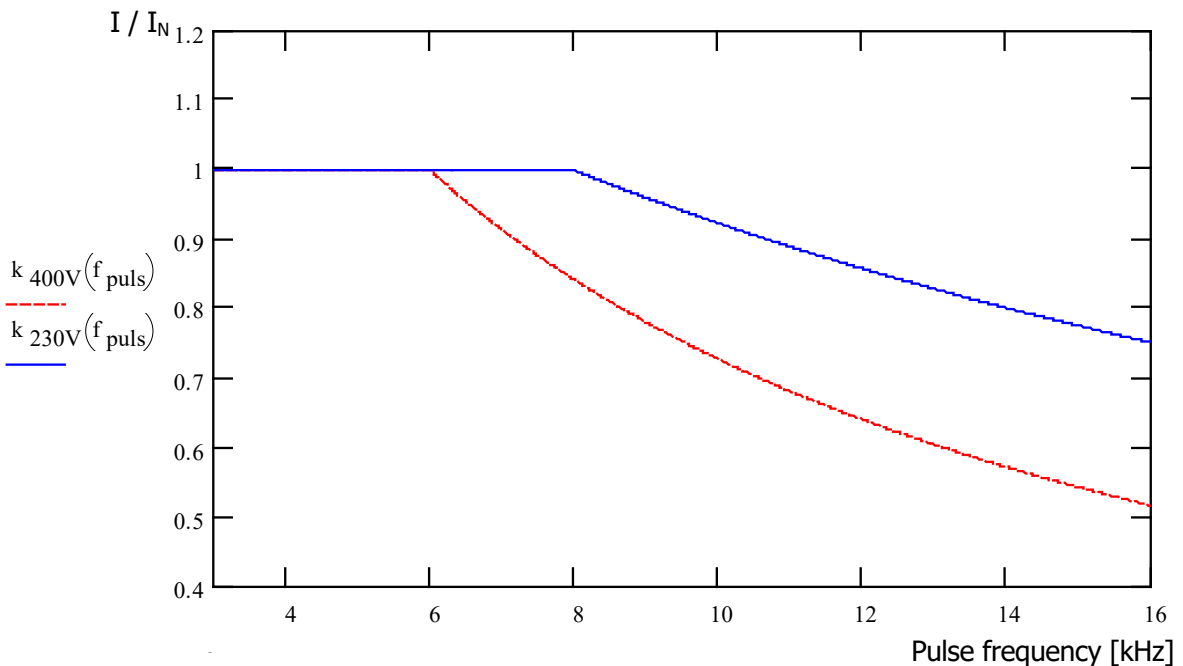

Figure 17: Heat losses due to pulse frequency

8.4.2 Reduced overcurrent due to time

The possible overload capacity changes depending on the duration of an overload. Several values are cited in this table. If one of these limiting values is reached, the frequency inverter must have sufficient time (with low utilisation or without load) in order to regenerate itself.

If operated repeatedly in the overload region at short intervals, the limiting values stated in the tables are reduced.

230V devices: Reduced overload capacity (approx.) due to pulse frequency (P504) and time						
Pulse frequency [kHz]	Time [s]					
	> 600	60	30	20	10	3.5
3...8	110%	150%	170%	180%	180%	200%
10	103%	140%	155%	165%	165%	180%
12	96%	130%	145%	155%	155%	160%
14	90%	120%	135%	145%	145%	150%
16	82%	110%	125%	135%	135%	140%

400V devices: Reduced overload capacity (approx.) due to pulse frequency (P504) and time						
Pulse frequency [kHz]	Time [s]					
	> 600	60	30	20	10	3.5
3...6	110%	150%	170%	180%	180%	200%
8	100%	135%	150%	160%	160%	165%
10	90%	120%	135%	145%	145%	150%
12	78%	105%	120%	125%	125%	130%
14	67%	92%	104%	110%	110%	115%
16	57%	77%	87%	92%	92%	100%

Table 15: Overcurrent relative to time

8.4.3 Reduced overcurrent due to output frequency

To protect the power unit at low output frequencies (<4.5 Hz) a monitoring system is provided, with which the temperature of the IGBTs (*insulated-gate bipolar transistor*) due to high current is determined. In order to prevent current being taken off above the limit shown in the diagram, a pulse switch-off (P537) with a variable limit is introduced. At a standstill, with 6 kHz pulse frequency, current above 1.1x the nominal current cannot be taken off.

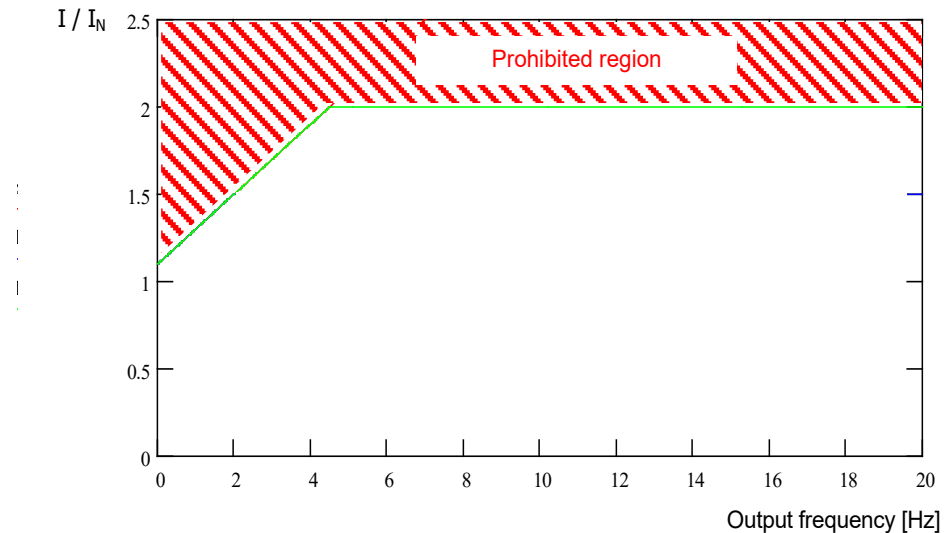

The upper limiting values for the various pulse frequencies can be obtained from the following tables. In all cases, the value (10 ... 201) which can be set in parameter P537, is limited to the value stated in the tables according to the pulse frequency. Values below the limit can be set as required.

230 V devices: Reduced overload capacity (approx.) due to pulse frequency (P504) and output frequency							
Pulse frequency [kHz]	Output frequency [Hz]						
	4.5	3.0	2.0	1.5	1.0	0.5	0
3 ... 8	200 %	170 %	150 %	140 %	130 %	120 %	110 %
10	180 %	153 %	135 %	126 %	117 %	108 %	100 %
12	160 %	136 %	120 %	112 %	104 %	96 %	95 %
14	150 %	127 %	112 %	105 %	97 %	90 %	90 %
16	140 %	119 %	105 %	98 %	91 %	84 %	85 %

400V devices: Reduced overload capacity (approx.) due to pulse frequency (P504) and output frequency							
Pulse frequency [kHz]	Output frequency [Hz]						
	4.5	3.0	2.0	1.5	1.0	0.5	0
3 ... 6	200 %	170 %	150 %	140 %	130 %	120 %	110 %
8	165 %	140 %	123 %	115 %	107 %	99 %	90 %
10	150 %	127 %	112 %	105 %	97 %	90 %	82 %
12	130 %	110 %	97 %	91 %	84 %	78 %	71 %
14	115 %	97 %	86 %	80 %	74 %	69 %	63 %
16	100 %	85 %	75 %	70 %	65 %	60 %	55 %

Table 16: Overcurrent relative to pulse and output frequency

8.4.4 Reduced output current due to low voltage

The frequency inverters are thermally designed with regard to the rated output currents. For lower low voltages larger currents cannot be used in order to keep the output power constant. For mains voltages above 400 V the permissible output current is reduced inversely proportional to the mains voltage in order to compensate for switching losses.

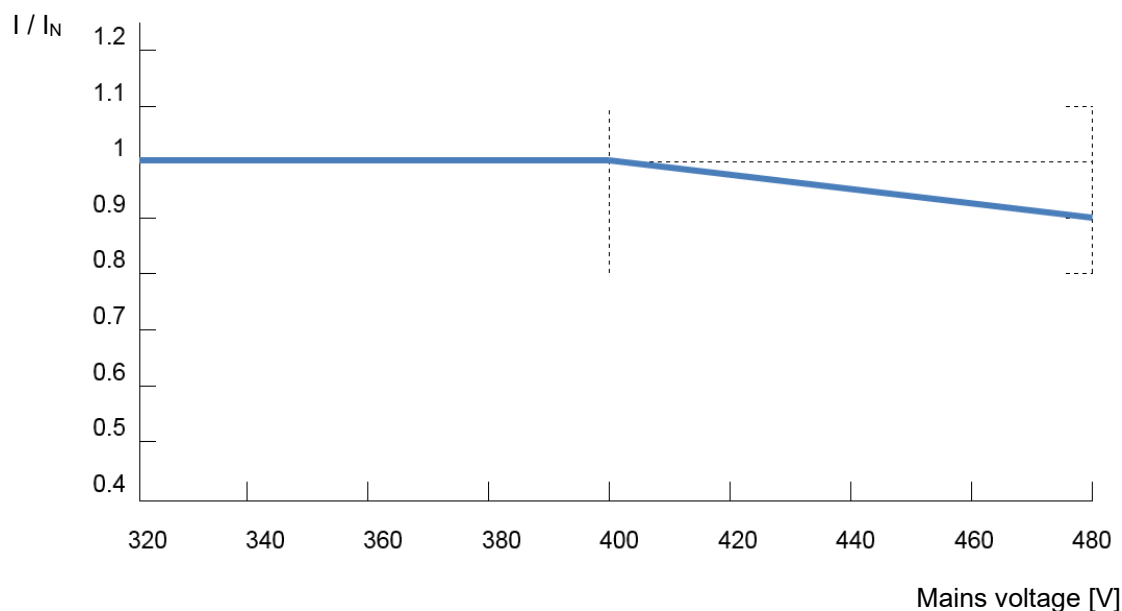

Figure 18: Reduced output current due to low voltage

8.4.5 Reduced output current due to heat sink temperature

The heat sink temperature is included in the output current reduction so that a higher load capacity can be permitted at low heat sink temperatures, especially for higher pulse frequencies. The reduction is increased accordingly for high heat sink temperatures. The ambient temperature and ventilation conditions for the device can thus be utilised more optimally.

8.5 Operation on the RCD

When the mains filter is activated (standard configuration), the device is suitable for operation on a RCD (30 mA).

Only all-current sensitive RCDs (type B or B+) must be used.

Please also note the information on the leakage currents in the technical data (see chapter 7.1 "General frequency inverter data") and Chapter 2.4.2.1 "Mains supply (L1, L2(/N), L3, PE)".

( See also document [TI 800_000000003](#))

8.6 System bus

The device and many of the associated components communicate with each other via the system bus. This bus system is a CAN bus with CANopen protocol. Up to four frequency inverters and their components (field bus module, absolute encoder, I/O modules etc.) can be connected to the system bus. Integration of the components into the system bus does not require any specific knowledge of the bus on the part of the user.

Only the proper physical configuration of the bus system and if necessary the correct addressing of the participants need to be taken into account by the user.

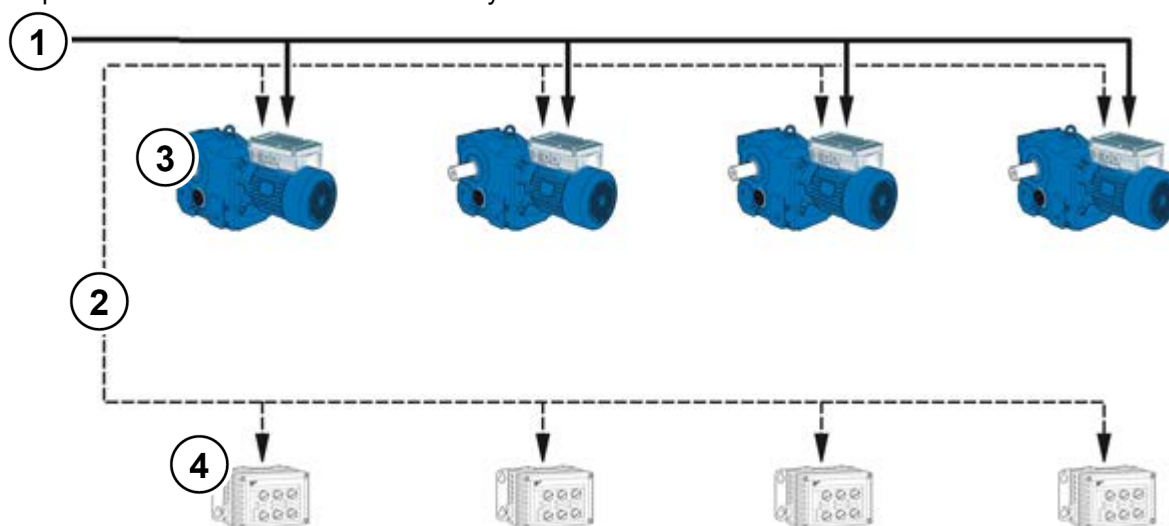

No.	Type
1	Mains connection
2	System bus cable (CAN_H, CAN_L, GND)
3	Frequency inverters
4	Options <ul style="list-style-type: none"> • Bus modules • IO Extensions • CANopen rotary encoder

Terminal	Meaning
77	System bus+ (CAN_H)
78	System bus- (CAN_L)
40	GND (Reference potential)
Terminal numbers may differ (depending on the device)	

Information

Communication interference

To minimise the risk of communication interference, the **GND –potentials** (Terminal 40) of all GNDs which are linked via the system bus GND **must be connected together**. The shield of the bus cable must also be connected to PE at both ends.

Information

Communication on the system bus

Communication on the system bus does not take place until an expansion module is connected to it or if the master in a master/slave system is parameterised to **P503=3** and the slave to **P503=2**. This is particularly important if several frequency inverters connected to the system bus in parallel are to be read out using the NORDCON parameterisation software.

Physical structure

Standard	CAN
Physical design	2x2, twisted pair, shielded, stranded wires, wire cross-section $\geq 0.25 \text{ mm}^2$ (AWG23), surge impedance approx. 120 Ω
Bus length	max. 20 m total expansion (network), max. 20 m between 2 subscribers,
Structure	preferably linear
Spur cables	possible, (max. 6 m)
Termination resistors	120 Ω , 250 mW at both ends of a system bus (with FI or SK xU4-... via DIP switches)
Baud rate	250 kBaud - preset

The CAN_H and CAN_L signals must be connected using a twisted pair of wires. The GND potentials are connected using the second pair of wires.



Addressing

If several frequency inverters are connected to a system bus, these devices must be assigned with unique addresses. This should preferably take place via the DIP switch S2 at the device (see chapter 4.3.2.2 "DIP switches (S1, S2)").

For field bus modules, no assignment of addresses is necessary. The module identifies all the frequency inverters automatically. Access to the individual inverters takes place via the field bus master (PLC). Details of how this is carried out are explained in the relevant bus instructions or data sheets for the individual modules.

I/O extensions must be assigned to the relevant frequency inverter. This is carried out by means of a DIP switch on the I/O module. A special case for the I/O extensions is the "Broadcast" mode. In this mode, the data of the I/O extension (analogue values, inputs etc.) are sent to all inverters simultaneously. Via the parameterisation in each individual frequency inverter, a decision is made as to which of the received values are to be used. More information about the settings can be found in the [Data sheets](#) for the relevant modules.



Information

Addressing

Care must be taken that each address is only assigned once. In a CAN-based network double assignment of addresses may lead to misinterpretation of the data and therefore undefined activities in the system.

Integration of devices from other manufacturers

In principle, the integration of other devices into this bus system is possible. These must support the CANopen protocol and a 250 kBaud baud rate. The address range (Node ID) 1 to 4 is reserved for additional CANopen masters. All other participants must be assigned addresses between 50 and 79.

Example of frequency inverter addressing

Frequency inverter	Addressing via DIP switch S2		Resulting Node ID Frequency inverters	
	DIP2	DIP1		
FI 1	OFF	OFF	32	
FI 2	OFF	ON	34	
FI 3	ON	OFF	36	
FI 4	ON	ON	38	

8.7 Energy efficiency optimisation when operating ASMs

⚠ WARNING

Unexpected movement due to overload

In case of overload of the drive, there is a risk that the motor will “break down” (sudden loss of torque). An overload may be caused e.g. by inadequate dimensioning of the drive unit or by the occurrence of sudden peak loads. Sudden peak loads may be of a mechanical origin (e.g. blockage) or may be caused by extremely steep acceleration ramps (P102, P103, P426).

Depending on the type of application, a “breakdown” of the motor may cause unexpected movement (e.g. dropping of loads by lifting equipment).

To prevent risk, the following must be observed:

- For lifting equipment applications or applications with frequent large load changes, parameter P219 must remain in the factory setting (100%).
- Do not inadequately dimension the drive unit, provide adequate overload reserves.
- If necessary, provide protection against falling (e.g. for lifting equipment) or equivalent protective measures.

NORD frequency inverters have a low power consumption and are therefore highly efficient. In addition, with the aid of "Automatic flux optimisation" (Parameter (P219)) the inverter provides a possibility for increasing the overall efficiency of the drive in certain applications (in particular applications with partial load).

According to the torque required, the magnetisation current through the frequency inverter or the motor torque is reduced to the level which is required for the momentary drive power. The resulting considerable reduction in power consumption, as well as the optimisation of the $\cos \varphi$ factor of the motor rating in the partial load range contributes to creating optimum conditions both with regard to energy consumption and mains characteristics.

A parameterisation which is different from the factory setting (Factory setting = 100%) is only permissible for applications which do not require rapid torque changes. (For details, see Parameter (P219))

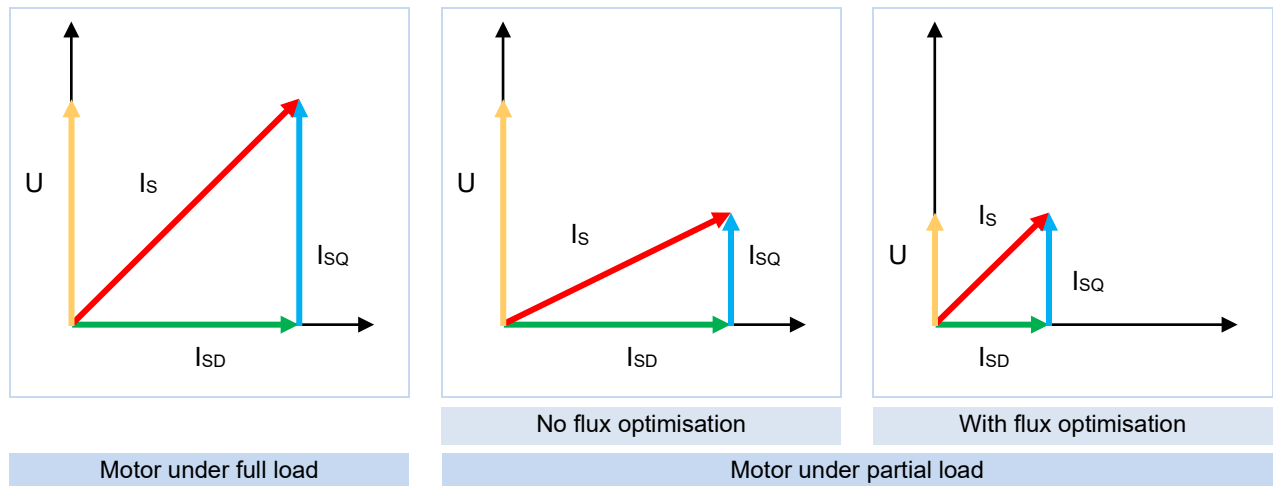

Is = Motor current vector (line current)
 IsD = Magnetisation current vector (magnetisation current)
 IsQ = Load current vector (load current)

Figure 19: Energy efficiency due to automatic flux optimisation

8.8 Motor data – characteristic curves (Asynchronous motors)

The possible characteristic curves with which the motors can be operated are explained in the following. For operation with the 50 Hz or 87 Hz characteristic curve, the name plate data of the motor is relevant (📖 Section 4.1 “Factory settings”). For operation with a 100 Hz characteristic curve, the use of specially calculated motor data is required (📖 Section 8.8.3 “100 Hz characteristic curve (only 400 V devices)”).

8.8.1 50 Hz characteristic curve

(→ Adjustment range 1:10)

For 50 Hz operation, the used motor can be operated up to its rating point at 50 Hz with nominal torque. Operation above 50 Hz is possible, but causes the torque output to reduce in a non-linear manner (see diagram). Above the rating point, the motor enters its field weakening range, as the voltage cannot be increased above the value of the mains voltage if the frequency is increased above 50 Hz.

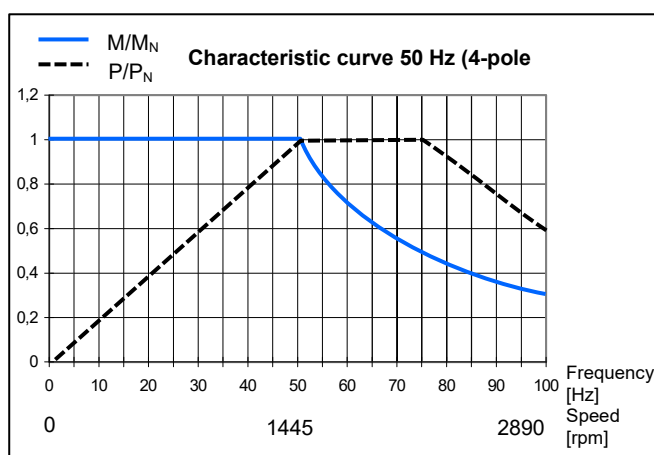

Figure 20: Characteristic curve 50 Hz



Information

Compare motor data with specifications on the name plate.

To be able to optimally adjust the frequency inverter to the motor used, the motor parameters must match with those of the motor.

- Select the motor used in the motor list in parameter **P200**. The motor list indicates the motor data of various NORD motors.
- When using motors of other energy efficiency classes than listed in **P200**, but in particular for use of third-party motors, compare the motor data in parameters **P201** ... **P209** with the specifications on the name plate and correct them if necessary.
- Finally, you must calibrate the stator resistance, see **P220**, or enter it manually in **P208**.

115 V / 230 V – frequency inverter

For 115 V devices, the input voltage is doubled in the device so that the required maximum output voltage of 230 V is achieved for the device.

The following data refers to a 230 V/400 V winding of the motor. It applies to IE1 and IE2 motors. Please note that these specifications may vary slightly, as the motors are subject to certain manufacturing tolerances. It is recommended to have the resistance of the connected motor calibrated by the frequency inverter (**P208 / P220**).

Motor (IE1) SK ...	Frequency inverter SK 1x0E-...	M _N ¹⁾ [Nm]	Motor data for parameterisation							
			F _N [Hz]	n _N [min-1]	I _N [A]	U _N [V]	P _N [kW]	cos φ	Y/Δ	R _{St} [Ω]

Notice: A comma counts as a full stop and signifies a decimal place.

71S/4	250-x23- ²⁾	1,73	50	1365	1,3	230	0,25	0,79	Δ	39,9
71L/4	370-x23- ²⁾	2,56	50	1380	1,89	230	0,37	0,71	Δ	22,85
80S/4	550-x23- ²⁾	3,82	50	1385	2,62	230	0,55	0,75	Δ	15,79
80L/4	750-x23- ²⁾	5,21	50	1395	3,52	230	0,75	0,75	Δ	10,49
90S/4	111-x23-	7,53	50	1410	4,78	230	1,1	0,76	Δ	6,41
90L/4	151-323-	10,3	50	1390	6,11	230	1,5	0,78	Δ	3,99

1) At the rating point

2) The same data applies when using the 115 V variant of the SK 1xxE.

Motor (IE2) SK ...	Frequency inverter SK 1x0E-...	M _N ¹⁾ [Nm]	Motor data for parameterisation							
			F _N [Hz]	n _N [rpm]	I _N [A]	U _N [V]	P _N [kW]	cos φ	Y/Δ	R _{St} [Ω]

Notice: A comma counts as a full stop and signifies a decimal place.

80SH/4	550-x23- ²⁾	3,73	50	1415	2,39	230	0,55	0,7	Δ	9,34
80LH/4	750-x23- ²⁾	5,06	50	1410	3,12	230	0,75	0,75	Δ	6,30
90SH/4	111-x23-	7,32	50	1430	4,26	230	1,1	0,8	Δ	4,96
90LH/4	151-323-	10,1	50	1420	5,85	230	1,5	0,79	Δ	3,27

1) At the rating point

2) The same data applies when using the 115 V variant of the SK 1xxE.

400 V frequency inverter

The following data refer to a power of 2.2 kW on a 230/400 V winding of the motor.

It applies to IE1 and IE2 motors. Please note that these specifications may vary slightly, as the motors are subject to certain manufacturing tolerances. It is recommended to have the resistance of the connected motor calibrated by the frequency inverter (**P208 / P220**).

Motor (IE1) SK ...	Frequency inverter SK 1x0E-...	M _N ¹⁾ [Nm]	Motor data for parameterisation							
			F _N [Hz]	n _N [min ⁻¹]	I _N [A]	U _N [V]	P _N [kW]	cos φ	Y/Δ	R _{St} [Ω]

Notice: A comma counts as a full stop and signifies a decimal place.

80S/4	550-340-	3,82	50	1385	1,51	400	0,55	0,75	Y	15,79
80L/4	750-340-	5,21	50	1395	2,03	400	0,75	0,75	Y	10,49
90S/4	111-340-	7,53	50	1410	2,76	400	1,1	0,76	Y	6,41
90L/4	151-340-	10,3	50	1390	3,53	400	1,5	0,78	Y	3,99
100L/4	221-340-	14,6	50	1415	5,0	400	2,2	0,78	Y	2,78

1) At the rating point

Motor (IE2) SK ...	Frequency inverter SK 1x0E-...	M _N ¹⁾ [Nm]	Motor data for parameterisation							
			F _N [Hz]	n _N [rpm]	I _N [A]	U _N [V]	P _N [kW]	cos φ	Y/Δ	R _{St} [Ω]

Notice: A comma counts as a full stop and signifies a decimal place.

80SH/4	550-340-	3,82	50	1415	1,38	400	0,55	0,7	Y	9,34
80LH/4	750-340-	5,21	50	1410	1,8	400	0,75	0,75	Y	6,30
90SH/4	111-340-	7,53	50	1430	2,46	400	1,1	0,8	Y	4,96
90LH/4	151-340-	10,3	50	1420	3,38	400	1,5	0,79	Y	3,27
100LH/4	221-340-	14,6	50	1445	4,76	400	2,2	0,79	Y	1,73

1) At the rating point

8.8.2 87 Hz characteristic curve (only 400V devices)

(→ Variation 01:17)

The 87 Hz - characteristic represents an extension of the speed adjustment range with a constant motor nominal torque. The following points must be met for realisation:

- Motor delta connection with a motor winding for 230/400 V
- Frequency inverter with an operating voltage 3~400 V
- Output current of frequency inverter must be greater than the delta current of the motor used (ref. value → frequency inverter power $\geq \sqrt{3}$ motor power)

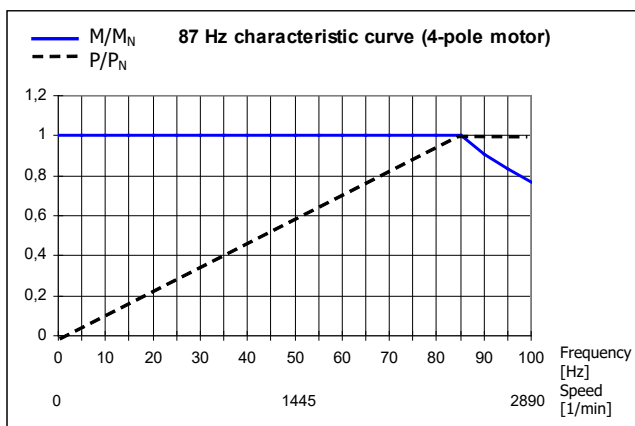

Figure 21: 87 Hz characteristic curve

In this configuration, the motor used has a rated operating point at 230 V/50 Hz and an extended operating point at 400 V/ 87 Hz. This increases the power of the drive by a factor of $\sqrt{3}$. The nominal torque of the motor remains constant up to a frequency of 87 Hz. Operation of a 230 V winding with 400 V is totally uncritical as the insulation is designed for test voltages of > 1000 V.

Information

The following motor data applies to standard motors with a 230 V/400 V winding.

Motor (IE1) SK ...	Frequency inverter SK 1x0E-....	M_N 1) [Nm]	Motor data for parameterisation							
			F_N [Hz]	n_N [min-1]	I_N [A]	U_N [V]	P_N [kW]	$\cos \varphi$	Y/ Δ	R_{St} [Ω]
71S/4	550-340-	1,73	50	1365	1,3	230	0,25	0,79	Δ	39,9
71L/4	750-340-	2,56	50	1380	1,89	230	0,37	0,71	Δ	22,85
80S/4	111-340-	3,82	50	1385	2,62	230	0,55	0,75	Δ	15,79
80L/4	151-340-	5,21	50	1395	3,52	230	0,75	0,75	Δ	10,49
90S/4	221-340-	7,53	50	1410	4,78	230	1,1	0,76	Δ	6,41

Notice: A comma counts as a full stop and signifies a decimal place.

1) At the rating point

Motor (IE2) SK ...	Frequency inverter SK 1x0E-....	M_N 1) [Nm]	Motor data for parameterisation							
			F_N [Hz]	n_N [rpm]	I_N [A]	U_N [V]	P_N [kW]	$\cos \varphi$	Y/ Δ	R_{St} [Ω]
80SH/4	111-340-	3,73	50	1415	2,39	230	0,55	0,7	Δ	9,34
80LH/4	151-340-	5,06	50	1410	3,12	230	0,75	0,75	Δ	6,30
90SH/4	221-340-	7,32	50	1430	4,26	230	1,1	0,8	Δ	4,96

Notice: A comma counts as a full stop and signifies a decimal place.

1) At the rating point

Motor (IE3) SK ...	Frequency inverter SK 1x0E-...	M _N ¹⁾ [Nm]	Motor data for parameterisation							
			F _N [Hz]	n _N [min-1]	I _N [A]	U _N [V]	P _N [kW]	cos φ	Y/Δ	R _{St} [Ω]

Notice: A comma counts as a full stop and signifies a decimal place.

63 SP/4	250-340-	0,84	50	1370	0,68	230	0,12	0,66	Δ	66,7
63 LP/4	370-340-	1,24	50	1385	1,02	230	0,18	0,62	Δ	39,7
71 SP/4	550-340-	1,69	50	1415	1,21	230	0,25	0,71	Δ	24,0
71 LP/4	750-340-	2,51	50	1405	1,58	230	0,37	0,76	Δ	17,7
80 SP/4	111-340-	3,70	50	1420	2,23	230	0,55	0,75	Δ	10,4
80 LP/4	151-340-	5,06	50	1415	3,10	230	0,75	0,72	Δ	6,50
90 SP/4	221-340-	7,35	50	1430	4,12	230	1,1	0,78	Δ	4,16

1) At the rating point

8.8.3 100 Hz characteristic curve (only 400 V devices)

(→ adjustment range 1:20)

An operating point 100 Hz / 400 V can be selected for a large speed adjustment range up to a ratio of 1:20. This requires special motor data (see below) that deviates from the usual 50 Hz data. It must be noted that a constant torque is generated over the entire adjustment range, but that it is less than the nominal torque at 50 Hz operation.

The advantage, in addition to the large speed adjustment range, is the better temperature behaviour of the motor. An external fan is not necessarily required in low output speed ranges.

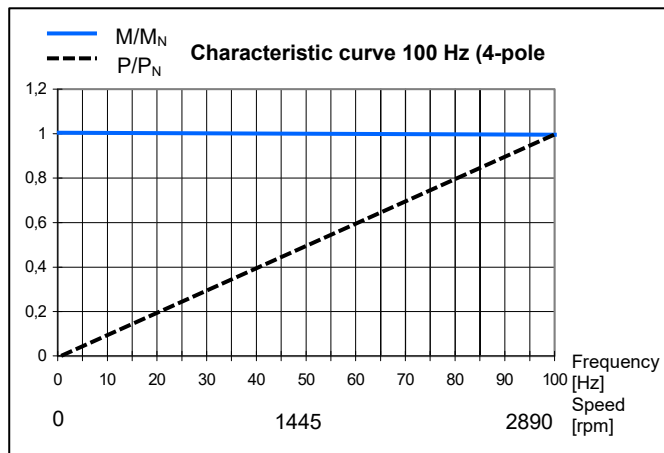

Figure 22: Characteristic curve 100 Hz

Information

The following motor data applies to standard motors with a 230 / 400 V winding. Please note that these specifications may vary slightly, as the motors are subject to certain manufacturing tolerances. It is recommended to have the resistance of the connected motor calibrated by the frequency inverter (P208 / P220).

Motor (IE1) SK ...	Frequency inverter SK 1x0E-...	M _N ¹⁾ [Nm]	Motor data for parameterisation							
			F _N [Hz]	n _N [min-1]	I _N [A]	U _N [V]	P _N [kW]	cos φ	Y/Δ	R _{st} [Ω]
63S/4	250-340-	0,90	100	2880	0,95	400	0,25	0,63	Δ	47,37
63L/4	370-340-	1,23	100	2895	1,07	400	0,37	0,71	Δ	39,90
71L/4	550-340-	1,81	100	2900	1,59	400	0,55	0,72	Δ	22,85
80S/4	750-340-	2,46	100	2910	2,0	400	0,75	0,72	Δ	15,79
80L/4	111-340-	3,61	100	2910	2,8	400	1,1	0,74	Δ	10,49
90S/4	151-340-	4,90	100	2925	3,75	400	1,5	0,76	Δ	6,41
90L/4	221-340-	7,19	100	2920	4,96	400	2,2	0,82	Δ	3,99

Notice: A comma counts as a full stop and signifies a decimal place.

1) At the rating point

Motor (IE2) SK ...	Frequency inverter SK 1x0E-...	M _N ¹⁾ [Nm]	Motor data for parameterisation							
			F _N [Hz]	n _N [rpm]	I _N [A]	U _N [V]	P _N [kW]	cos φ	Y/Δ	R _{St} [Ω]

Notice: A comma counts as a full stop and signifies a decimal place.

80SH/4	750-340-	2,44	100	2930	1,9	400	0,75	0,7	Δ	9,34
80LH/4	111-340-	3,60	100	2920	2,56	400	1,1	0,73	Δ	6,3
90SH/4	151-340-	4,89	100	2930	3,53	400	1,5	0,79	Δ	4,96
90LH/4	221-340-	7,18	100	2925	4,98	400	2,2	0,79	Δ	3,27

1) At the rating point

Motor (IE3) SK ...	Frequency inverter SK 1x0E-...	M _N ¹⁾ [Nm]	Motor data for parameterisation							
			F _N [Hz]	n _N [min ⁻¹]	I _N [A]	U _N [V]	P _N [kW]	cos φ	Y/Δ	R _{St} [Ω]

Notice: A comma counts as a full stop and signifies a decimal place.

63 SP/4	250-340-	0,59	100	2885	0,58	400	0,18	0,61	Δ	66,7
63 LP/4	250-340-	0,82	100	2910	0,83	400	0,25	0,56	Δ	39,7
71 SP/4	370-340-	1,20	100	2920	1,01	400	0,37	0,69	Δ	24,0
71 LP/4	550-340-	1,79	100	2925	1,34	400	0,55	0,72	Δ	17,7
80 SP/4	750-340-	2,44	100	2935	1,77	400	0,75	0,73	Δ	10,4
80 LP/4	111-340-	3,58	100	2930	2,13	400	1,1	0,84	Δ	6,50
90 SP/4	151-340-	4,86	100	2945	3,1	400	1,5	0,79	Δ	4,16
90 LP/4	221-340-	7,17	100	2930	4,33	400	2,2	0,83	Δ	3,15

1) At the rating point

8.9 Motor data – characteristic curves (synchronous motors)

When operating the motor on a NORDAC frequency inverter, use the motor data listed in the corresponding motor data sheet to parameterise the motor data. The motor data sheet is available from NORD or can be requested from NORD.

For the assignments of the motors to a frequency inverter, refer to  [B5000](#).

8.10 Scaling of set-/actual values

The following table contains details for the scaling of typical set-/actual values. These details relate to parameter (P400), (P418), (P543), (P546), (P740) or (P741).

Designation {Function}	Analogue signal		Bus signal					
	Value range	Scaling	Value range	Max. value	100% =	-100% =	Scaling	Limit absolute
Set point frequency { 1 }	0-10 V (10 V = 100%)	P104 ... P105 (min - max) P104+(P105-P104) *U _{AIN} [V]/10 V	±100%	16384	4000h 16384	C000h -16384	4000h * f _{sol} [Hz]/P105	P105
Frequency addition { 2 }	0-10 V (10 V = 100%)	P410 ... P411 (min - max) P410+(P411-P410) *U _{AIN} [V]/10 V	±200%	32767	4000h 16384	C000h -16384	4000h * f _{sol} [Hz]/P411	P105
Frequency subtract. { 3 }	0-10 V (10 V = 100%)	P410 ... P411 (min - max) P410+(P411-P410) *U _{AIN} [V]/10 V	±200%	32767	4000h 16384	C000h -16384	4000h * f _{sol} [Hz]/P411	P105
Minimum frequency { 4 }	0-10 V (10 V = 100%)	50 Hz* U _{AIN} [V]/10 V	0 ... 200% (50Hz=100%)	32767	4000h 16384	/	4000h * f _{min} [Hz] / 50 Hz	P105
Maximum frequency { 5 }	0-10 V (10 V = 100%)	100 Hz* U _{AIN} [V]/10 V	0 ... 200% (100Hz=100%)	32767	4000h 16384	/	4000h * f _{max} [Hz] / 100 Hz	P105
Cur.val process ctrl { 6 }	0-10 V (10 V = 100%)	P105* U _{AIN} [V]/10 V	±200%	32767	4000h 16384	C000h -16384	4000h * f _{sol} [Hz]/P105	P105
Nom.val process ctrl { 7 }	0-10 V (10 V = 100%)	P105* U _{AIN} [V]/10 V	±200%	32767	4000h 16384	C000h -16384	4000h * f _{sol} [Hz]/P105	P105
Torque current limit { 11 }, { 12 }	0-10 V (10 V = 100%)	P112* U _{AIN} [V]/10 V	0 ... 100%	16384	4000h 16384	/	4000h * Torque [%] / P112	P112
Current limit { 13 }, { 14 }	0-10 V (10 V = 100%)	P536* U _{AIN} [V]/10 V	0 ... 100%	16384	4000h 16384	/	4000h * Current limit [%] / (P536 * 100 [%])	P536
Ramp time { 15 }	0-10 V (10 V = 100%)	10 s* U _{AIN} [V]/10 V	0 ... 200%	32767	4000h 16384	/	4000h * Ramp time [s] / 10 s	20s
When specified via bus, the ramp time must not be set at the same time as the enable removal. It must be set beforehand. Otherwise, the old ramp time is used to calculate the disconnection control. This may result in error 13.2.								
Actual values {Function}								
Actual frequency { 1 }	0-10 V (10 V = 100%)	P201* U _{AOut} [V]/10 V	±100%	16384	4000h 16384	C000h -16384	4000h * f [Hz]/P105	
Speed { 2 }	0-10 V (10 V = 100%)	P202* U _{AOut} [V]/10 V	±200%	32767	4000h 16384	C000h -16384	4000h * n [rpm]/P202	
Current { 3 }	0-10 V (10 V = 100%)	P203* U _{AOut} [V]/10 V	±200%	32767	4000h 16384	C000h -16384	4000h * I [A]/P203	
Torque current { 4 }	0-10 V (10 V = 100%)	P112* 100/ √((P203) ² - (P209) ²)* U _{AOut} [V]/10 V	±200%	32767	4000h 16384	C000h -16384	4000h * I _q [A]/(P112)*100/ √((P203) ² - (P209) ²)	
Freq. Master Value { 19 } ... { 24 }	/	/	±100%	16384	4000h 16384	C000h -16384	4000h * f [Hz]/P105	

8.11 Definition of set and actual value processing (frequencies)

The frequencies used in P502 / P543 are processed in various ways according to the following table.

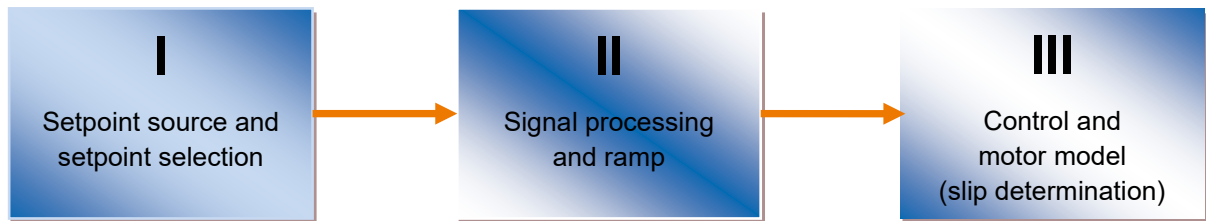

Func.	Name	Meaning	Output to ...			Without left/right	With slip
			I	II	III		
8	Set point frequency	Set point frequency from setpoint source	X				
1	Actual frequency	Set point frequency before motor model		X			
23	Act. freq. With slip	Actual frequency on the motor			X		X
19	Freq. Master Value	Set point frequency from setpoint source Master value (freed from enable direction)	X			X	
20	Set Freq. After Ramp	Set point frequency before motor model Master value (freed from enable direction)		X		X	
24	Lead.act.freq.+slip	Actual frequency on the motor Master value (freed from enable direction)			X	X	X
21	Act. Freq. w/o Slip	Actual frequency without slip Master value			X		

Table 17: Set and actual value processing in the frequency inverter

9 Maintenance and servicing information

9.1 Maintenance information

NORD frequency inverters are *maintenance-free* in normal operation(see chapter 7 "Technical data").

Dusty environments

If the device is operated in dusty air, the cooling surfaces must be cleaned with compressed air at regular intervals.

Long-term storage

Information

Climatic conditions for long-term storage

- Temperature: +5 to +35°C
 - Relative humidity: < 75%
-

The device must be connected to the supply network for at least 60 minutes each year. During this time, the device must not be loaded at either the motor or control terminals.

If these steps are not taken, this may result in destruction of the device.

Information

Accessories

The regulations for **long-term storage** apply to the accessories, such as 24 V power supply modules (SK xU4-24V-..., SK TU4-POT-...), and the electronic brake inverter (SK CU4-MBR) likewise.

9.2 Service notes

In case of service/repair, contact your NORD Service contact person. You will find your contact person listed on your order confirmation. Additionally, you will find further possible contact persons using the following link: <https://www.nord.com/de/global/locator-tool.jsp>.

When contacting our technical support please have the following information available:

- Device type (name plate / display)
- Serial number (name plate)
- Software version (parameter P707)
- Information regarding accessories and options used

If you would like to send the device in for repair please proceed as follows:

- Remove all non-original parts from the device.

NORD accepts no liability for any attached parts such as power cables, switches or external displays!

- Back up the parameter settings before sending in the device.
- State the reason for sending in the component / device.
 - You can obtain a return note from our web site ([Link](#)) or from our technical support.
 - In order to rule out the possibility that the device fault is caused by an optional module, the connected optional modules should also be returned in case of a fault.
- Specify a contact person for possible queries.



Information

Factory settings of parameters

Unless otherwise agreed, the device is reset to the factory settings after inspection/repair.

The manual and additional information can be found on the Internet under www.nord.com.

9.3 Disposal

NORD products are made of high-quality components and valuable materials. Therefore, have faulty or defective appliances checked to see if they can be repaired and reused.

If repair and reuse is not possible, observe the following disposal notes.

9.3.1 Disposal according to German law

- The components are marked with the crossed-out waste bin according to the “Electrical and Electronic Equipment Directive – ElektroG3” (dated 20 May 2021, valid from 1 January 2022).



The appliances must therefore not be disposed of as unsorted municipal waste, but must be collected separately and handed to a WEEE (Waste of Electrical and Electronic Equipment) registered collection point.

- The components do not contain any electrochemical cells, batteries or accumulators, which must be separated and disposed of separately.
- In Germany, NORD components can be handed in at the headquarters of Getriebbau NORD GmbH & Co. KG.

WEEE Reg. No.	Name of the manufacturer / authorised representative	Category	Appliance type
DE12890892	Getriebbau NORD GmbH & Co. KG	Appliances where at least one of the outer dimensions exceeds 50 cm (large appliances)	Large appliances for exclusive use in other than private households
		Appliances where none of the outer dimensions exceeds 50 cm (small appliances)	Small appliances for exclusive use in other than private households

- Contact: info@nord.com

9.3.2 Disposal outside of Germany

Outside Germany, please contact the local subsidiaries or distributors of the NORD DRIVESYSTEM Group.

9.4 Abbreviations

AIN	Analogue input	FI (switch)	Leakage current circuit breaker
AS-i (AS1)	AS Interface	FI	Frequency inverter
ASi (LED)	Status LED – AS interface	I/O	In / Out (Input / Output)
ASM	Asynchronous machine, asynchronous motor	ISD	Field current (Current vector control)
AOUT	Analogue output	LED	Light-emitting diode
AUX	Auxiliary (voltage)	LPS	List of planned slaves (AS-I)
BR	Braking resistor	P1 ...	Potentiometer 1 ...
DI (DIN)	Digital input	PMSM	Permanent magnet synchronous machine / -motor
DigIn		PLC / SPS	Programmable Logical Controller
DS (LED)	Status LED – device status	PELV	Safety low voltage
CFC	Current Flux Control (current-controlled, field-oriented control)	S	Supervisor Parameter, P003
DO (DOUT)	Digital output	S1...	DIP switch 1 ...
DigOut		SW	Software version, P707
I / O	Input /Output	TI	Technical information / Data sheet (Data sheet for NORD accessories)
EEPROM	Non-volatile memory	VFC	Current Flux Control (current-controlled, field-oriented control)
EMKF	Electromotive force (induction voltage)		
EMC	Electromagnetic compatibility		

Key word index

3

3-wire control 125, 126

A

Absolute mini. freq. (P505)..... 136

Acceleration time (P102).....95

Actual

cos phi (P725)..... 155

current (P719)..... 154

field current (P721) 154

frequency (P716) 154

Speed (P717)..... 154

torque current (P720)..... 154

voltage (P722)..... 154

Actual

Mains current (P760) 160

Actual bus value 1 ... 3 (P543) 146

Actual value processing Frequencies.....208

Actual values 207

Additional parameters..... 134

Adjustment 0% (P402)..... 119

Adjustment 100% (P403)..... 120

Adjustment range

1/10 200, 203, 205

Analog input mode (P401)..... 117

Analog input voltage (P709) 152

Analogue input filter (P404)..... 121

Analogue output voltage (P710)..... 153

Apparent power (P726) 155

AS-Interface..... 82

Assembly

SK 1x0E 30

ATEX 18, 22, 35, 53

Optional ATEX modules.....55

ATEX

ATEX Zone 22, Cat. 3D 53

ATEX

EU conformity declaration.....59

Automatic error acknowledgement P506.... 136

Automatic flux optimisation 199

Automatic flux optimisation (P219) 107

Automatic starting (P428) 128

B

Basic parameter 95

Boost precontrol (P215)..... 106

Brake chopper..... 40

Brake control..... 97, 101

Brake reaction time (P107) 97

Brake release time (P114) 101

Brake resistor (P556)..... 149

Brake resistor type (P557) 149

Braking distance 99

Braking resistor 40, 178

Bus

Setpoint (P546) 147

Bus I/O In Bits 132

Bus I/O Out Bits 132

Bus setpoints 147, 148

Bus status via PLC (P353)..... 113

C

CAN address (P515)..... 138

CAN bus baud rate (P514) 138

CAN master cycle (P552) 148

CANopen status (P748)..... 159

CE mark 185

Characteristic curve setting 104

Characteristics 12

Charging error 170

Configuration level (P744) 158

conformity declaration

ATEX 59

Control connection 49

Control options 61, 62, 89, 162

Control parameters 110

Control terminals 50, 115

Control unit connection	49	Efficiency	173
Copy parameter set (P101)	95	Electrical data	176
CSA	176	1/3~230 V	178
cUL	176	Electrical data	
Current		1~ 115 V	177
DC brake (P109)	100	Electrical data	
phase U (P732)	155	3~ 400 V	180
phase V (P733)	156	EMC Directive	45, 185
phase W (P734)	156	Emerg. stop on error (P427)	127
Current limit (P536)	143	EMF voltage PMSM (P240)	108
Current vector control	107	Emission of interference	188
Curve setting	105, 107	EN 55011	186
Customer unit	64	EN 61000	188
D		EN 61800-3	186
Database version (P742)	158	Enable period (P715)	153
DC Brake	99	Energy efficiency	173
DC braking time On (P110)	100	Energy Efficiency	199
DC link voltage (P736)	156	Environmental standard	186
DC Run-on time (P559)	150	Error messages	161, 162
Deceleration time (P103)	95	EU conformity declaration	
delay on/off switch (P475)	131	ATEX	59
Derating	30	EU Declaration of Conformity	185
Digital functions	124	F	
Digital inputs (P420)	124	Factor I ² t-Motor	142
Digital output		Factory setting (P523)	140
function (P434)	128	Factory settings	72
Hysteresis (P436)	130	FAQ	
Scaling (P435)	129	Operational problems	171
Dimensions	33	Faults	161, 162
DIP switches	77	Field (P730)	155
Direct current braking	99	Field current controller I (P316)	111
Disconnection mode (P108)	99	Field current controller P (P315)	111
Display	61	Field weakening controller I (P319)	112
Display factor (P002)	94	Field weakening controller P (P318)	112
Display selection (P001)	93	Field weakening limit (P320)	112
Disposal	211	Filter	
Distance calculator	99	Analog output 1 (P418)	123
Dynamic boost (P211)	105	Fixed frequencies mode (P464)	130
Dynamic braking	40	Fixed frequency array (P465)	131
E		Flux delay (P558)	149
EAC Ex	18, 22, 35, 53	Flying start (P520)	139

Flying start offset (P522)	139	Linear V/f characteristic curve	107
Flying start resolution (P521).....	139	Link circuit last error (P705).....	151
Function		Load drop.....	97
Bus I/O In Bits (P480)	132	Load factory setting.....	140
Bus I/O Out Bits (P481)	132	Load monitoring	133, 141
Setpoint inputs (P400)	115	Load monitoring	133
Fuse protection.....	177	Load monitoring	
G		Maximum (P525).....	140
Gateway.....	63	Load monitoring	
H		Minimum (P526).....	140
Heatsink temperature (P739)	156	Load monitoring	
Hysteresis of bus I/O Out bits (P483).....	134	frequency (P527).....	140
I		Load monitoring	
I ² t limit	163	delay (P528).....	141
I ² t motor (P535)	143	Load monitoring mode (P529)	141
Immunity from interference.....	188	M	
Inductivity PMSM (P241)	109	M12	
Information.....	150	Connector.....	69
Input voltage (P728)	155	Flanged connector.....	69
Installation altitude.....	173	Maintenance	209
Internet.....	210	Master - Slave.....	135
Inverter name (P501).....	134	Master function	135
Inverter type (P743).....	158	Master function output (P503)	135
Inverter voltage range (P747).....	158	Master function value (P502).....	135
IP protection class	29	Maximum frequency (P105).....	96
ISD control	107	Maximum frequency auxiliary setpoint (P411)	
J		121
Jog frequency (P113)	100	Mechanical power (P727)	155
K		Menu group.....	89
KTY84-130	79	Messages.....	161, 162
L		Min.freq. process cont. (P466).....	131
Last current error (P703)	151	Minimum frequency (P104).....	96
Last fault (P701)	151	Minimum frequency auxiliary setpoint (P410)	
Last frequency error (P702).....	151	121
Leakage current.....	173	Modulation depth (P218)	106
LEDs	161, 162	Module status(P746).....	158
Lifting gear with brake	97	Monitoring	
Limit		Motor temperature.....	79
Field current controller (P317)	111	Motor	
Torque current controller (P314).....	111	Cos phi (P206)	103
		Nominal voltage (P204).....	103

Motor	P set last error (P706).....	152
Nominal current (P203).....	Par.-identification (P220)	108
Nominal frequency (P201)	Parameter identification	108
Nominal speed (P202)	Parameter set (P100).....	95
Motor	Parameter set (P731).....	155
Nominal power (P205)	Parameter, saving mode (P560).....	150
Motor	Parametrisation options	61, 62, 89, 162
Star Delta con. (P207)	Peak current PMSM (P244).....	109
Motor Assembly.....	PI control I-component (P414).....	121
Motor data.....	PI control P-component (P413)	121
72, 102, 200, 203, 205	PI process controller	183
Motor list (P200)	PLC display value (P360)	114
Motor temperature monitoring	PLC functionality (P350)	113
79	PLC Integer setpoint (P355)	114
Mounting of optional module	PLC Long setpoint (P356)	114
38	PLC setpoint (P553).....	148
N	PLC setpoint selection (P351)	113
Name plate	PLC Status (P370).....	114
26, 72	Plug connectors for control connection.....	69
No-load current (P209).....	Plug connectors for power connections.....	68
104	Plug connectors:	68
Nom. val. process ctrl. (P412)	PotentiometerBox function (P549).....	147
121	Power limit	191
O	Power rating / Motor size	28
Offset analogue output 1 (P417)	Present	
122	fault (P700).....	150
Op.-time last error (P799).....	operating status (P700).....	150
160	Setpoint frequency (P718)	154
Operating display (P000).....	warning (P700)	150
93	Process controller	115, 131, 183
Operating displays.....	Process controller control limit (P415).....	121
93	Process data Bus In (P740).....	157
Operating mode.....	Process data Bus Out (P741)	157
177	Product standard.....	186
Operating status	Protection class.....	173
161, 162	Pulse disconnection.....	142, 144
Operating time	Pulse disconnection (P537).....	144
153	Pulse frequency (P504)	136
Operating time (P714)	Q	
153	Quick stop time (P426)	127
Operation		
61		
Option (mounting) locations.....		
36		
Option monitoring (P120)		
101		
Oscillation damping (P217)		
106		
Oscillation damping PMSM (P245)		
109		
Outdoor installation.....		
60		
Output monitoring (P539)		
144		
Overcurrent.....		
163		
Overtemperature		
163		
Overvoltage		
164		
Overvoltage switch-off.....		
40		
P		
P chopper limit (P555).....		
149		
P factor torque limit (P111).....		
100		

R	
Ramp smoothing (P106).....	97
Ramp time PI setpoint (P416)	122
Rating point	
50 Hz.....	200, 205
50Hz.....	203
RCD	195
Reason FI disabled (P700).....	150
reduced output power.....	191
Relays	
Set (P541).....	145
Reluct. angle IPMSM (P243).....	109
Retrofitting the device.....	31
Rotation direction.....	145
Rotation direction mode (P540).....	145
Rotor starting position detection (P330).....	112
S	
Scaling	
Bus I/O In Bits (P482).....	133
Set-/actual values	207
Scope of delivery	14
Servo mode (P300)	110
Set analogue output (P542).....	146
Set digital output (P541).....	145
Setpoint processing	154, 182
Setpoint processing Frequencies	208
Setpoint source (P510).....	137
Setpoints.....	207
SK BRE4-	41, 42
SK BREW4-	41, 42
SK BRI4-	40, 42
SK BRW4-	41
SK CU4-POT	71
SK TIE4-WMK-	34
Skip frequency 1 (P516).....	138
Skip frequency 2 (P518).....	139
Skip frequency area 1 (P517).....	139
Skip frequency area 2 (P519).....	139
Slip compensation (P212)	105
Software version (P707).....	152
Source control word (P509).....	137
Speed controller I (P311).....	110
Speed controller P (P310)	110
Standardisation	
Analogue output 1 (P419)	124
State of relays (P711)	153
Static boost (P210)	104
Statistic	
Mains failure (P752)	159
Overcurrent (P750).....	159
Overvoltage (P751)	159
Statistics	
Customer error (P757)	160
Overheating (P753)	159
Parameter loss (P754)	160
System faults (P755).....	160
Time out (P756).....	160
Stator resistance (P208)	104
Status	
Digital input (P708).....	152
DIP switches (P749).....	159
Storage	173, 209
Supervisor code (P003)	94
Switch-on cycles	173
Switchover freq.VFC PMSM (P247)	109
System bus	137, 138, 196
System bus tunnelling.....	63
T	
Technical data.....	30, 46, 47, 173, 209
Technical data	
Frequency inverter	173
Technical data	
Frequency inverter	195
Technology unit.....	65
Telegram timeout (P513)	138
Temperature sensor.....	79
Three-phase standard motor	102
Time boost precontrol (P216)	106
Torque (P729).....	155
Torque current controller I (P313).....	111
Torque current controller P (P312)	111
Torque current limit (P112)	100

Torque disconn. limit (P534).....	142	Vector control.....	107
Torque precontrol (P214)	105	Ventilation	30
Total currents.....	49	Voltage –d (P723).....	154
Type code	25	Voltage last error (P704).....	151
U		Voltage –q (P724).....	154
UL/CSA approval.....	176	W	
Usage rate brakeres. (P737)	156	Wall-mounting	34
Usage rate Motor (P738).....	156	Warning messages	150, 168
USS address (P512).....	137	Warnings.....	150, 161, 162, 168
USS baud rate (P511)	137	Watchdog.....	130
V		Watchdog time (P460).....	130
Var. ISD control (P213)	105	Weight.....	33
		Wiring guidelines.....	45

Headquarters
Getriebebau NORD GmbH & Co. KG
Getriebebau-Nord-Str. 1
22941 Bargteheide, Deutschland
T: +49 45 32 / 289 0
F: +49 45 32 / 289 22 53
info@nord.com