

Intelligent Drivesystems

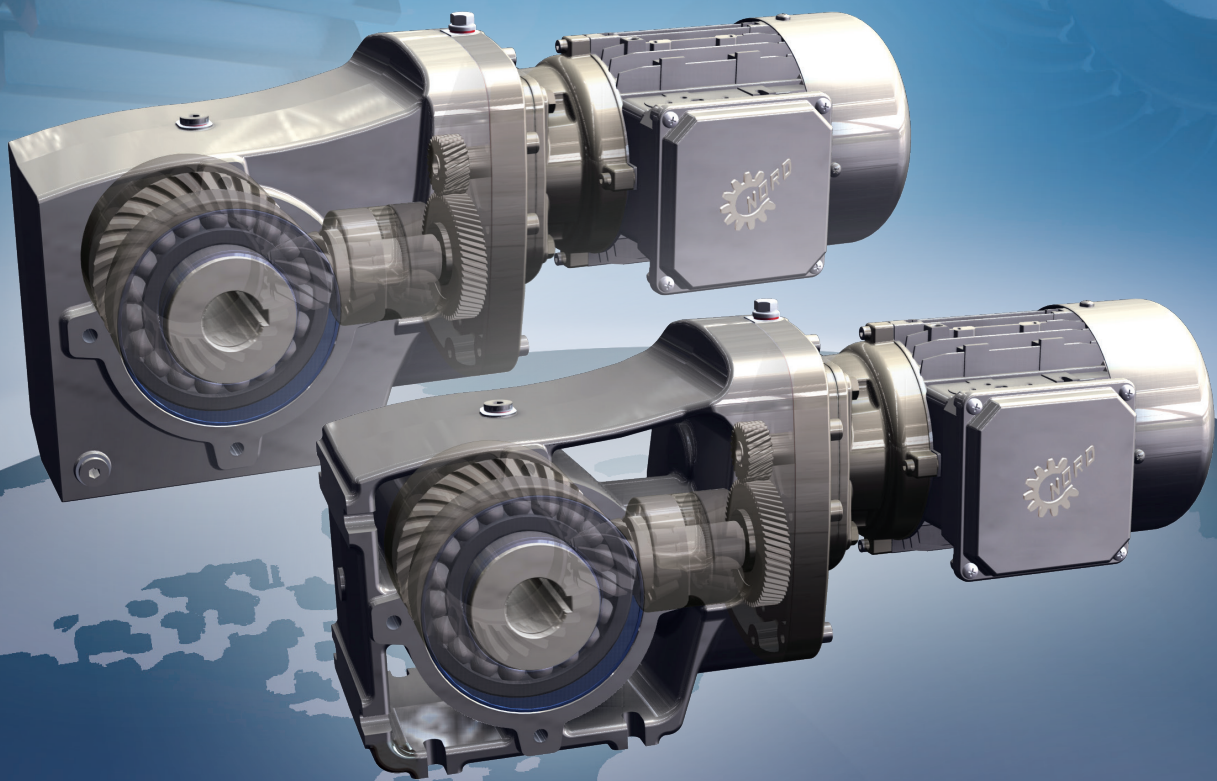

## 2 STAGE HELICAL-BEVEL GEARMOTORS & SPEED REDUCERS

Durable & Premium Efficient Gear Units

G1014

  
DRIVESYSTEMS

# 2 Stage Helical-Bevel Innovative Design

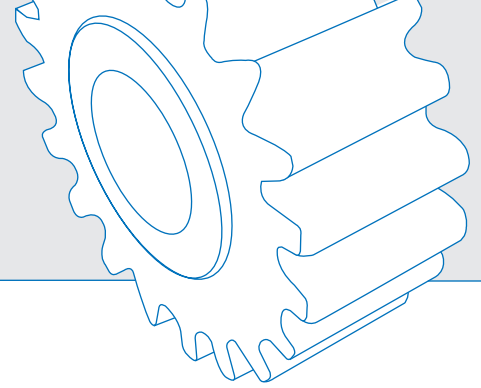

## 92.1 and 93.1 Two-stage helical bevel Product Introduction

NORD 2-Stage Right-Angle Helical-Bevel reducers are manufactured from aluminum alloy using the latest in FEM (Finite Element Modeling) technology. The UNICASE® housing needs no assembly covers or screws. Manufacturing precision ensures accurate alignment of all bearing seats, internal shafts and gears. Modular design, with oversized output bearings, helps to simplify assembly, ensure serviceability and fast delivery, while providing generous bore capacity and high radial load ratings. Flexible design allows for a variety of input configurations, output and mounting options. The SK 92.1 and SK 93.1 units include identical ratings and ratios with varied housing designs.

## 92.1 and 93.1 Benefits

- Up to 97% efficiency
- Large high-capacity bearings
- Increased Hollow Bore Capacity
- High Strength Aluminum Housing
- NEMA, IEC or Solid Shaft Input As Standard
- UNICASE Housing Design
- Increase Overhung Load
- FEM (Finite Element Modeling)
- Corrosion-Resistant
- Accommodates C-Face motors or brakemotors

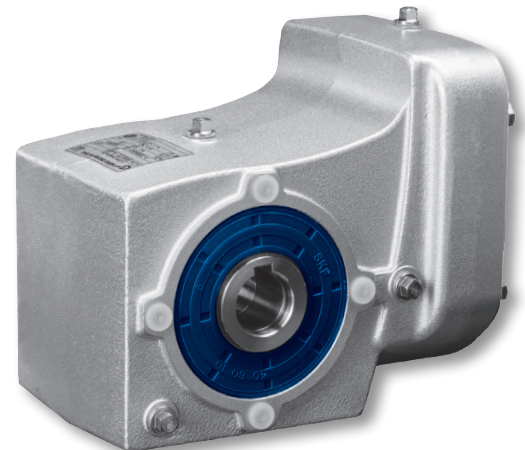
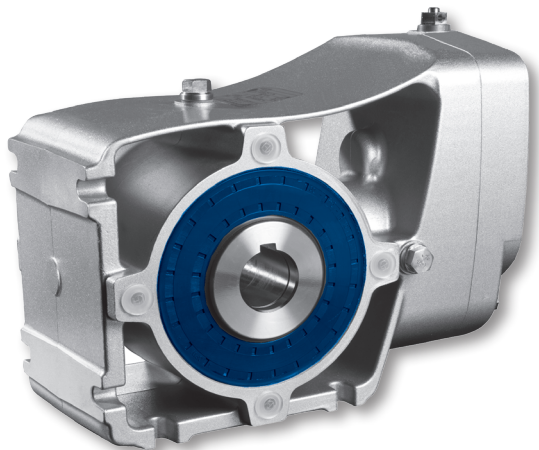

## 92.1 Series Helical-Bevel

The 92.1 series, easily identified by its open design, is a universal housing offering foot, face (B14) and shaft mount as standard. An optional B5 mount is available. The 92.1 series is a cost effective when compared to the 93.1 and is ideal for cooling due to large surface area.

### Key Features:

- Universal foot and flange-mount housings
- Easy Wash-Down Solution
- Cost effective design
- Foot, face (B14) and shaft mount
- External surfaces connected with large radius and generous mold release slopes provide for a cleanable, drainable housing

## 93.1 Series Helical-Bevel

The 93.1 series is characterized by the closed design and comes as shaft and flange mount (B14) as standard. Optional drilled and tapped holes can be provided for foot mount requirements. In addition, an optional screw B5-Flange is readily available. Because there are no cavities to this design, NSD tupH surface conversion system is available.

### Key Features:

- Closed gearbox design
- No hidden chambers (cavities) for material build-up
- Optimal for NSD tupH Surface Conversion System
- Ideal for sanitary or washdown environments
- B14 flange and optional tapped foot holes available



# Table of Contents



<b>Introduction</b> .....	2
Company Information.....	2
Key Features .....	4
Selection.....	11
General Warnings & Cautions.....	13
Mounting Positions .....	16
Options.....	20
Lubrication .....	32
Service Factoring.....	51
<b>Ratings</b> .....	61
Gearmotor Selection .....	61
Reducer Selections & Combinations .....	83
Dimensions.....	61
Alternate Shaft Options.....	140
<b>Motors</b> .....	145
Order Form.....	146
Standard Design .....	149
Options.....	153
Performance Data .....	168
<b>Brakes</b> .....	201
<b>Contacts</b> .....	261
<b>Terms &amp; Conditions of Sale</b> .....	270



[www.nord.com](http://www.nord.com)

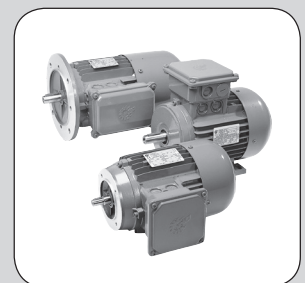
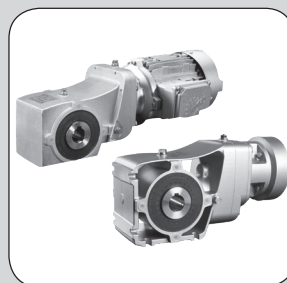
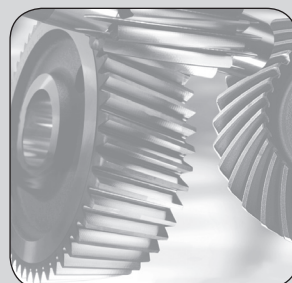



## Company Overview



Since 1965, NORD has become well established in the power transmission industry and grown to global proportions on the strength of product performance, superior customer service, and intelligent drive solutions.

NORD designs and manufactures drivesystems engineered for adaptability. NORD's improving, expanded and innovative drive solutions are specified and utilized for a range of applications in nearly every industry throughout the world.

NORD Drivesystems' product portfolio is extensive and continuously evolving in order to meet the needs of today's fast-changing markets. NORD's range of drive equipment includes: helical in-line, helical shaft-mount, helical-bevel, helical-worm and worm gear units with torques from 90 lb-in to 2,200,000 lb-in, readily available AC motors from 1/6 HP to 250 HP, variable frequency drives up to 250 HP, & mechanical variable speed drives.

NORD does far more than manufacture the world's finest drive components. We provide our customers with optimum drive configurations for their specific purposes, providing each and every one with truly complete and efficient systems at a price/quality ratio unmatched in today's competitive markets.

## Short, On-Time Delivery

As a NORD customer, you can rest assured that your order will be delivered on time. Because NORD has both decentralized assembly and manufacturing operations and a linked global network, we offer our customers:

- Fast, reliable delivery
- Greater product versatility
- Shorter lead times
- Timely shipping
- Global Availability

## Global Availability



NORD makes its wide product range easily available through a global network that includes representation in over 60 countries. Providing all customers with prompt delivery, and expert support services, we are firmly committed to exceeding customer expectations and being totally responsive to the ideas and specifications of every customer, anywhere in the world.

## Increased North American Presence

NORD covers North America with over 30 district offices and over 500 distributor branches. NORD operates a manufacturing and assembly facility in Waunakee, WI, Charlotte, NC, Corona, CA, Brampton, ON, and Monterrey, Mexico, resulting in an ever-increasing capacity in the United States and Canada and giving our customers the shortest lead times in the industry.



**Manufacturing**

NORD Gear continually invests in the latest research, manufacturing and automation technology. This ensures our ability to provide you with the utmost quality at an affordable price. Not only do we invest in our North American facilities, we invest in our factories throughout the world. We continually try to improve our practices to provide our customers with the most superior product available.



**Quality**

Quality is assured at NORD assembly and manufacturing facilities, based on ISO 9000 standards — from careful inspection of incoming materials to closely monitored machining operations including gear cutting, turning, hardening & grinding as well as finishing and assembly.

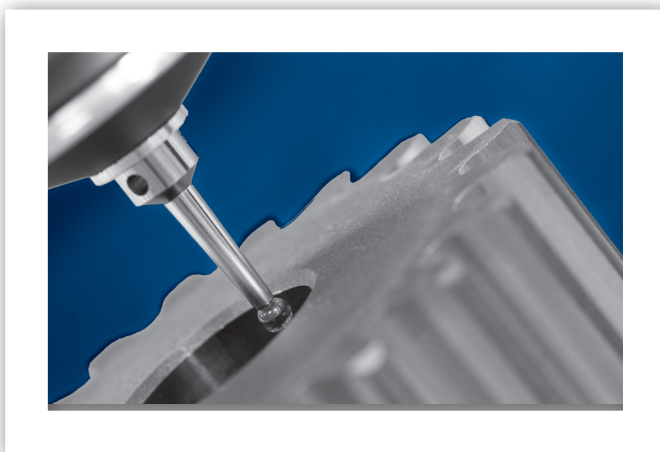

**Worldwide Standards**

NORD products are designed and manufactured based on the latest North American and global standards.



**Energy Efficiency**

Lowering your operating costs is one of our greatest goals! NORD research and development focuses on energy efficiency, with gearboxes, motors, and frequency inverters designed for lower energy consumption. Our fully diverse line of in-line or right-angle units and motors has been developed to suit your needs.



**NORD 911**

Trouble? Just call 715-NORD-911 (in Canada, 905-796-3606). Emergency service is available 24 hours a day, 7 days a week. We'll answer your call, ship the parts, or build a unit and have it shipped directly to you to provide what you need, when you need it.



INTRODUCTION



# Key Features



INTRODUCTION

## 2-Stage Helical-Bevel Overview



NORD has improved their unique class of high performance right-angle speed reducers. Our two-stage helical-bevel drives are available as gearmotors and speed reducers with many mounting options. These units provide high performance right-angle helical-bevel gear units at the cost effectiveness of a single worm system.

### 2-Stage Helical-bevel Units

SK 92072.1	SK 93072.1
SK 92172.1	SK 93172.1
SK 92372.1	SK 93372.1
SK 92672.1	SK 93672.1
SK 92772.1	SK 93772.1

The 92.1 and 93.1 housings, are available in five sizes per series, and are a heavy duty one-piece UNICASE® design. Featuring a corrosion-proof aluminum die-cast housing, a 60% increase in torque to weight ratio has been accomplished over our previous series. The die-cast and sand-blasted housing provides an extremely smooth surface finish. External surfaces, connected with large radius and generous mold release slopes, provide exceptional drainage with no hidden chambers or small pockets. Material build-up areas have been decreased, resulting in easy cleaning and draining of dirt and liquids. Designed using FEM (Finite Element Modeling), the single piece, high strength aluminum alloy housing needs no assembly covers and screws. NORD's manufacturing precision ensures an accurate alignment of all bearing seats, internal shafts and gears.

## 2-Stage Helical-bevel Advantages When Compared to Other Helical-Bevel Designs

- The cost is up to 40% lower than traditional helical-bevel designs
- There are lower gear ratios available that produce higher output speeds.
- The 92.1 & 93.1 offering is a true helical-bevel offering, designed for high energy efficiency.

## NORD 2-Stage Helical-bevel Advantages When Compared to Single Worm Units

- **Premium efficiency** – 97% gear efficiency compared to 40-90% of worm units (depending on the ratio)
- **Long gear life** – NORD's 2-stage Helical-bevel gearing is wear-free for infinite life – worms are generally designed to need replacement.
- **Many more ratios** – over 21 ratios per case size vs. worm's 9 ratios up to 60:1. May reduce the need for additional components – belts, chains, guards...
- **UNICASE™ quiet leak-free design** – The UNICASE™ system eliminates splits or bolt-ons that may weaken housings and aid oil leakage.
- **Runs cooler due to the high efficiency** – worm gear units tend to generate more heat and we believe to have found a solution to that trend with our high efficiency ratings.
- **NORD motor advantages** - inverter/vector duty motors than may be provided with, many options: brakes, encoders, forced vent fans....

## Concepts that Helped Achieve this Innovative Product

**Optimal computerized design** – NORD has invested in the latest design and manufacturing tools to ensure maximum performance and price. From design to product, NORD delivers innovation geared towards a solution for our customers, promising a long service life.

**Reduced parts counts** – Most helical-bevel reducers are 3-stage gear units; a helical input, a middle bevel stage, and the final helical stage. NORD has recently optimized our two-stage helical-bevel reducer: first stage helical and output stage bevel. This reduces the number of parts required to build a gear unit - 2 fewer gears, 2 fewer bearings, 1 less shaft, and fewer spacers and shims. This allows NORD to achieve significant cost reduction while maintaining the ultra high quality of a helical-bevel design.

**Optimized for the food industry** – The lightweight, aluminum housing incorporates the newest in manufacturing technology. Mold release slopes guarantee the draining of cleaning liquid in all mounting positions. By adding our exclusive NSD<sup>tupH</sup> surface conversion system, wash down liquids always run off. The benefits of NSD<sup>tupH</sup> include no peeling, flaking or blistering of paint by providing a higher level of corrosion resistance. Our 2-stage Helical bevels are much lighter and offer better thermal conductivity than stainless steel. This allows for easier mounting and increased heat dissipation for your applications.



## 92.1 / 93.1 Helical-Bevel Product Features

### UNICASE™ - Aluminum Housing

Light weight, high strength, optimal heat dissipation and natural corrosion resistance. Eliminates bolt-ons that may weaken housings and aid in oil leakage.

### Lower Cost

Up to 40% lower than traditional helical-bevel designs

### Cooler Operating Temperatures

With high efficiencies and smooth body design our units dissipate heat much better than traditional worm drives.

### 2 Housing Styles

The 92.1 and 93.1 housing styles offer a multitude of mounting options and benefits to fit your application needs.

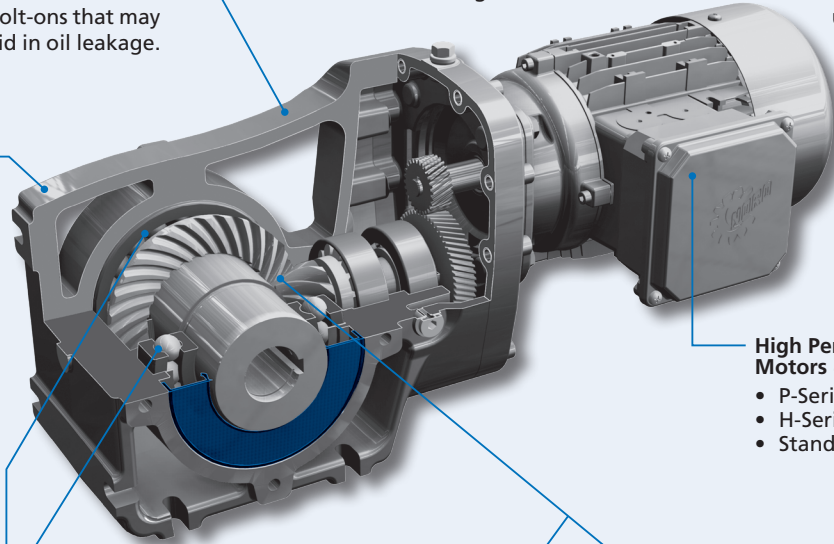

### High Performance Inverter Duty Motors & Brakemotors

- P-Series - Premium Efficient
- H-Series - Energy Efficient
- Standard Efficient

### Output Bearings

Oversized bearings provide high radial and axial load capacities and long service life.

### Long Gear Life

Infinite life wear free design. Our optimized spiral bevel gear geometries are quiet and smooth running.

### 97% Gear Efficiency

Gearing with ratings up to AGMA 13 quality.

## Standard NORD features

### Modular Design

All NORD products including the 92.1 & 93.1 Series bevel units are modular in design and provide extraordinary flexibility. The 92.1 & 93.1 Series bevel units provide great mounting versatility including:

- Foot mount
- Flange mount B5
- Face flange mount B14

The 92.1 & 93.1 Series bevel unit may also be provided with a number of different input configurations including:

- Integral motor (Gearmotor)
- NEMA C-face motor adapter
- IEC B5 motor adapter
- Solid input shaft
- Custom motor adapter (servo, hydraulic motors, and more)

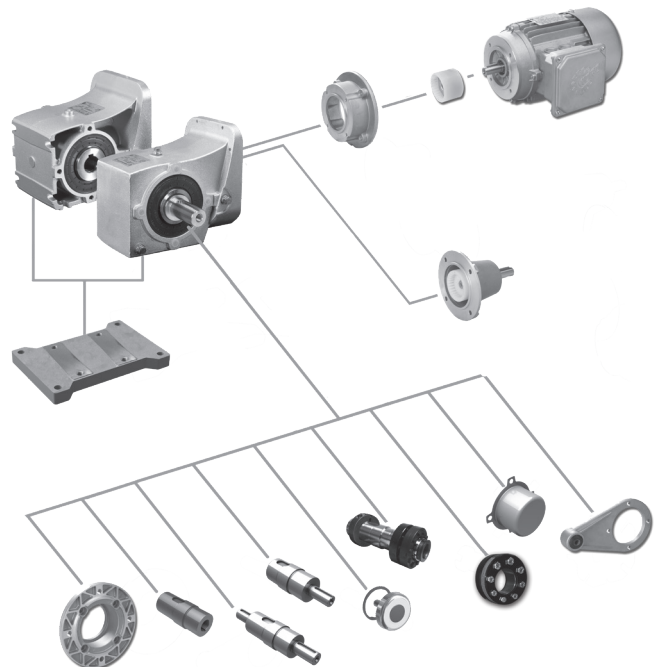

# Key Features



## UNICASE™ One-Piece Housing

NORD heavy-duty, one-piece housings are precisely machined to meticulous standards. Internal reinforcements further increase strength and rigidity. All bearings and seal seats are contained within the casting, eliminating splits or bolt-on carriers that can weaken the housing and allow oil leakage. Bores and mounting faces are machined in one step, producing extremely precise tolerances – thus ensuring accurate positioning of gear teeth, bearings and seals, and longer life for all components.

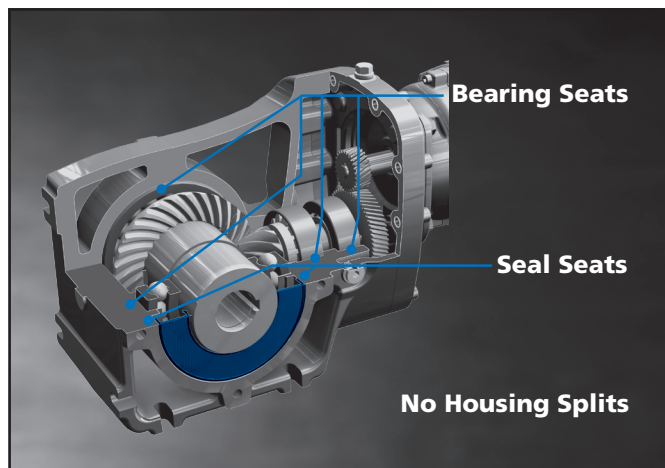

### Benefits

- Better value
- Higher efficiency
- Quieter operation
- Lower weight
- Longer life

## High-Quality Gearing (Infinite Life Design)

NORD continually invests in state-of-the-art gear production equipment and in gear research. This allows us to produce exceptionally high quality gears.

### Benefits

- Designed and manufactured up to AGMA CLASS 13
- Infinite design life
- Case-hardened steel
- Exceptional hardness: 58 Rc minimum
- High-speed gears are ground; low speed gears are skive hobbed
- 275% momentary overload capacity
- Low noise
- Low maintenance

## Aluminum Alloy Housing - High Strength, Light Weight, Corrosion-Resistant

The NORD modular 2-stage helical-bevel gear units are optimally designed with a high strength, light-weight aluminum alloy housing material. The oxidation layer that forms naturally on the aluminum alloy is inherently corrosion resistant in many applications, making paint and protective surface treatments optional. The aluminum alloy housing conducts heat better than cast iron, providing lower internal operating temperatures and ensuring increased service life for the lubricating oil, bearings, seals and gears. Additionally, a 60% increase in power density, compared to the previous generation, has been achieved.

- High strength to weight ratio
- Increased torque to weight rating by up to 60% over previous models
- Smooth surface finish with generous mold release slopes provide exceptional drainage
- Natural corrosion resistance.
- Lower internal operating temperatures.
- Developed for: Conveyor industry, Material Handling, Car Wash, Food & Beverage and Clean, or Wash Down, environments.

## Large Ratio Per Gear Stage

NORD gear cutting technology allows for the production of gear sets with a higher maximum ratio per stage than many other speed reducer manufacturers. NORD commonly produces gear sets with a maximum ratio of between 9:1 and 10:1 per stage. This allows for double reduction gear units with a maximum ratio between 70:1 and 100:1. Most speed reducer manufacturer's can only produce single-stage reduction of between 5:1 and 6:1. This means a two-stage reducer with a maximum reduction of about 25:1 to 35:1. NORD can often provide a two-stage reducer when most companies must provide three-stage units or resort to the use of a hypoid gear design. The same situation applies to three, four and higher gear stages. This allows NORD to provide superior value and performance in many conditions.

### Benefits

- Better value
- Higher efficiency
- Quieter operation
- Lower weight
- Longer life





## Oversized Output Shaft Bearings

NORD modular worm gear units are designed with oversized output bearings. Bearing sizes are significantly larger than required to absorb the internal forces within the gear unit. As a by-product of the larger bearings, the internal shaft diameters increase, resulting in increased shaft strength and durability as well as larger hollow-shaft bore capacities. Compared to competitive worm gear units, NORD'S intentional selection of oversized output bearings provides the following advantages:

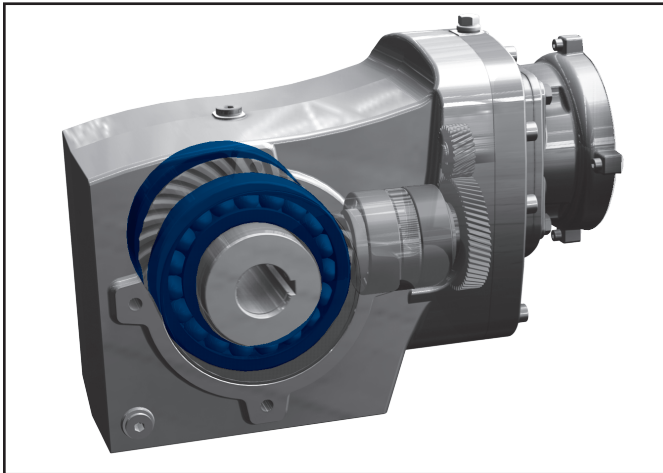

### Benefits

- Longer bearing life.
- Ability to support large overhung and thrust loads.
- Larger internal shaft diameters/Increased strength.
- Larger hollow bore capacities.

## Factory Oil Filled

All 92.1 & 93.1 Series Bevel units are filled at the factory with the proper quantity and type of lubrication. Oil fill before shipping prevents damage from dry start-ups.



### Benefits

- No need for filling on-site
- Ensures proper oil grade and fill level

## NORD High-Performance Motors & Options

NORD motors are designed to run cool for producing longer service life. Low rotor inertia and high starting torque allow peak performance in the most difficult applications for inverter and vector duty per NEMA MG 1-2006 Section 31.4.4.2 voltage spikes. Our motors are internationally accepted, conforming to North American NEMA MG 1 and international IEC electrical specifications. High performance options include brakes, encoders, and forced cooling fans.

## AUTOVENT™

The AUTOVENT™ helps prevent bearing & gear damage by behaving like a check valve to block the entry of foreign material & prevent contamination from dust particles, moisture and air-borne process chemicals. The breather opens at approximately 0.3-0.9 psi during operation and closes tightly as the gearbox cools. This is perfect for humid conditions & wash-down environments, helping to maintain proper oil cleanliness, while reducing foaming and oxidation.

### Benefits

- Cleaner gearbox oil
- Extended lubrication life
- Longer-lasting seals, gears, and bearings

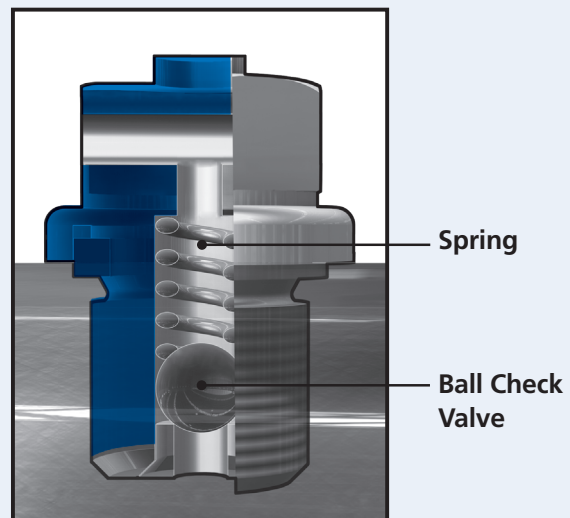

# Key Features



INTRODUCTION

## Premium Efficient Gearing

Providing up to 97% gear efficiency, NORD 2-stage helical-bevel gearmotors and reducers are an extension to NORD's complete line of energy saving products. Without a premium efficient gearbox, the efficiencies gained by the motor are often greatly reduced or lost because a less efficient gear drive is specified by the end-user or the equipment builder.

Combining NORD's premium efficient 92.1/93.1 helical-bevel gear units with NORD's premium efficient motors and AC variable frequency drives will provide opportunities for huge gains in system efficiency. For example, a conveyor used at a large order fulfillment center is designed to operate at maximum capacity, handling its highest volume at a conveyor speed of 300 feet per minute. Most of the year the conveyor needs to process only 50-60% of the normal package volume. In this case reducing the belt speeds down to 150-180 feet per minute, results in a direct energy savings of 50-60%; close control over conveyor belt speed is the key to reducing costs!

Standardizing on drive system packages that include NORD premium efficient motors, gearing and AC drives can also lead to considerable reduction in power system variants, reduced maintenance, the demand for less spare drive units, and reduce overall total cost of ownership. This is especially true on large systems such as those commonly found in warehouse material handling, postal and parcel systems, and airport baggage handling, and large bottling systems.

### Advantages:

- Reduced energy consumption.
- Opportunities for variant reduction.
- Reduced maintenance costs.
- Reduction in critical spare drive units.
- Reduced total cost of ownership.

## Compact Quadrilip™ Sealing System

The NORD 92.1/93.1 series helical-bevel gear units feature a compact QUADRILIP™ output shaft sealing system with four distinct seal barriers. A narrow axial, modular design, is accomplished by combining the inner seal directly with the spring-loaded, double-lip outer seal. The outer seal ring features a secondary exclusion lip to provide enhanced protection from external contaminants. The outer casing of the outer seal is a covered in smooth fluoroelastomer where the metal backing plate provides rigidity, while the elastomer facilitates easy fitting and ensures reliable sealing of the reducer housing bore. The primary single-lip inner seal ring is nitrile rubber providing the optimal oil sealing solution. A grease pack between the inner and outer seals provides lubrication and an additional protective barrier.

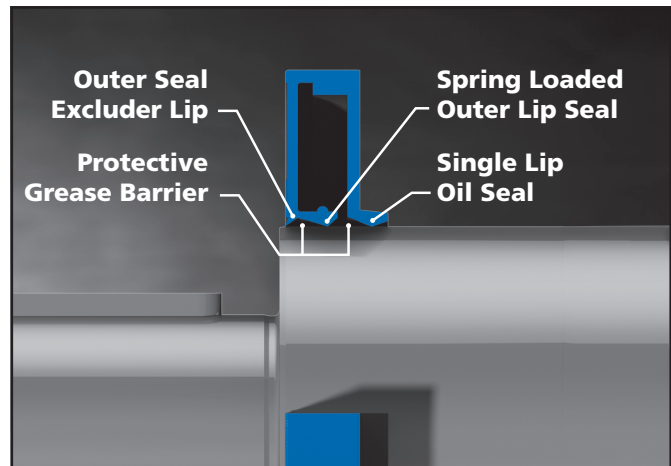

### Advantages:

- Four distinct seal barriers (QUADRILIP™).
- Compact / narrow axial design.
- Superior protection against leaks.
- Enhanced contamination protection.
- Long seal life.
- Increased reliability / reduced maintenance costs.



92.1 Bevel



93.1 Bevel

# 2 Stage Bevel Ordering Guide

<b>SK</b>	①	②	③	④	⑤
	Gear Unit	Shaft/Mounting	Shaft/Mounting Options	Reducer Options	Motor/Input
					see page 28
					see page 153

① Gear Unit	
92072.1	93072.1
92172.1	93172.1
92372.1	93372.1
92672.1	93672.1
92772.1	93772.1

② 92.1 Shaft/Mounting	
V - Universal Feet/B14 Face Flange/Solid Shaft	A - Universal Feet/B14 Face Flange/ Hollow Shaft
VF - Universal Feet/B5 Flange/Solid Shaft	AF - Universal Feet/B5 Flange/ Hollow Shaft
L - Universal Feet/B14 Face Flange/Double Solid Shaft	

② 93.1 Shaft/Mounting	
V - B14 Face Flange/Solid Shaft	A - B14 Face Flange/Hollow Shaft
VF - B5 Flange/ Solid Shaft	AF - B5 Flange/Hollow Shaft
L - B14 Face Flange/ Double Solid Shaft	AX - Tapped Feet/B14 Face Flange/Hollow Shaft
VX - Tapped Feet/B14 Face Flange/Solid Shaft	AXF - Tapped Feet/B5 Flange/Hollow Shaft
VXF - Tapped Feet/B5 Flange/Solid Shaft	
LX - Tapped Feet/B14 Face Flange/Double Solid Shaft	

③ Shaft/Mounting Options	
<input type="checkbox"/> Keyed Hollow Shaft  22	<input type="checkbox"/> D - Torque Arm  23
<input type="checkbox"/> SH - Shrink Disc & Cover  22	<input type="checkbox"/> SM -Stainless Steel Shaft  23
<input type="checkbox"/> MH - GRIPMAXX™  25	<input type="checkbox"/> SWV -Special Solid Shaft  23
<input type="checkbox"/> H - Hollow Shaft Cover  22	<input type="checkbox"/> SWA -Special Hollow Shaft  23
<input type="checkbox"/> B - Fixing Element Kit  23	<input type="checkbox"/> Worm Footplate Kit  21

④ Reducer Options	
<input type="checkbox"/> OSG - Oil Sight Glass  24	<input type="checkbox"/> LL - Long Term Storage  25
<input type="checkbox"/> MDP - Magnetic Drain Plug  25	<input type="checkbox"/> PR - Flange Pilot Removal  21
<input type="checkbox"/> ADP - Additional Drain Plug  25	<input type="checkbox"/> VI - Flouro-rubber Seals  24

⑤ Input Shaft	NEMA Adapter	IEC	Integral Motors	Integral Premium Efficient Motors	Integral Intermittent Duty (60 min) Motors
W	N56C N140TC N180TC N210TC N250TC	IEC 63 IEC 71 IEC 80 IEC 90 IEC 100 IEC 112 IEC 132 IEC 160	63S/4 - 0.16hp 63L/4 - 0.25hp 71S/4 - 0.33hp 71L/4 - 0.50hp 80S/4 - 0.75hp	80LP/4 - 1hp 90SP/4 - 1.5hp 90LP/4 - 2hp 100LP/4 - 3hp 112MP/4 - 5hp 132SP/4 - 7.5hp 132MP/4 - 10hp	80L/4 - 1hp 90S/4 - 1.5hp 90L/4 - 2hp 100L/4 - 3hp 100LA/4 - 5hp 112M/4 - 5.4hp 132S/4 - 7.5hp 132M/4 - 10hp
				Other Speeds Available	Other Speeds Available

## Product Specifications

**Ratio**  
 :1  
 see pages 65 - 82  
 — OR —  
**Output Speed**  
 rpm  
 see pages 65 - 82

**Mounting Position**

M1  
 M2  
 M3  
 M4  
 M5  
 M6  
 Special \_\_\_\_\_

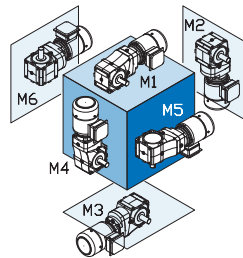

**Paint**

Standard Stainless Steel Paint  
 NSD+ (gray)  
 NSD+W (white)  
 NSD-X3 (gray)  
 NSD-X3W (white)  
 NSD-Tuph  
 Special \_\_\_\_\_

**Lubricant**

Standard  
 Synthetic  
 Food Grade  
 Other \_\_\_\_\_

<p><b>Solid Shaft Side</b> (if required)</p> <input type="radio"/> Shaft Side A <input type="radio"/> Shaft Side B <input type="radio"/> Shaft Side A&B see page 17	<p><b>Hollow Shaft Diameter</b> (if required)</p> <input type="text"/> see page 141	<p><b>B5 Flange Side</b> (if required)</p> <input type="radio"/> Flange Side A <input type="radio"/> Flange Side B <input type="radio"/> Flange Side A&B see page 17	<p><b>B5 Flange Diameter</b> (if required)</p> <input type="text"/>	<p><b>Torque Arm Side &amp; Location</b> (if required)</p> <input type="radio"/> Side A <input type="radio"/> Side B Location see page 17	<p><b>Shrink Disc /GRIPMAXX™ Side</b> (if required)</p> <input type="radio"/> Side A <input type="radio"/> Side B see page 17	<p><b>H66 Side</b> (if required)</p> <input type="radio"/> H66 Side A <input type="radio"/> H66 Side B see page 17
--	--	---	---	--	---	--

## Gearmotor Only Details

**Voltage & Frequency**

230/460V-60Hz (460V only ≥ 40 hp)  
 575V-60Hz  
 208V-60Hz  
 400V-50Hz  
 115/230V-60Hz, 1 ph.  
 Other \_\_\_\_\_

**Terminal Box Pos.**

TB1  
 TB2  
 TB3  
 TB4

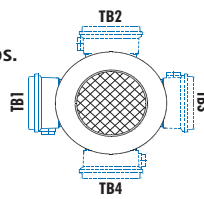

Mtg. Pos. M1 Shown

**Conduit Entry Loc.**

CE I \*  
 CE II  
 CE III \*  
 CE IV

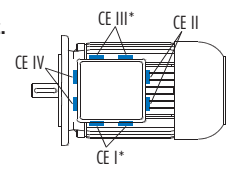

Mtg. Pos. M1 Shown

\* Brakemotor





# Motor Order Form



INTRODUCTION

SK	Frame	Size	Poles	Motor Options	Brake Size	Brake Options
	63 71 80 90 100 112 132	S SH SP M MH MP L LA LH LP	4 2 6 4-2 8-2 8-4 12-2 Other	<b>Electrical Motor Options</b> <input type="checkbox"/> H - Energy Efficient Motor <input type="checkbox"/> P - Premium Efficient Motor <input type="checkbox"/> TW - Thermostat <input type="checkbox"/> TF - Thermistor <input type="checkbox"/> SH - Space Heater (select voltage) ○ 110 Volt   ○ 230 Volt   ○ 460 Volt <input type="checkbox"/> ISO H - Class H insulation <input type="checkbox"/> WU - High Resistance Rotor <input type="checkbox"/> 4-2 - 2-Speed, 4/2 Pole, 1800/3600rpm <input type="checkbox"/> 8-2 - 2-Speed, 8/2 Pole, 900/3600rpm <input type="checkbox"/> ECR - Single Phase Motor  <b>Environmental Options</b> <input type="checkbox"/> NSD+ - Nord Severe Duty Paint <input type="checkbox"/> NSDx3 - Nord Extreme Duty Paint <input type="checkbox"/> RD - Canopy Drip Cover <input type="checkbox"/> RDD - Double Fan Cover <input type="checkbox"/> KB - Condensation Drain Holes (plugged) <input type="checkbox"/> KBO - Condensation Drain Holes (open) <input type="checkbox"/> IP66 - IP66 Enclosure Protection <input type="checkbox"/> KKV - Terminal Box Sealed with Resin <input type="checkbox"/> AICM - Additional Insulation <input type="checkbox"/> EP - Epoxy Dipped Windings  <b>AC Vector Drive Related Options</b> <input type="checkbox"/> F - Blower Fan (200-575V 1 & 3 Phase) <input type="checkbox"/> FC - Blower Cooling Fan (115V, 1 Phase) <input type="checkbox"/> IG__ - Incremental Encoder <input type="checkbox"/> IG_P - Incremental Encoder with Plug <input type="checkbox"/> AG - Absolute Encoder <input type="checkbox"/> MG - Magnetic Encoder  <b>Additional Motor Options</b> <input type="checkbox"/> OL - Totally Enclosed Non-Ventilated (TENV) <input type="checkbox"/> OL/H - (TENV) Without Fan Cover <input type="checkbox"/> WE - Second Shaft Extension (Fan Side) <input type="checkbox"/> HR - Hand Wheel <input type="checkbox"/> Z - High Inertia Cast Iron Fan <input type="checkbox"/> RLS - Motor Backstop (rotation viewing fan) ○ Clockwise   ○ Counter-Clockwise <input type="checkbox"/> EKK - Small Terminal Box (not UL approved) <input type="checkbox"/> MS - Quick Power Plug Connector	<b>BRE 5</b> <b>BRE 10</b> <b>BRE 20</b> <b>BRE 40</b> <b>BRE 60</b>	<input type="checkbox"/> HL - Hand Release Lever <input type="checkbox"/> FHL - Locking Hand Release Lever <input type="checkbox"/> HLH - Hand Release Lever with Hole <input type="checkbox"/> RG - Corrosion Protected Brake <input type="checkbox"/> SR - Dust and Corrosion Protected Brake <input type="checkbox"/> ADJ__Nm - Adjust Brake Torque <input type="checkbox"/> BIP66 - IP66 Brake Enclosure <input type="checkbox"/> MIK - Micro-switch <input type="checkbox"/> BSH - Brake Heating/Bifilar Coil <input type="checkbox"/> NRB1 - Quiet Brake Release <input type="checkbox"/> NRB2 - Quiet Brake Motor Operation <input type="checkbox"/> FBR - Brass Foil <input type="checkbox"/> DBR - Double Brake <input type="checkbox"/> G..P - High Performance Rectifier <input type="checkbox"/> G..V - Sealed Rectifier <input type="checkbox"/> IR - Current Sensing Relay
	<b>Paint</b> <input type="checkbox"/> Unpainted Aluminum Alloy <input type="checkbox"/> Stainless Steel Paint <input type="checkbox"/> NSD+ (gray) <input type="checkbox"/> NSD+W (white) <input type="checkbox"/> NSD-X3 (gray) <input type="checkbox"/> NSD-X3W (white) <input type="checkbox"/> Special _____			<b>Rectifier Selection</b> <b>Rectifier Wiring</b> <input type="checkbox"/> Across the line (from motor terminal box) <input type="checkbox"/> Separate power source (frequency AC vector drive, soft starter)		
				<b>Brake Supply Voltage</b> <input type="checkbox"/> 24 VDC <input type="checkbox"/> 115 VAC <input type="checkbox"/> 200 VAC <input type="checkbox"/> 230 VAC <input type="checkbox"/> 400 VAC <input type="checkbox"/> 460 VAC <input type="checkbox"/> 500 VAC <input type="checkbox"/> 575 VAC <input type="checkbox"/> Other _____	<b>Braking Method*</b> <input type="checkbox"/> Method 10 <input type="checkbox"/> Method 15 <input type="checkbox"/> Method 20 <input type="checkbox"/> Method 25 <input type="checkbox"/> Method 30 <input type="checkbox"/> Method 35 <input type="checkbox"/> Method 40 <input type="checkbox"/> Method 45 <input type="checkbox"/> Method 50 <input type="checkbox"/> Method 55	
				* More info on page 205		
				<b>Hand Release Position</b> <input type="checkbox"/> HL1 <input type="checkbox"/> HL2 <input type="checkbox"/> HL3 <input type="checkbox"/> HL4		

### Mounting

- Integral to gearbox
- NEMA C-Face
- NEMA T-Footed
- IEC B5 Mount
- IEC B14 Mount
- IEC B3-Footed

### Voltage & Frequency

- 230/460V-60Hz
- 575V-60Hz
- 208V-60Hz
- 400V-50Hz
- 115/230V, 60Hz-1-ph.
- Other

### Terminal Box Pos.

- TB1
- TB2
- TB3
- TB4

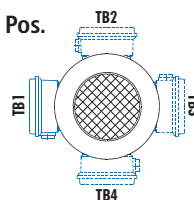

Mtg. Pos. M1 Shown

### Conduit Entry Loc.

- CE I \*
- CE II
- CE III \*
- CE IV

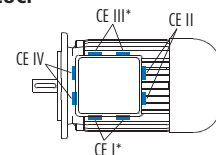

\*Brakemotor

Mtg. Pos. M1 Shown



## Gearbox Selection

A number of factors are considered when selecting a gear unit, including gearbox rating, service factor, speed and speed variation, horsepower, thermal capacity, ratio, physical size, ambient conditions and cost. Below are some guideline steps to help aid in the gear unit selection.

1. Determine the speed and/or gear ratio
2. Determine the required power or torque
3. Determine Service Factor
4. Select the basic gearbox type and input
5. Determine the required mounting position
6. Select options
7. Checks – overhung load, thrust load, NEMA motor weight, thermal considerations, and other application considerations

### 1. Speed and Gear Ratio

The first step in selecting a gear unit is determining the final output speed or speeds you need. This speed is normally described in revolutions per minute (rpm). This output speed or speeds is determined by the input speed to the gear unit divided by its gear ratio. Their relationship is described by the following formulas.

$$i \text{ (gear ratio)} = \frac{\text{Input speed [rpm]}}{\text{Output speed [rpm]}}$$

$$\text{Output speed [rpm]} = \frac{\text{Input speed [rpm]}}{i \text{ (gear ratio)}}$$

To specify a gear unit, you can identify either gear ratio needed or the output speed (rpm) if the input speed is known.

### 2. Power and Torque

The second step for selecting a gear unit is the required power or torque needed to power the load. Torque in this catalog is normally expressed in pound-inches [lb-in].

$$\text{Power [hp]} = \frac{\text{Torque [lb-in]} \times \text{speed [rpm]}}{63025}$$

$$\text{Torque [lb-in]} = \frac{\text{Power [hp]} \times 63025}{\text{speed [rpm]}}$$

For a proper selection you must ensure that the motor or other prime mover can produce enough torque or power and that the gear unit has adequate torque or power capacity.

To specify a gear unit you can identify either torque or power.

### 3. Service Factor or Service Class

In addition to power or torque, service factor must also be considered. A service factor is essentially the ratio of extra capacity in a gear unit compared to the power or torque that is needed to run that application. The goal of selecting a gear unit with extra capacity (service factor) is to provide adequate service life in operation.

One reason to apply a larger service factor is if a unit operates more hours per day. If a unit runs 24 hours per day it should normally have a higher service factor than a unit that runs 8 hours per day if you expect the same calendar life.

A second reason for applying a larger service factor is to cope with a more difficult application. Even if it takes the same power and speed to operate a rock crusher as a fan, the rock crusher needs a stronger gearbox (higher service factor) to give the same calendar operating life as the gear unit powering the fan.

The real question is how to determine the proper service factor for a gear unit in an application. Following are four possible methods.

#### Customer or User Specification

Many customers will have their own service factor guidelines or specifications.

#### AGMA Service Factoring

American Gear Manufacturers Association (AGMA) publishes lists of recommended service factors for different applications. These service factor recommendations have been determined from the experience of many gear manufactures and are in AGMA standard 6010. See page 51 for additional detail.

#### AGMA Service Classes

American Gear Manufacturers Association (AGMA) has another method for selecting gear units service factors. AGMA standard 6009 lists many applications by a service class (I, II, III) with class I being the simplest applications and class III being the hardest. These application service classes are associated with a range of service factors by the following table.

AGMA Service Class	Service Factor
I	1.00 to 1.39
II	1.40 to 1.99
III	2.00 and above

In the gearmotors selection table each unit is also classified by an AGMA service class. See page 51 for additional detail.



## NORD Mass Acceleration Service Factoring

NORD often uses a calculation based system to properly assign a service factor. This system considers hours of operation per day, the severity of the application and the number of times the equipment is cycled. See page 51 for additional detail.

### 4. Gearbox Type & Input

2-Stage Helical-bevel gear drives are available in the following mechanical configurations including:

- Foot mount
- Flange mount
- Foot mount with flange

NORD's modular design allows for a number of different input configurations including:

- Integral motor
- NEMA-C and IEC motor adapter
- Solid input shaft

### 5. Mounting Position

The gearbox mounting position is an important and often overlooked specification. The mounting position determines how much oil the gear reducer requires, in addition to determining the position of the oil drain, oil fill and vent on the gear drive. NORD offers six basic mounting positions. If your application requires a variation from the six basic mounting positions, please contact NORD.

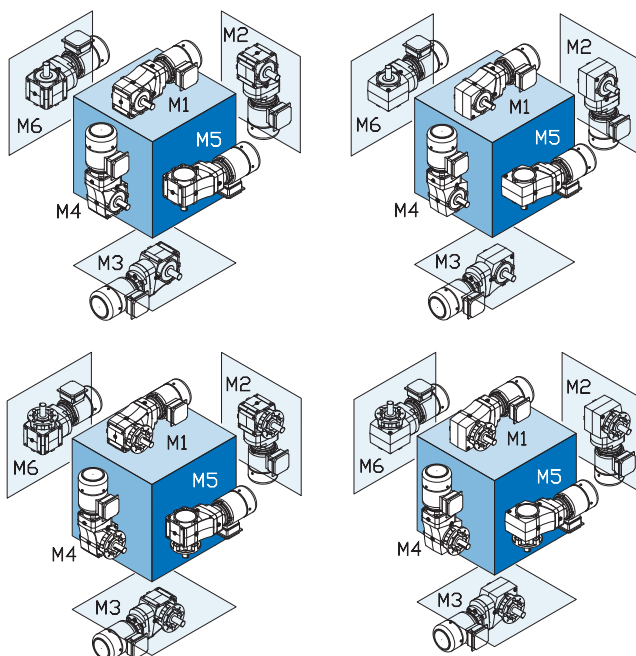

### 6. Options

NORD offers a number of mechanical, protective, paint and lubrication options for gear reducers and motors. Please see page 20 for gear unit options and refer to the motor section for motor options.

### 7. Checks

#### Overhung Load

An overhung or radial load exists when a force is applied at right-angles to a shaft beyond the shaft's outermost bearing. Pulleys, sheaves and sprockets will cause an overhung load when used as a power take-off. The amount of overhung load will vary, depending on the type of power take-off used and where it is located on the shaft.

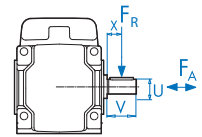

Overhung load  $[F_R]$  can be found in the gearmotor rating tables and input shaft overhung load ratings  $[F_{R1}]$  can be found on pages 40 - 44. Overhung load capacities should not exceed the values in the table to ensure long bearing life.

To calculate overhung load see page 40.

#### Thrust Loads (Axial)

Loads that are directed towards or away from the gearbox along the axis of the shaft are called thrust or axial loads. Output shaft thrust capacity  $[F_A]$  can be found in the gearmotor rating tables. Input shaft capacity  $[F_{A1}]$  can be found on pages 44. Thrust load capacities should not exceed the values listed in the tables to ensure long bearing life. Contact NORD for combination loads or a more exact examination of the application.

#### NEMA C-face Motor Weight Limits



When mounting a motor to a NORD NEMA C-face motor adapter it is important to consider the motor's weight. Following is a table that includes the maximum motor weight the NEMA adapter can support. If the motor exceeds the listed weight it must be externally supported. When a C-face mounted motor is externally supported care must be taken to ensure that the support system does not impose additional pre-loads on the NEMA motor adapter.

#### NEMA Weights

Motor FRAME	56C	143TC	145TC	182TC
Max Weight [lb]	66	88	110	130
Motor FRAME	184TC	210TC		
Max Weight [lb]	175	220		





**GENERAL WARNINGS & CAUTIONS**

Applications with risk of personal injury should be reviewed together with NORD. Examples of these are hoist, lifts or other applications where people may be at risk.

### NEMA and IEC Adapters

NEMA/IEC adapter have additional shaft coupling and additional bearing seats compared to integral motors so there are higher no-load losses with NEMA or IEC adapters. We recommend mounting the motor directly, since it offers both technical and cost advantages.

NEMA and IEC adapters used in hoist, lifts and other applications with danger of personal injury should be reviewed together with NORD.

### NEMA C-Face Adapter Capacity

The NEMA adapters are designed to handle the torques produced by the standard NEMA power assignment at 4-pole (1800 rpm) motor speeds. If a larger motor power is used than the power below, NORD should be consulted. Also if a NEMA adapter is being used for other than an AC induction motor NORD should be consulted.

Adapter	Max Power [hp]
56C	1
140TC	2
180TC	5
210TC	10

### External Installation, Tropical Use

Gearboxes installed outside, in damp rooms, or used in the tropics may require special seals and anti-corrosion options. Please contact NORD for application assistance.

### Special conditions

If special environmental or other conditions exist in transit, storage or operation these need to be considered in the unit selection. Special conditions may include (but are not limited to):

- Exposure to aggressive corrosive materials (contaminated air, gasses, acids, bases, salts, etc.)
- Very high relative humidity
- Direct contact between the motor and liquid
- Material build-up on the gear unit or motor (dirt, dust, sand, etc.)
- High atmospheric pressure
- Radiation
- Extreme temperatures, high, low or large temperature changes
- High vibration, acceleration, shocks or impacts
- Other abnormal conditions

### Gear Reducer Ratings

The permissible continuous power limit of gear reducers is limited by both the mechanical rating and the thermal rating. The mechanical rating depends upon the material strength of the gear reducer's gears, bearings, housing, shafts, etc. The mechanical input power limit to the reducer is also a function of the mechanical power rating divided by the relevant reducer service factor.

The thermal rating or thermal limit depends upon the amount heat generated within the reducer and is influenced by a variety of factors including:

- Churning or splashing losses in the lubricant which depend upon reducer type, ratio, input style, mounting position or oil fill-level, and the circumferential travel velocities of the gear wheels.
- The actual speed and load conditions. These factors determine load-dependent losses in the gear areas and frictional losses in the gear, bearing & seal areas.
- Ambient Conditions:
  - Ambient Temperature.
  - Amount of free air circulation around the drive.
  - Possible near-by heat sources.
  - Heat dissipation or the ability of the reducer to transfer heat through the housing, shafts, and the mating sub-structure or mounting surface.

### Storage Before Installation

The gear units and motors should be stored in a dry area before they are to be installed. Special measures are required for longer storage. Please request long term storage instructions from NORD Gear or see page 25.



## Observing the Reducer's Thermal Limit

### When to Contact NORD

Through computer program analysis NORD can evaluate application conditions and the impact they have on a reducer's thermal capacity.

When applying case sizes SK92672.1/93672.1 and larger, please consult NORD if any two or more of the following conditions apply:

- Gear ratio,  $i_{total} \leq 48:1$
- Input speed,  $n_1 > 1800$
- Vertical positioning (mounting position M2 or M4)
- Input configuration: NEMAC-face, IEC, servo adapter or solid-shaft input (Type-W)
- An elevated ambient temperature  $\geq 86^\circ \text{F}$  ( $30^\circ \text{C}$ )

### Dangers of Reducer Overheating

The following problems may result when the reducer's thermal capacity or maximum oil sump temperatures are exceeded:

- Lubrication oxidation, breakdown & deterioration.
- A decrease in lubrication viscosity & film thickness.
- Loss of critical bearing and gear clearances required for proper lubrication.
- Increased contact pressures and increased operating temperatures in the critical load zones of the gearing and bearings.
- An increased possibility for metal-to-metal contact and premature component wear.
- A significant reduction in the lubricant's ability to prevent scuffing, pitting, and in extreme cases galling or welding.

## Maximum Oil Sump Temperature Limit

To prevent reducer overheating, the reducer's maximum oil sump temperature limit must not be exceeded for prolonged periods of operation (up to 3 hours continuous operation, depending upon reducer size).

Oil Type	Maximum Oil Temperature Limit	
	NORD	AGMA 9005-D94
Mineral	80-85 °C (176-185 °F)	95 °C (203 °F)
Synthetic	105 °C (220 °F)	107 °C (225 °F)

**IMPORTANT NOTE**

*Use caution when specifying gear reducers for high temperature service.* If there is concern about exceeding the allowable safe operating temperatures, please consult NORD to discuss alternatives.

### Measures to Expand the Application Range

There are a variety of measures that may be taken in order to protect against thermal overload and expand the application range of the gear reducer. Common examples include the following:

- Recommending a change in lubrication viscosity and/or a specific synthetic lubricant type.
- Applying high-temperature seals.
- Increasing air flow around the gear unit.
- Shielding or protecting the reducer from high heat sources.
- Considering an integral motor instead of the bolt-on input assembly covers. In many cases the motor fan will substantially increase air-flow around the gear unit.



**Contact:** \_\_\_\_\_ **Company:** \_\_\_\_\_  
**Telephone:** \_\_\_\_\_ **Email:** \_\_\_\_\_  
**Fax:** \_\_\_\_\_ **Date:** \_\_\_\_\_  
**Project Name:** \_\_\_\_\_ **Application:** \_\_\_\_\_  
**Qty:** \_\_\_\_\_ **Type:** **SK** \_\_\_\_\_

### Gearbox Parameters

**Unit**

Gearmotor       Gearbox with Motor Adapter  
 Gearbox with Solid Input Shaft

**Mounting Position**

M1       M4  
 M2       M5  
 M3       M6  
 Special \_\_\_\_\_

**Lubricant**

Standard  
 Synthetic  
 Food Grade  
 Other \_\_\_\_\_

**Flange**

None  
 B14 (Z)  
 B5 (F) Outside Diameter \_\_\_\_\_ [mm]

Ratio \_\_\_\_\_ : 1 or Output Speed \_\_\_\_\_ [rpm]

Output Torque \_\_\_\_\_ [lb-in] or Power \_\_\_\_\_ [hp]

Minimum Service Factor [ $f_b$ ] \_\_\_\_\_ [lb]

Radial Load at Output Shaft [ $F_o$ ] \_\_\_\_\_ [lb]

Axial Load at Output Shaft [ $F_A$ ] \_\_\_\_\_ [lb]

Distance from Shaft Shoulder [x] \_\_\_\_\_ [in]

Minimum Required Bearing Lifetime [Lh10] \_\_\_\_\_ [hours]

**Bearing Type**

Standard  
 AL - Axial/Thrust

### Environmental Parameters

Ambient Temperature Range \_\_\_\_\_ °F to \_\_\_\_\_ °F

**Location of Unit**

Indoor  
 Outdoor  
 Severe Environment

**Paint**

No Paint  
 Stainless Steel Paint  
 NSD+ (gray)  
 NSD+W (white)  
 NSD-X3 (gray)  
 NSD-X3W (white)  
 Casting Primed  
 Special \_\_\_\_\_

### Motor Parameters

Power \_\_\_\_\_ [hp]

**Voltage & Frequency**

230/460V-60Hz  
 575V-60Hz  
 208V-60Hz  
 400V-50Hz  
 115/230V-60Hz, 1 ph.  
 Other \_\_\_\_\_

**Enclosure**

IP55 (Standard)  
 IP66

**Insulation Class**

F (Standard)  
 H

**Duty**

S-1 Continuous Operation  
 Periodic/Short Time Operation

Cycles Per Hour \_\_\_\_\_ cycles/hour

**Terminal Box Position**

TB1  
 TB2  
 TB3  
 TB4

**Conduit Entry Location**

CE I \*  
 CE II  
 CE III \*  
 CE IV  
 \* Brakemotor

### Brake Parameters

**Brake**

No Brake (cont. to next section)  
 Holding Brake/Emergency Brake  
 Working Brake

**Brake Supply**

Power from motor term. block  
 Separate Power Source

Brake AC Supply \_\_\_\_\_ [Volts]

Brake Torque \_\_\_\_\_ [Nm]

**Brake Release**

Standard  
 Fast

**Brake Stopping**

Standard  
 Fast  
 Very Fast

### Frequency Inverter Parameters

**Frequency Inverter**

No Frequency Inverter  
 Customer Supplied Inverter  
 NORD Panel Mounted Frequency Inverter  
 NORD Motor Mounted Frequency Inverter

Line Voltage: \_\_\_\_\_ [Volts]      Frequency \_\_\_\_\_ [Hz]

Operating Frequency Range: \_\_\_\_\_ [Hz] to \_\_\_\_\_ [Hz]

**How is the Inverter Controlled?**

PC  
 Operator Control  
 Other

**Bus System?**

None       InterBus  
 Profibus       CANopen  
 CANBus       RS232  
 AS Interface

**Are You Using an Encoder?**

No  
 Yes →  Position Feedback  
     Speed Control



## Mounting Positions

The reducer mounting position determines the approximate oil fill level and the appropriate vent location. In some cases the mounting position may dictate possible variation in final reducer assembly. If considering any mounting positions that are not shown as catalog-standard options, it is critical that the customer consult with NORD prior to ordering.

### New Mounting Position System

NORD is in the process of incorporating a new mounting position systems. Historically the NORD mounting position system was based on international motor standards. NORD is changing in an effort to simplify the system. The new system is based on the six sides of a cube. Below is a cross reference between the old and new mounting position codes.

Mounting Position Cross Reference Table

New	M1	M2	M3	M4	M5	M6
Old	B3, B5	V3, V6	B8, B5I	V1, V5	B5II, B6	B7, B5III

### 92.1/93.1 Series Bevel

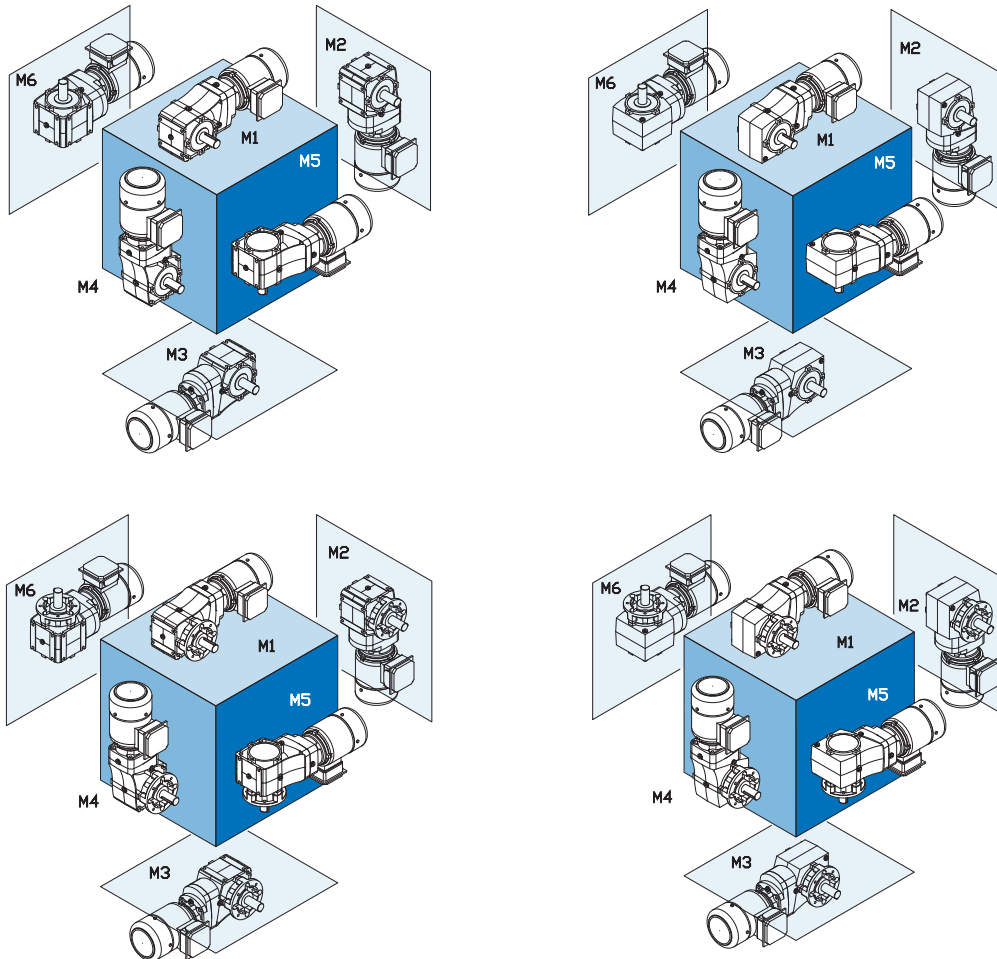





## Mounting Configuration

NORD provides gearmotors, speed reducers and motors that can be configured very differently to suit customer needs. It is beneficial while ordering that the drive be specified exactly the way you want it delivered.

### Mounting Positions

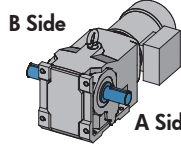
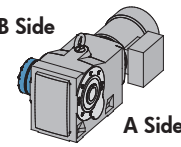
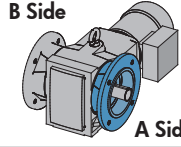
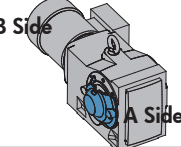
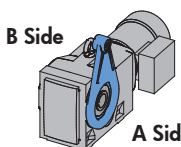
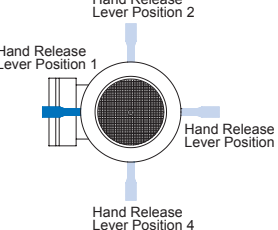
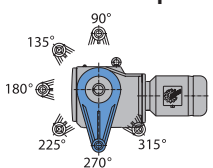
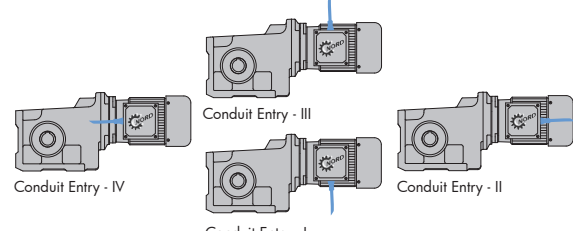
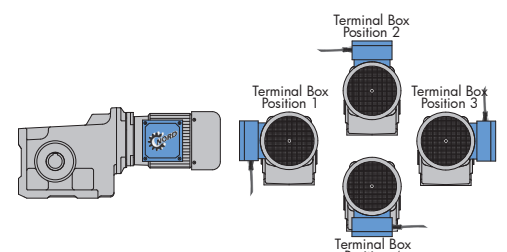
<b>Basic mounting</b>	
<input type="radio"/> M1	<input type="radio"/> M2 <input type="radio"/> M3 <input type="radio"/> M4 <input type="radio"/> M5 <input type="radio"/> M6
<b>Right-angle with solid shaft</b>	<b>Right-angle with shrink disc</b>
 <ul style="list-style-type: none"> <li><input type="radio"/> Shaft Side A</li> <li><input type="radio"/> Shaft Side B</li> <li><input type="radio"/> Shaft Side A+B</li> </ul>	 <ul style="list-style-type: none"> <li><input type="radio"/> Shrink Disc Side A</li> <li><input type="radio"/> Shrink Disc Side B</li> </ul>
<b>Right-angle flange mount units</b>	<b>Right-angle with hollow shaft cover</b>
 <ul style="list-style-type: none"> <li><input type="radio"/> Flange Side A</li> <li><input type="radio"/> Flange Side B</li> <li><input type="radio"/> Flange Side A+B</li> </ul>	 <ul style="list-style-type: none"> <li><input type="radio"/> Hollow Shaft Cover Side A</li> <li><input type="radio"/> Hollow Shaft Cover Side B</li> </ul>
<b>Right-angle with torque arm</b>	<b>Brake motor with hand release lever</b>
 <ul style="list-style-type: none"> <li><input type="radio"/> Torque Arm Side A</li> <li><input type="radio"/> Torque Arm Side B</li> </ul>	 <ul style="list-style-type: none"> <li><input type="radio"/> Hand Release Lever Pos. 1</li> <li><input type="radio"/> Hand Release Lever Pos. 2</li> <li><input type="radio"/> Hand Release Lever Pos. 3</li> <li><input type="radio"/> Hand Release Lever Pos. 4</li> </ul>
<b>Shaft mount torque arm orientation</b>  <p>Orientation _____</p>	<b>Conduit entry location</b>
<input type="radio"/> 92.1/93.1Bevel <input type="radio"/> 90° - 315°, Every 45°	 <ul style="list-style-type: none"> <li><input type="radio"/> Conduit Entry Location I*</li> <li><input type="radio"/> Conduit Entry Location II</li> <li><input type="radio"/> Conduit Entry Location III*</li> <li><input type="radio"/> Conduit Entry Location IV</li> </ul> <p>* Denotes Brakemotor</p>
<b>Terminal box location</b>	
 <ul style="list-style-type: none"> <li><input type="radio"/> Terminal Box Position 1</li> <li><input type="radio"/> Terminal Box Position 2</li> <li><input type="radio"/> Terminal Box Position 3</li> <li><input type="radio"/> Terminal Box Position 4</li> </ul>	



### NEMA & IEC MOTOR ADAPTERS 28

For attaching standard motors  
Contains:

- Adapter flange
- Coupling
- Nuts and bolts

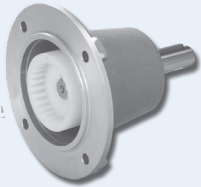

### SOLID INPUT SHAFT (W) 28

Fits all size gearboxes  
Lifetime lubricant  
Sealed unit

Kit contains:

- Pre-assembled unit
- Bolts

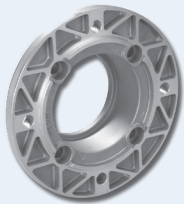

### B5 OUTPUT FLANGE (F) 21

Multiple flanges available for each size gearbox. Flange pilots are centered in seal bore.

Kit contains:

- Die cast flange
- Bolts



### TORQUE ARM (D) 23

For shaft mounting  
Rubber shock absorber installed in attachment end

Kit contains:

- Torque arm
- Bolts

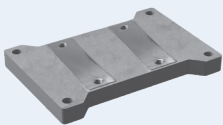

### FOOT PLATE ??

Mounts to the bottom of the 2-Stage Bevel to provide drop-in flexibility for many North American worm boxes

Kit contains:

- Foot Plate
- Bolts

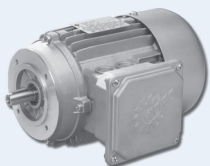

### NORD C-FACE MOTORS & BRAKEMOTORS 145

3 phase, 230/460, 60 Hertz

3 phase, 575V, 60 Hertz

Options Include:

- |                            |                         |
|----------------------------|-------------------------|
| • Power off brake          | • Encoders              |
| • Numerous brake options   | • Space heater          |
| • Thermistor temp. sensors | • Canopy drip covers    |
| • Thermostat temp. sensors | • Encapsulated windings |
| • Blower fan               | • End bell drain holes  |

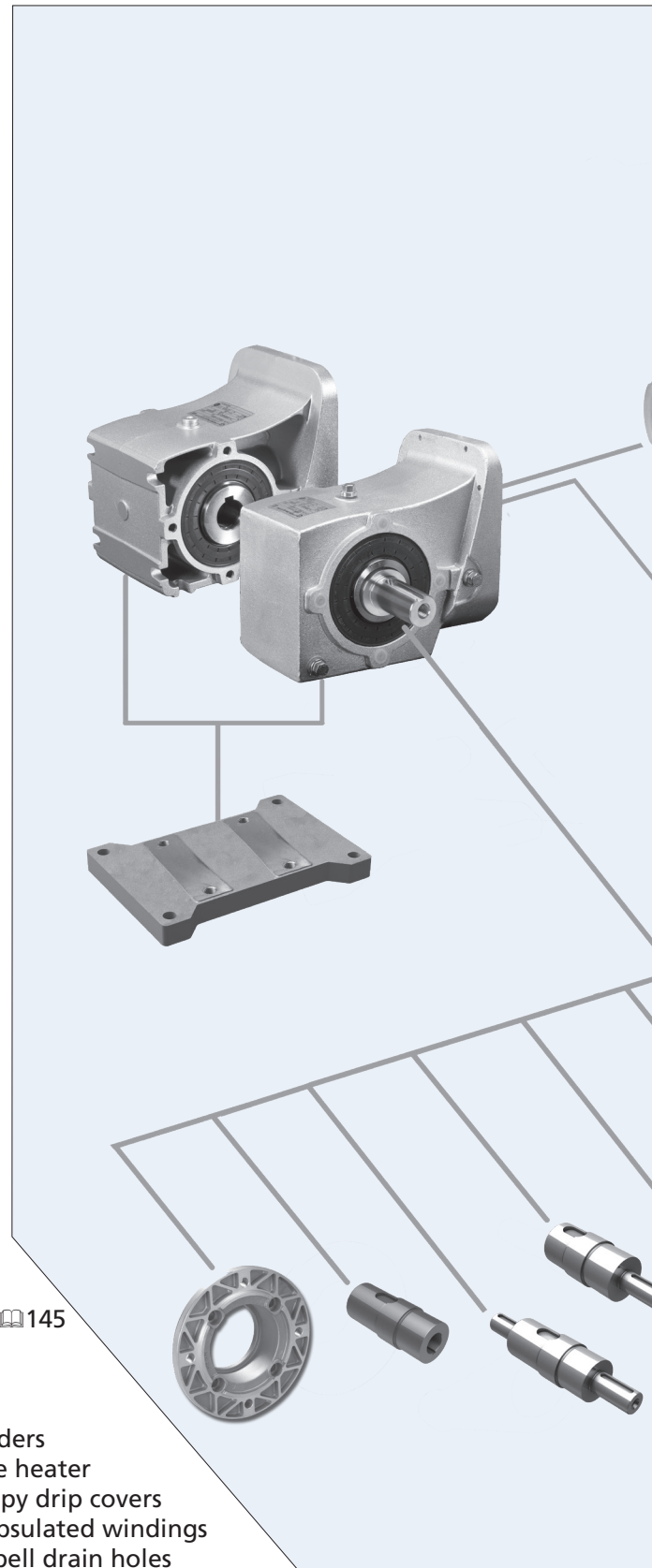

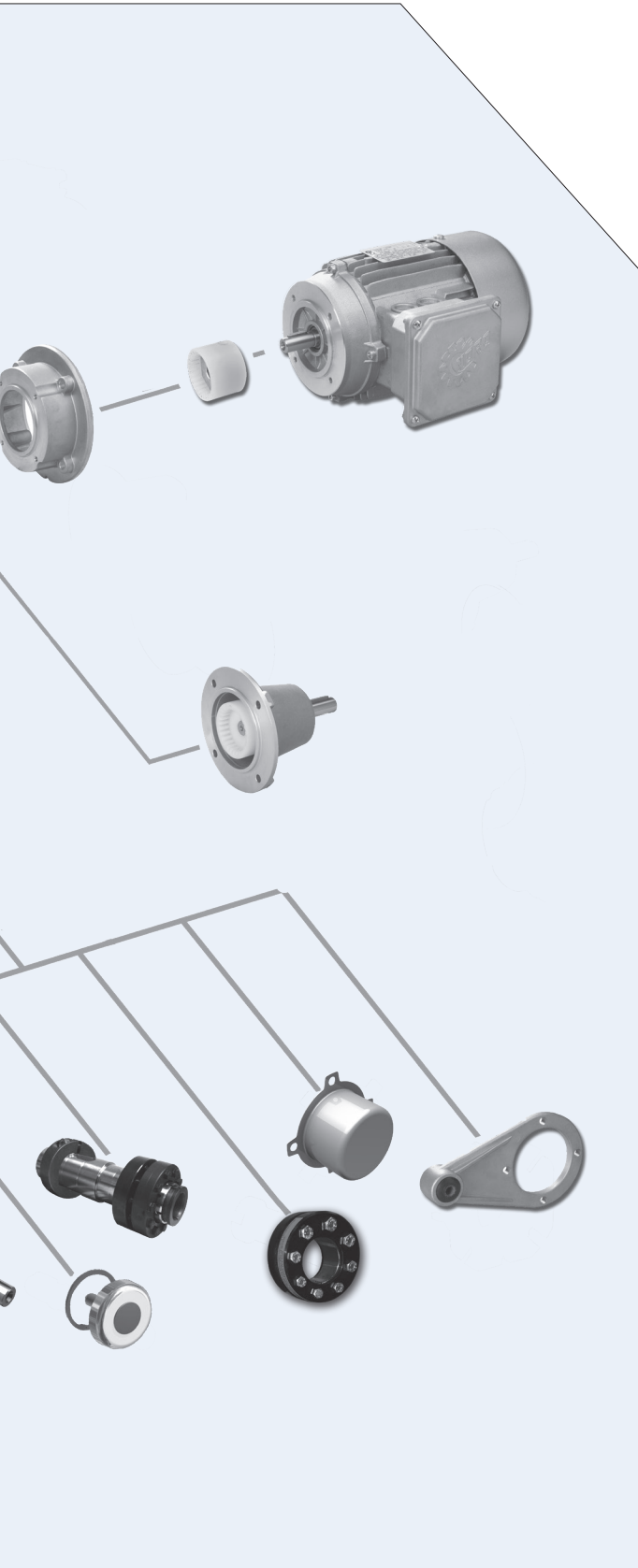

**SOLID SHAFT (V) (L)** 22

Inch dimensions with standard keys.  
Optional double solid shaft and metric shafts also available.

- Shaft
  - Keys
  - External snap ring
- Options:
- Double solid shaft

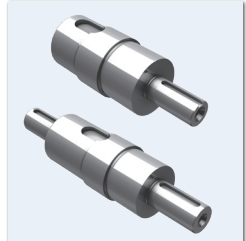

**SHAFT PROTECTION COVER (H)** 22

Seals shaft end Safety protection from rotating shaft

- Kit contains:
- Cover
  - Bolts

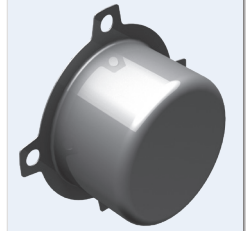

**SHRINK DISC & COVER (SH)** 22

Creates a keyless, mechanical interference fit for high cycle and reversing loads by “shrinking it onto the customer shaft. Install on either side

- Kit contains:
- Shrink Disc
  - Bolts
  - Shaft Protection Cover (H)



**GRIPMAXX™ (M)** 23

Hollow shaft bushing for keyless interchange in order to mount NORD hollow shaft reducers onto a large range of driven machine shaft sizes.

- GRPMAXX™ Bushings
- Shrink Disc
- Clamp Collar
- Shaft Protection Cover



**FIXING KIT (B)** 23

The Fixing Kit secures the customer shaft in an axial direction by using a tapped hole in the end of the mating male shaft.

- Fixing kit
- Retaining Washer
- Bore Plug
- Hardware

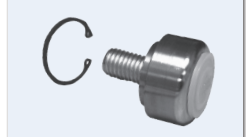



## 2-Stage Bevel Gearbox Options

Abbreviation	Description	Page
Blank	<ul style="list-style-type: none"> <li>• 92.1 Series Universal Housing (foot mount &amp; B14 flange) or</li> <li>• 93.1 Series Standard Housing (no tapped holes &amp; B14 flange)</li> </ul>	21
A	Keyed Hollow	22
ADP	Additional drain plug	25
AF	Keyed Hollow Shaft with B5 Flange	22 (A) & 21 (F)
B	Fixing Kit	23
D	Torque Arm	23
DR	AUTOVENT™	24
F	B5 flange	21
FKM	Fluoro-rubber seals	24
FV	Filtered Vent	24
H	Hollow Shaft Cover	22
LL	Long term storage	25
L	Double Solid Output Shaft	22
M	GRIPMAXX™ Hollow Shaft Bushing Kit	23
MDP	Magnetic drain plug	25
NSD <sup>tuph</sup>	NSD tuph sealed surface conversion	27
OSG	Oil sight glass	24
OV	Open vent	24
PR	B5 flange pilot removal	21
SH	Shrink Disc and Cover	22
SM	Stainless steel output shaft	23
SWV	Special Solid Shaft	23
SWA	Special Hollow Shaft	23
V	Solid Output Shaft	22
VF	Solid Output Shaft with B5 Flange	22 (V) & 21 (F)
X	93.1 Series Housing with Tapped Foot Holes	21
none	Industry Standard Worm Replacement Footplate	21
none	Special Drain Plugs	25
none	Paint coatings	26





## Mounting

A number of different mounting arrangements are offered with the 2-stage helical bevel units:

- Foot Mounting
  - 92.1 Series - slotted foot holes are standard.
  - 93.1 Series - tapped foot holes are optional.
- B14 Mounting flange (Standard on all units)
- B5 Mounting flange (F)
- Torque arm for shaft mounting (D)
- Footplate Kit (Blank) - option to retrofit and replace industry standard worm units.

### Foot Mounted (Blank or X)

Foot or base mounting is the most common method of reducer mounting. The speed reducer is secured in place with bolts or studs to a mounting base.

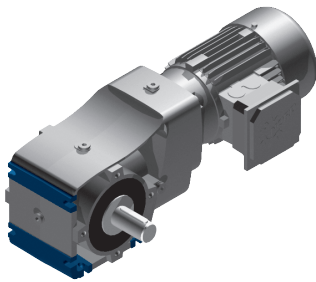

92.1 Series  
with slotted foot holes

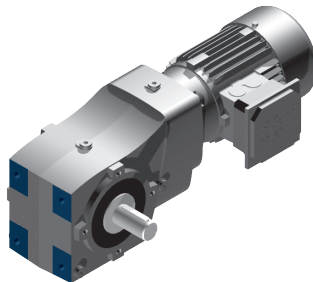

93.1 Series  
with optional tapped  
foot holes

### Industry Standard Worm Footplate

This footplate consists of both threaded holes and through holes machined into a mounting plate in order to mount to the 92.1 or 93.1 reducer housing. It is used in order to replace industry standard mounting patterns of helical worm gear units.

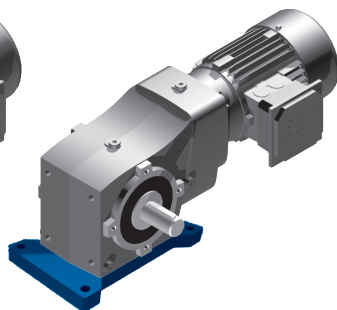
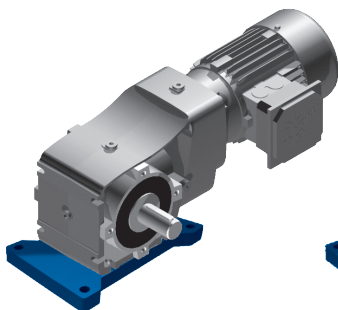

### B14 Flange (Standard on all units)

The B14 flange consists of threaded holes and a centering pilot machined into the reducer housing. It is commonly used to secure the reducer to the machine base or to mount one of many bolt on components such as a B5 flange, torque arm or shaft cover. The B14 flange uses standard metric dimensions and is a standard feature on both the 92.1 & 93.1 series units.

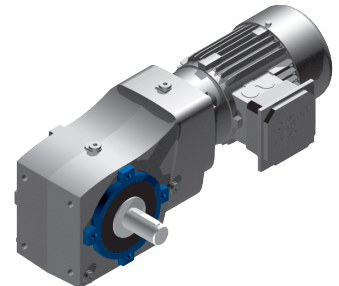
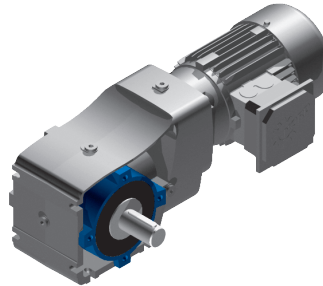

### B5 Flange (F)

A B5 flange provides a simple, large diameter mounting flange with clearance holes and a centering pilot to firmly secure the speed reducer to the application. The B5 flange utilizes standard metric dimensions. 92.1/93.1 Series bevel reducers offer a number of B5 flange diameters.

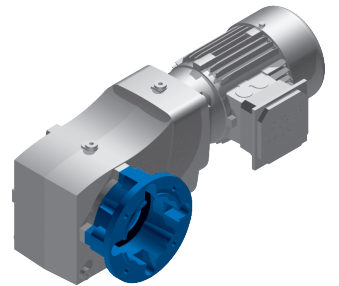
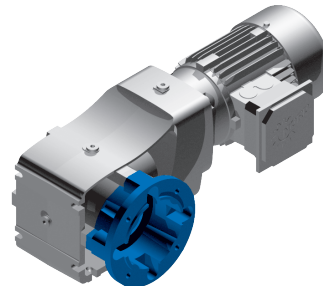

### B5 Flange Pilot Removal (PR)

B5 flanges have a centering pilot machined onto the flange. In cases where there is not a matching counter bore or when the flange must sit flush to the mounting surface then the centering pilot must be removed. This pilotless flange is used to firmly secure the speed reducer to the application.

In some cases the matching surface already has a centering pilot and the use of a female pilot (counter bored flange surface) is recommended. Counter rotating drives are an example of where a female pilot is frequently used.



## Shaft Options

### Solid Shaft (V)

NORD's standard keyed solid shafts include a centered threaded hole. Shafts are available in inch or metric versions. The standard shaft materials are AISI1045 high carbon steel, AISI 4140 or an equivalent.

Solid shaft sizes & dimensions are listed on page 140.

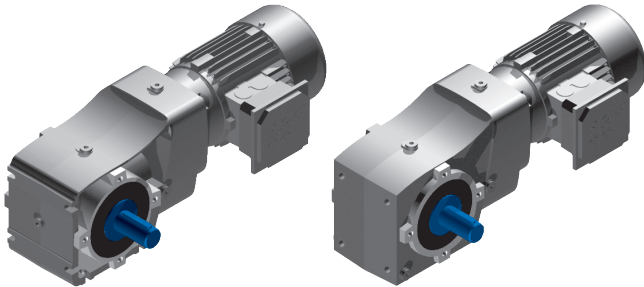

### Keyed Hollow Shaft (A)

NORD's standard keyed hollow shafts are made from AISI 1045 high carbon steel. They feature standard keyway dimensions and are available both inch and metric designs. Many NORD reducers offer a variety of hollow shaft diameters.

Hollow shaft sizes & dimensions are listed on page 141.

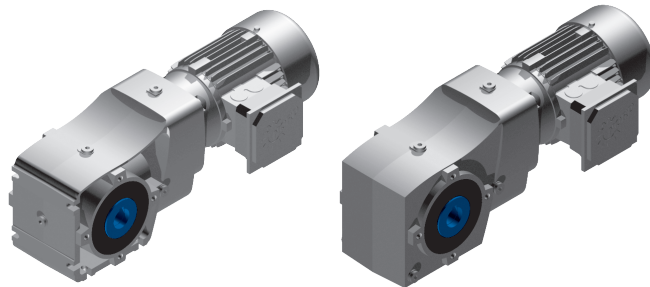

### Double Solid Shaft (L)

The standard solid shaft end is projected out both sides of the speed reducer. This option is commonly used to transfer torque out of both sides of the reducer or to mount a speed-monitoring device such as an encoder on one of the shaft ends.

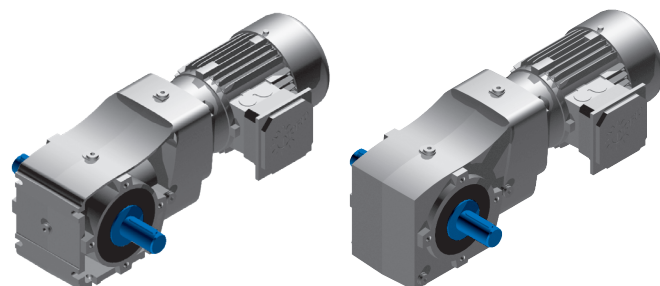

### Shrink Disc & Cover (SH)

The shrink disc relies on the proven wedge principle to create a keyless, mechanical interference fit by converting locking screw tension into radial contact pressure on shaft and hub in effect "shrinking" it on to the customer shaft. Shrink discs result in a zero backlash mechanical interference fit that can accommodate high torque unlike other mounting technologies and will never wear or pound out, even for high cycle fluctuating and reversing loads.

A shaft cover is required with all shrink disc units and provides protection from the rotating shrink disc.

Other shrink disc advantages include:

- Elimination of fretting corrosion associated with key connections.
- Generous clearance for easy mounting & dismantling.
- Allow for larger bores sizes compared to keyed hollow shafts.

Standard sizes are listed on page 142. Please consult NORD for special sizes.

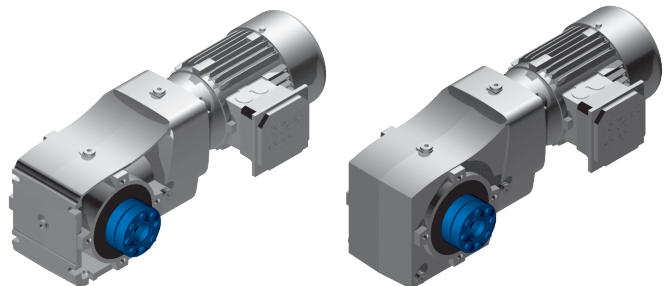

### Hollow Shaft Cover (H)

An optional cover can be used to guard from rotating hollow output shafts. It also protects the output shaft seals against dust and dirt particles and in some cases can be sealed against moisture and dust.

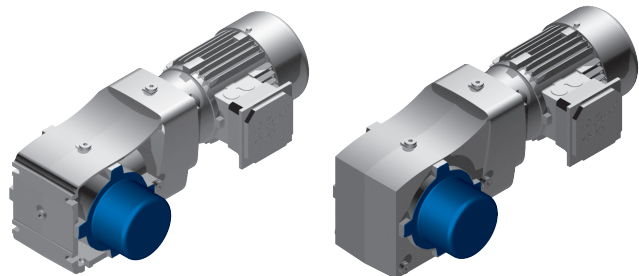



## Special Shafts & Shaft Materials

### GRIPMAXX™ Keyless Bushing System (M)

The GRIPMAXX™ bushing system offers interchangeable keyless bushings to mount NORD hollow shaft reducers onto a large range of driven machine shaft sizes. This option eliminates the challenges of using interference fits by providing generous clearances to ensure easy installation and removal of the gearbox. GRIPMAXX™ provides a high-capacity, zero-backlash, interference fit to the driven machine shaft to minimize the possibility of fretting corrosion.

Torque is transmitted via the NORD Shrink Disc, which produces high compressive forces between the reducer hollow shaft, split-bushing and solid machine shaft.

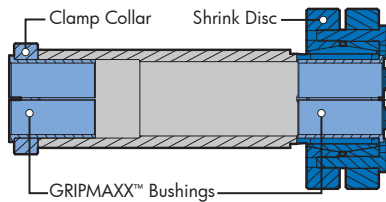

A shaft cover is required with all shrink disc units and provides protection from the rotating shrink disc.

### Stainless Steel Output Shaft

Output shafts made from stainless steel are available and are frequently used in food, pharmaceutical, and washdown applications. In some cases stainless steel solid input shafts may also be provided.

### Special Solid Shaft (SWV)

Special solid shaft diameters and lengths may be provided for a nominal price adder. Other Special features such as keyless shafts, alternate materials, cross-drilled shafts or special threaded taps are also available. NORD has in-house drafting, design and machining departments in order to provide special requirements in short lead times.

### Special Hollow Shaft (SWA)

Special hollow bore shafts may be provided. Hollow bores are offered with special diameters, multiple keyways, and special extended hollow shafts that are used with counter rotating drives. Different shaft materials are also available.

### Fixing Kit (B)

Due to the slight oscillations inherent in any rotating shaft, NORD offers an optional “fixing element kit”. This is a method to prevent the reducer from “walking out” of position. The kit includes all necessary parts to secure the shaft in the axial direction by using a tapped hole in the end of the mating male shaft.

There are two methods for securing the fixing element kit. The first involves pulling the customer supplied male shaft to the snap ring (type 1) and the second method the customer supplied shaft is shouldered (type 2) and pulled against the hollow shaft and not the snap ring.

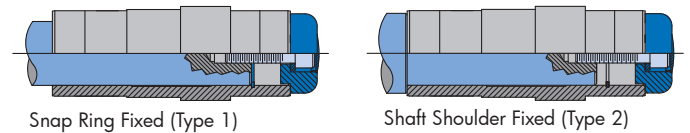

### Torque Arm (D)

A torque arm is a compact, simple way to secure a shaft mounted reducer. It is bolted onto the reducers B14 flange. The tear drop shaped torque arm has a rubber bushing located at the fastening hole-end to act as a shock absorber to dampen out peak shock loads.

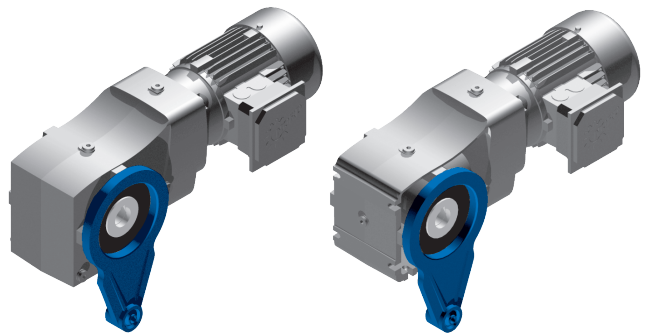

**Specify the torque arm location and orientation when ordering**

Torque arm location \_\_\_\_\_

Torque arm orientation \_\_\_\_\_

See Page 17 for details



## Other Options

### Autovent™ (DR)

The AUTOVENT™ helps prevent bearing and gear damage by behaving like a check valve to block the entry of foreign material and prevent lubrication contamination from dust particles, moisture and air-borne process chemicals. The breather opens at approximately 0.3-0.9 psi during operation and closes tightly as the gearbox cools. This option is perfect for humid conditions and wash-down environments, helping to maintain proper oil cleanliness, while reducing foaming and oxidation.

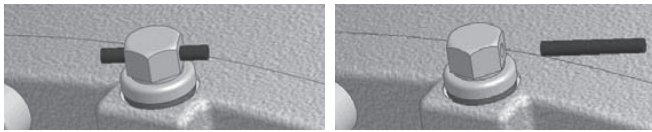

### WARNING



To prevent build-up of excessive pressure, sealed vents must be activated as shown prior to gear unit start-up.

### Open Vent (OV)

A typical gearbox industry open vent option can also be supplied by NORD. This option allows free exchange of air and does not build-up any back pressure inside the gear unit. This option is ideal for many operating conditions where the geared product is used in relatively clean and moisture-free environment.

The standard Open Vent comes with a transportation plug that must be activated or removed prior to gear unit start-up.

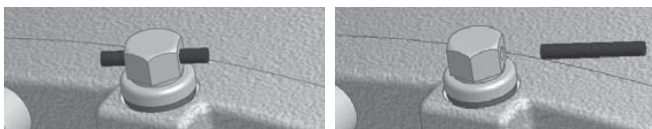

### WARNING



To prevent build-up of excessive pressure, sealed vents must be activated as shown prior to gear unit start-up.

### Filtered Vent (FV)

NORD offers a filtered vent, which allows gases to permeate, but does not allow dust and debris to pass through the vent.

### Fluoro-rubber Seals (FKM)

The NORD standard oil seals are made of Nitrile or rubber and are rated for temperatures up to 125°C or 250°F. If ambient or oil temperatures rise above this level NORD recommends using fluoro-rubber (also called FKM) oil seals. FKM seals are rated from -30°F to 400°F (-35°C to 200°C).

### Oil Sight Glass (OSG)

The oil sight glass provides a visible oil level indication on the reducer. The sight glass replaces the standard steel fill plug and consists of a sealed clear porthole centered in the middle of a brass plug. The sight glass allows for quick oil level and color inspection.





## Magnetic Drain Plug (MDP)

Magnetic drain plugs attract and hold ferrous metal particles that may circulate inside the reducer's oil sump. These potentially abrasive particles may cause excessive wear in the reducer if they remain circulating. An increase of material collected by the magnetic plug may be a warning sign of future problems. The magnetic plug is available for gear unit sizes SK 92672.1/93372.1 and larger.

## Special Drain Plugs

NORD oil drain valves are offered to make draining the oil from the gearbox clean and easy. The drain hose needs to be supplied by the customer. The hose fittings are offered in either 90° or straight to accommodate the user.

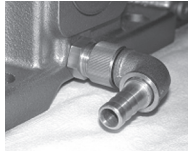

A brass drain valve is threaded into the existing oil drain port of the gearbox. The spring valve is closed using a rubber o-ring. When the hose fitting is threaded into the drain valve, the spring valve is pushed open and allows oil to drain. When the hose fitting is removed, the drain valve closes. A brass, threaded cap is supplied to cover the drain valve when not in use.

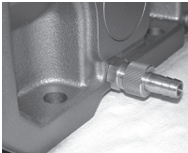

The drain plug fittings are available for gear unit sizes SK 92172.1/93172.1 and larger.

## Additional Drain Plug Hole (ADP)

NORD can add an additional drain hole to the reducer housing for a small surcharge if required for special oil plumbing needs.

## Long Term Storage (LL)

Speed reducers are frequently put in storage prior to installation for long periods of time & in some cases exposed to the elements. NORD's long term storage option protects the unit from moisture or corrosion by coating all unpainted surfaces with a dry, transparent, durable waxy film. Once installation is necessary this waxy film can be easily removed with a commercial de-greaser or petroleum solvent. If possible the store room should be vented and dry, with room temps. between 32°F and 104 °F (0 °C and 40 °C).





## Paint Coatings

NORD's standard paint coating is a two component, aliphatic polyurethane finish containing 316 stainless steel material. This gray stainless steel paint has excellent appearance and outstanding physical properties. It is suitable for both indoor and outdoor applications.

Advantages of NORD's stainless steel two component polyurethane:

- Excellent adhesion to cast iron, aluminum, steel, and plastics
- Excellent corrosion resistance
- Excellent chemical resistance
- Excellent gloss and color retention
- Suitable for indoor and outdoor exposure
- Nonporous and excellent abrasion resistance
- Suitable for use in a USDA inspected facility

NORD also offers a variety of severe duty paint coatings that provide a high level of protection against water and severe environments. NSD+ (NORD Severe Duty) consists of a primer undercoat and a stainless steel polyurethane topcoat. For the most demanding environments, NORD offers NSD-X3 (NORD Severe Duty triple coated) which consists of a primer undercoat, stainless steel polyurethane coating, and a clear topcoat. Paint coatings are also available in alternate colors as seen in the table below.

Finish	Color	Coating	Use
Standard (stainless steel paint)	Stainless steel silver (Gray)	1 x Stainless steel (316) top coat (polyurethane)	Clean and dry operating environments
Alternate color	Black, Blue, Red, Orange	1 x Color top coat (polyurethane)	Clean and dry operating environments

### NSD+

NORD Severe Duty + NSD+	Stainless steel silver (Gray)	1 x Primer high solid alkyd system 1 x Stainless steel (316) top coat (polyurethane)	Modestly wet and more severe operating environment
NORD Severe Duty +W NSD+W	White	1 x Primer high solid alkyd system 1 x White top coat (polyurethane)	Modestly wet and more severe operating environment
Alternate color NSD+	Black, Blue, Red, Orange	1 x Primer high solid alkyd system 1 x Color top coat (polyurethane)	Modestly wet and more severe operating environment

### NSD-X3

NORD Severe Duty Extreme NSD-X3	Stainless steel silver (Gray)	1 x Primer high solid alkyd system 1 x Stainless steel (316) (polyurethane) 1 x Clear top coat (polyurethane)	Wet and washdown operating environments
NORD Severe Duty Extreme NSD-X3W	White	1 x Primer high solid alkyd system 1 x White (polyurethane) 1 x Clear top coat (polyurethane)	Wet and washdown operating environments
Alternate color NSD-X3	Black, Blue, Red, Orange	1 x Primer high solid alkyd system 1 x Color (polyurethane) 1 x Clear top coat (polyurethane)	Wet and washdown operating environments

Special colors and paints possible please contact NORD with your specific requirements.



## NSD TupH

As a leader in the power transmission industry, NORD Gear is committed to providing value to industries where end users demand durable equipment to withstand a variety of harsh environments. The market has long awaited a product with such a large range of standard reducers with the corrosive resistance properties of a stainless steel product without the excessive cost.

In response to these demands, NORD Gear has begun utilizing an electrically catalyzed process to create a uniform case depth protective surface with its existing aluminum alloy housing material. Combined with a sealer, NORD's corrosion resistant cleanable Sealed Surface Conversion system (NSD<sup>tupH</sup>) allows existing aluminum alloy housings to be protected with a base finish that is 6X-7X harder than aluminum alloy. With its stainless steel hardware, optional stainless steel shafts, optional stainless steel motors and optional food grade lubricants, NORD's NSD<sup>tupH</sup> is the optimal package for applications in a variety of incredibly harsh environments.

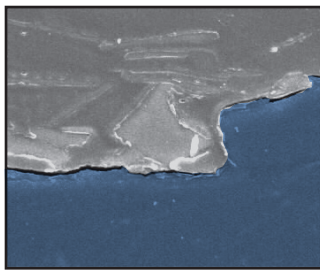

*Paint simply lies on top of the substrate and may even bridge across pores in the metal. Since paint does not form a permanent bond to the substrate, it can easily release at very low stress levels.*

■ Paint      ■ Aluminum Surface

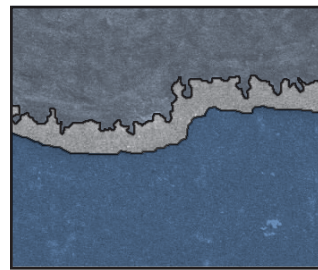

*The NSD<sup>tupH</sup> process includes a base layer that is permanently bonded to the substrate and provides a powerful foundation for adhesion of the surface sealant. This foundation provides excellent roughness, is 6-7x harder than the aluminum substrate and up to 1000x harder than paint.*

■ Sealer      ■ Aluminum Surface  
■ Surface Conversion

## nsd<sup>tupH</sup> System Package

- Standard Electrolytic processed reducer housing
- Standard Stainless Steel Hardware
- Standard C-Face Gasket included
- Housings surfaces are self draining
- Food Grade H1 Synthetic Lubrication (optional)
- Stainless Steel output shafting (optional)
- Stainless Steel C-Face Inverter Duty motor up to 10HP (optional)
- 3 Year Warranty when supplied with synthetic lube

### nsd<sup>tupH</sup> is Useful in Many Harsh Environments

(not limited to but including)

- Chemical wash down
- Damp and wet environments
- Marine / Coastal
- Food & Beverage industry
- Car Wash
- Dairy
- Pharmaceutical
- Water and waste treatment

### Some of the Many Benefits of nsd<sup>tupH</sup>

- Cost effective alternate to stainless steel
- Corrosion resistance
- Chip resistance
- Non propagating from scratches or other blemishes
- Highly Cleanable low friction surface
- Non-porous
- Lighter than stainless
- Chemical resistant
- Elimination of galvanic corrosion
- Surface conversion is 1000X harder than paint



## Input

NORD's modular design allows for many different types of inputs to be added to gear reducers. All inputs are bolt on and include machined pilots to ensure simple and accurate assembly. NORD offers the following different input types:

- Integral motor
- Solid input shaft
- NEMA C-face motor adapter
- IEC motor adapter
- Custom mounting interface

## Integral Motors

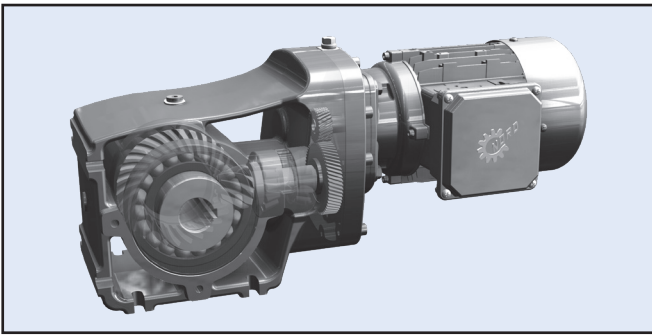

NORD provides integral motors that mount directly to the gearbox. Integral motor mounting eliminates the need for costly v-belts or sheaves and directly couples the motor to the reducer. This also results in a dimensionally compact one-piece package.

NORD high performance integral motors are available in many operational voltages, are inverter duty rated, and offer many valuable options including energy efficient motors and power off brakes. For more information on integral motors, see the catalogs motor section found on page 145.

## Solid Input Shaft

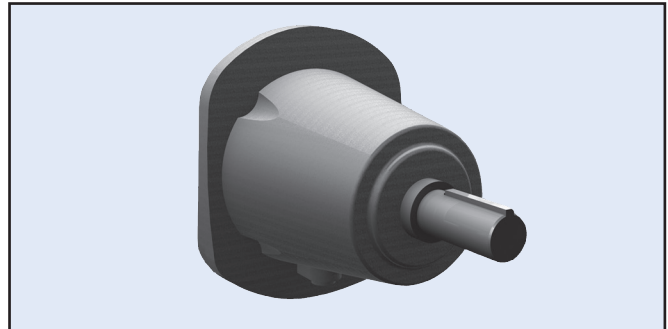

Designed to mount couplings, sheaves or sprockets, which transfer torque from the prime mover. The input shaft is made from ANSI 1045 or stronger material dimensioned with long keys according to ANSI B17 standards. Bearings are sized to handle overhung loads resulting from belt or sprocket inputs. See page 44 for more information on the capacity of each input housing assembly. The maximum gearbox input power rating is indicated in the speed reducer performance tables.

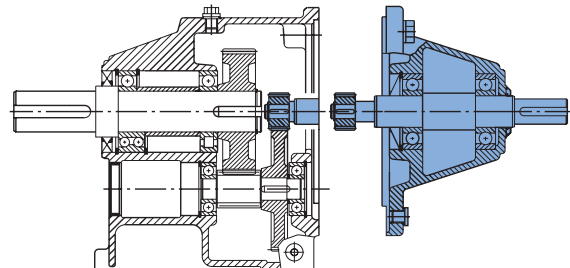





## NEMA C-Face Motor Adapter

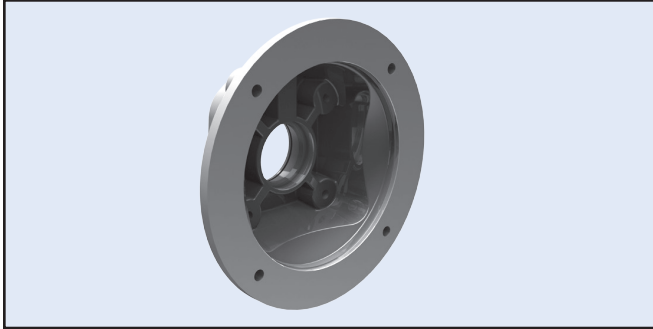

NEMA C-face motor adapters allow for easy installation and removal of industry standard C-face motors. NEMA C-face motor adapters consist of a coupling and an adapter housing that connects the motor to the gear reducer. Gear units with NEMA C-face adapters are commonly used when the application require specialized motors or when the user wants to easily replace a motor if failure occurs. NORD also offers high performance NEMA C-face motors and brakemotors, that can be factory installed to the motor adapter.

NORD motor adapters deliver nearly 100% of the torque generated by the motor and can be used from -13°F (-25°C) to 212°F (100°C). Most motor adapters have specially sealed bearings that are lubricated for life.

The maximum input power of a gear unit with a NEMA C-face adapter is generally limited by the power rating of the standard NEMA C-face motor size. The power limit is indicated in the ratings table for a standard 4-pole 1750 rpm motor. In some cases the gearbox limit ( $T_{2_{max}}$ ) will be the limiting capacity. Both the NEMA adapter limit and the gearbox torque limit must be considered. If the speeds required exceed those included in the performance and speed reduction tables please contact NORD.

## IEC Motor Adapter

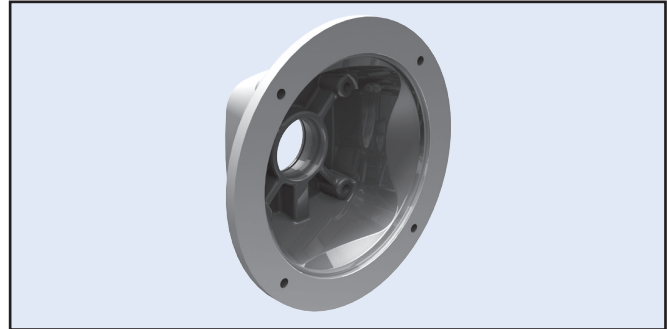

IEC motor adapters allow for easy installation and removal of industry standard IEC motors. The IEC adapter is very similar to the NEMA C-face adapter in construction. The maximum input power is generally limited by the IEC motor size. For ratings and dimensions, please consult NORD's metric catalogs found online at [www.nord.com](http://www.nord.com).





## Couplings

Couplings are made with tough abrasion resistant materials, which resist most chemicals and petroleum products. They are electrically isolated (prevent metal to metal contact) and require no lubrication or maintenance.

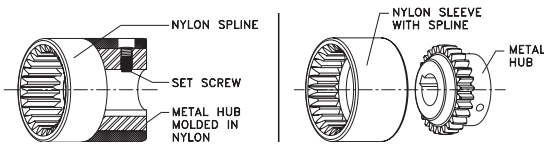

## Gear Couplings

Gear couplings are used with 56C to 250TC adapters and provide a compact space saving design. C-face adapter input shafts have a machined male spline that meshes with a molded nylon spline on the coupling. This specially designed molded nylon sleeve that exhibits high torsional stiffness, resulting in minimum fit-up backlash and reduced internal frictional losses. Gear couplings lightweight design yields low inertia and use blind assembly and slip together components to make inspection easy without disassembly.

NORD incorporates two styles of gear couplings, the "J" and "M" styles. The "J" style is a one-piece coupling consisting of a nylon sleeve and metal hub that is fused together. The "M" style is a two-piece coupling consisting of a separate nylon sleeve and metal hub.

**NEMA Motor Adapter Details**

NEMA C-face Motor Frame Size	NEMA Adapter Nomenclature	4 pole Motor HP	Max Motor Weight [lb]	Coupling Description	Coupling Bore (inches)	Maximum Coupling Torque Capacity (in-lb)	Safety Factor
56 C	- 56C	≤ 1.0	66	J14	0.625	177	3.3 min
56 C	- 56C	≤ 1.5	66	J24	0.875	354	6.6 min
143 TC	- 140TC	≤ 1.5	88				6.6 min
145 TC	- 140TC	≤ 2	110				4.9 min
145 TC	- 140TC	3	110				3.3 min
182 TC	- 180TC	3	130	J28	1.125	797	7.4 min
184 TC	- 180TC	5	175				4.4 min
182 TC	- 180TC	3	130	M38	1.125	1416	13.1 min
184 TC	- 180TC	5	175				7.9 min
213 TC	- 210TC	7.5	220		1.375		5.2 min
215 TC	- 210TC	10	220				4.0 min

**IEC Motor Adapter Details**

IEC Motor B5 4 pole	IEC Adapter Nomenclature	HP / kW	Max Weight Limit [lb]	Coupling Description	Coupling Bore (mm)	Maximum Coupling Torque Capacity (Nm)	Safety Factor
63 S/4	- IEC 63	0.16 / 0.12	56	J14	11	20	23.2 min
63 L/4	- IEC 63	0.25 / 0.18	56				15.8 min
71 S/4	- IEC 71	0.33 / 0.25	67		14		11.5 min
71 L/4	- IEC 71	0.50 / 0.37	67				7.8 min
80 S/4	- IEC 80	0.75 / 0.55	89	J24	19	40	10.4 min
80 L/4	- IEC 80	1.00 / 0.75	89				7.6 min
90 S/4	- IEC 90	1.5 / 1.1	111		24		5.3 min
90 L/4	- IEC 90	2.0 / 1.5	111	3.8 min			
100 L/4	- IEC 100	3.0 / 2.2	133	J28	28	90	6.1 min
100 L/40	- IEC 100	5.0 / 3.7	133				4.4 min
112 M/4	- IEC 112	5.3 / 4.0	177				3.4 min
132 S/4	- IEC 132	7.5 / 5.5	221	M38	38	160	4.3 min
132 M/4	- IEC 132	10 / 7.5	221				3.2 min



### Custom Mounting Interface

NORD can provide custom input adapters typically consisting of a special adapter plate and special coupling to mount non-standard dimensioned motors or other devices.

- Motor Dimensional Drawing
- Motor Weight
- Motor performance specifications, including torque, horsepower and operating speed ranges.

When a custom input adapter is required, special attention needs to be given for each application to be sure the customer receives the performance that is necessary. The following information is required:

NORD engineers will review the performance requirements and make a unit selection based on given parameters.

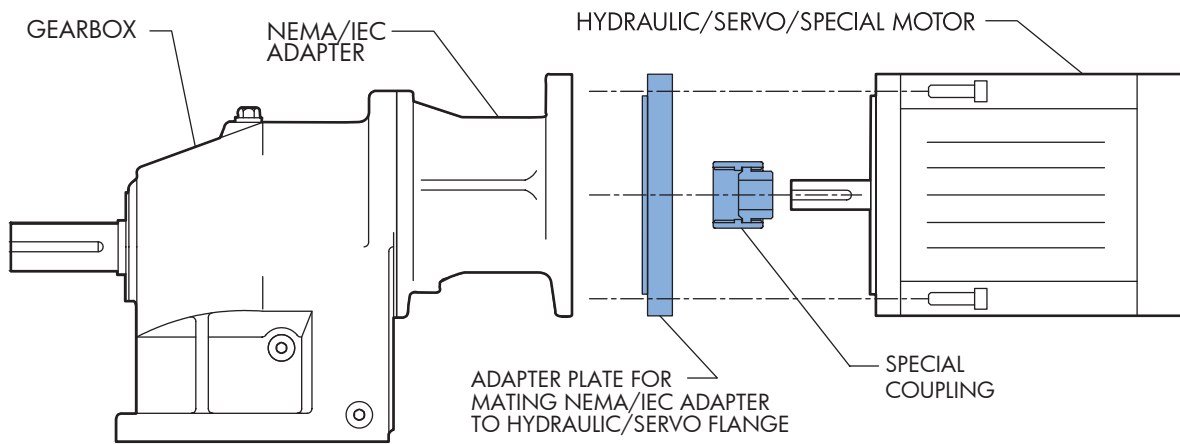



## The Importance of Proper Lubrication

Proper gearbox lubrication is essential in order to reduce friction and component wear, and protect against corrosion and rust. Gear lubricants reduce heat and wear by inserting a load-sharing “protective fluid film” between mating parts and preventing direct metal to metal contact. Properly selected lubricants will operate under various film conditions, improve heat transfer, optimize reducer efficiency, absorb shock loads, reduce noise, inhibit foaming, and separate water readily.

## Design Considerations

Along with many other factors, the gear designer must consider the type of gearing (helical, bevel, worm, etc.), the gear load and speed conditions, and the expected operating oil temperatures. These factors help determine a generally suitable oil category, a desired additive package, preferred base-oil type, and oil viscosity.

It is important that the consumer be aware of these many design factors before making any changes in the critical areas (oil category, base-oil type, viscosity, etc.) One should consult their preferred lubrication supplier or NORD Gear when questions arise.

## Gear Oil Types, Categorized by Base Oil

### *Mineral Oil with an EP Additive (DIN 51517, Type CLP)*

High performance mineral gear oils are carefully engineered and manufactured to improve aging characteristics, minimize friction, offer good wear protection, provide corrosion and oxidation resistance, minimize foam, and separate water. Mineral gear oils are classified as API Group I or II oils, depending upon viscosity.

The standard NORD mineral gear oil has an extreme pressure (EP) additive ISO Viscosity Grade EP220 (AGMA 5 EP) and is generally acceptable for helical and helical-bevel gear units. Good quality mineral oil should have the ability to operate at moderate sump temperatures (up to 80-85 °C) without losing viscosity or thickness. A minimum viscosity index (VI) of 93 or higher is suggested. The oil must also have good film strength to handle shock loads, high torque, and start-up conditions. A minimum FZG Scuffing Load Stage 12 is desirable.

## Advantages:

- Most economical of all the gear oil types.
- Generally offers good compatibility with shaft seals, gaskets, paint finishes, etc.
- Offers good corrosion and oxidation protection.
- Effectively reduces internal friction and wear.

## When Synthetic Oils Are Used

Synthetic gear oils are suggested when mineral gear oils have reached their performance limit or when they no longer meet certain application requirements. NORD may recommend synthetic oil for any one of the following conditions:

- Severe duty applications or when gears are exposed to frequent starts and stops, high-load or shock.
- For applications in low or high temperature service.
- To extend oil service interval requirements.
- To eliminate the necessity for seasonal oil changes.
- To extend service life of factory-sealed or maintenance-free gear units.
- To take advantage of performance benefits: shear resistance, low traction coefficient, reduced internal friction, improved lubricity, reduced operating temperatures, improved gear efficiency, etc.

## Performance Advantages of Synthetic Oil

Compared to mineral oils, synthetic oils provide a number of performance advantages including:

- Ability to operate at higher temperatures without losing viscosity or thickness, due to a much improved viscosity index.
- Improved low-temperature stability due to a lower pour point
- Increased oil change intervals due to superior oxidative and wear resistance
- Lower tendency to form residues and increased resistance to foaming.
- Other benefits may include: very good shear resistance, low traction coefficient, reduced internal friction, improved lubricity, reduced operating temperatures, improved gear efficiency, and extended component life and wear protection.

When application conditions warrant the use of synthetic oil, NORD may suggest a particular type of synthetic oil, depending upon the gear unit type and the application.





## **Synthetic Hydrocarbon/Polyalphaolefin (SHC/PAO) Oil (DIN 51517, Type CLP-HC)**

Synthetic Hydrocarbons (SHC) or Polyalphaolefin (PAO) synthetic base oils offer good miscibility with mineral base oils and are very readily available. SHC/PAO oils are classified as API Group IV oils. They can be formulated with or without anti-wear (AW) or extreme pressure (EP) additives. They can also be formulated for acceptance in food-grade applications.

### **Advantages:**

- Higher viscosity index and therefore greater high-temperature stability than mineral oil.
- Better low-temperature stability and lower pour point than mineral type gear oils
- High surface tension and lower tendency to foam compared to mineral oil, and water-soluble polyglycol gear oils.
- Compatible (miscible) with mineral oil.
- Better water separability demulsibility than PG oils.

## **Polyalkylene Glycol or Polyglycol Synthetic Oil (DIN 51517, Type CLP-PG)**

Polyalkylene glycol or polyglycol (PAG or PG) synthetic gear oils are made readily available through many lubrication suppliers. PG oils are classified as API Group V gear oils. They can also be formulated for acceptance in food-grade applications.

PG gear oils possess extremely low traction coefficients and a viscosity index higher than any of the other synthetics (often greater than 220 VI), resulting in excellent heat resistant, shear stability, and natural anti-wear properties.

Typical PG gear oils are formulated with a 1:1 or higher ratio of ethylene oxide to propylene oxide (50:50 or 60:40 is common); this makes PG gear oils water soluble, providing them with very good corrosion resistance even when water is present in concentrations that are higher than what is normally allowed.

### **Advantages:**

- PG oils offer the highest viscosity index of any other synthetic resulting in excellent heat resistant, shear stability, and superior natural anti-wear properties without requiring EP-additives.
- PG gears oils minimize internal friction and often result in improved gear efficiency.
- PG oils have significantly higher film strength than mineral and SHC/PAO oils and out perform these oils at higher operating oil temperatures (approaching 80°C or higher).



### **CAUTIONS**



Polyglycol (PG) oils are not miscible with other oil types and should never be mixed with mineral oil, hydrosynthesized synthetic or PAO synthetic oils.





## Food-Grade Lubricants

Food-grade lubricants should be manufactured in compliance with FDA 212 CFR 178.3570 and should either satisfy the former 1998 USDA Guidelines as an H1 lubricant or currently qualify as a NSF-H1 lubricant. Please consult with lubrication manufacture for more information or visit [www.nsf.org](http://www.nsf.org)

H1 food grade oil can only contain additives which appear on the FDA “approved list” for food safe compounds. H1 oils are generally absent of common zinc-based AW additives, and sulfur-phosphorus based, EP chemistries, commonly found in many industrial gear oils.

Food manufactures control risk and liability by following detailed guidelines outlined by the HACCP (Hazard Analysis and Critical Control Point) program, which includes food-grade H1 lubricants.

Food grade H1 lubricants may be formulated as highly refined mineral oils (white oils), SHC/PAO synthetic oils or PG synthetic oils.

The highly refined nature of good-quality food-grade white-oils provides good long-term oxidative stability and in most cases adequate lubrication under high-load (boundary) conditions. So long as food-grade white oils meet the minimum anti-wear requirements of the normally specified non-food grade oil, they are often acceptable.

Both food-grade white oils and PAO’s have an inherent “purity” and absence of polar compounds, making them better than the average mineral oil or even PG oil in terms of demulsibility (water seperability).

Compared to food-grade white-oils, food-grade synthetic PAO or PG oils typically provide:

- Better wear and oxidation resistance.
- Improved high-temperature characteristics.
- Better cold-temperature behavior.

## Maximum Oil Sump Temperature Limit

To prevent reducer overheating, the reducer’s maximum oil sump temperature limit must not be exceeded for prolonged periods of operation (up to 3 hours continuous operation, depending upon reducer size).

Oil Type	Maximum Oil Temperature Limit	
	NORD	AGMA 9005-D94
Mineral	80-85 °C (176-185 °F)	95 °C (203 °F)
Synthetic	105 °C (220 ° F)	107 ° C (225 ° F)

## Oil Viscosity

The viscosity rating determines the operating oil’s resistance to shear under load conditions. Some important viscosity considerations include the following:

- Lightly loaded gears require lower viscosity oils than highly loaded gears.
- Lower viscosity will provide thin oil film, lower friction, higher mechanical efficiency, and better heat removal conditions.
- Higher viscosity will provide thicker oil film, and better resistance to sliding wear, scuffing wear, and galling at high pressure.
- Higher operating temperatures will cause a reduction in viscosity and lower operating temperatures, cause an increase in viscosity or a thickening of the oil.

The standard oil-fill is considered acceptable for most applications. In certain situations an oil viscosity change may be beneficial.

- If the gear unit is exposed to frequent high load conditions. A higher viscosity oil will have a higher film thickness offering better overall resistance to oil shear, sliding wear and scuffing wear in gears and roller element bearings.
- An oil viscosity correction or lubrication change may improve the overall performance when operating the gear unit at very low or high ambient temperature conditions.

## Viscosity Index

Viscosity index helps quantify the rate of oil viscosity change with respect to temperature changes. Oils with a reasonably high viscosity index tend to be more stable in a changing temperature environment. The ability of an oil to maintain a small viscosity differential over the operating range of the gearbox provides a more consistent lubricating film and better wear performance.

Synthetic oils typically have a higher viscosity index than mineral oils and polyglycol oils tend to have an exceptionally high viscosity index compared to other synthetic oils like polyalphaolefin or ester based products.



## Ventilation

Most gear reducers are equipped with a vent which helps compensate for air pressure differences between the inner space of the gear unit and the atmosphere.

The spring-pressure vent (Autovent™) is commonly supplied and factory-installed. Normally open vents may also be supplied as an option; normally-open vents are closed upon delivery in order to prevent oil leakage during transport. When normally open vents are supplied, the sealing plugs must be removed prior to commissioning the reducer.

Prior to reducer start-up, it is important to check the maintenance manual to verify that the vent is properly located with respect to mounting position.

## Mounting Position

The reducer mounting position determines the approximate oil fill-level and the appropriate vent location. In some cases mounting position may dictate possible variation in final reducer assembly.

If considering any mounting positions that are not shown as catalog-standard options, it is critical that the customer consult with NORD prior to ordering.

## Oil Fill Quantities

Oil fill quantities shown in the catalog or maintenance instructions are approximate amounts. The actual oil volume varies depending upon the gear ratio. Prior to commissioning the reducer, the oil-fill level should be checked using the reducer's oil-level plug. It may be necessary to drain excess oil or add additional oil.

Unless otherwise specified, NORD supplies most all gear units factory-filled with the standard lubrication type per the specified mounting position.

## Lubrication Replacement

If the gear unit is filled with mineral oil, the lubricant should be replaced at least after every 10,000 operating hours or after every two years. If the gear unit is filled with synthetic oil, the lubricant should be replaced at least after every 20,000 operating hours or after every four years. Often gear reducers are exposed to extreme ambient conditions, hostile environments, wet conditions, or dirty and dusty operating areas. Especially in these situations, it is important to establish a condition-based oil service interval.

## The Importance of Routine Oil Analysis

Routine oil analysis, sound lubrication practices, and good tracking of oil performance trends will help establish proper lubrication maintenance and change-out intervals. To maximize equipment reliability, NORD Gear generally recommends a condition-based lubrication maintenance program. One may take exceptions to this general recommendation on sealed-for-life or maintenance-free gear units or smaller and less costly gear units. In these instances, the replacement cost of the gear unit is often small compared to the costs associated with this type of oil analysis program.

NORD suggests replacing the gear oil if oil analysis indicates any of the following:

- Viscosity has changed by approximately 10% or more.
- Debris particles (silicon, dust, dirt or sand) exceed 25 ppm.
- Iron content exceeds 150-200 ppm.
- Water content is greater than 0.05% (500 ppm).
- The total acid number (TAN) tests indicate a significant level of oxidative break-down of the oil, and a critical reduction in performance; If the TAN number measured changes by more than 5% over the new oil, then an oil change would be recommended.



## Lubrication Types

Proper gearbox lubrication is essential in order to reduce friction, heat, and component wear. Lubricants reduce heat and wear by inserting a protective “fluid boundary” between mating parts and preventing direct metal to metal contact. Lubricants also help prevent corrosion and oxidation, minimize foam, improve heat transfer, optimize reducer efficiency, absorb shock loads and reduce noise.

Mounting position not only determines the proper fill-level but may also have some effect on final reducer assembly. If considering any mounting positions that are not shown as catalog-standard options, it is critical that the customer consult with NORD prior to ordering. Unless otherwise specified, NORD supplies all 92 Bevel gear units factory-filled with the standard mineral lubrication type and the appropriate quantity.

### Standard Oil Lubricants

Gear Unit Type	ISO Visc.	Oil Type	Ambient Temp. Range	Manufacturer/Type	Notes
92.1/93.1 Bevel	VG220	MIN-EP	0 to 40°C (32 to 104°)	Mobilgear 600XP220	♠♠
	VG220	PAO-EP	-35 to 60°C (-31 to 140°F)	Mobil SHC Gear 220	♠
	VG220	FG	-5 to 40°C (23 to 104°F)	Fuchs FM220	♠

### Optional Oil Lubricants

Gear Unit Type	ISO Visc.	Oil Type	Ambient Temp. Range	Manufacturer/Type	Notes
92.1/93.1 Bevel	VG460	PAO-EP	-35 to 80°C (-31 to 176°F)	Mobil SHC Gear 460	-
	VG460	FG-PAO	-35 to 80°C (-31 to 176°F)	Mobil SHC Cibus 460	-
	VG220	FG-PAO	-35 to 60°C (-31 to 140°F)	Mobil SHC Cibus 220	-
	VG150	PAO-EP	-35 to 25°C (-31 to 77°F)	Mobil SHC Gear 150	-

### Standard Bearing Grease Lubricants

Grease Thickener	NLGI Grade	Grease Type	Ambient Temperature Range	Manufacturer/Type	Notes
Li-Complex	NLGI 2	MIN	-30 to 60°C (-22 to 140°F)	Mobil Grease XHP222	♠♠
Li-Complex	NLGI 2	PAO	-40 to 80°C (-40 to 176°F)	Mobil / Mobilith SHC 220	♠
Polyurea	NLGI 2	FG-PAO	-30 to 80°C (-22 to 176°F)	Mobil SHC Polyrex 222	♠

♠ Stocked Lubricants

♠ Standard Oil Fill

### Oil Type Codes

MIN-EP	Mineral Oil with EP Additive
PAO	Synthetic Polyalphaolefin Oil
PAO-EP	Synthetic Polyalphaolefin Oil with EP Additive
FG	Food-Grade Oil
FG-PAO	Food-Grade, Synthetic Polyalphaolefin Oil



## IMPORTANT NOTES



- Food grade lubricants must be in compliance with FDA 212 CFR 178.3570 and qualify as a NSF-H1 lubricant. Please consult with lubrication manufacturer for more information.
- When making a lubrication change, check with the lubrication supplier to assure compatibility and to obtain recommended cleaning or flushing procedures.
- Do not to mix different oils with different additive packages or different base oil formulation types. Polyglycol(PG) oils are not miscible with other oil types and should never be mixed with mineral oil.
- Consult NORD if considering oils of ISO Viscosity VG100 or lower.



## Oil plug locations

Prior to commissioning the reducer, check the oil-fill level using the reducer's oil-level plug and drain or add additional oil as needed. *For mounting orientations other than shown please consult NORD Gear. New plug locations may be required.*

### 92.1 Series

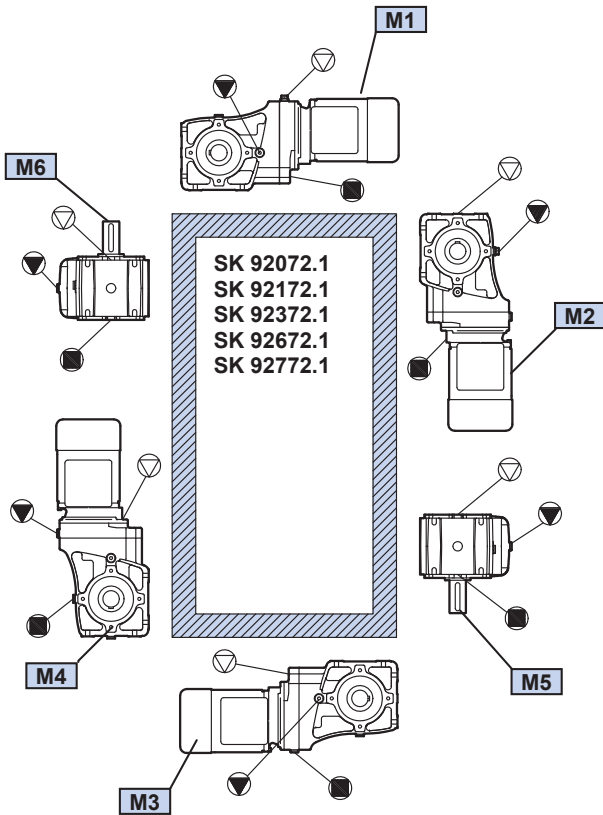

### 93.1 Series

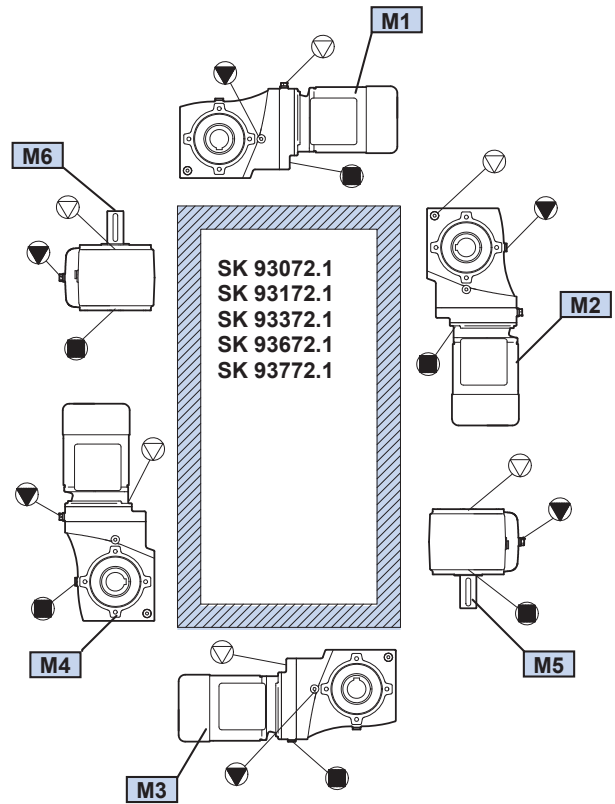

▽ = Vent

▼ = Oil Level

■ = Oil Drain

# 2 Stage Bevel Foot Mount Positions & Oil Fill Quantities



INTRODUCTION

## 92.1/93.1 Helical-bevel foot mount lubrication

All NORD Gear reducers are shipped from the factory with a pre-determined oil fill level in accordance to the specified reducer size and mounting position. For additional information, please refer to the "Oil Plug & Vent Locations" documentation for your gear unit.



### HARMFUL SITUATION



Actual oil volume can vary slightly depending upon the gear case size, mounting and ratio. Prior to commissioning the reducer, check the oil-fill level using the reducer's oil level plug and drain or add additional oil as needed.

For mounting orientations other than shown please consult NORD Gear. Reducer modifications may be required.

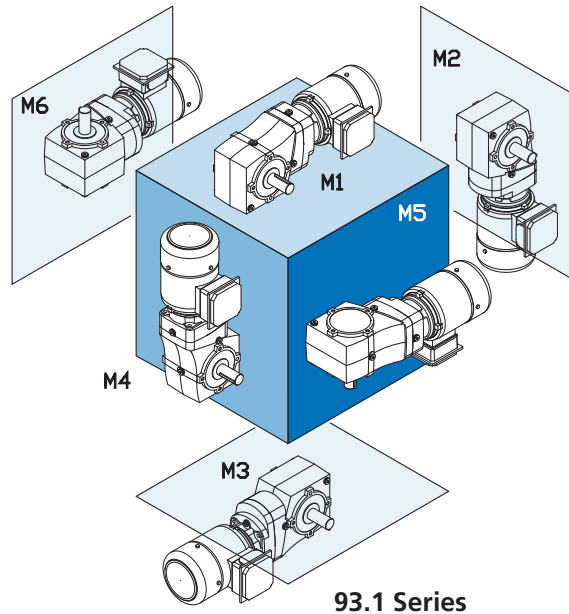
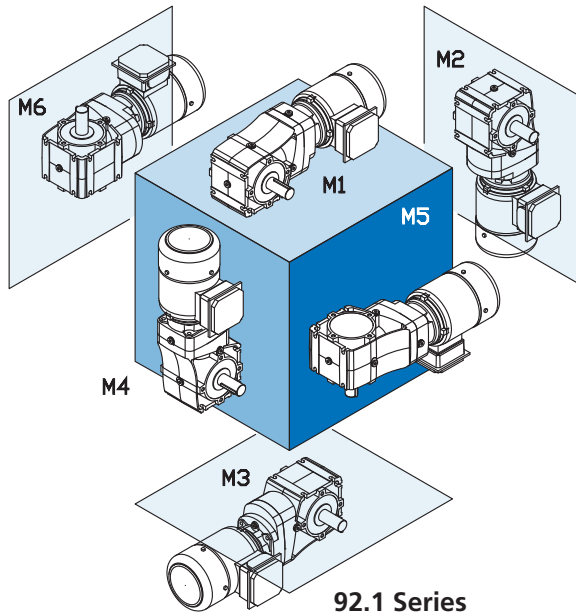

#### 92.1 Series Oil Fill

	M1		M2		M3		M4		M5		M6	
	Quarts	Liters	Quarts	Liters	Quarts	Liters	Quarts	Liters	Quarts	Liters	Quarts	Liters
SK 92072.1	0.28	0.26	0.52	0.49	0.44	0.42	0.57	0.54	0.31	0.29	0.33	0.31
SK 92172.1	0.36	0.34	0.65	0.61	0.55	0.52	0.71	0.67	0.44	0.42	0.51	0.48
SK 92372.1	0.45	0.43	0.97	0.92	0.77	0.73	0.88	0.83	0.58	0.55	0.65	0.61
SK 92672.1	0.90	0.85	1.69	1.60	1.27	1.20	1.59	1.50	1.08	1.02	1.08	1.02
SK 92772.1	1.37	1.30	2.80	2.65	1.97	1.86	2.85	2.70	1.69	1.60	1.69	1.60

Oil levels shown apply to all foot-mounted units.

#### 93.1 Series Oil Fill

	M1		M2		M3		M4		M5		M6	
	Quarts	Liters	Quarts	Liters	Quarts	Liters	Quarts	Liters	Quarts	Liters	Quarts	Liters
SK 93072.1	0.41	0.39	0.98	0.93	0.83	0.79	1.08	1.02	0.52	0.49	0.66	0.62
SK 93172.1	0.63	0.60	1.24	1.17	0.99	0.94	1.29	1.22	0.69	0.65	0.90	0.85
SK 93372.1	1.06	1.00	2.08	1.97	1.74	1.65	2.26	2.14	1.18	1.12	1.42	1.34
SK 93672.1	1.90	1.80	3.41	3.23	2.86	2.71	4.02	3.80	2.13	2.02	2.59	2.45
SK 93772.1	2.87	2.72	4.89	4.63	3.91	3.70	6.13	5.80	3.10	2.93	3.43	3.25

Oil levels shown apply to all foot-mounted units.



# 2 Stage Bevel Flange Mount Positions & Oil Fill Quantities

## 92.1/93.1 Helical-bevel flange/shaft mount lubrication

All NORD Gear reducers are shipped from the factory with a pre-determined oil fill level in accordance to the specified reducer size and mounting position. For additional information, please refer to the "Oil Plug & Vent Locations" documentation for your gear unit.



### HARMFUL SITUATION



Actual oil volume can vary slightly depending upon the gear case size, mounting and ratio. Prior to commissioning the reducer, check the oil-fill level using the reducer's oil level plug and drain or add additional oil as needed.

For mounting orientations other than shown please consult NORD Gear. Reducer modifications may be required.

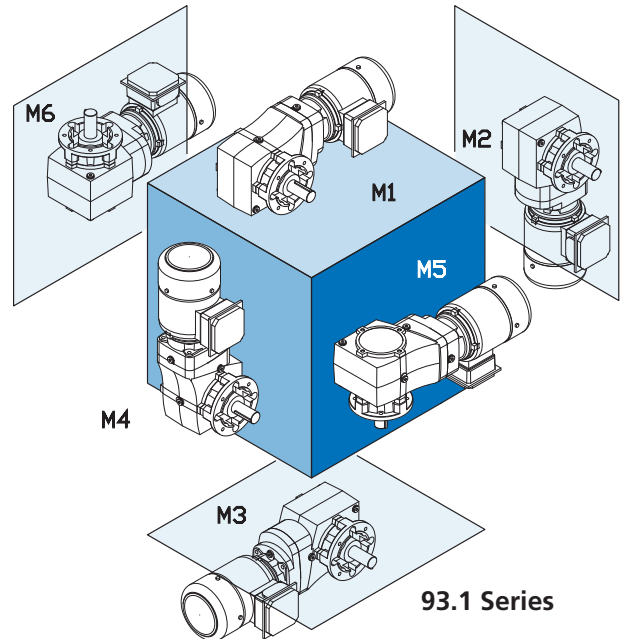
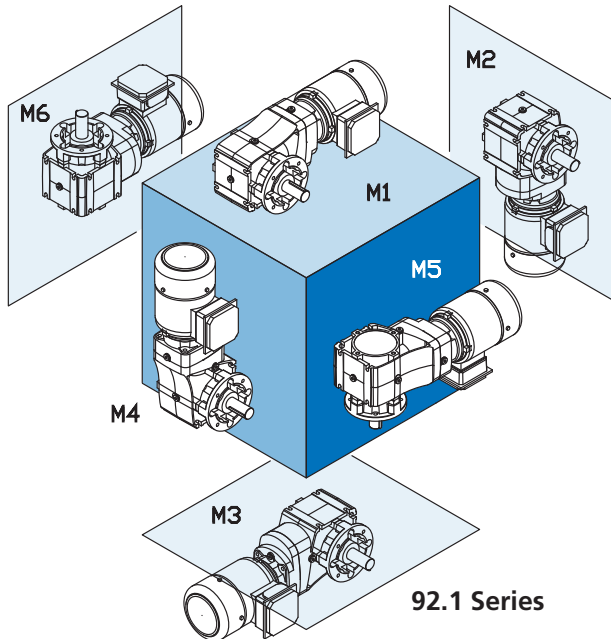

92.1 Series Oil Fill

	M1		M2		M3		M4		M5		M6	
	Quarts	Liters	Quarts	Liters	Quarts	Liters	Quarts	Liters	Quarts	Liters	Quarts	Liters
SK 92072.1	0.28	0.26	0.52	0.49	0.44	0.42	0.57	0.54	0.31	0.29	0.33	0.31
SK 92172.1	0.36	0.34	0.65	0.61	0.55	0.52	0.71	0.67	0.44	0.42	0.51	0.48
SK 92372.1	0.45	0.43	0.97	0.92	0.77	0.73	0.88	0.83	0.58	0.55	0.65	0.61
SK 92672.1	0.90	0.85	1.69	1.60	1.27	1.20	1.59	1.50	1.08	1.02	1.08	1.02
SK 92772.1	1.37	1.30	2.80	2.65	1.97	1.86	2.85	2.70	1.69	1.60	1.69	1.60

Oil levels shown apply to all flange & shaft mounted units.

93.1 Series Oil Fill

	M1		M2		M3		M4		M5		M6	
	Quarts	Liters	Quarts	Liters	Quarts	Liters	Quarts	Liters	Quarts	Liters	Quarts	Liters
SK 93072.1	0.41	0.39	0.98	0.93	0.83	0.79	1.08	1.02	0.52	0.49	0.66	0.62
SK 93172.1	0.63	0.60	1.24	1.17	0.99	0.94	1.29	1.22	0.69	0.65	0.90	0.85
SK 93372.1	1.06	1.00	2.08	1.97	1.74	1.65	2.26	2.14	1.18	1.12	1.42	1.34
SK 93672.1	1.90	1.80	3.41	3.23	2.86	2.71	4.02	3.80	2.13	2.02	2.59	2.45
SK 93772.1	2.87	2.72	4.89	4.63	3.91	3.70	6.13	5.80	3.10	2.93	3.43	3.25

Oil levels shown apply to all flange & shaft mounted units.



## Radial Overhung Load (OHL)

Any radial force or side force applied to the reducer shaft is a source of OHL and should be examined during the reducer selection process. An overhung load is a radial force that pulls (or pushes) against the reducer's output (or input) shaft.

OHL is produced by one or more of the following conditions:

- Transferring power at a right angle to the reducer's shaft, through an externally mounted power transmission device, such as a belt pulley, chain sprocket, or gear.
- By tensioning of the external belt or chain, which is required to keep belts from slipping, or to assure proper chain wrap around sprockets.
- The hanging weight of a pulley, sprocket or gear, mounted on the reducer shaft.

$$F_{\text{OHL}} = \text{Applied overhung load condition at output shaft [lb]}$$

### OHL Rating – General Conditions

The catalog OHL ratings are based upon the following:

- The applied OHL is at the midpoint of the shaft.
- The worst-case direction of shaft rotation.
- There are no axial or thrust load conditions applied to the reducer shaft.

### Output Shaft OHL Rating

The maximum permissible output shaft OHL rating is found in the gearmotor selection tables. Output shaft OHL ratings apply to integral gearmotors, C-face reducers, and reducers with solid input shaft.

This is done by identify the power of the gear unit's driving motor or prime mover, and then using the selection tables to match the output shaft OHL rating with the selected gear unit type, power, ratio and output speed condition.

$$F_{\text{R}} = \text{Output shaft OHL rating, at shaft center [lb]}$$

### Input Shaft OHL Rating

For evaluation of input shaft OHL conditions please contact NORD Gear.

## Axial Load or Thrust Load

Loads that are directed towards or away from the gearbox, along the axis of the shaft, are considered to be axial loads and are more commonly called thrust loads. Thrust loads can result from the following conditions:

- There is a hanging weight connected to the reducer shaft. This is common in mixer applications.
- While operating the equipment, a net axial force is directed towards or away from the reducer, along the shaft axis. This is common in many screw conveyor or mixer applications.

$$F_{\text{THRUST}} = \text{Applied axial thrust load condition at output [lb]}$$

### Thrust Rating – General Conditions

The published thrust ratings are based upon the following:

- The thrust capacity shown represents the worst case, and is independent of direction.
- Application loads can not exceed the values shown in the tables.
- There is no applied overhung load on the shaft.

### Output Shaft and Input Shaft Thrust Rating

The output shaft thrust capacity can be found in the gearmotor selection tables, adjacent to the OHL ratings.

$$F_{\text{A}} = \text{Output shaft thrust rating [lb]}$$

For evaluation of input shaft thrust load conditions please contact NORD Gear.



### IMPORTANT NOTE



To validate the gear unit selection, assuming negligible OHL, the applied thrust condition must be less than the shaft thrust rating.

### Combined OHL and Thrust Load Conditions

Published values for both overhung load and thrust capacity are based upon the presence of a single condition and assume the other condition is absent from the application. In many applications, it is feasible to have both overhung load and thrust at the same time.

*Please contact NORD for more exact examination of the application, when both OHL and thrust conditions exist at the same time.*

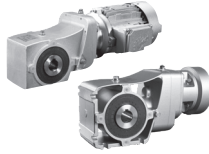

## 1. Calculate the applied OHL at the designated shaft

The most common radial OHL forces are created by transferring power at a right angle to the reducer's shaft, through an externally mounted power transmission device, such as a belt pulley, chain sprocket, or spur gear.

Included in the overhung load formula is an additional factor that is called the power transmission component factor ( $f_z$ ). The ( $f_z$ ) factor accounts for the extra radial force caused by proper tensioning of belts or chains or the additional forces created by the action of meshing gears.

The following equations are used to calculate the OHL forces generated by a belt pulley, chain sprocket, or spur gear and they also account for the extra radial force caused by proper tensioning of the transmission component. These equations treat the hanging weight of the transmission component as being negligible.

### Variable definitions

$F_{OHL}$	= Calculated shaft overhung load at output
$T_2$ or $T_1$	= Load Torque [lb-in]
$n_2$ or $n_1$	= Shaft speed [rpm]
$P_1$	= Load power at input
$d_{OHL}$	= Pitch diameter of power transmission component [in]
$f_z$	= Power transmission component factor

### Output shaft equations

$$F_{OHL} = \frac{2 \times T_2}{d_{OHL}} \times f_z \text{ (common equation)}$$

$$F_{OHL1} = \frac{2 \times P_1 \times 63025}{n_1 \times d_{OHL}} \times f_z \text{ (alternate equation)}$$



$f_z$  factor table

Transmission Component	Factor $f_z$	Notes
Gear	1.00	17 teeth or less
Gear	1.15	18 teeth or more
Chain Sprocket	1.40	13 teeth or less
Chain Sprocket	1.20	13 to 20 teeth
Chain Sprocket	1.00	20 teeth or more
Timing Belt Pulley	1.50	-
V-Belt Pulley	1.70	-
Flat Belt Pulley	2.50	-

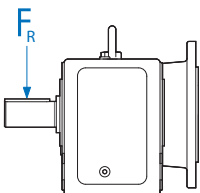

### HARMFUL SITUATION



When gear units are flange mounted opposite shaft, their OHL capacity is greatly reduced compared to the standard catalog ratings. Please consult NORD for details on OHL ratings.





## 2. Determine the permissible shaft OHL rating

### Output shaft OHL rating

Whether considering an integral gearmotor, C-face reducer, or reducer with solid input shaft, the maximum permissible output shaft OHL rating is found in the gearmotor selection tables. Establish the output shaft OHL rating as follows:

- ❶ First, identify the power of the gear unit's driving motor or prime mover.
- ❷ Then, use the gearmotor selection tables to identify the output shaft OHL rating, by selecting the appropriate gear unit type, power, ratio and output speed condition.
- ❸ Next, identify the output shaft OHL rating.

$$F_R = \text{Output shaft OHL rating, at shaft center [lb]}$$

## 3. OHL rating correction – applied load is not at the shaft center or midpoint.

If the OHL force is not applied at the midpoint of the shaft, an overhung load rating correction must be applied to the catalog listed OHL rating. This OHL load correction is evaluated in two steps.

- I. Verify the bearing OHL capacity (Formula I).
- II. Verify the shaft OHL capacity (Formula II).

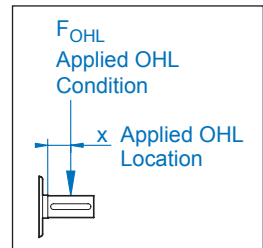

### Overhung Load Variables

- $F_R$  = Output shaft OHL Rating, at shaft center [lb]
- $F_{RX}$  = Standard Bearing Capacity Rating, with OHL applied at output shaft location "x" [lb]
- $F_{RXW}$  = Output shaft OHL Rating, at applied load location "x" with standard bearings [lb]
- x = applied OHL location with respect to shaft shoulder [in]

### Refer to Calculation Table Below

- y = Internal Geometry Factor from table [in]
- z = Factor from table [lb-in]
- c = Internal Geometry Factor from table [lb-in]

Make certain to apply the proper table values for the shaft (output or input) that is being evaluated.

### Formula I – Verifying Bearing Capacity

$$\text{Output shaft (Standard bearings)} F_{RX} = \frac{z}{y+x} \times F_R$$

### Formula II – Calculating the shaft OHL capacity

$$\text{Output shaft (Standard bearings)} F_{RXW} = \frac{c}{f+x}$$

### Foot Mounted

Gearbox type	y in	z in	c lb-in	U in	V In
92072.1 / 93072.1 V	3.58	4.57	1097	0.750	1.50
92172.1 / 93172.1 V	3.76	4.74	1009	0.750	1.50
92372.1 / 93372.1 V	4.37	5.55	1593	1.000	2.13
92672.1 / 93672.1 V	5.12	6.50	2310	1.250	2.75
92772.1 / 93772.1 V	5.83	7.40	2974	1.375	3.00

### Flange Mounted

Gearbox type	y in	z in	c lb-in	U in	V In
92072.1 / 93072.1 VF	4.47	5.45	1097	0.750	1.50
92172.1 / 93172.1 VF	4.92	5.91	1009	0.750	1.50
92372.1 / 93372.1 VF	6.24	7.42	1593	1.000	2.13
92672.1 / 93672.1 VF	6.61	7.99	2310	1.250	2.75
92772.1 / 93772.1 VF	7.52	9.09	2974	1.375	3.00



## IMPORTANT NOTE



Calculations should always be made in accordance with Formula I (bearing capacity) and Formula II (shaft capacity). The corrected OHL rating (for loads not at the shaft midpoint) will always be the lower of the two limiting values based upon direct application of Formula I or Formula II.



## 4. Compare the applied OHL to the OHL rating

To validate the unit selection (assuming negligible thrust loading), the applied OHL condition must be less than the rated OHL capacity as shown below.

### Output Shaft (standard bearings)

$$F_{OHL} < F_R \quad (\text{OHL at shaft center})$$

$$F_{OHL} < F_{RX} \quad (\text{OHL not at shaft center})$$

### Output Shaft (VL bearings)

$$F_{OHL} < F_{RVL} \quad (\text{OHL at shaft center})$$

$$F_{OHL} < F_{RXVL} \quad (\text{OHL not at shaft center})$$

### Output Shaft Comparisons

$$\frac{F_{OHL}}{\quad} < \frac{F_R}{\quad} \quad \text{or} \quad \frac{F_{OHL}}{\quad} < \frac{F_{RX}}{\quad} \quad (\text{Step 3})$$



## 5. Evaluating Thrust Capacity

To validate the unit selection (assuming negligible thrust loading), the applied thrust condition must be less than the rated thrust capacity as shown below.

### Output Shaft

$$F_{THRUST} < F_A$$

The output shaft thrust capacity ( $F_A$ ) can be found in the gearmotor selection tables, adjacent to the OHL ratings.

$$\frac{F_{THRUST}}{\text{(Supplied By Customer)}} < \frac{F_A}{\text{(Gearmotor Selection)}}$$

The output shaft thrust capacity ( $F_A$ ) can be found in the gearmotor selection tables, adjacent to the OHL ratings.



### **IMPORTANT NOTE**



Please contact NORD for more exact examination of the application when both OHL and thrust conditions exist at the same time.



## Computer Program Analysis Capabilities

Upon request, NORD can calculate the bearing service life and check the shaft durability for a specific gear unit type and ratio, if provided with the following:

Type	=	Complete gearmotor or reducer model or type
i	=	Gear ratio
$P_1$	=	Load power at input [Hp]
$n_2$	=	Operating reducer output speed [rpm]
$F_{OHL}$	=	Applied shaft overhung load [lb]
$F_{THRUST}$	=	Applied thrust load condition [lb]
DIR	=	Applied thrust direction (towards or away from gear unit).
x	=	applied OHL location with respect to the shaft shoulder [in]
L10h	=	Desired bearing service life L10h [hours]

When provided the proper information NORD Engineering can provide detailed analysis using a proprietary calculation program.

## Multiple Impeller Mixer

Multiple impeller mixers are good examples where a computer program analysis is encouraged.

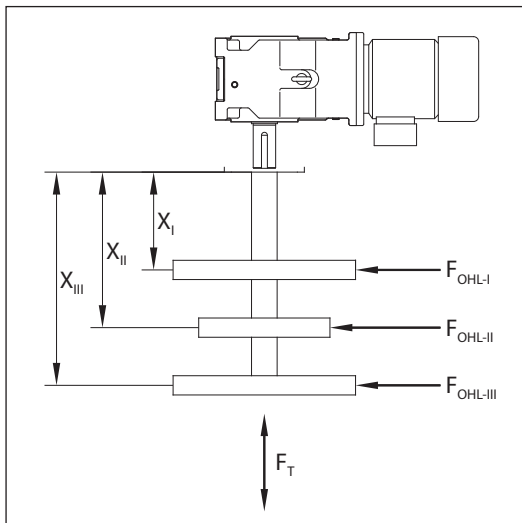

### IMPORTANT NOTE



In agitator or mixer applications, where multiple impellers are mounted to the same mixer shaft, please provide each individual radial load force ( $F_{OHL}$ ) and location distance ( $x$ ).



## Shrink Disc Selection Method

Along with the shrink disc ratings table below, the following procedures are used to verify that a given gear reducer with shrink disc is sized such that the specified shrink disc has adequate capacity to handle the application loads. Consult NORD Engineering when the Shrink Disc connection has an applied bending movement.

### 1. Select the Gear Unit and Shrink Disc

Record the selected gear unit type. Using the ratings table below indicate the shrink disc size or type, and the shrink disc torque rating. Consult NORD if alternate bore sizes are required.

Gear Unit Type \_\_\_\_\_

Shrink Disc Type \_\_\_\_\_

T<sub>SH</sub> (Shrink Disc Torque Rating) \_\_\_\_\_

### 2. Determine the Application Torque

The application torque at the shrink disc can be calculated as follows:

$$T_2 = \frac{P \times 63025}{n_2} \times \eta$$

Where:

T<sub>2</sub> = Application torque [lb - in]

P<sub>n</sub> = Power [hp]

η = Gear reducer efficiency in decimal form.  
(Should use a value of 1.0 unless it is a helical-worm or a compound gear unit).

n<sub>2</sub> = Reducer output speed [rpm]

### 3. Thrust Load

If there is a thrust load (F<sub>T</sub>) present in the system, enter the value below. Otherwise leave blank or enter the value as zero.

F<sub>T</sub> = \_\_\_\_\_ [lb]

### 4. Determine the Resultant Torque

Applications involving simultaneous transmission of torque and additional applied loads in the form of thrust require that a resultant application torque be calculated as follows:

$$T_{2R} = (T_2)^2 + \left(F_T \cdot \frac{d}{2}\right)^2$$

Where:

T<sub>2R</sub> = Resultant torque at reducer output [lb-in]

T<sub>2</sub> = Application torque [lb-in]

F<sub>T</sub> = Thrust Load [lb]

d = Driven shaft diameter / Reducer bore size

### 5. Check the Safety Factor of the Shrink Disc Connection

Calculate the shrink disc safety (f<sub>SD</sub>) with the formula shown and make sure that the specified shrink disc has an appropriate safety factor based upon the application load classification table.

$$f_{SD} = \frac{T_{2S}}{T_{2R}}$$

Where:

f<sub>SD</sub> = Resultant shrink disc design safety factor

T<sub>2S</sub> = Shrink disc Torque Rating [lb-in]

T<sub>2R</sub> = Resultant torque at reducer output [lb-in] (from step 4)

Application Load Classification	Safety Factor
Uniform Load / No Shock Load	1.8 ≤ f <sub>SD</sub> < 2.0
Light to Moderate Shock Load	2.0 ≤ f <sub>SD</sub> < 2.5
Heavy Shock Load	3.0 ≤ f <sub>SD</sub>

### Shrink Disc Ratings

Gear Unit Type	Bore Size	Torque T <sub>2S</sub> [lb-in]	Axial Force F <sub>AS</sub> [lb]	Shrink Disc Type	HHCS Size	Spec.	Screw Qty.	Torque [lb-ft]
SK9X072.1AS	1 in	3,440	6,890	SN25/34 V	M5 X 25	DIN933-10.9	6	5.2
SK9X172.1AS	1 in	4,660	9,310	SN25/35 V	M5 X 25	DIN933-10.9	8	5.2
SK9X372.1AS	1-3/16 in	8,770	14,800	SN30/40 V	M6 x 35	DIN933-10.9	8	8.9
SK9X672.1AS	1-3/8 in	12,600	18,330	SN35/46 V	M6 x 35	DIN933-10.9	10	8.9
SK9X772.1AS	1-1/2 in	19,270	25,690	SN40/55 V	M8 x 40	DIN931-10.9	8	22
SK9X072.1AS	20 mm	2,130	5,420	SN 25/34V	M5 X 25	DIN933-10.9	6	5.2
SK9X072.1AS	25 mm	3,340	6,780	SN25/34 V	M5 X 25	DIN933-10.9	6	5.2
SK9X172.1AS	20 mm	2,890	7,330	SN25/35 V	M5 X 25	DIN933-10.9	8	5.2
SK9X172.1AS	25 mm	4,510	9,170	SN25/35 V	M5 X 25	DIN933-10.9	8	5.2
SK9X372.1AS	25 mm	6,030	12,200	SN30/40 V	M6 x 35	DIN933-10.9	8	8.9
SK9X372.1AS	30 mm	8,670	14,700	SN30/40 V	M6 x 35	DIN933-10.9	8	8.9
SK9X672.1AS	30 mm	9,302	15,750	SN35/46 V	M6 x 35	DIN933-10.9	10	8.9
SK9X672.1AS	35 mm	12,660	18,370	SN35/46 V	M6 x 35	DIN933-10.9	10	8.9
SK9X772.1AS	40 mm	21,240	26,980	SN40/55 V	M8 x 40	DIN931-10.9	8	22
SK9X772.1AS	45 mm	26,890	30,350	SN40/55 V	M8 x 40	DIN933-10.9	8	22



## GRIPMAXX™ Selection Procedure

Along with the GRIPMAXX™ ratings tables on pages 47 - 48, the following procedures are to be used to verify that a given gear reducer with GRIPMAXX™ assembly has adequate capacity and safety factor against slipping given the application load conditions. Consult NORD Engineering when the GRIPMAXX™ connection has an applied bending movement.

INTRODUCTION

### 1. Select the Gear Unit and GRIPMAXX™ Bore Size

Record the gear unit type, ratio and output speed and using the GRIPMAXX™ rating tables on pages 47 - 48 complete the table below. If there is no axial load or thrust load present in the application the axial force rating can be left blank.

Gear Unit Type \_\_\_\_\_  
 Ratio \_\_\_\_\_  
 Power \_\_\_\_\_ hp  
 Output Speed ( $n_2$ ) \_\_\_\_\_ rpm  
 GRIPMAXX™ Bore Size \_\_\_\_\_ in / mm  
 Torque Rating ( $T_{2M}$ ) \_\_\_\_\_ lb-in  
 Axial Force Rating ( $F_{aM}$ ) \_\_\_\_\_ lb

### 2. Determine the Application Torque

The application torque at the GRIPMAXX™ connection shrink disc can be calculated as follows:

$$T_2 = \frac{P \times 63025}{n_2} \times \eta$$

Where:

- $T_2$  = Application torque [lb - in]
- $P_n$  = Power [hp]
- $\eta$  = Gear reducer efficiency in decimal form.  
(Should use a value of 1.0 unless it is a helical-worm or a compound gear unit).
- $n_2$  = Reducer output speed [rpm]

### 3. Calculate the Safety Factor Against Slipping from the Applied Load Torque

Check the safety factor against slipping as follows:

$$S_1 = \frac{T_{2M}}{T_2}$$

Where:

- $S_1$  = Safety factor against slipping (thrust load only)
- $T_{2M}$  = GRIPMAXX™ Torque Rating
- $T_2$  = Applied load torque [lb-in]

If there is no axial force or thrust load present in the application go directly to Step 6.

### 4. Applied Thrust Load / Axial Force

If there is an axial force or thrust load ( $F_T$ ) present in the system record the value below. Otherwise leave blank or indicate as zero.

$$F_T = \text{_____ [lb]}$$

### 5. Calculate the Safety Factor Against Slipping from the Applied Thrust Load

Check to the catalog gearmotor rating tables to make sure the applied thrust load is less than the thrust capacity of the gear unit. Otherwise the gear unit selection is not valid.

Check the safety factor against slipping as follows:

$$S_2 = \frac{F_{aM}}{F_T}$$

Where:

- $S_2$  = Safety factor against slipping (thrust load only)
- $F_{aM}$  = GRIPMAXX™ Axial Force Rating [lb]
- $F_T$  = Applied thrust load axial load force [lb]

### 6. Verify the Safety Factor of the GRIPMAXX™ connection

Calculate the resultant safety factor against slippage ( $S_R$ ) by applying the proper formula or condition.

#### Condition 1 - Applied Torque Only

$$S_R = S_1$$

#### Condition 2 - Applied Torque & Applied Axial/Thrust Load

$$S_R = \sqrt{\frac{(S_1)^2 \cdot (S_2)^2}{(S_1)^2 + (S_2)^2}}$$

Check to make sure that the GRIPMAXX™ connection has and adequate safety factor against slippage.

Application Load Classification	Safety Factor
Uniform Load / No Shock Load	1.8 $S_R < 2.0$
Light to Moderate Shock Load	2.0 $S_R < 2.5$
Heavy Shock Load	3.0 $S_R$





INTRODUCTION

Gear Unit Type	GRIPMAXX™ Ratings			Shrink Disc					Clamp Ring		
	Bushing Bore Size	Torque T <sub>M</sub> [lb-in]	Axial Force F <sub>am</sub> [lb]	Type	HHCS Size	Spec.	Qty.	Torque [ft-lb]	SHCS Size	Spec.	Torque [ft-lb]
SK9X072.1AM	1/2 in	910	3,020	SN25/34V	M5 x 25	DIN 933-10.9	6	5.2	M5 X 20	DIN 912-8.8	4.7
SK9X072.1AM	5/8 in	1,420	3,780	SN25/34V	M5 x 25	DIN 933-10.9	6	5.2	M5 X 20	DIN 912-8.8	4.7
SK9X072.1AM	3/4 in	2,050	4,530	SN25/34V	M5 x 25	DIN 933-10.9	6	5.2	M5 X 20	DIN 912-8.8	4.7
SK9X072.1AM	1 in	3,640	6,040	SN25/34V	M5 x 25	DIN 933-10.9	6	5.2	M5 X 20	DIN 912-8.8	4.7
SK9X172.1AM	5/8 in	2,100	5,720	SN30/42V	M6 x 35	DIN 933-10.9	8	8.9	M6 X 20	DIN 912-8.8	8.1
SK9X172.1AM	3/4 in	3,020	6,870	SN30/42V	M6 x 35	DIN 933-10.9	8	8.9	M6 X 20	DIN 912-8.8	8.1
SK9X172.1AM	1 in	5,380	9,160	SN30/42V	M6 x 35	DIN 933-10.9	8	8.9	M6 X 20	DIN 912-8.8	8.1
SK9X172.1AM	1-1/8 in	6,800	10,300	SN30/42V	M6 x 35	DIN 933-10.9	8	8.9	M6 X 20	DIN 912-8.8	8.1
SK9X172.1AM	1-3/16 in	7,580	10,900	SN30/42V	M6 x 35	DIN 933-10.9	8	8.9	M6 X 20	DIN 912-8.8	8.1
SK9X172.1AM	1-1/4 in	8,400	11,400	SN30/42V	M6 x 35	DIN 933-10.9	8	8.9	M6 X 20	DIN 912-8.8	8.1
SK9X372.1AM	1-1/8 in	7,350	10,300	SN35/49V	M6 x 35	DIN 933-10.9	10	8.9	M8 X 25	DIN 912-8.8	20
SK9X372.1AM	1-3/16 in	8,190	10,900	SN35/49V	M6 x 35	DIN 933-10.9	10	8.9	M8 X 25	DIN 912-8.8	20
SK9X372.1AM	1-1/4 in	9,079	11,400	SN35/49V	M6 x 35	DIN 933-10.9	10	8.9	M8 X 25	DIN 912-8.8	20
SK9X372.1AM	1-3/8 in	10,990	12,600	SN35/49V	M6 x 35	DIN 933-10.9	10	8.9	M8 X 25	DIN 912-8.8	20
SK9X372.1AM	1-7/16 in	12,010	13,100	SN35/49V	M6 x 35	DIN 933-10.9	10	8.9	M8 X 25	DIN 912-8.8	20
SK9X372.1AM	1-1/2 in	13,070	13,700	SN35/49V	M6 x 35	DIN 933-10.9	10	8.9	M8 X 25	DIN 912-8.8	20
SK9X672.1AM	1-1/4 in	13,210	17,200	SN50/62V	M8 x 40	DIN 931-10.9	10	22	M8 X 25	DIN 912-8.8	20
SK9X672.1AM	1-3/8 in	15,990	18,900	SN50/62V	M8 x 40	DIN 931-10.9	10	22	M8 X 25	DIN 912-8.8	20
SK9X672.1AM	1-7/16 in	17,470	19,700	SN50/62V	M8 x 40	DIN 931-10.9	10	22	M8 X 25	DIN 912-8.8	20
SK9X672.1AM	1-1/2 in	19,030	20,600	SN50/62V	M8 x 40	DIN 931-10.9	10	22	M8 X 25	DIN 912-8.8	20
SK9X672.1AM	1-5/8 in	22,330	22,300	SN50/62V	M8 x 40	DIN 931-10.9	10	22	M8 X 25	DIN 912-8.8	20
SK9X672.1AM	1-11/16 in	24,080	23,180	SN50/62V	M8 x 40	DIN 931-10.9	10	22	M8 X 25	DIN 912-8.8	20
SK9X672.1AM	1-3/4 in	25,900	24,040	SN50/62V	M8 x 40	DIN 931-10.9	10	22	M8 X 25	DIN 912-8.8	20
SK9X672.1AM	1-13/16 in	27,780	24,900	SN50/62V	M8 x 40	DIN 931-10.9	10	22	M8 X 25	DIN 912-8.8	20
SK9X672.1AM	1-15/16 in	31,750	26,620	SN50/62V	M8 x 40	DIN 931-10.9	10	22	M8 X 25	DIN 912-8.8	20
SK9X672.1AM	2 in	33,830	27,470	SN50/62V	M8 x 40	DIN 931-10.9	10	22	M8 X 25	DIN 912-8.8	20
SK9X772.1AM	1-1/4 in	13,210	17,200	SN50/62V	M8 x 40	DIN 931-10.9	10	22	M8 X 25	DIN 912-8.8	20
SK9X772.1AM	1-3/8 in	15,990	18,900	SN50/62V	M8 x 40	DIN 931-10.9	10	22	M8 X 25	DIN 912-8.8	20
SK9X772.1AM	1-7/16 in	17,470	19,700	SN50/62V	M8 x 40	DIN 931-10.9	10	22	M8 X 25	DIN 912-8.8	20
SK9X772.1AM	1-1/2 in	19,030	20,600	SN50/62V	M8 x 40	DIN 931-10.9	10	22	M8 X 25	DIN 912-8.8	20
SK9X772.1AM	1-5/8 in	22,330	22,300	SN50/62V	M8 x 40	DIN 931-10.9	10	22	M8 X 25	DIN 912-8.8	20
SK9X772.1AM	1-11/16 in	24,080	23,180	SN50/62V	M8 x 40	DIN 931-10.9	10	22	M8 X 25	DIN 912-8.8	20
SK9X772.1AM	1-3/4 in	25,900	24,040	SN50/62V	M8 x 40	DIN 931-10.9	10	22	M8 X 25	DIN 912-8.8	20
SK9X772.1AM	1-13/16 in	27,780	24,900	SN50/62V	M8 x 40	DIN 931-10.9	10	22	M8 X 25	DIN 912-8.8	20
SK9X772.1AM	1-15/16 in	31,750	26,620	SN50/62V	M8 x 40	DIN 931-10.9	10	22	M8 X 25	DIN 912-8.8	20
SK9X772.1AM	2 in	33,830	27,470	SN50/62V	M8 x 40	DIN 931-10.9	10	22	M8 X 25	DIN 912-8.8	20

# GRIPMAXX™ Ratings (mm)



INTRODUCTION

Gear Unit Type	GRIPMAXX™ Ratings			Shrink Disc					Clamp Ring		
	Bushing Bore Size	Torque $T_M$ [lb-in]	Axial Force $F_{aM}$ [lb]	Type	HHCS Size	Spec.	Qty.	Torque [ft-lb]	SHCS Size	Spec.	Torque [ft-lb]
SK9X072.1AM	20 mm	2,260	4,760	SN25/34V	M5 x 25	DIN 933-10.9	6	5.2	M5 X 20	DIN 912-8.8	4.7
SK9X072.1AM	25 mm	3,530	5,950	SN25/34V	M5 x 25	DIN 933-10.9	6	5.2	M5 X 20	DIN 912-8.8	4.7
SK9X172.1AM	20 mm	3,330	7,210	SN30/42V	M6 x 35	DIN 933-10.9	8	8.9	M6 X 20	DIN 912-8.8	8.1
SK9X172.1AM	25 mm	5,210	9,010	SN30/42V	M6 x 35	DIN 933-10.9	8	8.9	M6 X 20	DIN 912-8.8	8.1
SK9X172.1AM	30 mm	7,500	10,800	SN30/42V	M6 x 35	DIN 933-10.9	8	8.9	M6 X 20	DIN 912-8.8	8.1
SK9X372.1AM	30 mm	8,110	10,800	SN35/49V	M6 x 35	DIN 933-10.9	10	8.9	M8 X 25	DIN 912-8.8	20
SK9X372.1AM	35 mm	11,030	12,600	SN35/49V	M6 x 35	DIN 933-10.9	10	8.9	M8 X 25	DIN 912-8.8	20
SK9X372.1AM	40 mm	14,410	14,400	SN35/49V	M6 x 35	DIN 933-10.9	10	8.9	M8 X 25	DIN 912-8.8	20
SK9X672.1AM	35 mm	16,060	18,900	SN50/62V	M8 x 40	DIN 931-10.9	10	22	M8 X 25	DIN 912-8.8	20
SK9X672.1AM	40 mm	20,970	21,600	SN50/62V	M8 x 40	DIN 931-10.9	10	22	M8 X 25	DIN 912-8.8	20
SK9X672.1AM	45 mm	26,540	24,340	SN50/62V	M8 x 40	DIN 931-10.9	10	22	M8 X 25	DIN 912-8.8	20
SK9X672.1AM	50 mm	32,770	27,040	SN50/62V	M8 x 40	DIN 931-10.9	10	22	M8 X 25	DIN 912-8.8	20
SK9X772.1AM	35 mm	16,060	18,900	SN50/62V	M8 x 40	DIN 931-10.9	10	22	M8 X 25	DIN 912-8.8	20
SK9X772.1AM	40 mm	20,970	21,600	SN50/62V	M8 x 40	DIN 931-10.9	10	22	M8 X 25	DIN 912-8.8	20
SK9X772.1AM	45 mm	26,540	24,340	SN50/62V	M8 x 40	DIN 931-10.9	10	22	M8 X 25	DIN 912-8.8	20
SK9X772.1AM	50 mm	32,770	27,040	SN50/62V	M8 x 40	DIN 931-10.9	10	22	M8 X 25	DIN 912-8.8	20

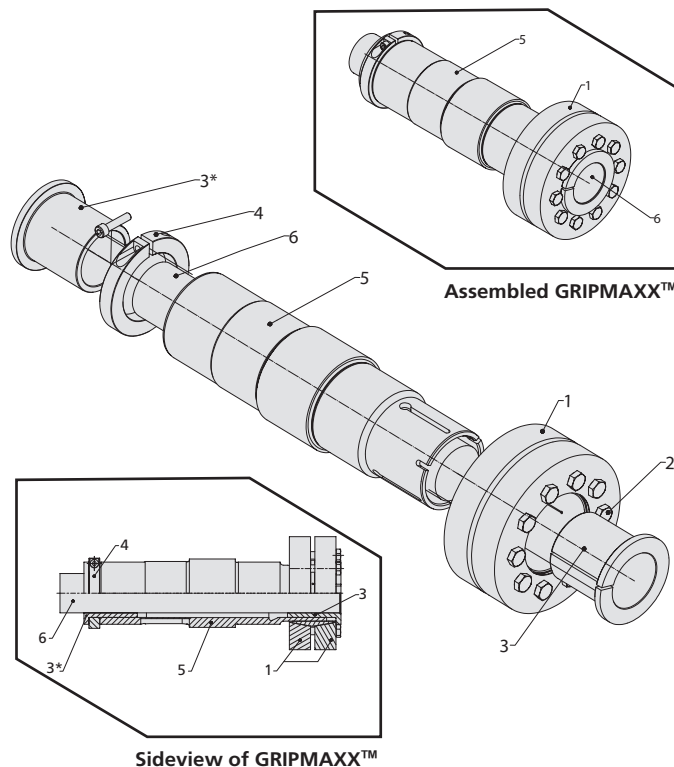

- [1] NORD Shrink Disc
- [2] Locking Screw
- [3] Bushing (Torque Side)
- [3\*] Bushing (Support Side)
- [4] Clamp Ring
- [5] Gear Reducer Hollow Shaft
- [6] Machine Shaft



Solid Shaft Diameter Tolerance [in]		
> 0.375	≤ 1.750	+0.0000 / -0.0005

All Keys and Keyways: Inch - ANSI B17

Solid Shaft Diameter Tolerance [mm]		
> 10	≤ 18	+0.012 / +0.001
> 18	≤ 30	+0.015 / +0.002
> 30	≤ 50	+0.018 / +0.002

All Keys and Keyways: Metric - DIN 6885, class m6

Solid Shaft Drill & Tap Shaft End - Threaded Holes [in]		
> ø 0.500	≤ ø 0.875	1/4-20 x 0.59
> ø 0.875	≤ ø 0.938	5/16-18 x 0.71
> ø 0.938	≤ ø 1.100	3/8-16 x 0.87
> ø 1.100	≤ ø 1.300	1/2-13 x 1.10
> ø 1.300	≤ ø 1.875	5/8-11 x 1.42

Solid Shaft Drill & Tap Shaft End - Threaded Holes [mm]		
> ø 16	≤ ø 21	M6 x 16
> ø 21	≤ ø 24	M8 x 19
> ø 24	≤ ø 30	M10 x 22
> ø 30	≤ ø 38	M12 x 28

Keyed Hollow Bore Tolerances [in]		
> ø 0.4375	≤ ø 1.6250	+0.0010 / -0.0000

Keyed Hollow Bore Tolerances [mm]		
> ø 18	≤ ø 30	+0.021 / -0.000
> ø 30	≤ ø 50	+0.025 / -0.000

Metric hollow bore tolerances per ISO286-2, Class H7

Suggested Solid Shaft Tolerances for Keyed Hollow Bore [in]			
		Uniform Load	Shock Load
> ø 0.4375	≤ ø 0.8750	+0.0000 / -0.0005	+0.0000 / +0.0005
> ø 0.8750	≤ ø 4.5000	+0.0000 / -0.0010	+0.0000 / +0.0010

Suggested Solid Shaft Tolerances for Keyed Hollow Bore [mm]			
		Uniform Load ❶	Shock Load ❷
> ø 18	≤ ø 30	+0.000 / -0.013	+0.015 / +0.002
> ø 30	≤ ø 50	+0.000 / -0.016	+0.018 / +0.002

❶ Uniform load: Mating shaft diameter tolerance per ISO286-2, class h6

❷ Shock load: Mating shaft diameter tolerance per ISO286-2, class k6

Customer Shaft Diameter Tolerance w/ Shrink Disk [in]			
Shaft Diameter ❶		Shaft Tolerance ❷	Bore Tolerance ❸
≥ ø 0.7500	≤ ø 1.1250	+0.0000 / -0.0005	+0.0008 / -0.0000
≥ ø 1.1250	≤ ø 1.9375	+0.0000 / -0.0006	+0.0009 / -0.0000

❶ Solid Shaft finish to be 125 micro inches (3.2mm) or smoother

❷ Inch Shaft Tolerances per ISO286-2, Class h6

❸ Inch hollow bore tolerances per ISO286-2, Class H7

Customer Shaft Diameter Tolerance w/ Shrink Disk [mm]			
Shaft Diameter ❶		Shaft Tolerance ❷	Bore Tolerance ❸
> ø 18	≤ ø 30	+0.000 / -0.013	+0.021 / -0.000
> ø 30	≤ ø 50	+0.000 / -0.016	+0.025 / -0.000

❶ Solid Shaft finish to be 125 micro inches (3.2mm) or smoother

❷ Inch Shaft Tolerances per ISO286-2, Class h6

❸ Inch hollow bore tolerances per ISO286-2, Class H7

Customer Shaft Diameter Tolerance w/GRIPMAXX [in]		
Shaft Diameter ❶		Shaft Tolerance ❷
ø 0.7500	≤ ø 1.0625	- 0.005
ø 1.1250	≤ ø 1.9375	- 0.006

❶ Solid Shaft finish to be 125 micro inches (3.2mm) or smoother

❷ Inch Shaft Tolerances per ISO286-2, Class h11

Customer Shaft Diameter Tolerance w/GRIPMAXX [mm]		
Shaft Diameter ❶		Shaft Tolerance ❷
ø 18	≤ ø 30	- 0.13
ø 30	≤ ø 50	- 0.16

❶ Solid Shaft finish to be 125 micro inches (3.2mm) or smoother

❷ Inch Shaft Tolerances per ISO286-2, Class h11

Flange Pilot (AK or AK1) Tolerance [in]			
Flange Pilot Diameter		Pilot Tolerance	Fit Class ❶
> ø 1.969	≤ ø 3.150	+0.0005 / -0.0003	j6
> ø 3.150	≤ ø 4.724	+0.0005 / -0.0004	j6
> ø 4.724	≤ ø 7.087	+0.0006 / -0.0004	j6
> ø 7.087	≤ ø 9.055	+0.0006 / -0.0005	j6
> ø 9.055	≤ ø 9.843	+0.0000 / -0.0011	h6

❶ Inch Pilot Tolerances per ISO286-2

Flange Pilot (AK or AK1) Tolerance [mm]			
Flange Pilot Diameter		Pilot Tolerance	Fit Class ❶
> ø 80	≤ ø 120	+0.013 / -0.009	j6
> ø 120	≤ ø 180	+0.014 / -0.011	j6
> ø 180	≤ ø 230	+0.016 / -0.013	j6
> ø 230	≤ ø 250	+0.000 / -0.029	h6

❶ Metric Pilot Tolerances per ISO286-2

Casting Surfaces may differ slightly (approximately 0.125 inches or 3.2mm) from the specified nominal dimensions as a result of the manufacturing process

# Engineering Conversions & Formulas



## Metric ⇒ Inch

Multiply	By	To Obtain
Gram [g]	x 0.0353	= oz
Kilogram [kg]	x 2.205	= lb
Newton [N]	x 0.2248	= lb
Newton meter [Nm]	x 8.851	= lb-in
Newton meter [Nm]	x 0.7375	= lb-ft
Inertia [kgm <sup>2</sup> ]	x 23.75	= lb-ft <sup>2</sup>
Kilowatt [kW]	x 1.341	= hp
Meter [m]	x 39.4	= in
Meter [m]	x 3.281	= ft
Meter [m]	x 1.094	= yd
Millimeter [mm]	x 0.0391	= in
Centimeter [cm]	x 0.394	= in
Cubic Centimeter [cm <sup>3</sup> ]	x 0.061	= in <sup>3</sup>
Liter [l]	x 61.023	= in <sup>3</sup>
Liter [l]	x 1.057	= qt
Liter [l]	x 0.2642	= gal

## Inch ⇒ Metric

Multiply	By	To Obtain
Ounce [oz]	x 28.35	= g
Pound [lb]	x 0.454	= kg
Ounce [oz]	x 0.028	= kg
Pound [lb]	x 4.448	= N
Pound-Inch [lb-in]	x 0.113	= Nm
Pound Feet [lb-ft]	x 1.3558	= Nm
Pound Feet Squared [lb-ft <sup>2</sup> ]	x 0.0421	= kgm <sup>2</sup>
Horsepower [hp]	x 0.746	= kW
Feet [ft]	x 0.3048	= m
Yard [yd]	x 0.9144	= m
Inch [in]	x 25.4	= mm
Inch [in]	x 2.54	= cm
Inch [in]	x 0.0254	= m
Cubic Inch [in <sup>3</sup> ]	x 16.39	= cm <sup>3</sup>
Cubic Inch [in <sup>3</sup> ]	x 0.016	= liters
Gallon [gal]	x 3.785	= liters

## Temperature

°F	=	1.8 °C + 32
°C	=	0.5555 x (°F - 32)
°C	=	°K - 273.16

## Linear Velocity

Miles per Hour [mph]	x 88	= ft/min [fpm]
Miles per Hour [mph]	x 1.4677	= ft/sec [fps]
Feet per Minute [fpm]	x 0.3048	= m/min
Feet per Minute [fpm]	x 0.00508	= m/sec
Meter per Minute [m/min]	x 3.2808	= ft/min [fpm]
Meter per Second [m/sec]	x 196.85	= ft/min [fpm]

## Power

$$hp = \frac{\text{Torque (lb-in)} \times \text{rpm}}{63025}$$

$$hp = \frac{\text{Torque (lb-ft)} \times \text{rpm}}{5252}$$

$$hp_{\text{(Lift)}} = \frac{\text{Wgt (lb)} \times \text{fpm}}{33000 \times \text{Efficiency}}$$

$$hp_{\text{(Slide)}} = \frac{\text{Wgt (lb)} \times \mu \times \text{fpm}}{33000 \times \text{Efficiency}}$$

## Torque

$$T_{\text{(lb-in)}} = \frac{hp \times 63025}{\text{rpm}}$$

$$T_{\text{(lb-ft)}} = \frac{hp \times 5252}{\text{rpm}}$$

## Electric Motor 3-phase

$$hp_{\text{(3ph-motor)}} = \frac{1.732 \times V \times I \times \text{PF} \times \text{Efficiency}}{746}$$

## Linear & Rotational Speed

$$\text{fpm} = 0.2618 \times \text{Dia}_{\text{(in)}} \times \text{rpm}$$

$$\text{rpm} = \frac{\text{fpm} \times 3.820}{\text{Dia}_{\text{(in)}}}$$

## Metric M Threads

For metric "M" threads, it is customary to omit the thread pitch for course threads. For example, if a thread is called out as an M8 with no pitch shown, it is automatically a course pitch thread.

Course threads and pitch
M6 x 1
M8 x 1.25
M10 x 1.5
M12 x 1.75
M16 x 2
M20 x 2.5
M24 x 3



## Mass Acceleration Service Factor

The mass acceleration factor ( $m_{af}$ ) uses a ratio of the load inertia to motor inertia. This method of service factor calculation can be used for both gearmotors and speed reducers and is valid for helical gear units.

Short-term and infrequent torque impulses significantly influence the load and selection of a gear unit. The gear unit service factor,  $f_B$ , takes this and other affects on the gear unit into account.

The mass acceleration factor ( $m_{af}$ ) represents the relationship between external low-speed output side and high-speed input side masses. The mass acceleration factor significantly influences the level of torque impulses in the gear unit upon start-up and braking procedures, and upon vibration. The external mass moments of inertia also include the load, such as the material transported on conveyor belts. We ask you to consult with NORD if the  $m_{af} > 10$ , if there is a large play in transfer elements, vibration in the system, uncertainty regarding the load classification, or you are in doubt.

For applications with relatively high external mass moments of inertia,  $m_{af} > 2$  (i.e. travel drives, slewing gears, rotary tables, gear drives, agitators, and surface aerators), we recommend breaking torque that does not exceed 1.2 times the rated motor torque. If a higher breaking torque is to be used, this must be considered when selecting the gear unit.

1. Calculate mass acceleration factor:

$$m_{af} = \frac{J_{load}}{J_{motor}} \times \left( \frac{1}{\text{reducer ratio}} \right)^2$$

$J_{load}$  = External load inertia including all components of the system outside of the reducer  
 $J_{motor}$  = Motor inertia.

For NORD motors see pages 168 - 177

**If  $m_{af} \leq 0.25$  use curve A (uniform operation)**

Light conveyor screws, fans, assembly lines, light conveyor belts, small agitators, elevators, cleaning machines, filling machines, inspection machines, belt conveyors.

**If  $0.25 < m_{af} \leq 3.00$  use curve B (moderate shocks)**

Coilers, feed-mechanism drivers for woodworking machines, dumbwaiters, balancing machines, thread cutting machines, medium-sized agitators and mixers, heavy conveyor belts, winches, sliding doors, manure scrapers, packing machines, concrete mixers, overhead crane traveling mechanisms, mills, bending machines, gear pumps.

**If  $3.01 \leq m_{af} < 10.00$  use curve C (heavy shocks)**

Heavy mixers, shears, presses, centrifuges, rolling stands, heavy winches and lifts, grinding mills, stone crushers, bucket elevators, punching machines, hammer mills, eccentric presses, folding machines, roller tables, tumbling barrels, vibrators, shredders.

- Determine the cycles/hour. A cycle is a start or hard stop, where a hard stop decelerates the motion of the system when a mechanical brake is activated.
- Determine the run time in hours/day.
- Using the chart; locate the cycles/hour on the horizontal axis and move vertically up to intersect curve A, B, or C based on the  $m_{af}$ . From the intersection point, move horizontally left to the service factor  $f_B$ , which is based on the run time in hours/day.

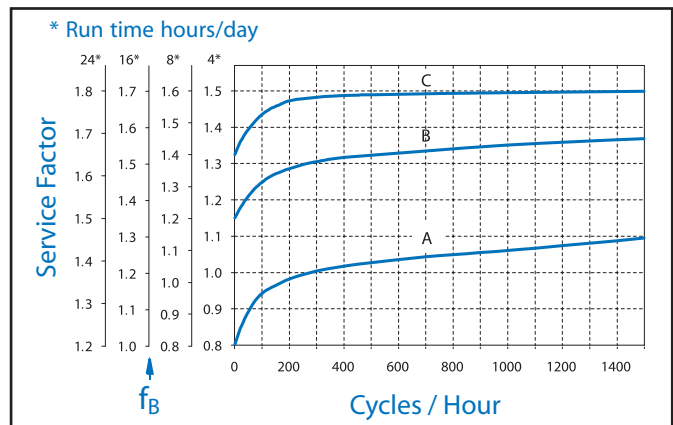

### EXAMPLE for gearmotor:

A smooth running conveyor operates 24 hours/day with 500 cycles/hour. The calculated  $m_{af} = 0.16$ , therefore use curve A for this type of application.

From the chart, find 500 cycles/hour and follow the axis vertically up until you intersect curve A. From the intersection point, move horizontally left to find the service factor  $f_B = 1.4$  based on 24 hours/day operation. Consult the selection pages of the catalog to find a gearmotor with a service factor  $f_B = 1.4$  or greater.





## AGMA Selection Method

### Gearmotors

Before a gearmotor is selected, an application class number must be determined. Since application classification represents the normal relationship between gear design power rating and the maximum potential transmitted power, it is suggested that the application class number be applied to the nameplate rating of the electric motor. The application class numbers are I, II, and III.

Their relationship to service factor is:

Class Numbers	$f_B$
I	1.0 - 1.39
II	1.4 - 1.99
III	$\geq 2.0$

Application class numbers may be selected from the table. Some operational characteristics that affect an application's classification are:

- **Starting conditions:** Starting conditions where peak loads exceed 200 percent of rated load, applications with frequent starts and stops and reversing applications require special analysis. Rated load is defined as the unit rating with an application class number of I (1.0 - 1.39 service factor).
- **Overloads:** Loads in excess of the rated load are considered overloads. Overload can be of momentary duration, periodic, quasi-steady state, or vibratory in nature. The magnitude and the number of stress cycles require special analysis to prevent low cycle fatigue or yield stress failure. Applications with high torque motors, motors for intermittent operation and applications where extreme repetitive shock occurs or where high-energy loads must be absorbed as when stalling require special consideration.
- **Brake equipped applications:** When a gear drive is equipped with a brake that is used to decelerate the motion of the system, select the drive based on the brake rating or the equivalent power, which ever is greater. If the brake is located on the output shaft of the gear drive, special analysis is required.
- **Reliability and life requirement:** Applications requiring a high degree of reliability or unusually long life should be given careful consideration by the user and NORD GEAR before assigning an application class number. High reliability and life should be addressed by using an increased safety factor agreed to between NORD and the purchaser.

Synchronous motors, certain types of high torque induction motors and generator drives require special analysis.

- Synchronous motors have high transient torque during starting and restarting after they trip out momentarily.
- Induction motors of special high slip design can produce extremely high starting torque. High torque loads are produced when the motor trips out for a very short time and then the trip re-closes.
- Generators have extremely high loads when they are out of phase with the main system and when there are across the line short circuits.

Adjustments to the gear drive selection may be necessary when one or more of the following exist:

- Extremes of temperature and environment.
- Lubrication. Any lubricant not in accordance with NORD's recommendations.
- Misalignment and distortions due to inadequate foundations.
- Reversing applications.
- High-risk applications involving human safety.

The purpose of the AGMA Service Class table is to provide a guide in the selection and application of gear drives designed and rated in accordance with AGMA Standard 6009.

The service class tables have been developed from the experience of manufacturers and users of gear drives for use in common applications and has been found to be generally satisfactory for the listed industries when gears are applied using AGMA standards. It is recommended that the user and NORD Gear agree upon class numbers for special applications when variations of the table may be required.



Application	Load Duration		
	Up to 3 hrs per day	3-10 hrs per day	Over 10 hrs per day
AGITATORS (mixers)			
Pure Liquids	I	I	II
Liquids and Solids	I	II	II
Liquids – Variable Density	I	II	II
BLOWERS			
Centrifugal	I	I	II
Lobe	I	II	II
Vane	I	II	II
BREWING AND DISTILLING			
Bottling Machinery	I	I	II
Brew Kettles – Continuous Duty	II	II	II
Cookers – Continuous Duty	II	II	II
Mash Tubs – Continuous Duty	II	II	II
Scale Hopper – Frequent Starts	II	II	II
CAN FILLING MACHINES	I	I	II
CAR DUMPERS	II	III	III
CAR PULLERS	I	II	II
CLARIFIERS	I	I	II
CLASSIFIERS	I	II	II
CLAY WORKING MACHINERY			
Brick Press	II	III	III
Briquette Machine	II	III	III
Pug Mill	I	II	II
COMPACTORS	III	III	III
COMPRESSORS			
Centrifugal	I	I	II
Lobe	I	II	II
Reciprocating, Multi-Cylinder	II	II	III
Reciprocating, Single-Cylinder	III	III	III
CONVEYORS – GENERAL PURPOSE			
Includes Apron, Assemble, Belt, Bucket, Chain, Flight, Oven & Screw Uniformly loaded or Fed	I	I	II
Heavy Duty – Not Uniformly Fed	I	II	II
Severe Duty – Reciprocating or Shaker	II	III	III
CRANES			
Main Hoist			
Medium Duty	II	II	II
Heavy Duty	III	III	III
Reversing	II	II	II
Skip Hoist	II	II	II
Trolley Drive	II	II	II
Bridge Drive	II	II	II
CRUSHER			
Stone or Ore	III	III	III
DREDGES			
Cable Reels	II	II	II
Conveyors	II	II	II
Cutter Head Dives	III	III	III
Pumps	III	III	III
Screen Drives	III	III	III
Stackers	II	II	II
Winches	II	II	II

Application	Load Duration		
	Up to 3 hrs per day	3-10 hrs per day	Over 10 hrs per day
ELEVATORS			
Bucket	I	II	II
Centrifugal Discharge	I	I	II
Escalators	I	I	II
Freight	I	II	II
Gravity Discharge	I	I	II
EXTRUDERS			
General	II	II	II
Plastics			
Variable Speed Drive	III	III	III
Fixed Speed Drive	III	III	III
Rubber			
Continuous Screw Operation	III	III	III
Intermittent Screw Operation	III	III	III
FANS			
Centrifugal	I	I	II
Cooling Towers	III	III	III
Forced Draft	II	II	II
Induced Draft	II	II	II
Industrial & Mine	II	II	II
FEEDERS			
Apron	I	II	II
Belt	I	II	II
Disc	I	I	II
Reciprocating	II	III	III
Screw	I	II	II
FOOD INDUSTRY			
Cereal Cooker	I	I	II
Dough Mixer	II	II	II
Meat Grinders	II	II	II
Slicers	I	II	II
GENERATORS AND EXCITERS	II	II	II
HAMMER MILLS	III	III	III
HOISTS			
Heavy Duty	III	III	III
Medium Duty	II	II	II
Skip Hoist	II	II	II
LAUNDRY TUMBLERS	II	II	II
LAUNDRY WASHERS	II	II	III

INTRODUCTION



Application	Load Duration			Application	Load Duration		
	Up to 3 hrs per day	3-10 hrs per day	Over 10 hrs per day		Up to 3 hrs per day	3-10 hrs per day	Over 10 hrs per day
<b>LUMBER INDUSTRY</b>				<b>MILLS, ROTARY TYPE</b>			
Barkers				Ball & Rod			
Spindle Feed	II	II	II	Spur Ring Gear	III	III	III
Main Drive	III	III	III	Helical Ring Gear	II	II	II
Conveyors				Direct Connected	III	III	III
Burner	II	II	II	Cement Kilns	II	II	II
Main or Heavy Duty	II	II	II	Dryers & Coolers	II	II	II
Main log	III	III	III	<b>PAPER MILLS<sup>1)</sup></b>			
Re-saw, Merry-Go-Round	II	II	II	Agitator (Mixer)	II	II	II
Slab	III	III	III	Agitator for Pure liquors	II	II	II
Transfer	II	II	II	Barking Drums	III	III	III
Chains				Barkers – Mechanical	III	III	III
Floor	II	II	II	Beater	II	II	II
Green	II	II	III	Breaker Stack	II	II	II
Cut-Off Saws				Calender <sup>2)</sup>	II	II	II
Chain	II	II	III	Chipper	III	III	III
Drag	II	II	III	Chip Feeder	II	II	II
Debarking Drums	III	III	III	Coating Rolls	II	II	II
Feeds				Conveyors			
Edger	II	II	II	Chip, Bark, Chemical	II	II	II
Gang	II	III	III	log (including Slab)	III	III	III
Trimmer	II	II	II	Couch Rolls	II	II	II
Long Deck	III	III	III	Cutter	III	III	III
Log Hauls – Incline – Well Type	III	III	III	Cylinder Molds	II	II	II
Log Turning Devices	III	III	III	Dryers <sup>2)</sup>			
Planer Feed	II	II	II	Paper Machine	II	II	II
Planer Tilting Hoists	II	II	II	Conveyor Type	II	II	II
Rolls – live-off brg. – Roll Cases	III	III	III	Embosser	II	II	II
Sorting Table	II	II	II	Extruder	II	II	II
Tipple Hoist	II	II	II	Fourdrinier Rolls (Includes lump Breaker, Dandy Roll, Wire Turning, and Return Rolls)	II	II	II
Transfers				Jordan	II	II	II
Chain	II	II	III	Kiln Drive	II	II	II
Craneway	II	II	III	Mt. Hope Roll	II	II	II
Tray Drives	II	II	II	Paper Rolls	II	II	II
Veneer Lathe Drives	II	II	II	Platter	II	II	II
<b>METAL MILLS</b>				Presses – Felt & Suction	II	II	II
Draw Bench Carriage & Main Drive	II	II	II	Pulper	III	III	III
Runout Table				Pumps – Vacuum	II	II	II
Non-reversing				Reel (Surface Type)	II	II	II
Group Drives	II	II	II	Screens			
Individual Drives	III	III	III	Chip	II	II	II
Reversing	III	III	III	Rotary	II	II	II
Slab Pushers	II	II	II	Vibrating	III	III	III
Shears	III	III	III	Size Press	II	II	II
Wire drawing	II	II	II	Supercalendar <sup>3)</sup>	II	II	II
Wire Winding Machine	II	II	II	Thickener (AC Motor)	II	II	II
<b>METAL STRIP PROCESSING MACHINERY</b>				Thickener (DC Motor)	II	II	II
Bridles	II	II	II	Washer (AC Motor)	II	II	II
Coilers & Uncoilers	I	I	II	Washer (DC Motor)	II	II	II
Edge Trimmers	I	II	II	Wind and Unwind Stand	I	I	I
Flatteners	II	II	II	Winders (Surface Type)	II	II	II
Loopers (Accumulators)	I	I	I	Yankee Dryers <sup>2)</sup>	II	II	II
Pinch Rolls	II	II	I				
Scrap Choppers	II	II	II				
Shears	III	III	III				
Slitters	I	II	II				



INTRODUCTION

Application	Load Duration		
	Up to 3 hrs per day	3-10 hrs per day	Over 10 hrs per day
<b>PLASTICS INDUSTRY – PRIMARY PROCESSING</b>			
Intensive Internal Mixers			
Batch Mixers	III	III	III
Continuous Mixers	II	II	II
Batch Drop Mill – 2 smooth rolls	II	II	II
Continuous Feed, Holding & Blend Mill Calendars	II	II	II
<b>PLASTICS INDUSTRY – SECONDARY PROCESSING</b>			
Blow Molders	II	II	II
Coating	II	II	II
Film	II	II	II
Pipe	II	II	II
Pre-Plasticizers	II	II	II
Rods	II	II	II
Sheet	II	II	II
Tubing	II	II	II
<b>PULLERS – BARGE HAUL</b>	II	II	II
<b>PUMPS</b>			
Centrifugal	I	I	II
Proportioning	II	II	II
Reciprocating			
Single Acting, 3 or more cylinders	II	II	II
Double Acting, 2 or more cylinders	II	II	II
Rotary			
Gear Type	I	I	II
Lobe	I	I	II
Vane	I	I	II
<b>RUBBER INDUSTRY</b>			
Intensive Internal Mixers			
Batch Mixers	III	III	III
Continuous Mixers	II	II	II
Mixing Mill			
2 smooth rolls	II	II	II
1 or 2 corrugated rolls	III	III	III
Batch Drop Mill – 2 smooth rolls	II	II	II
Cracker Warmer – 2 roll, 1 corrugated roll	III	III	III
Cracker – 2 corrugated rolls	III	III	III
Holding, Feed & Blend Mill – 2 rolls	II	II	II
Refiner – 2 rolls	II	II	II
Calendars	II	II	II
<b>SAND MULLER</b>	II	II	II
<b>SEWAGE DISPOSAL EQUIPMENT</b>			
Bar Screens	II	II	II
Chemical Feeders	II	II	II
Dewatering Screens	II	II	II
Scum Breakers	II	II	II
Slow or Rapid Mixers	II	II	II
Sludge Collectors	II	II	II
Thickener	II	II	II
Vacuum Filters	II	II	II

Application	Load Duration		
	Up to 3 hrs per day	3-10 hrs per day	Over 10 hrs per day
<b>SCREENS</b>			
Air Washing	I	I	II
Rotary – Stone or Gravel	II	II	II
Traveling Water Intake I	I	I	I
<b>SCREW CONVEYORS</b>			
Uniformly loaded or Fed	I	I	II
Heavy Duty	I	II	II
<b>SUGAR INDUSTRY</b>			
Beet Slicer	III	III	III
Cane Knives	II	II	II
Crushers	II	II	II
Mills (low speed end)	III	III	III
<b>TEXTILE INDUSTRY</b>			
Batchers	II	II	II
Calendars	II	II	II
Cards	II	II	II
Dry Cans	II	II	II
Dyeing Machinery	II	II	II
Looms	II	II	II
Mangles	II	II	II
Nappers	II	II	II
Pads	II	II	II
Siashers	II	II	II
Soapers	II	II	II
Spinners	II	II	II
Tenter Frames	II	II	II
Washers	II	II	II
Winders	II	II	II

**Notes to GEARMOTOR SERVICE FACTOR table:**

- 1) The class numbers listed for paper mill applications are consistent with those shown in TAPPI (Technical Association of Pulp and Paper Industry) Technical Information Sheet 0406-18 1967, Service Factors for Gears on major Equipment in the Paper and Pulp Industry.
- 2) Anti-friction bearings only.
- 3) A Class Number of I may be applied at base speed of a supercalendar operating over a speed range of part-range constant horsepower and part-range constant torque where the constant horsepower speed range is greater than 1.5 to 1. A Class Number of II is applicable to supercalendars operating over the entire speed range at constant torque or where the constant horsepower speed range is less than 1.5 to 1.



## Speed Reducers

Before an enclosed speed reducer or increaser can be selected for any application, an equivalent unit power rating (service factor = 1.0) must be determined. This is done by multiplying the specified power by the service factor. Since the service factor represents the normal relationship between the gear unit rating and the required application power, it is suggested that the service factor be applied to the nameplate rating of the prime mover or driven machine rating, as applicable.

NORD GEAR and the user must agree upon which power, prime mover rating or driven machine requirements, should dictate the selection of the gear drive. It is necessary that the gear drive selected have a rated unit capacity equal to or in excess of this "equivalent unit power rating".

All service factors listed are 1.0 or greater. Service factors less than 1.0 can be used in some applications when specified by the user and agreed to by NORD GEAR.

The REDUCER SERVICE FACTOR table should be used with caution, since much higher values have occurred in some applications. Values as high as ten have been used. On some applications up to six times nominal torque can occur, such as: Turbine/Generator drives, Heavy Plate and Billet rolling mills.

It has been developed from the experience of manufacturers and users of gear drives for use in common applications. It is suggested that service factors for special applications be agreed upon by the user and NORD GEAR when variations of the values in the table may be required.

Service factors shown are for reducers driven by motors (electric or hydraulic) and turbines (steam or gas) according to AGMA 6010. When the driver is a single cylinder or multi-cylinder engine, the service factors from the table must be modified for the appropriate type of prime mover.

As an example, if the application is a centrifugal blower, the service factor from the REDUCER SERVICE FACTOR table is 1.25 for a motor or turbine. The CONVERSION TABLE changes this value to 1.75 for a single cylinder engine and 1.50 for a multi-cylinder engine.

**CAUTION:** Any user of enclosed gear drives should make sure that the latest available information affecting the selection of a gear drive is used. When better load intensity data is available on the driving or driven equipment, this should be considered when a service factor is selected.

### Conversion Table

Electric Motor, Steam & Gas Turbines, Hydraulics	Single-Cylinder Engines	Multi-Cylinder Engines
1.00	1.50	1.25
1.25	1.75	1.50
1.50	2.0	1.75
1.75	2.25	2.00
2.00	2.50	2.25
2.25	2.75	2.50
2.50	3.00	2.75
2.75	3.25	3.00
3.00	3.50	3.25

Application	Load Duration		
	Up to 3 hrs per day	3-10 hrs per day	Over 10 hrs per day
AGITATORS (mixers)			
Pure Liquids	1.00	1.00	1.25
Liquids and Solids	1.00	1.25	1.50
Liquids – Variable Density	1.00	1.25	1.50
BLOWERS			
Centrifugal	1.00	1.25	1.50
Lobe	1.00	1.25	1.50
Vane	1.00	1.00	1.25
BREWING AND DISTILLING			
Bottling Machinery	1.00	1.00	1.25
Brew Kettles – Continuous Duty	1.00	1.00	1.25
Cookers – Continuous Duty	1.00	1.00	1.25
Mash Tubs – Continuous Duty	1.00	1.00	1.25
Scale Hopper – Frequent Starts	1.00	1.25	1.50
CAN FILLING MACHINES	1.00	1.00	1.25
CAR DUMPERS	1.25	1.50	1.75
CAR PULLERS	1.00	1.25	1.50
CLARIFIERS	1.00	1.00	1.25
CLASSIFIERS	1.00	1.25	1.50
CLAY WORKING MACHINERY			
Brick Press	1.25	1.50	1.75
Briquette Machine	1.25	1.50	1.75
Pug Mill	1.00	1.25	1.50
COMPACTORS	1.50	1.75	2.00
COMPRESSORS			
Centrifugal	1.00	1.00	1.25
Lobe	1.00	1.25	1.50
Reciprocating, Multi-Cylinder	1.00	1.25	1.50
Reciprocating, Single-Cylinder	1.25	1.50	1.75
CONVEYORS – GENERAL PURPOSE			
Uniformly loaded or fed	1.00	1.00	1.25
Not uniformly fed	1.00	1.25	1.50
Reciprocating or shaker	1.25	1.50	1.75
CRANES			
Dry dock			
Main hoist	1.25	1.50	1.75
Auxilliary hoist	1.25	1.50	1.75
Boom hoist	1.25	1.50	1.75
Slewing drive	1.25	1.50	1.75
Traction drive	1.50	1.50	1.50
Industrial Duty			
Main hoist	1.00	1.25	1.50
CRUSHER			
Stone or ore	1.50	1.75	2.00





Application	Load Duration		
	Up to 3 hrs per day	3-10 hrs per day	Over 10 hrs per day
<b>DREDGES</b>			
Cable reels	1.00	1.25	1.50
Conveyors	1.00	1.25	1.50
Cutter Head Dives	1.25	1.50	1.75
Pumps	1.00	1.25	1.50
Screen Drives	1.25	1.50	1.75
Stackers	1.00	1.25	1.50
Winches	1.00	1.25	1.50
<b>ELEVATORS</b>			
Bucket	1.00	1.25	1.50
Centrifugal Discharge	1.00	1.00	1.25
Gravity Discharge	1.00	1.00	1.25
<b>EXTRUDERS</b>			
General	1.25	1.25	1.25
Plastics			
Variable Speed Drive	1.50	1.50	1.50
Fixed Speed Drive	1.75	1.75	1.75
Rubber			
Continuous Screw Operation	1.50	1.50	1.50
Intermittent Screw Operation	1.75	1.75	1.75
<b>FANS</b>			
Centrifugal	1.00	1.00	1.25
Forced Draft	1.25	1.25	1.25
Induced Draft	1.00	1.25	1.50
Industrial & Mine	1.00	1.25	1.50
<b>FEEDERS</b>			
Apron	1.00	1.25	1.50
Belt	1.00	1.25	1.50
Disc	1.00	1.00	1.25
Reciprocating	1.25	1.50	1.75
Screw	1.00	1.25	1.50
<b>FOOD INDUSTRY</b>			
Cereal Cooker	1.00	1.00	1.25
Dough Mixer	1.00	1.25	1.50
Meat Grinders	1.00	1.25	1.50
Slicers	1.00	1.25	1.50
<b>GENERATORS AND EXCITERS</b>	1.00	1.00	1.25
<b>HAMMER MILLS</b>	1.50	1.50	1.75
<b>HOISTS</b>			
Heavy Duty	1.25	1.50	1.75
Medium Duty	1.00	1.25	1.50
Skip Hoist	1.00	1.25	1.50
<b>LAUNDRY TUMBLERS</b>	1.00	1.25	1.50
<b>LAUNDRY WASHERS</b>	1.25	1.25	1.50

Application	Load Duration		
	Up to 3 hrs per day	3-10 hrs per day	Over 10 hrs per day
<b>LUMBER INDUSTRY</b>			
Barkers	1.25	1.25	1.50
Spindle Feed	1.50	1.50	1.50
Main Drive	1.25	1.25	1.50
Conveyors			
Burner	1.25	1.25	1.50
Main or Heavy Duty	1.50	1.50	1.50
Main log	1.50	1.50	1.75
Re-saw, Merry-Go-Round	1.25	1.25	1.50
Slab	1.50	1.50	1.75
Transfer	1.25	1.25	1.50
Chains			
Floor	1.50	1.50	1.50
Green	1.50	1.50	1.50
Cut-Off Saws			
Chain	1.50	1.50	1.50
Drag	1.50	1.50	1.50
Debarking Drums	1.50	1.50	1.75
Feeds			
Edger	1.25	1.25	1.50
Gang	1.50	1.50	1.50
Trimmer	1.25	1.25	1.50
Long Deck	1.50	1.50	1.50
Log Hauls – Incline – Well Type	1.50	1.50	1.50
Log Turning Devices	1.50	1.50	1.50
Planer Feed	1.25	1.25	1.50
Planer Tilting Hoists	1.50	1.50	1.50
Rolls – live-off brg. – Roll Cases	1.50	1.50	1.50
Sorting Table	1.25	1.50	1.50
Tipple Hoist	1.25	1.25	1.50
Transfers			
Chain	1.50	1.50	1.50
Causeway	1.50	1.50	1.50
Tray Drives	1.25	1.25	1.50
<b>METAL MILLS</b>			
Draw Bench Carriage & Main Drive	1.00	1.25	1.50
Runout Table			
Non-reversing			
Group Drives	1.00	1.25	1.50
Individual Drives	1.50	1.50	1.75
Reversing	1.50	1.50	1.75
Slab Pushers	1.25	1.25	1.50
Shears	1.50	1.50	1.75
Wire drawing	1.00	1.25	1.50
Wire Winding Machine	1.00	1.25	1.50





Application	Load Duration			Application	Load Duration		
	Up to 3 hrs per day	3-10 hrs per day	Over 10 hrs per day		Up to 3 hrs per day	3-10 hrs per day	Over 10 hrs per day
<b>METAL STRIP PROCESSING MACHINERY</b>				<b>PAPER MILLS (cont)</b>			
Bridles	1.25	1.25	1.50	Presses – Felt & Suction	1.25	1.25	1.25
Coilers and uncoilers	1.00	1.00	1.25	Pulper	1.50	1.50	1.75
Edge Trimmers	1.00	1.25	1.50	Pumps – Vacuum	1.50	1.50	1.50
Flatteners	1.00	1.25	1.50	Reel (Surface Type)	1.25	1.25	1.50
Loopers (accumulators)	1.00	1.00	1.00	Screens			
Pinch rolls	1.00	1.25	1.50	Chip	1.50	1.50	1.50
Scrap choppers	1.00	1.25	1.50	Rotary	1.50	1.50	1.50
Shears	1.50	1.50	1.75	Vibrating	1.75	1.75	1.75
Slitters	1.00	1.25	1.50	Size Press	1.25	1.25	1.25
<b>MILLS, ROTARY TYPE</b>				Supercalendar <sup>3)</sup>	1.25	1.25	1.25
Ball & Rod				Thickener (AC Motor)	1.50	1.50	1.50
Spur Ring Gear	1.50	1.50	1.75	Thickener (DC Motor)	1.25	1.25	1.25
Helical Ring Gear	1.50	1.50	1.50	Washer (AC Motor)	1.50	1.50	1.50
Direct Connected	1.50	1.50	1.75	Washer (DC Motor)	1.25	1.25	1.25
Cement Kilns	1.50	1.50	1.50	Wind and Unwind Stand	1.00	1.00	1.00
Dryers & Coolers	1.50	1.50	1.50	Winders (Surface Type)	1.25	1.25	1.25
<b>MIXERS CONCRETE</b>				Yankee Dryers <sup>2)</sup>	1.25	1.25	1.25
<b>PAPER MILLS<sup>1)</sup></b>				<b>PLASTICS INDUSTRY – PRIMARY PROCESSING</b>			
Agitator (Mixer)	1.50	1.50	1.50	Intensive Internal Mixers			
Agitator for Pure liquors	1.25	1.25	1.25	Batch Mixers	1.75	1.75	1.75
Barking Drums	1.75	1.75	1.75	Continuous Mixers	1.50	1.50	1.50
Barkers – Mechanical	1.75	1.75	1.75	Batch Drop Mill – 2 smooth rolls			
Beater	1.50	1.50	1.50	Cont. Feed, Holding & Biend Mill	1.25	1.25	1.25
Breaker Stack	1.25	1.25	1.25	Calendars	1.50	1.50	1.50
Calender <sup>2)</sup>	1.25	1.25	1.25	<b>PLASTICS INDUSTRY – SECONDARY PROCESSING</b>			
Chipper	1.75	1.75	1.75	Blow Molders	1.50	1.50	1.50
Chip Feeder	1.50	1.50	1.50	Coating	1.25	1.25	1.25
Coating Rolls	1.25	1.25	1.25	Film	1.25	1.25	1.25
Conveyors				Pipe	1.25	1.25	1.25
Chip, Bark, Chemical log (including Slab)	1.25	1.25	1.25	Pre-Plasticizers	1.50	1.50	1.50
Couch Rolls	1.25	1.25	1.25	Rods	1.25	1.25	1.25
Cutter	1.75	1.75	1.75	Sheet	1.25	1.25	1.25
Cylinder Molds	1.25	1.25	1.25	Tubing	1.25	1.25	1.50
Dryers <sup>2)</sup>				<b>PULLERS – BARGE HAUL</b>			
Paper Machine	1.25	1.25	1.25		1.00	1.50	1.75
Conveyor Type	1.25	1.25	1.25	<b>PUMPS</b>			
Embosser	1.25	1.25	1.25	Centrifugal	1.00	1.00	1.25
Extruder	1.50	1.50	1.50	Proportioning	1.00	1.25	1.50
Fourdrinier Rolls (Includes Lump Breaker, Dandy Roll, Wire Turning, and Return Rolls)	1.25	1.25	1.25	Reciprocating			
Jordan	1.25	1.25	1.25	Single Acting, 3 or more cylinders	1.00	1.25	1.50
Kiln Drive	1.50	1.50	1.50	Double Acting, 2 or more cylinders	1.00	1.25	1.50
Mt. Hope Roll	1.25	1.25	1.25	Rotary			
Paper Rolls	1.25	1.25	1.25	Gear Type	1.00	1.00	1.50
				Lobe	1.00	1.00	1.25
				Vane	1.00	1.00	1.25



Application	Load Duration		
	Up to 3 hrs per day	3-10 hrs per day	Over 10 hrs per day
<b>RUBBER INDUSTRY</b>			
Intensive Internal Mixers			
Batch Mixers	1.50	1.75	1.75
Continuous Mixers	1.25	1.50	1.50
Mixing Mill			
2 smooth rolls	1.50	1.50	1.50
1 or 2 corrugated rolls	1.75	1.75	1.75
Batch Drop Mill – 2 smooth rolls	1.50	1.50	1.50
Cracker Warmer – 2 roll, 1 corrugated roll	1.75	1.75	1.75
Cracker – 2 corrugated rolls	1.75	1.75	1.75
Holding, Feed & Blend Mill – 2 rolls	1.25	1.25	1.25
Refiner – 2 rolls	1.50	1.50	1.50
Calendars	1.50	1.50	1.50
<b>SAND MILLER</b>	1.00	1.25	1.50
<b>SEWAGE DISPOSAL EQUIPMENT</b>			
Bar Screens	1.00	1.00	1.25
Chemical Feeders		1.00	1.25
Dewatering Screens	1.00	1.25	1.50
Scum Breakers	1.00	1.25	1.50
Slow or Rapid Mixers	1.00	1.25	1.50
Sludge Collectors	1.00	1.00	1.25
Thickener	1.00	1.25	1.50
Vacuum Filters	1.00	1.25	1.50
<b>SCREENS</b>			
Air Washing	1.00	1.00	1.25
Rotary – Stone or Gravel	1.00	1.25	1.50
Traveling Water Intake I	1.00	1.00	1.25
<b>SCREW CONVEYORS</b>			
Uniformly loaded or Fed			
Heavy Duty			
<b>SUGAR INDUSTRY</b>			
Beet Slicer	1.50	1.50	1.75
Cane Knives	1.50	1.50	1.50
Crushers	1.50	1.50	1.50
Mills (low speed end)	1.50	1.50	1.50

Application	Load Duration		
	Up to 3 hrs per day	3-10 hrs per day	Over 10 hrs per day
<b>TEXTILE INDUSTRY</b>			
Batchers	1.00	1.25	1.50
Calendars	1.00	1.25	1.50
Cards	1.00	1.25	1.50
Dry Cans	1.00	1.25	1.50
Dyeing Machinery	1.00	1.25	1.50
Looms	1.00	1.25	1.50
Mangles	1.00	1.25	1.50
Nappers	1.00	1.25	1.50
Pads	1.00	1.25	1.50
Siashers	1.00	1.25	1.50
Soapers	1.00	1.25	1.50
Spinners	1.00	1.25	1.50
Tenter Frames	1.00	1.25	1.50
Washers	1.00	1.25	1.50
Winders	1.00	1.25	1.50

**Notes to REDUCER SERVICE FACTOR table:**

- 1) Service factors for paper mill applications are applied to the nameplate rating of the electric motor at the motor rated based speed.
- 2) Anti-friction bearings only. Use 1.5 for sleeve bearings.
- 3) A service factor of 1.0 may be applied at base speed of a super calender operating over-speed range of part range constant horsepower, part range constant torque where the constant horsepower speed range is greater than 1.5 to 1. A service factor of 1.25 is applicable to super calenders operating over the entire speed range at constant torque or where the constant horsepower speed range is less than 1.5 to 1. Explanatory notes.





## 92.1 Series Approximate Gearmotor Weights [lb]

Type	63S	63L	71S	71L	80S	80L	90S	90L	100L	100LA	112M	132S	132M
SK 92072.1	21	23	25	33	33	36	47	-	-	-	-	-	-
SK 92172.1	26	27	29	37	37	40	51	54	-	-	-	-	-
SK 92372.1	36	37	40	48	48	50	61	65	84	106	120	-	-
SK 92672.1	45	46	64	72	72	75	85	89	108	130	144	179	189
SK 92772.1	52	53	89	97	97	100	110	114	133	155	169	198	214

Above weights are approximate. Depending upon ratio, oil quantity and optional equipment, reducer weights may be different than shown. Exact weights can be obtained after the unit is fully assembled.

## 92.1 Series Approximate Reducer Weights [lb]

Type	W	56C	140TC	180TC	210TC
SK 92072.1	15	14	14	-	-
SK 92172.1	19	18	18	-	-
SK 92372.1	31	29	29	31	-
SK 92672.1	55	53	53	55	59
SK 92772.1	80	78	78	80	84

Above weights are approximate. Depending upon ratio, oil quantity and optional equipment, reducer weights may be different than shown. Exact weights can be obtained after the unit is fully assembled.

## 93.1 Series Approximate Gearmotor Weights [lb]

Type	63S	63L	71S	71L	80S	80L	90S	90L	100L	100LA	112M	132S	132M
SK 93072.1	21	23	25	33	33	36	47	-	-	-	-	-	-
SK 93172.1	26	27	29	37	37	40	51	54	-	-	-	-	-
SK 93372.1	36	37	40	48	48	50	61	65	84	106	120	-	-
SK 93672.1	45	46	64	72	72	75	85	89	108	130	144	179	189
SK 93772.1	52	53	89	97	97	100	110	114	133	155	169	198	214

Above weights are approximate. Depending upon ratio, oil quantity and optional equipment, reducer weights may be different than shown. Exact weights can be obtained after the unit is fully assembled.

## 93.1 Series Approximate Reducer Weights [lb]

Type	W	56C	140TC	180TC	210TC
SK 93072.1	15	14	14	-	-
SK 93172.1	19	18	18	-	-
SK 93372.1	31	29	29	31	-
SK 93672.1	55	53	53	55	59
SK 93772.1	80	78	78	80	84

Above weights are approximate. Depending upon ratio, oil quantity and optional equipment, reducer weights may be different than shown. Exact weights can be obtained after the unit is fully assembled.

# 92.1 / 93.1 Series Gearmotors

## Gearmotor Selection

- 0.16 hp
- 0.25 hp
- 0.33 hp
- 0.5 hp
- 0.75 hp
- 1 hp
- 1.5 hp
- 2 hp
- 3 hp
- 5 hp
- 7.5 hp
- 10 hp

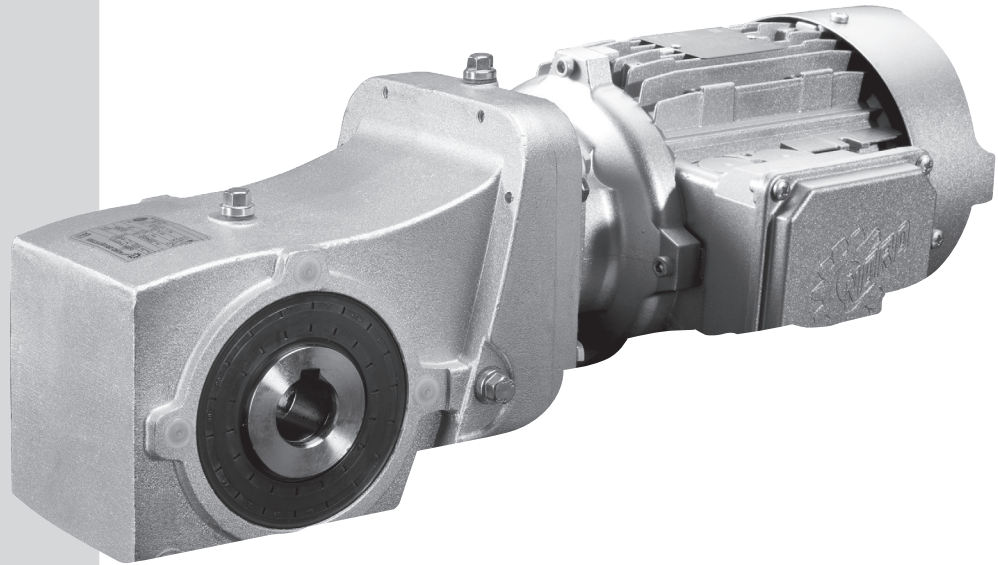

[www.nord.com](http://www.nord.com)

**82 Series Bevel Ordering Guide**

Order Code	Shaft/Mounting	Motor System	Mounting
SK	o	o	o
<p><b>82 Series Bevel</b></p> <p><b>SK 92372.1V - 71 5/4</b></p> <p><b>SK 93372.1L - 71 5/4</b></p> <p><b>SK 92372.1VF - 71 5/4</b></p>			

**SK 92372.1V - 71 5/4**  
92.1 Series Helical Bevel Unit  
Foot/B14 Mounted,  
Solid Shaft Side A

**SK 93372.1L - 71 5/4**  
93.1 Series Helical Bevel Unit  
B14 Mounted,  
Double Solid Shaft

**SK 92372.1VF - 71 5/4**  
92.1 Series Helical Bevel Unit  
Solid Shaft Side A  
B5 Flange Side A

Motor Power	Output Speed	Output Torque	Service Factor	AGMA Class	Gear Ratio
$P_n$	$n_2$	$T_o$	$f_s$		$i_{tot}$
[hp]	[rpm]	[lb-in]			
15	65	14614	2.8	III	27.35
	57	16714	2.5	III	31.28
	49	19348	2.2	III	36.21
	45	21223	2	III	39.72
	39	24023	1.8	II	44.96
	32	29153	1.5	II	54.56
	28	33352	1.3	I	62.42
	25	38599	1.1	I	72.24
	20	47111	0.9	*	88.17
	50	18803	3.3	III	35.19
43	21966	3.1	III	41.11	
35	26503	2.7	III	50.35	



# 2 Stage Bevel Ordering Guide



92.1 Bevel



93.1 Bevel



DRIVESYSTEMS

<b>SK</b>	①	②	③	④	-	⑤
	Gear Unit	Shaft/Mounting	Shaft/Mounting Options	Reducer Options		Motor/Input
						Motor Options
						see page 28
						see page 153

① Gear Unit	
92072.1	93072.1
92172.1	93172.1
92372.1	93372.1
92672.1	93672.1
92772.1	93772.1

② 92.1 Shaft/Mounting	
V - Universal Feet/B14 Face Flange/Solid Shaft	A - Universal Feet/B14 Face Flange/ Hollow Shaft
VF - Universal Feet/B5 Flange/Solid Shaft	AF - Universal Feet/B5 Flange/ Hollow Shaft
L - Universal Feet/B14 Face Flange/Double Solid Shaft	

② 93.1 Shaft/Mounting	
V - B14 Face Flange/Solid Shaft	A - B14 Face Flange/Hollow Shaft
VF - B5 Flange/ Solid Shaft	AF - B5 Flange/Hollow Shaft
L - B14 Face Flange/ Double Solid Shaft	AX - Tapped Feet/B14 Face Flange/Hollow Shaft
VX - Tapped Feet/B14 Face Flange/Solid Shaft	AXF - Tapped Feet/B5 Flange/Hollow Shaft
VXF - Tapped Feet/B5 Flange/Solid Shaft	
LX - Tapped Feet/B14 Face Flange/Double Solid Shaft	

③ Shaft/Mounting Options	
<input type="checkbox"/> Keyed Hollow Shaft  22	<input type="checkbox"/> D - Torque Arm  23
<input type="checkbox"/> SH - Shrink Disc & Cover  22	<input type="checkbox"/> SM - Stainless Steel Shaft  23
<input type="checkbox"/> MH - GRIPMAXX™  25	<input type="checkbox"/> SWV - Special Solid Shaft  23
<input type="checkbox"/> H - Hollow Shaft Cover  22	<input type="checkbox"/> SWA - Special Hollow Shaft  23
<input type="checkbox"/> B - Fixing Element Kit  23	<input type="checkbox"/> Worm Footplate Kit  21

④ Reducer Options	
<input type="checkbox"/> OSG - Oil Sight Glass  24	<input type="checkbox"/> LL - Long Term Storage  25
<input type="checkbox"/> MDP - Magnetic Drain Plug  25	<input type="checkbox"/> PR - Flange Pilot Removal  21
<input type="checkbox"/> ADP - Additional Drain Plug  25	<input type="checkbox"/> VI - Flouro-rubber Seals  24

⑤ Input Shaft	NEMA Adapter	IEC	Integral Motors	Integral Premium Efficient Motors	Integral Intermittent Duty (60 min) Motors
W	N56C N140TC N180TC N210TC N250TC	IEC 63 IEC 71 IEC 80 IEC 90 IEC 100 IEC 112 IEC 132 IEC 160	63S/4 - 0.16hp 63L/4 - 0.25hp 71S/4 - 0.33hp 71L/4 - 0.50hp 80S/4 - 0.75hp	80LP/4 - 1hp 90SP/4 - 1.5hp 90LP/4 - 2hp 100LP/4 - 3hp 112MP/4 - 5hp 132SP/4 - 7.5hp 132MP/4 - 10hp	80L/4 - 1hp 90S/4 - 1.5hp 90L/4 - 2hp 100L/4 - 3hp 100LA/4 - 5hp 112M/4 - 5.4hp 132S/4 - 7.5hp 132M/4 - 10hp
				Other Speeds Available	Other Speeds Available

## Product Specifications

**Ratio**  
 :1  
 see pages 65 - 82  
 —OR—  
**Output Speed**  
 rpm  
 see pages 65 - 82

**Mounting Position**

- M1
- M2
- M3
- M4
- M5
- M6
- Special \_\_\_\_\_

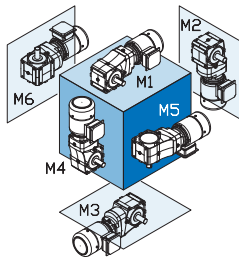

**Paint**

- Standard Stainless Steel Paint
- NSD+ (gray)
- NSD+W (white)
- NSD-X3 (gray)
- NSD-X3W (white)
- NSD-Tuph
- Special \_\_\_\_\_

**Lubricant**

- Standard
- Synthetic
- Food Grade
- Other \_\_\_\_\_

<p><b>Solid Shaft Side</b> (if required)</p> <ul style="list-style-type: none"> <li><input type="radio"/> Shaft Side A</li> <li><input type="radio"/> Shaft Side B</li> <li><input type="radio"/> Shaft Side A&amp;B see page 17</li> </ul>	<p><b>Hollow Shaft Diameter</b> (if required)</p> <input style="width: 60px; height: 20px;" type="text"/> see page 141	<p><b>B5 Flange Side</b> (if required)</p> <ul style="list-style-type: none"> <li><input type="radio"/> Flange Side A</li> <li><input type="radio"/> Flange Side B</li> <li><input type="radio"/> Flange Side A&amp;B see page 17</li> </ul>	<p><b>B5 Flange Diameter</b> (if required)</p> <input style="width: 60px; height: 20px;" type="text"/>	<p><b>Torque Arm Side &amp; Location</b> (if required)</p> <ul style="list-style-type: none"> <li><input type="radio"/> Side A</li> <li><input type="radio"/> Side B</li> </ul> <input style="width: 40px; height: 20px;" type="text"/> Location see page 17	<p><b>Shrink Disc /GRIPMAXX™ Side</b> (if required)</p> <ul style="list-style-type: none"> <li><input type="radio"/> Side A</li> <li><input type="radio"/> Side B</li> </ul> see page 17	<p><b>H66 Side</b> (if required)</p> <ul style="list-style-type: none"> <li><input type="radio"/> H66 Side A</li> <li><input type="radio"/> H66 Side B</li> </ul> see page 17
---	---	--	--	--	--	---

## Gearmotor Only Details

**Voltage & Frequency**

- 230/460V-60Hz (460V only ≥ 40 hp)
- 575V-60Hz
- 208V-60Hz
- 400V-50Hz
- 115/230V-60Hz, 1 ph.
- Other \_\_\_\_\_

### Terminal Box Pos.

- TB1
- TB2
- TB3
- TB4

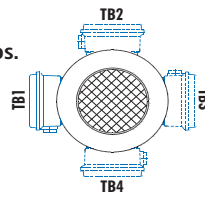

Mtg. Pos. M1 Shown

### Conduit Entry Loc.

- CE I \*
- CE II
- CE III \*
- CE IV

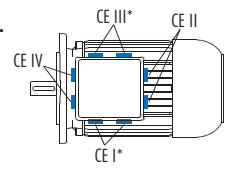

\* Brakemotor  
Mtg. Pos. M1 Shown

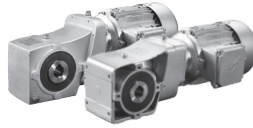

## Examples of Available Helical-bevel Units with Solid Shaft Design

**SK 92372.1V - 71 S/4**  
92.1 Series Helical Bevel Unit  
Foot/B14 Mounted,  
Solid Shaft Side A

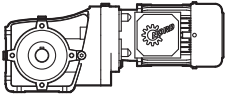

**SK 93372.1L - 71 S/4**  
93.1 Series Helical Bevel Unit  
B14 Mounted,  
Double Solid Shaft

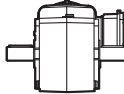
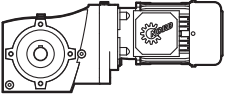

**SK 92372.1VF - 71 S/4**  
92.1 Series Helical Bevel Unit  
Solid Shaft Side A  
B5 Flange Side A

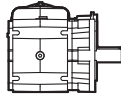
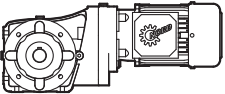

**SK 93372.1VD - 71 S/4**  
93.1 Series Helical Bevel Unit  
Solid Shaft Side B  
Torque Arm Side A @ 270°

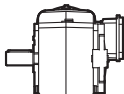
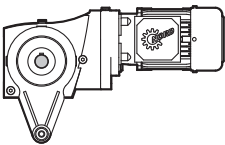

## Examples of Available Helical-bevel Units with Hollow Shaft Design

**SK 93372.1A - 71 S/4**  
93.1 Series Helical Bevel Unit  
Hollow Shaft,  
B14 Flange Side A & B  
Two Stage

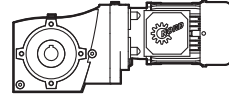

**SK 93372.1AF - 71 S/4**  
93.1 Series Helical Bevel Unit  
Hollow Shaft,  
B5 Flange Side A

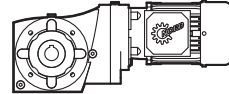

**SK 93372.1AD - 71 S/4**  
93.1 Series Helical Bevel Unit  
Hollow Shaft

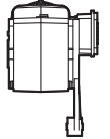
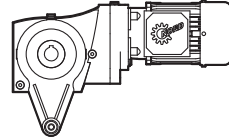

**SK 92372.1AZSH - 71 S/4**  
92.1 Series Helical Bevel Unit  
Hollow Shaft,  
B14 Flange Side A & B,  
Shrink Disc & Cover Side B

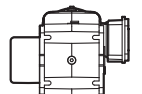
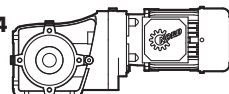

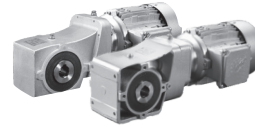

## Explanation of Selection Tables

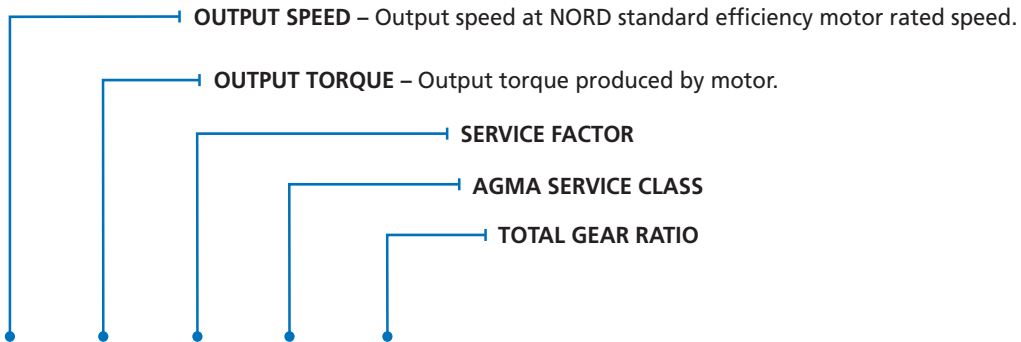

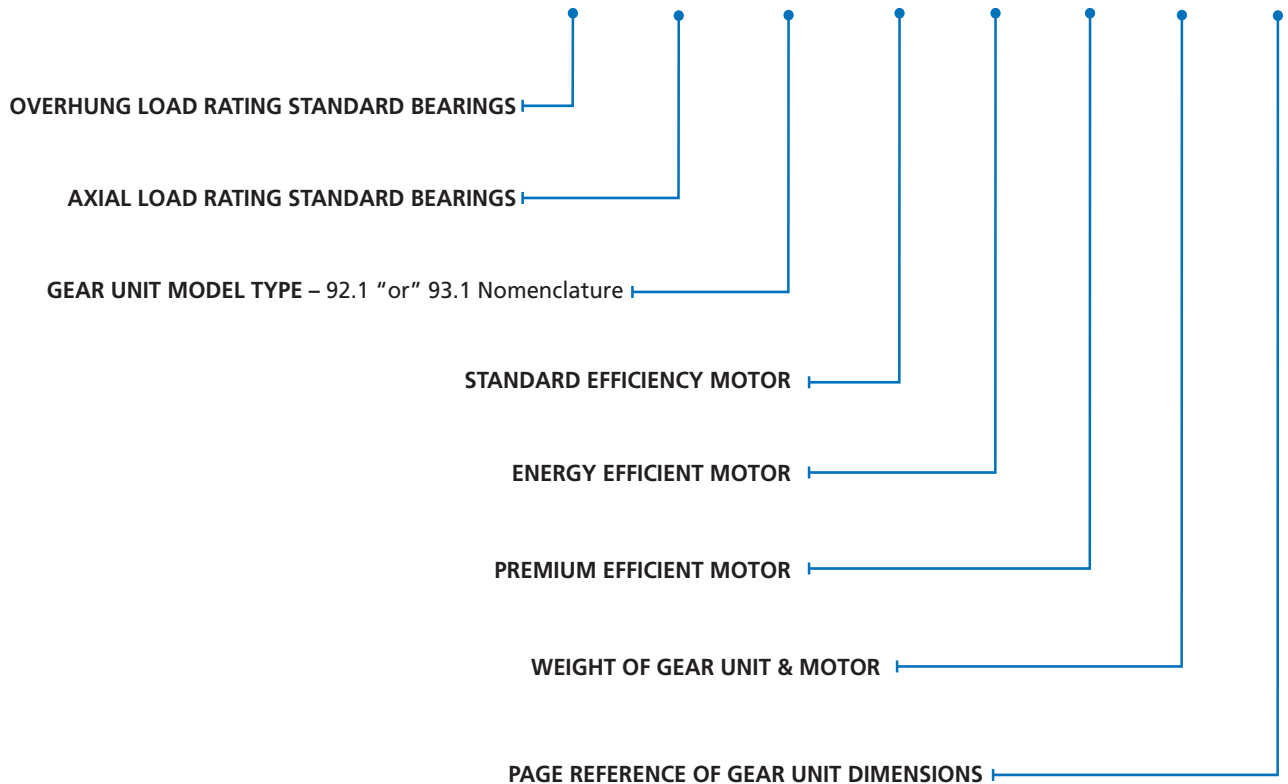

Motor Power $P_n$ [hp]	Output Speed $n_2$ [rpm]	Output Torque $T_2$ [lb-in]	Service Factor $f_B$	AGMA Class	Gear Ratio $i_{tot}$	Standard Bearings		Model Type	Gearmotor Type			Weight  [lb]	Dim. Page
						$F_R$ OHL [lb]	$F_A$ Thrust [lb]		Std. Eff. 	Energy Eff. 	Prem. Eff. 		
0.33	460	45	35.4	III	3.72	1488	2582	SK 92372.1 or SK 93372.1	90 S/4	90 SH/4	90 SP/4	40	98
	397	52	31.4	III	4.31	1488	2764						
	333	62	26.3	III	5.13	1488	3009						



GEARMOTORS



Motor Power $P_n$ [hp]	Output Speed $n_2$ [rpm]	Output Torque $T_2$ [lb-in]	Service Factor $f_B$	AGMA Class	Gear Ratio $i_{tot}$	Standard Bearings		Model Type	Gearmotor Type	Weight  [lb]	Dim. Page
						$F_R$ OHL [lb]	$F_A$ Thrust [lb]				
						Std. Eff. 					
0.16	475	21	27.5	III	3.58	884	1650	SK 92072.1 or SK 93072.1	63S/4	21	90
	428	24	25.5	III	3.97	914	1736				
	365	28	20.8	III	4.65	963	1829				
	329	31	19.3	III	5.17	996	1892				
	292	35	18.4	III	5.83	1036	1968				
	255	40	15.2	III	6.67	1083	2023				
	224	45	14.2	III	7.58	1124	2023				
	196	51	12.7	III	8.67	1124	2023				
	173	58	11.5	III	9.85	1124	2023				
	153	66	8.7	III	11.11	1124	2023				
	133	76	6.9	III	12.78	1124	2023				
	106	95	6.2	III	16.00	1124	2023				
	92	110	4.8	III	18.52	1124	2023				
	82	123	5.8	III	20.80	1124	2023				
	71	143	4.9	III	24.07	1124	2023				
	63	161	3.6	III	27.16	1124	2023				
	54	187	3.1	III	31.57	1124	2023				
	48	211	2.7	III	35.62	1124	2023				
	41	243	2.1	III	40.98	1124	2023				
	36	283	1.4	II	47.67	1124	2023				
32	319	1.4	II	53.78	1124	2023					
27	367	1.4	II	61.88	1124	2023					
	475	21	36.7	III	3.58	1078	1827	SK 92172.1 or SK 93172.1	63S/4	26	94
	442	23	34.5	III	3.85	1103	1890				
	396	25	36.8	III	4.30	1112	1996				
	347	29	32.6	III	4.89	1112	2134				
	323	31	30.4	III	5.26	1112	2217				
	295	34	23.8	III	5.77	1112	2300				
	260	39	21.3	III	6.53	1112	2393				
	245	41	23.6	III	6.94	1112	2442				
	217	46	21.1	III	7.83	1112	2540				
	204	49	20.6	III	8.33	1112	2592				
	188	54	15.5	III	9.03	1112	2659				
	179	56	16.8	III	9.49	1112	2698				
	167	60	14.0	III	10.15	1112	2698				
	157	64	15.6	III	10.83	1112	2698				
	140	72	14.0	III	12.18	1112	2698				
	138	73	13.1	III	12.34	1112	2698				
	123	82	11.6	III	13.87	1112	2698				
	112	90	9.1	III	15.23	1112	2698				
	82	123	7.5	III	20.67	1111	2698				
	69	147	7.2	III	24.80	1111	2698				
60	168	5.7	III	28.24	1110	2698					
55	184	5.2	III	31.00	1110	2698					
48	209	4.6	III	35.31	1109	2698					
46	220	3.6	III	37.14	1109	2698					
44	230	3.6	III	38.75	1108	2698					
40	251	3.6	III	42.30	1108	2698					
37	275	3.0	III	46.43	1107	2698					
30	332	1.6	II	56.00	1104	2698					
27	378	1.6	II	63.78	1102	2698					
24	415	1.6	II	70.00	1100	2698					

(AGMA Class I =  $f_B$  1.0 - 1.39 II =  $f_B$  1.4 - 1.99 III =  $f_B$   $\geq$  2.0 \* =  $f_B$   $<$  1.0)



# 0.16 hp Gearmotors

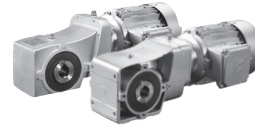





GEARMOTORS

Motor Power $P_n$ [hp]	Output Speed $n_2$ [rpm]	Output Torque $T_2$ [lb-in]	Service Factor $f_B$	AGMA Class	Gear Ratio $i_{tot}$	Standard Bearings		Model Type	Gearmotor Type	Weight  [lb]	Dim. Page					
						$F_R$ OHL [lb]	$F_A$ Thrust [lb]									
						Std. Eff. 										
0.16	457	22	72.6	III	3.72	1488	2602	SK 92372.1 or SK 93372.1	63S/4	36	98					
	395	26	64.5	III	4.31	1488	2788									
	332	30	53.8	III	5.13	1488	3038					36	118			
	291	35	48.3	III	5.83	1488	3248									
	255	40	45.9	III	6.67	1488	3372									
	243	42	42.8	III	7.01	1488	3372									
	207	49	37.9	III	8.19	1488	3372									
	187	54	35.7	III	9.11	1488	3372									
	166	61	26.9	III	10.22	1488	3372									
	165	61	31.8	III	10.33	1488	3372									
	152	66	29.0	III	11.20	1488	3372									
	135	75	21.9	III	12.56	1488	3372									
	120	84	23.0	III	14.12	1488	3372									
	107	94	17.3	III	15.84	1488	3372									
	41	246	6.6	III	41.46	1486	3372									
	36	277	5.9	III	46.64	1485	3372									
	34	293	4.3	III	49.46	1485	3372									
	31	329	4.2	III	55.49	1484	3372									
		301	33	82.0	III	5.64	1905					3923	SK 92672.1 or SK 93672.1	63S/4	45	102
		229	44	70.0	III	7.44	1905					4496				
204		49	62.7	III	8.33	1905	4496	45	122							
181		56	56.4	III	9.39	1905	4496									
167		60	53.3	III	10.16	1905	4496									
149		68	47.3	III	11.39	1905	4496									
132		76	42.2	III	12.84	1904	4496									
118		85	32.8	III	14.40	1904	4496									
109		92	34.8	III	15.56	1904	4496									
97		104	27.1	III	17.46	1904	4496									
	192	52	93.6	III	8.85	2352	5620	SK 92772.1 or SK 93772.1	63S/4	52	106					
	151	67	76.0	III	11.28	2352	5620									
	136	74	71.1	III	12.50	2352	5620					52	126			
	123	82	65.5	III	13.79	2352	5620									
	110	91	61.1	III	15.42	2352	5620									
	100	101	56.3	III	17.08	2352	5620									
	90	112	50.7	III	18.84	2352	5620									
	89	114	49.0	III	19.17	2352	5620									
	80	125	44.5	III	21.14	2352	5620									
	75	134	42.9	III	22.59	2352	5620									
	69	146	39.7	III	24.64	2352	5620									
	67	150	37.1	III	25.34	2352	5620									
61	164	34.0	III	27.65	2351	5620										

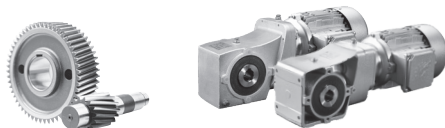
(AGMA Class I =  $f_B$  1.0 - 1.39 II =  $f_B$  1.4 - 1.99 III =  $f_B$   $\geq$  2.0 \* =  $f_B$  < 1.0)





Motor Power $P_n$ [hp]	Output Speed $n_2$ [rpm]	Output Torque $T_2$ [lb-in]	Service Factor $f_B$	AGMA Class	Gear Ratio $i_{tot}$	Standard Bearings		Model Type	Gearmotor Type	Weight  [lb]	Dim. Page		
						$F_R$ OHL [lb]	$F_A$ Thrust [lb]						
0.25	469	34	17.4	III	3.58	883	1649	SK 92072.1 or SK 93072.1	63 L/4	 [lb]	90		
	423	37	16.1	III	3.97	913	1733						
	361	44	13.2	III	4.65	961	1824					23	110
	325	48	12.2	III	5.17	994	1887						
	288	55	11.7	III	5.83	1033	1961						
	252	63	9.6	III	6.67	1079	2023						
	222	71	9.0	III	7.58	1124	2023						
	194	81	8.1	III	8.67	1124	2023						
	171	92	7.3	III	9.85	1124	2023						
	151	104	5.5	III	11.11	1124	2023						
	131	120	4.4	III	12.78	1124	2023						
	105	150	3.9	III	16.00	1124	2023						
	91	174	3.1	III	18.52	1124	2023						
	81	195	3.7	III	20.80	1124	2023						
	70	226	3.1	III	24.07	1124	2023						
	62	255	2.3	III	27.16	1124	2023						
	53	296	1.9	II	31.57	1124	2023						
	47	334	1.7	II	35.62	1124	2023						
	41	384	1.4	I	40.98	1124	2023						
	35	447	0.9	*	47.67	1124	2023						
31	504	0.9	*	53.78	1124	2023							
27	580	0.9	*	61.88	1124	2023							
0.25	469	34	23.2	III	3.58	1078	1828	SK 92172.1 or SK 93172.1	63 L/4	 [lb]	94		
	437	36	21.8	III	3.85	1104	1892						
	391	40	23.3	III	4.30	1112	1997					27	114
	343	46	20.6	III	4.89	1112	2135						
	320	49	19.2	III	5.26	1112	2217						
	291	54	15.0	III	5.77	1112	2296						
	257	61	13.4	III	6.53	1112	2388						
	242	65	14.9	III	6.94	1112	2436						
	214	73	13.4	III	7.83	1112	2533						
	202	78	13.0	III	8.33	1112	2584						
	186	85	9.8	III	9.03	1112	2650						
	177	89	10.6	III	9.49	1112	2695						
	165	95	8.8	III	10.15	1111	2698						
	155	102	9.8	III	10.83	1111	2698						
	138	114	8.8	III	12.18	1111	2698						
	136	116	8.3	III	12.34	1111	2698						
	121	130	7.3	III	13.87	1111	2698						
	110	143	5.8	III	15.23	1111	2698						
	81	194	4.7	III	20.67	1109	2698						
	68	233	4.6	III	24.80	1108	2698						
59	265	3.6	III	28.24	1107	2698							
54	291	3.3	III	31.00	1106	2698							
48	331	2.9	III	35.31	1104	2698							
45	348	2.3	III	37.14	1104	2698							
43	363	2.3	III	38.75	1103	2698							
40	397	2.3	III	42.30	1101	2698							
36	435	1.9	II	46.43	1099	2698							
30	525	1.0	I	56.00	1092	2698							
26	598	1.0	I	63.78	1087	2698							
24	657	1.0	I	70.00	1081	2698							

(AGMA Class I =  $f_B$  1.0 - 1.39 II =  $f_B$  1.4 - 1.99 III =  $f_B$   $\geq$  2.0 \* =  $f_B$  < 1.0)



# 0.25 hp Gearmotors

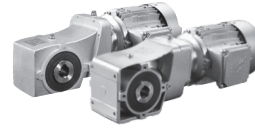

GEARMOTORS

Motor Power $P_n$ [hp]	Output Speed $n_2$ [rpm]	Output Torque $T_2$ [lb-in]	Service Factor $f_B$	AGMA Class	Gear Ratio $i_{tot}$	Standard Bearings		Model Type	Gearmotor Type	Weight  [lb]	Dim. Page					
						$F_R$ OHL [lb]	$F_A$ Thrust [lb]									
						Std. Eff. 										
0.25	452	35	45.9	III	3.72	1488	2609	SK 92372.1 or SK 93372.1	63 L/4	37	98					
	390	40	40.8	III	4.31	1488	2795									
	328	48	34.0	III	5.13	1488	3045					37	118			
	288	55	30.6	III	5.83	1488	3255									
	252	63	29.0	III	6.67	1488	3372									
	240	66	27.1	III	7.01	1488	3372									
	205	77	24.0	III	8.19	1488	3372									
	184	85	22.6	III	9.11	1488	3372									
	164	96	17.0	III	10.22	1488	3372									
	163	97	20.1	III	10.33	1488	3372									
	150	105	18.4	III	11.20	1488	3372									
	134	118	13.8	III	12.56	1488	3372									
	119	132	14.6	III	14.12	1488	3372									
	106	149	11.0	III	15.84	1487	3372									
	41	389	4.2	III	41.46	1483	3372									
	36	437	3.7	III	46.64	1481	3372									
	34	464	2.7	III	49.46	1480	3372									
	30	520	2.7	III	55.49	1478	3372									
		298	53	51.9	III	5.64	1905					3937	SK 92672.1 or SK 93672.1	63 L/4	46	102
		226	70	44.3	III	7.44	1905					4496				
202		78	39.6	III	8.33	1904	4496	46	122							
179		88	35.7	III	9.39	1904	4496									
165		95	33.7	III	10.16	1904	4496									
148		107	29.9	III	11.39	1904	4496									
131		120	26.7	III	12.84	1904	4496									
117		135	20.8	III	14.40	1904	4496									
108		146	22.0	III	15.56	1904	4496									
96		164	17.1	III	17.46	1904	4496									
		190	83	59.2	III	8.85	2352	5620	SK 92772.1 or SK 93772.1	63 L/4	53	106				
		149	106	48.1	III	11.28	2352	5620								
	134	117	45.0	III	12.50	2352	5620	53					126			
	122	129	41.4	III	13.79	2352	5620									
	109	145	38.6	III	15.42	2352	5620									
	98	160	35.6	III	17.08	2351	5620									
	89	177	32.1	III	18.84	2351	5620									
	88	180	31.0	III	19.17	2351	5620									
	79	198	28.1	III	21.14	2351	5620									
	74	212	27.2	III	22.59	2351	5620									
	68	231	25.1	III	24.64	2351	5620									
	66	238	23.5	III	25.34	2351	5620									
61	259	21.5	III	27.65	2351	5620										

(AGMA Class I =  $f_B$  1.0 - 1.39 II =  $f_B$  1.4 - 1.99 III =  $f_B$   $\geq$  2.0 \* =  $f_B$  < 1.0)



Motor Power $P_n$ [hp]	Output Speed $n_2$ [rpm]	Output Torque $T_2$ [lb-in]	Service Factor $f_B$	AGMA Class	Gear Ratio $i_{tot}$	Standard Bearings		Model Type	Gearmotor Type	Weight  [lb]	Dim. Page
						$F_R$ OHL [lb]	$F_A$ Thrust [lb]				
0.33	478	44	13.4	III	3.58	874	1625	SK 92072.1 or SK 93072.1	71 S/4	25	90
	430	48	12.5	III	3.97	904	1714				
	367	57	10.2	III	4.65	951	1804	SK 92172.1 or SK 93172.1	71 S/4	29	114
	331	63	9.4	III	5.17	983	1865				
	293	71	9.0	III	5.83	1021	1938				
	257	81	7.4	III	6.67	1066	2019				
	226	92	6.9	III	7.58	1110	2023				
	197	105	6.2	III	8.67	1124	2023				
	174	120	5.6	III	9.85	1124	2023				
	154	135	4.3	III	11.11	1124	2023				
	134	155	3.4	III	12.78	1124	2023				
	107	195	3.0	III	16.00	1124	2023				
	92	225	2.4	III	18.52	1124	2023				
	82	253	2.8	III	20.80	1124	2023				
	71	293	2.4	III	24.07	1124	2023				
	63	330	1.7	II	27.16	1124	2023				
	54	384	1.5	II	31.57	1124	2023				
	48	433	1.3	I	35.62	1124	2023				
	42	498	1.0	I	40.98	1124	2023				
	478	44	17.9	III	3.58	1069	1806				
445	47	16.8	III	3.85	1094	1867					
398	52	18.0	III	4.30	1112	1971	SK 92172.1 or SK 93172.1	71 S/4	29	114	
349	60	15.9	III	4.89	1112	2104					
325	64	14.8	III	5.26	1112	2184					
296	70	11.6	III	5.77	1112	2273					
262	79	10.4	III	6.53	1112	2362					
246	84	11.5	III	6.94	1112	2409					
218	95	10.3	III	7.83	1111	2504					
205	101	10.0	III	8.33	1111	2554					
189	110	7.6	III	9.03	1111	2617					
180	115	8.2	III	9.49	1111	2662					
168	123	6.8	III	10.15	1111	2698					
158	132	7.6	III	10.83	1111	2698					
140	148	6.8	III	12.18	1111	2698					
139	150	6.4	III	12.34	1111	2698					
123	169	5.7	III	13.87	1110	2698					
112	185	4.4	III	15.23	1110	2698					
83	251	3.7	III	20.67	1108	2698					
69	302	3.5	III	24.80	1106	2698					
61	344	2.8	III	28.24	1104	2698					
55	377	2.5	III	31.00	1102	2698					
48	429	2.2	III	35.31	1099	2698					
46	452	1.8	II	37.14	1098	2698					
44	471	1.7	II	38.75	1096	2698					
40	515	1.8	II	42.30	1093	2698					
37	565	1.5	II	46.43	1089	2698					



(AGMA Class I =  $f_B$  1.0 - 1.39 II =  $f_B$  1.4 - 1.99 III =  $f_B$   $\geq$  2.0 \* =  $f_B$  < 1.0)

# 0.33 hp Gearmotors

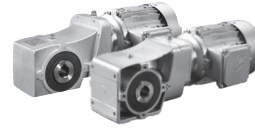



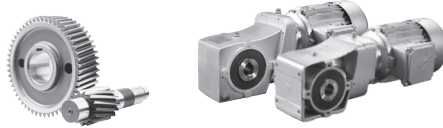

GEARMOTORS

Motor Power $P_n$ [hp]	Output Speed $n_2$ [rpm]	Output Torque $T_2$ [lb-in]	Service Factor $f_B$	AGMA Class	Gear Ratio $i_{tot}$	Standard Bearings		Model Type	Gearmotor Type	Weight  [lb]	Dim. Page			
						$F_R$ OHL [lb]	$F_A$ Thrust [lb]							
						Std. Eff. 								
0.33	460	45	35.4	III	3.72	1488	2582	SK 92372.1 or SK 93372.1	71 S/4	40	98			
	397	52	31.4	III	4.31	1488	2764							
	333	62	26.3	III	5.13	1488	3009					40	118	
	293	71	23.6	III	5.83	1488	3214							
	257	81	22.4	III	6.67	1488	3372							
	244	85	20.9	III	7.01	1488	3372							
	209	100	18.5	III	8.19	1488	3372							
	188	111	17.4	III	9.11	1488	3372							
	167	124	13.1	III	10.22	1488	3372							
	165	126	15.5	III	10.33	1488	3372							
	153	136	14.2	III	11.20	1487	3372							
	136	153	10.7	III	12.56	1487	3372							
	121	172	11.2	III	14.12	1487	3372							
	108	193	8.5	III	15.84	1487	3372							
	52	399	4.4	III	32.80	1482	3372							
	46	448	3.6	III	36.80	1481	3372							
	41	504	3.2	III	41.46	1479	3372							
	37	567	2.9	III	46.64	1476	3372							
	35	602	2.1	III	49.46	1475	3372							
	31	675	2.1	III	55.49	1471	3372							
303	69	40.0	III	5.64	1905	3895	SK 92672.1 or SK 93672.1	71 S/4	64	102				
230	90	34.2	III	7.44	1904	4486								
205	101	30.6	III	8.33	1904	4496					64	122		
182	114	27.5	III	9.39	1904	4496								
168	124	26.0	III	10.16	1904	4496								
150	139	23.1	III	11.39	1904	4496								
133	156	20.6	III	12.84	1904	4496								
119	175	16.0	III	14.40	1904	4496								
110	189	17.0	III	15.56	1904	4496								
98	212	13.2	III	17.46	1904	4496								
40	526	5.1	III	43.28	1899	4496								
35	591	4.8	III	48.56	1898	4496								
193	108	45.7	III	8.85	2352	5620					SK 92772.1 or SK 93772.1	71 S/4	89	106
152	137	37.1	III	11.28	2352	5620								
137	152	34.7	III	12.50	2352	5620								
124	168	31.9	III	13.79	2351	5620								
111	188	29.8	III	15.42	2351	5620								
100	208	27.5	III	17.08	2351	5620								
91	229	24.7	III	18.84	2351	5620								
89	233	23.9	III	19.17	2351	5620								
81	257	21.7	III	21.14	2351	5620								
76	275	20.9	III	22.59	2351	5620								
69	300	19.3	III	24.64	2351	5620								
67	308	18.1	III	25.34	2351	5620								
62	336	16.6	III	27.65	2350	5620								
29	726	5.3	III	59.68	2345	5620								
26	814	5.3	III	66.96	2344	5620								

(AGMA Class I =  $f_B$  1.0 - 1.39 II =  $f_B$  1.4 - 1.99 III =  $f_B$   $\geq$  2.0 \* =  $f_B$  < 1.0)



Motor Power $P_n$ [hp]	Output Speed $n_2$ [rpm]	Output Torque $T_2$ [lb-in]	Service Factor $f_B$	AGMA Class	Gear Ratio $i_{tot}$	Standard Bearings		Model Type	Gearmotor Type	Weight  [lb]	Dim. Page				
						$F_R$ OHL [lb]	$F_A$ Thrust [lb]								
						Std. Eff. 									
0.5	480	66	8.9	III	3.58	865	1600	SK 92072.1 or SK 93072.1	71 L/4	 33	90				
	433	73	8.3	III	3.97	894	1688								
	370	85	6.7	III	4.65	939	1779								
	333	95	6.3	III	5.17	970	1838								
	295	107	6.0	III	5.83	1007	1908								
	258	122	4.9	III	6.67	1050	1983								
	227	139	4.6	III	7.58	1092	2023								
	198	159	4.1	III	8.67	1124	2023								
	175	180	3.7	III	9.85	1124	2023								
	155	204	2.8	III	11.11	1124	2023								
	135	234	2.2	III	12.78	1124	2023								
	108	293	2.0	II	16.00	1124	2023								
	93	339	1.6	II	18.52	1124	2023								
	83	381	1.9	II	20.80	1124	2023								
	71	441	1.6	II	24.07	1124	2023								
	63	498	1.2	I	27.16	1124	2023								
	480	66	11.9	III	3.58	1060	1785					SK 92172.1 or SK 93172.1	71 L/4	 37	94
	447	70	11.2	III	3.85	1084	1845								
	400	79	11.9	III	4.30	1112	1945								
	352	90	10.6	III	4.89	1112	2075								
327	96	9.8	III	5.26	1111	2153									
298	106	7.7	III	5.77	1111	2246									
263	120	6.9	III	6.53	1111	2331									
248	127	7.7	III	6.94	1111	2376									
220	144	6.8	III	7.83	1111	2468									
206	153	6.7	III	8.33	1110	2516									
191	165	5.0	III	9.03	1110	2576									
181	174	5.4	III	9.49	1110	2620									
169	186	4.5	III	10.15	1110	2669									
159	198	5.0	III	10.83	1109	2698									
141	223	4.5	III	12.18	1109	2698									
139	226	4.2	III	12.34	1109	2698									
124	254	3.8	III	13.87	1108	2698									
113	279	3.0	III	15.23	1107	2698									
83	379	2.4	III	20.67	1102	2698									
69	454	2.3	III	24.80	1097	2698									
61	517	1.8	II	28.24	1093	2698									
55	568	1.7	II	31.00	1089	2698									
49	647	1.5	II	35.31	1082	2698									
44	710	1.2	I	38.75	1076	2698									





(AGMA Class I =  $f_B$  1.0 - 1.39 II =  $f_B$  1.4 - 1.99 III =  $f_B$   $\geq$  2.0 \* =  $f_B$  < 1.0)

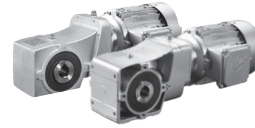

# 0.5 hp Gearmotors





GEARMOTORS

Motor Power $P_n$ [hp]	Output Speed $n_2$ [rpm]	Output Torque $T_2$ [lb-in]	Service Factor $f_B$	AGMA Class	Gear Ratio $i_{tot}$	Standard Bearings		Model Type	Gearmotor Type	Weight  [lb]	Dim. Page			
						$F_R$ OHL [lb]	$F_A$ Thrust [lb]							
						Std. Eff. 								
0.5	463	68	23.5	III	3.72	1488	2561	SK 92372.1 or SK 93372.1	71 L/4	48	98			
	399	79	20.9	III	4.31	1488	2740							
	335	94	17.4	III	5.13	1488	2980					48	118	
	295	107	15.7	III	5.83	1488	3181							
	258	122	14.9	III	6.67	1488	3372							
	245	128	13.9	III	7.01	1488	3372							
	210	150	12.3	III	8.19	1487	3372							
	189	167	11.6	III	9.11	1487	3372							
	168	187	8.7	III	10.22	1487	3372							
	166	189	10.3	III	10.33	1487	3372							
	154	205	9.4	III	11.20	1487	3372							
	137	230	7.1	III	12.56	1486	3372							
	122	259	7.5	III	14.12	1486	3372							
	109	290	5.6	III	15.84	1485	3372							
	52	601	2.9	III	32.80	1475	3372							
	47	674	2.4	III	36.80	1471	3372							
	41	760	2.1	III	41.46	1467	3372							
	37	854	1.9	II	46.64	1461	3372							
	35	906	1.4	I	49.46	1458	3372							
	31	1017	1.4	I	55.49	1450	3372							
	305	103	26.5	III	5.64	1904	3868	SK 92672.1 or SK 93672.1	71 L/4	72	102			
	231	136	22.7	III	7.44	1904	4458							
	206	153	20.3	III	8.33	1904	4496			72	122			
	183	172	18.3	III	9.39	1904	4496							
	169	186	17.3	III	10.16	1904	4496							
	151	209	15.3	III	11.39	1904	4496							
	134	235	13.7	III	12.84	1903	4496							
	119	264	10.6	III	14.40	1903	4496							
	111	285	11.3	III	15.56	1903	4496							
	98	320	8.8	III	17.46	1903	4496							
	40	793	3.4	III	43.28	1892	4496							
	35	890	3.2	III	48.56	1889	4496							
		194	162	30.3	III	8.85	2351			5620	SK 92772.1 or SK 93772.1	71 L/4	97	106
		152	207	24.6	III	11.28	2351			5620				
138		229	23.0	III	12.50	2351	5620	97	126					
125		253	21.2	III	13.79	2351	5620							
112		282	19.8	III	15.42	2351	5620							
101		313	18.2	III	17.08	2351	5620							
91		345	16.4	III	18.84	2350	5620							
90		351	15.9	III	19.17	2350	5620							
81		387	14.4	III	21.14	2350	5620							
76		414	13.9	III	22.59	2350	5620							
70		451	12.8	III	24.64	2349	5620							
68		464	12.0	III	25.34	2349	5620							
62		507	11.0	III	27.65	2349	5620							
29		1093	3.5	III	59.68	2337	5620							
26		1227	3.5	III	66.96	2333	5620							

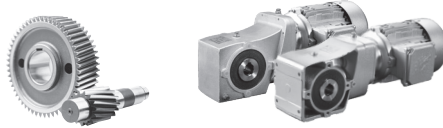
(AGMA Class I =  $f_B$  1.0 - 1.39 II =  $f_B$  1.4 - 1.99 III =  $f_B$   $\geq$  2.0 \* =  $f_B$  < 1.0)



Motor Power $P_n$ [hp]	Output Speed $n_2$ [rpm]	Output Torque $T_2$ [lb-in]	Service Factor $f_B$	AGMA Class	Gear Ratio $i_{tot}$	Standard Bearings		Model Type	Gearmotor Type	Weight  [lb]	Dim. Page				
						$F_R$ OHL [lb]	$F_A$ Thrust [lb]								
						Std. Eff. 									
0.75	478	99	5.9	III	3.58	855	1574	SK 92072.1 or SK 93072.1	80 S/4	33	90				
	430	110	5.5	III	3.97	883	1660								
	367	129	4.5	III	4.65	926	1751								
	331	143	4.2	III	5.17	955	1806								
	293	161	4.0	III	5.83	990	1873								
	257	184	3.3	III	6.67	1031	1940								
	226	209	3.0	III	7.58	1070	2012								
	197	240	2.7	III	8.67	1110	2023								
	174	272	2.5	III	9.85	1124	2023								
	154	307	1.9	II	11.11	1124	2023								
	134	353	1.5	II	12.78	1124	2023								
	107	442	1.3	I	16.00	1124	2023								
	82	575	1.2	I	20.80	1124	2023								
	478	99	7.9	III	3.58	1052	1766					SK 92172.1 or SK 93172.1	80 S/4	37	94
	445	106	7.4	III	3.85	1075	1824								
	398	119	7.9	III	4.30	1111	1922								
349	135	7.0	III	4.89	1111	2048									
325	145	6.5	III	5.26	1111	2123									
296	159	5.1	III	5.77	1110	2218									
262	180	4.6	III	6.53	1110	2296									
246	192	5.1	III	6.94	1110	2338									
218	217	4.5	III	7.83	1109	2427									
205	230	4.4	III	8.33	1108	2472									
189	250	3.3	III	9.03	1108	2526									
180	262	3.6	III	9.49	1107	2570									
168	281	3.0	III	10.15	1107	2613									
158	299	3.3	III	10.83	1106	2667									
140	337	3.0	III	12.18	1104	2698									
139	341	2.8	III	12.34	1104	2698									
123	384	2.5	III	13.87	1102	2698									
112	421	2.0	II	15.23	1100	2698									
83	571	1.6	II	20.67	1089	2698									
69	686	1.5	II	24.80	1078	2698									
61	781	1.2	I	28.24	1068	2698									
460	103	15.6	III	3.72	1488	2548	SK 92372.1 or SK 93372.1	80 S/4	48	98					
397	119	13.8	III	4.31	1488	2723									
333	142	11.6	III	5.13	1487	2959									
293	161	10.4	III	5.83	1487	3156									
257	184	9.8	III	6.67	1487	3363									
244	194	9.2	III	7.01	1487	3372									
209	227	8.1	III	8.19	1486	3372									
188	252	7.7	III	9.11	1486	3372									
167	283	5.8	III	10.22	1485	3372									
165	286	6.8	III	10.33	1485	3372									
153	310	6.2	III	11.20	1485	3372									



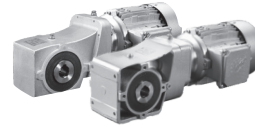

(AGMA Class I =  $f_B$  1.0 - 1.39 II =  $f_B$  1.4 - 1.99 III =  $f_B$   $\geq$  2.0 \* =  $f_B$  < 1.0)

# 0.75 hp Gearmotors



GEARMOTORS

Motor Power $P_n$ [hp]	Output Speed $n_2$ [rpm]	Output Torque $T_2$ [lb-in]	Service Factor $f_B$	AGMA Class	Gear Ratio $i_{tot}$	Standard Bearings		Model Type	Gearmotor Type	Weight  [lb]	Dim. Page				
						$F_R$ OHL [lb]	$F_A$ Thrust [lb]								
						Std. Eff. 									
0.75	136	347	4.7	III	12.56	1484	3372	SK 92372.1 or SK 93372.1	80 S/4	48	98				
	121	390	4.9	III	14.12	1483	3372								
	108	438	3.7	III	15.84	1481	3372								
	93	507	3.2	III	18.33	1479	3372								
	85	554	3.5	III	20.04	1477	3372								
	76	622	2.6	III	22.49	1474	3372								
	68	693	2.8	III	25.06	1470	3372								
	61	777	2.1	III	28.11	1466	3372								
	52	907	1.9	II	32.80	1458	3372								
	46	1017	1.6	II	36.80	1450	3372								
	41	1146	1.4	II	41.46	1439	3372								
	37	1289	1.3	I	46.64	1426	3372								
	303	156	17.6	III	5.64	1904	3855					SK 92672.1 or SK 93672.1	80 S/4	72	102
	230	206	15.0	III	7.44	1904	4439								
	205	230	13.4	III	8.33	1904	4496								
	182	260	12.1	III	9.39	1903	4496								
	168	281	11.4	III	10.16	1903	4496								
	150	315	10.1	III	11.39	1903	4496								
	133	355	9.1	III	12.84	1902	4496								
119	398	7.0	III	14.40	1901	4496									
110	430	7.5	III	15.56	1901	4496									
98	483	5.8	III	17.46	1900	4496									
86	553	5.0	III	20.00	1898	4496									
63	756	4.3	III	27.33	1893	4496									
56	848	3.3	III	30.67	1890	4496									
51	932	3.4	III	33.71	1887	4496									
45	1046	2.7	III	37.82	1883	4496									
40	1196	2.3	III	43.28	1876	4496									
35	1342	2.1	III	48.56	1868	4496									
193	245	20.1	III	8.85	2351	5620	SK 92772.1 or SK 93772.1	80 S/4	97	106					
152	312	16.3	III	11.28	2351	5620									
137	346	15.3	III	12.50	2350	5620									
124	381	14.0	III	13.79	2350	5620									
111	426	13.1	III	15.42	2350	5620									
100	472	12.1	III	17.08	2349	5620									
91	521	10.9	III	18.84	2348	5620									
89	530	10.5	III	19.17	2348	5620									
81	584	9.5	III	21.14	2348	5620									
76	624	9.2	III	22.59	2347	5620									
69	681	8.5	III	24.64	2346	5620									
67	701	8.0	III	25.34	2346	5620									
62	764	7.3	III	27.65	2345	5620									
39	1201	4.6	III	43.44	2334	5620									
36	1297	3.5	III	46.92	2331	5620									
32	1455	3.5	III	52.64	2325	5620									
29	1650	2.3	III	59.68	2318	5620									
26	1851	2.3	III	66.96	2309	5620									

(AGMA Class I =  $f_B$  1.0 - 1.39 II =  $f_B$  1.4 - 1.99 III =  $f_B$   $\geq$  2.0 \* =  $f_B$  < 1.0)



# 1.0 hp Gearmotors

Motor Power $P_n$ [hp]	Output Speed $n_2$ [rpm]	Output Torque $T_2$ [lb-in]	Service Factor $f_B$	AGMA Class	Gear Ratio $i_{tot}$	Standard Bearings		Model Type	Gearmotor Type			Weight  [lb]	Dim. Page							
						$F_R$ OHL [lb]	$F_A$ Thrust [lb]		Std. Eff. 	Energy Eff. 	Prem. Eff. 									
1.0	489	129	4.5	III	3.58	838	1528	SK 92072.1 or SK 93072.1	80 L/4	80 LH/4	80LP/4	36	90							
	440	143	4.2	III	3.97	865	1607						36	110						
	376	168	3.4	III	4.65	905	1708													
	339	186	3.2	III	5.17	932	1760													
	300	210	3.0	III	5.83	964	1822													
	263	240	2.5	III	6.67	1003	1882													
	231	273	2.3	III	7.58	1040	1947													
	202	312	2.1	III	8.67	1076	2023													
	178	355	1.9	II	9.85	1113	2023													
	158	400	1.4	II	11.11	1124	2023													
	137	460	1.1	I	12.78	1124	2023													
	109	576	1.0	I	16.00	1124	2023													
	84	749	1.0	I	20.80	1115	2023													
	489	129	6.0	III	3.58	1034	1724								SK 92172.1 or SK 93172.1	80 L/4	80 LH/4	80LP/4	40	94
	455	139	5.7	III	3.85	1057	1780													40
407	155	6.1	III	4.30	1093	1873														
358	176	5.4	III	4.89	1110	1992														
333	189	5.0	III	5.26	1110	2062														
303	208	3.9	III	5.77	1109	2162														
268	235	3.5	III	6.53	1108	2242														
252	250	3.9	III	6.94	1108	2282														
223	282	3.5	III	7.83	1106	2366														
210	300	3.4	III	8.33	1106	2407														
194	325	2.6	III	9.03	1105	2456														
184	342	2.8	III	9.49	1104	2500														
172	366	2.3	III	10.15	1103	2536														
162	390	2.6	III	10.83	1101	2588														
144	439	2.3	III	12.18	1098	2670														
142	444	2.2	III	12.34	1098	2683														
126	500	1.9	II	13.87	1094	2698														
115	548	1.5	II	15.23	1091	2698														
85	744	1.2	I	20.67	1072	2698														
71	893	1.2	I	24.80	1054	2698														
62	1017	0.9	*	28.24	1037	2698														
471	134	12.0	III	3.72	1487	2502	SK 92372.1 or SK 93372.1	80 L/4	80 LH/4	80LP/4	50	98								
406	155	10.6	III	4.31	1487	2671						50	118							
341	185	8.9	III	5.13	1487	2898														
300	210	8.0	III	5.83	1487	3085														
263	240	7.6	III	6.67	1486	3303														
250	252	7.0	III	7.01	1486	3363														
214	295	6.2	III	8.19	1485	3372														
192	328	5.9	III	9.11	1484	3372														
171	368	4.4	III	10.22	1483	3372														
169	372	5.2	III	10.33	1483	3372														
156	403	4.8	III	11.20	1482	3372														





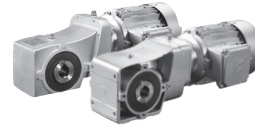

(AGMA Class I =  $f_B$  1.0 - 1.39 II =  $f_B$  1.4 - 1.99 III =  $f_B$   $\geq$  2.0)

(Model type in blue is an energy efficient motor)  
(Model type in light blue is a premium efficient motor)

# 1.0 hp Gearmotors



GEARMOTORS

Motor Power $P_n$ [hp]	Output Speed $n_2$ [rpm]	Output Torque $T_2$ [lb-in]	Service Factor $f_B$	AGMA Class	Gear Ratio $i_{tot}$	Standard Bearings		Model Type	Gearmotor Type			Weight  [lb]	Dim. Page					
						$F_R$ OHL [lb]	$F_A$ Thrust [lb]		Std. Eff. 	Energy Eff. 	Prem. Eff. 							
1.0	139	453	3.6	III	12.56	1481	3372	SK 92372.1 or SK 93372.1	80 L/4	80 LH/4	80LP/4	50	98					
	124	509	3.8	III	14.12	1479	3372					50	118					
	110	571	2.9	III	15.84	1476	3372											
	95	660	2.5	III	18.33	1472	3372											
	87	722	2.7	III	20.04	1469	3372											
	78	810	2.0	III	22.49	1464	3372											
	70	902	2.1	III	25.06	1458	3372											
	62	1012	1.6	II	28.11	1450	3372											
	53	1181	1.5	II	32.80	1436	3372											
	48	1325	1.2	I	36.80	1422	3372											
	42	1493	1.1	I	41.46	1404	3372											
		310	203	13.5	III	5.64	1904					3789	SK 92672.1 or SK 93672.1	80 L/4	80 LH/4	80LP/4	75	102
		235	268	11.5	III	7.44	1903					4353					75	122
	210	300	10.3	III	8.33	1903	4496											
	186	338	9.3	III	9.39	1902	4496											
	172	366	8.8	III	10.16	1902	4496											
	154	410	7.8	III	11.39	1901	4496											
	136	462	6.9	III	12.84	1900	4496											
	121	519	5.4	III	14.40	1899	4496											
	112	561	5.7	III	15.56	1898	4496											
	100	629	4.5	III	17.46	1897	4496											
	88	720	3.8	III	20.00	1894	4496											
	64	984	3.3	III	27.33	1885	4496											
	57	1104	2.5	III	30.67	1880	4496											
	52	1214	2.6	III	33.71	1875	4496											
	46	1362	2.1	III	37.82	1867	4496											
	40	1559	1.7	II	43.28	1855	4496											
	36	1749	1.6	II	48.56	1842	4496											
	198	319	15.4	III	8.85	2351	5620	SK 92772.1 or SK 93772.1	80 L/4	80 LH/4	80LP/4	100	106					
	155	406	12.5	III	11.28	2350	5620					100	126					
	140	450	11.7	III	12.50	2349	5620											
	127	497	10.8	III	13.79	2349	5620											
	113	555	10.1	III	15.42	2348	5620											
	102	615	9.3	III	17.08	2347	5620											
	93	679	8.3	III	18.84	2346	5620											
	91	690	8.1	III	19.17	2346	5620											
	83	761	7.3	III	21.14	2345	5620											
	77	813	7.1	III	22.59	2344	5620											
	71	887	6.5	III	24.64	2342	5620											
	69	913	6.1	III	25.34	2341	5620											
	63	996	5.6	III	27.65	2339	5620											
	40	1565	3.6	III	43.44	2321	5620											
	37	1690	2.7	III	46.92	2316	5620											
	33	1896	2.7	III	52.64	2307	5620											
	29	2149	1.8	II	59.68	2294	5620											
	26	2411	1.8	II	66.96	2278	5620											

(Model type in blue is an energy efficient motor)  
(Model type in light blue is a premium efficient motor)

(AGMA Class I =  $f_B$  1.0 - 1.39 II =  $f_B$  1.4 - 1.99 III =  $f_B$   $\geq$  2.0)



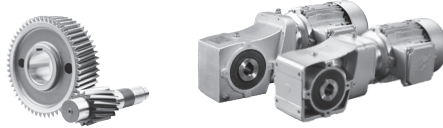

Motor Power $P_n$ [hp]	Output Speed $n_2$ [rpm]	Output Torque $T_2$ [lb-in]	Service Factor $f_B$	AGMA Class	Gear Ratio $i_{tot}$	Standard Bearings		Model Type	Gearmotor Type			Weight  [lb]	Dim. Page
						$F_R$ OHL [lb]	$F_A$ Thrust [lb]		Std. Eff. 	Energy Eff. 	Prem. Eff. 		
1.5	486	195	3.0	III	3.58	818	1475	SK 92072.1 or SK 93072.1	90 S/4	90 SH/4	90 SP/4	47	90
	438	216	2.8	III	3.97	842	1546						
	374	253	2.3	III	4.65	877	1649						
	337	281	2.1	III	5.17	901	1694						
	299	317	2.0	III	5.83	929	1749						
	486	195	4.0	III	3.58	1016	1682	SK 92172.1 or SK 93172.1	90 S/4	90 SH/4	90 SP/4	51	94
	452	209	3.8	III	3.85	1037	1734						
	405	233	4.0	III	4.30	1070	1822						
	356	266	3.6	III	4.89	1107	1933						
	331	286	3.3	III	5.26	1106	1997						
	302	313	2.6	III	5.77	1105	2089						
	267	355	2.3	III	6.53	1103	2168						
	251	377	2.6	III	6.94	1102	2203						
	222	426	2.3	III	7.83	1099	2279						
	209	453	2.2	III	8.33	1098	2315						
	183	516	1.8	II	9.49	1093	2396						
	468	202	7.9	III	3.72	1487	2468	SK 92372.1 or SK 93372.1	90 S/4	90 SH/4	90 SP/4	61	98
	404	234	7.0	III	4.31	1486	2631						
	339	279	5.9	III	5.13	1485	2848						
	298	317	5.3	III	5.83	1484	3026						
261	362	5.0	III	6.67	1483	3233							
248	381	4.7	III	7.01	1483	3303							
212	445	4.1	III	8.19	1481	3372							
191	495	3.9	III	9.11	1479	3372							
170	555	2.9	III	10.22	1477	3372							
168	561	3.5	III	10.33	1477	3372							
155	608	3.2	III	11.20	1475	3372							
138	683	2.4	III	12.56	1471	3372							
123	767	2.5	III	14.12	1466	3372							
110	861	1.9	II	15.84	1461	3372							
95	996	1.6	II	18.33	1451	3372							
87	1089	1.8	II	20.04	1444	3372							
77	1222	1.3	I	22.49	1432	3372							
69	1361	1.4	II	25.06	1419	3372							
62	1527	1.1	I	28.11	1400	3372							
53	1782	1.0	I	32.80	1367	3372							
47	1999	0.8	*	36.80	1334	3372							





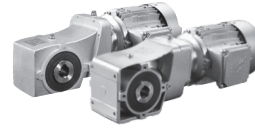

(AGMA Class I =  $f_B$  1.0 - 1.39 II =  $f_B$  1.4 - 1.99 III =  $f_B$   $\geq$  2.0)

(Model type in blue is an energy efficient motor)  
(Model type in light blue is a premium efficient motor)

# 1.5 hp Gearmotors



GEARMOTORS

Motor Power $P_n$ [hp]	Output Speed $n_2$ [rpm]	Output Torque $T_2$ [lb-in]	Service Factor $f_B$	AGMA Class	Gear Ratio $i_{tot}$	Standard Bearings		Model Type	Gearmotor Type			Weight  [lb]	Dim. Page
						$F_R$ OHL [lb]	$F_A$ Thrust [lb]		Std. Eff. 	Energy Eff. 	Prem. Eff. 		
1.5	399	237	11.8	III	4.36	1903	3336	SK 92672.1 or SK 93672.1	90 S/4	90 SH/4	90 SP/4	85	102
	308	306	9.0	III	5.64	1903	3753						
	260	363	7.7	III	6.68	1902	4086						
	234	404	7.6	III	7.44	1901	4302						
	209	453	6.8	III	8.33	1900	4485						
	185	510	6.2	III	9.39	1899	4496						
	171	552	5.8	III	10.16	1898	4496						
	153	619	5.2	III	11.39	1897	4496						
	136	698	4.6	III	12.84	1895	4496						
	121	783	3.6	III	14.40	1892	4496						
	112	846	3.8	III	15.56	1890	4496						
	100	949	3.0	III	17.46	1886	4496						
	96	989	3.1	III	18.21	1885	4496						
	87	1087	2.5	III	20.00	1881	4496						
	70	1352	2.4	III	24.88	1868	4496						
	64	1485	2.2	III	27.33	1860	4496						
	57	1666	1.7	II	30.67	1848	4496						
	52	1832	1.8	II	33.71	1836	4496						
	46	2055	1.4	I	37.82	1818	4496						
	40	2351	1.2	I	43.28	1790	4496						
36	2638	1.1	I	48.56	1759	4496							
340	278	16.1	III	5.12	2351	4518	SK 92772.1 or SK 93772.1	90 S/4	90 SH/4	90 SP/4	110	106	
242	390	12.4	III	7.18	2350	5301							
197	481	10.2	III	8.85	2349	5620							
177	533	9.6	III	9.81	2348	5620							
154	613	8.3	III	11.28	2347	5620							
139	679	7.8	III	12.50	2346	5620							
126	749	7.1	III	13.79	2345	5620							
113	838	6.7	III	15.42	2343	5620							
102	928	6.2	III	17.08	2341	5620							
92	1024	5.5	III	18.84	2339	5620							
91	1041	5.4	III	19.17	2338	5620							
82	1149	4.9	III	21.14	2335	5620							
77	1227	4.7	III	22.59	2333	5620							
71	1339	4.3	III	24.64	2329	5620							
69	1377	4.0	III	25.34	2328	5620							
63	1502	3.7	III	27.65	2324	5620							
50	1904	3.1	III	35.04	2306	5620							
44	2136	2.6	III	39.32	2294	5620							
40	2360	2.4	III	43.44	2281	5620							
37	2549	1.8	II	46.92	2269	5620							
33	2860	1.8	II	52.64	2248	5620							
29	3242	1.2	I	59.68	2217	5620							
26	3638	1.2	I	66.96	2181	5620							

(Model type in blue is an energy efficient motor)

(Model type in light blue is a premium efficient motor)

(AGMA Class I =  $f_B$  1.0 - 1.39 II =  $f_B$  1.4 - 1.99 III =  $f_B$   $\geq$  2.0)



Motor Power $P_n$ [hp]	Output Speed $n_2$ [rpm]	Output Torque $T_2$ [lb-in]	Service Factor $f_B$	AGMA Class	Gear Ratio $i_{tot}$	Standard Bearings		Model Type	Gearmotor Type			Weight  [lb]	Dim. Page								
						$F_R$ OHL [lb]	$F_A$ Thrust [lb]		Std. Eff. 	Energy Eff. 	Prem. Eff. 										
2.0	487	259	3.0	III	3.58	995	1634	SK 92172.1 or SK 93172.1	90 L/4	90 LH/4	90 LP/4	54	94								
	454	278	2.8	III	3.85	1015	1681						54	114							
	406	310	3.0	III	4.30	1045	1764														
	357	353	2.7	III	4.89	1081	1866														
	332	380	2.5	III	5.26	1102	1924														
	302	417	2.0	II	5.77	1100	2008														
	267	472	1.7	II	6.53	1096	2090														
	251	502	1.9	II	6.94	1094	2120														
	223	566	1.7	II	7.83	1089	2188														
	209	602	1.7	II	8.33	1086	2218														
	184	686	1.4	I	9.49	1078	2287														
	469	269	6.0	III	3.72	1477	2426								SK 92372.1 or SK 93372.1	90 L/4	90 LH/4	90 LP/4	65	98	
	405	311	5.3	III	4.31	1485	2581													65	118
	340	370	4.4	III	5.13	1483	2787														
	299	421	4.0	III	5.83	1482	2955														
	262	482	3.8	III	6.67	1480	3149														
249	506	3.5	III	7.01	1479	3234															
213	592	3.1	III	8.19	1475	3363															
192	658	2.9	III	9.11	1472	3372															
171	738	2.2	III	10.22	1468	3372															
169	746	2.6	III	10.33	1468	3372															
156	809	2.4	III	11.20	1464	3372															
139	908	1.8	II	12.56	1458	3372															
124	1020	1.9	II	14.12	1450	3372															
110	1145	1.4	II	15.84	1439	3372															
95	1324	1.2	I	18.33	1423	3372															
87	1448	1.3	I	20.04	1409	3372															
78	1624	1.0	I	22.49	1388	3372															
70	1810	1.1	I	25.06	1363	3372															
62	2031	0.8	*	28.11	1329	3372															
400	315	8.9	III	4.36	1903	3298	SK 92672.1 or SK 93672.1	90 L/4	90 LH/4	90 LP/4	89	102									
309	407	6.7	III	5.64	1901	3701						89	122								
261	483	5.8	III	6.68	1900	4027															
235	537	5.8	III	7.44	1899	4231															
209	602	5.1	III	8.33	1897	4419															
186	679	4.6	III	9.39	1895	4496															
172	734	4.4	III	10.16	1894	4496															
153	823	3.9	III	11.39	1891	4496															
136	927	3.5	III	12.84	1887	4496															
121	1040	2.7	III	14.40	1883	4496															
112	1124	2.9	III	15.56	1879	4496															
100	1261	2.2	III	17.46	1872	4496															
96	1315	2.3	III	18.21	1870	4496															
87	1445	1.9	II	20.00	1862	4496															
70	1797	1.8	II	24.88	1839	4496															
64	1974	1.6	II	27.33	1825	4496															
57	2215	1.3	I	30.67	1803	4496															
52	2435	1.3	I	33.71	1782	4496															
46	2732	1.0	I	37.82	1748	4496															





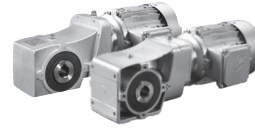

(AGMA Class I =  $f_B$  1.0 - 1.39 II =  $f_B$  1.4 - 1.99 III =  $f_B$   $\geq$  2.0)

(Model type in blue is an energy efficient motor)  
(Model type in light blue is a premium efficient motor)

# 2.0, 3.0 hp Gearmotors



GEARMOTORS

Motor Power $P_n$ [hp]	Output Speed $n_2$ [rpm]	Output Torque $T_2$ [lb-in]	Service Factor $f_B$	AGMA Class	Gear Ratio $i_{tot}$	Standard Bearings		Model Type	Gearmotor Type			Weight  [lb]	Dim. Page						
						$F_R$ OHL [lb]	$F_A$ Thrust [lb]		Std. Eff. 	Energy Eff. 	Prem. Eff. 								
2.0	341	370	12.1	III	5.12	2350	4471	SK 92772.1 or SK 93772.1	90 L/4	90 LH/4	90 LP/4	114	106						
	243	519	9.3	III	7.18	2348	5231												
	197	639	7.7	III	8.85	2347	5620												
	178	709	7.2	III	9.81	2346	5620												
	155	815	6.2	III	11.28	2344	5620												
	140	903	5.8	III	12.50	2342	5620												
	127	996	5.4	III	13.79	2339	5620												
	113	1114	5.0	III	15.42	2336	5620												
	102	1234	4.6	III	17.08	2333	5620												
	93	1361	4.2	III	18.84	2329	5620												
	91	1385	4.0	III	19.17	2328	5620												
	83	1527	3.7	III	21.14	2323	5620												
	77	1632	3.5	III	22.59	2318	5620												
	71	1780	3.3	III	24.64	2312	5620												
	69	1831	3.0	III	25.34	2310	5620												
	63	1997	2.8	III	27.65	2302	5620												
	50	2531	2.3	III	35.04	2271	5620												
	44	2840	2.0	II	39.32	2249	5620												
	40	3138	1.8	II	43.44	2226	5620												
	37	3389	1.3	I	46.92	2204	5620												
33	3803	1.3	I	52.64	2164	5620													
3.0	475	398	4.0	III	3.72	1438	2337	SK 92372.1 or SK 93372.1	100 L/4	100 LH/4	100 LP/4	84	98						
	410	461	3.6	III	4.31	1480	2477												
	344	549	3.0	III	5.13	1477	2660												
	303	625	2.7	III	5.83	1474	2808												
	265	714	2.5	III	6.67	1469	2977												
	252	751	2.4	III	7.01	1467	3061												
	215	878	2.1	III	8.19	1460	3194												
	194	976	2.0	II	9.11	1453	3295												
	173	1095	1.5	II	10.22	1444	3372												
	158	1200	1.6	II	11.20	1435	3372												
	140	1346	1.2	I	12.56	1420	3372												
	405	467	6.0	III	4.36	1900	3213							SK 92672.1 or SK 93672.1	100 L/4	100 LH/4	100 LP/4	108	102
	313	604	4.5	III	5.64	1897	3590												
	264	716	3.9	III	6.68	1894	3900												
	237	797	3.9	III	7.44	1892	4079												
	212	893	3.5	III	8.33	1889	4282												
	188	1006	3.1	III	9.39	1884	4425												
	174	1089	3.0	III	10.16	1881	4496												
	155	1220	2.6	III	11.39	1874	4496												
	137	1375	2.3	III	12.84	1866	4496												
123	1543	1.8	II	14.40	1856	4496													
113	1667	1.9	II	15.56	1848	4496													
101	1871	1.5	II	17.46	1833	4496													
97	1950	1.6	II	18.21	1827	4496													
71	2665	1.2	I	24.88	1756	4496													

(Model type in blue is an energy efficient motor)  
(Model type in light blue is a premium efficient motor)

(AGMA Class I =  $f_B$  1.0 - 1.39 II =  $f_B$  1.4 - 1.99 III =  $f_B$   $\geq$  2.0)

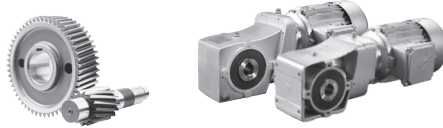

# 3.0, 5.0 hp Gearmotors

Motor Power $P_n$ [hp]	Output Speed $n_2$ [rpm]	Output Torque $T_2$ [lb-in]	Service Factor $f_B$	AGMA Class	Gear Ratio $i_{tot}$	Standard Bearings		Model Type	Gearmotor Type			Weight  [lb]	Dim. Page				
						$F_R$ OHL [lb]	$F_A$ Thrust [lb]		Std. Eff. 	Energy Eff. 	Prem. Eff. 						
3.0	345	548	8.2	III	5.12	2348	4366	SK 92772.1 or SK 93772.1	100 L/4	100 LH/4	100 LP/4	133	106				
	246	769	6.3	III	7.18	2344	5080										
	200	948	5.2	III	8.85	2341	5620					133	126				
	180	1051	4.9	III	9.81	2338	5620										
	156	1209	4.2	III	11.28	2334	5620										
	141	1339	3.9	III	12.50	2329	5620										
	128	1477	3.6	III	13.79	2324	5620										
	114	1652	3.4	III	15.42	2318	5620										
	103	1830	3.1	III	17.08	2310	5620										
	94	2019	2.8	III	18.84	2301	5620										
	92	2053	2.7	III	19.17	2299	5620										
	83	2265	2.5	III	21.14	2287	5620										
	78	2420	2.4	III	22.59	2278	5620										
	70	2715	2.1	III	25.34	2258	5620										
	62	3041	1.8	II	28.38	2234	5620										
	55	3412	1.6	II	31.85	2202	5620										
	50	3754	1.6	II	35.04	2169	5620										
45	4212	1.3	I	39.32	2120	5620											
5.0	476	662	2.4	III	3.72	1368	2180	SK 92372.1 or SK 93372.1	100 LA/4	112 MH/4	100 AP/4	106	98				
	411	767	2.1	III	4.31	1419	2293										
	345	913	1.8	II	5.13	1457	2435					106	118				
	303	1039	1.6	II	5.83	1448	2547										
	266	1187	1.5	II	6.67	1436	2669										
	253	1248	1.4	II	7.01	1430	2746										
	216	1459	1.3	I	8.19	1408	2876										
	194	1622	1.2	I	9.11	1389	2956										
	173	1820	0.9	*	10.22	1362	3015										
	158	1994	1.0	I	11.20	1335	3034										
	406	776	3.6	III	4.36	1855	3073					SK 92672.1 or SK 93672.1	100 LA/4	112 MH/4	100 AP/4	130	102
	314	1004	2.7	III	5.64	1884	3404										
	265	1190	2.4	III	6.68	1876	3689									130	122
	238	1324	2.3	III	7.44	1869	3822										
	212	1484	2.1	III	8.33	1860	4022										
	188	1672	1.9	II	9.39	1848	4146										
	174	1809	1.8	II	10.16	1838	4259										
155	2028	1.6	II	11.39	1820	4321											
138	2286	1.4	II	12.84	1797	4476											
123	2564	1.1	I	14.40	1768	4496											
114	2771	1.2	I	15.56	1744	4496											
101	3109	0.9	*	17.46	1700	4496											



(AGMA Class I =  $f_B$  1.0 - 1.39 II =  $f_B$  1.4 - 1.99 III =  $f_B$   $\geq$  2.0)

(Model type in blue is an energy efficient motor)  
(Model type in light blue is a premium efficient motor)



# 5.0, 7.5, 10 hp Gearmotors

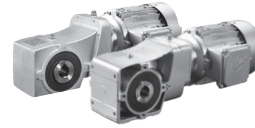

GEARMOTORS

Motor Power $P_n$ [hp]	Output Speed $n_2$ [rpm]	Output Torque $T_2$ [lb-in]	Service Factor $f_B$	AGMA Class	Gear Ratio $i_{tot}$	Standard Bearings		Model Type	Gearmotor Type			Weight  [lb]	Dim. Page
						$F_R$ OHL [lb]	$F_A$ Thrust [lb]		Std. Eff. 	Energy Eff. 	Prem. Eff. 		
5.0	346	911	4.9	III	5.12	2341	4199	SK 92772.1 or SK 93772.1	100 LA/4	112 MH/4	100 AP/4	155	106
	247	1278	3.8	III	7.18	2331	4831					155	126
	200	1575	3.1	III	8.85	2321	5300						
	180	1747	2.9	III	9.81	2313	5533						
	157	2009	2.5	III	11.28	2301	5620						
	142	2225	2.4	III	12.50	2289	5620						
	128	2455	2.2	III	13.79	2276	5620						
	115	2745	2.0	III	15.42	2256	5620						
	104	3041	1.9	II	17.08	2234	5620						
	94	3355	1.7	II	18.84	2207	5620						
	92	3412	1.6	II	19.17	2202	5620						
	84	3764	1.5	II	21.14	2168	5620						
	78	4022	1.4	II	22.59	2141	5620						
70	4512	1.2	I	25.34	2083	5620							
7.5	408	1158	2.4	III	4.36	1759	2898	SK 92672.1 or SK 93672.1	132 S/4	132 SH/4	132 SP/4	173	102
	316	1498	1.8	II	5.64	1859	3172					173	122
	266	1775	1.6	II	6.68	1840	3426						
	239	1975	1.6	II	7.44	1825	3504						
	214	2213	1.4	I	8.33	1804	3657						
	175	2699	1.2	I	10.16	1752	3904						
	427	1106	4.0	III	4.17	2285	3701	SK 92772.1 or SK 93772.1	132 S/4	132 SH/4	132 SP/4	198	106
	348	1359	3.3	III	5.12	2329	3989					198	126
	279	1697	2.6	III	6.39	2316	4365						
	248	1907	2.5	III	7.18	2306	4523						
	201	2349	2.1	III	8.85	2282	4902						
	181	2606	2.0	II	9.81	2266	5152						
	158	2996	1.7	II	11.28	2237	5281						
142	3319	1.6	II	12.50	2210	5375							
115	4095	1.4	I	15.42	2133	5614							
104	4537	1.3	I	17.08	2080	5620							
93	5090	1.1	I	19.17	2004	5620							
10	406	1552	1.8	II	4.36	1668	2735	SK 92672.1 or SK 93672.1	132 M/4	132 MH/4	132 MP/4	189	102
	314	2009	1.4	I	5.64	1742	2954					189	122
	265	2380	1.2	I	6.68	1779	3180						
	238	2648	1.2	I	7.44	1758	3204						
	212	2967	1.0	I	8.33	1719	3312						
	174	3619	0.9	*	10.16	1621	3555						
	425	1484	3.0	III	4.17	2214	3549	SK 92772.1 or SK 93772.1	132 M/4	132 MH/4	132 MP/4	214	106
	346	1823	2.5	III	5.12	2310	3796					214	126
	277	2275	1.9	II	6.39	2286	4127						
	247	2556	1.9	II	7.18	2269	4236						
	200	3150	1.6	II	8.85	2225	4533						
	180	3494	1.5	II	9.81	2195	4745						
	157	4017	1.3	I	11.28	2142	4877						
142	4451	1.2	I	12.50	2091	4927							
115	5490	1.0	I	15.42	1941	5082							
104	6083	0.9	*	17.08	1834	5102							
92	6825	0.8	*	19.17	1675	5140							

(Model type in blue is an energy efficient motor)

(Model type in light blue is a premium efficient motor)

(AGMA Class I =  $f_B$  1.0 - 1.39 II =  $f_B$  1.4 - 1.99 III =  $f_B$   $\geq$  2.0)

# 92.1/93.1 Series Reducers & Combinations

## Speed Reducer Selections

- SK92072.1  
SK93072.1
- SK92172.1  
SK93172.1
- SK92372.1  
SK93372.1
- SK92672.1  
SK93672.1
- SK92772.1  
SK93772.1

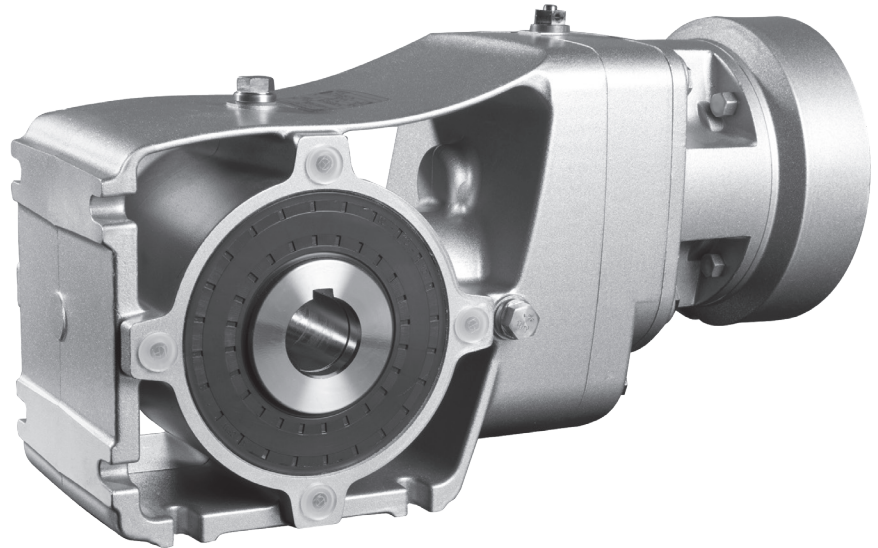

[www.nord.com](http://www.nord.com)

Model Type	Gear Ratio	Output Speed	Output Torque
	$i_{tot}$	$n_2$	$T_{2,max}$
		1750 rpm	
		[rpm]	[lb-in]
SK 92072.1	17.42	100	3806
	19.22	91	3806
	21.32	82	3806
	23.79	74	3806
	26.77	65	3806
	30.93	57	3894
	34.80	50	3894
	38.02	46	3983
	42.18	41	3983
	43.40	40	3983
47.95	36	3983	

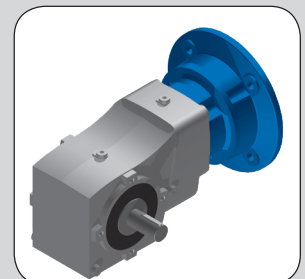
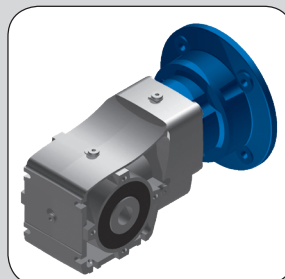

# SK 92072.1 / SK 93072.1 NEMA-C + W Ratings & Combinations



Model Type	Gear Ratio $i_{tot}$	Output Speed $n_2$ [rpm]	Output Torque $T_{2max}$ [lb-in]	Maximum input power <sup>◇</sup>			Input Shaft  W	NEMA C-Face <sup>^</sup> Available Combinations			
				[hp]	[hp]	[hp]		56C	140TC	180TC	210TC
SK 92072.1	3.58	489	584	<i>1.50</i>	<i>0.99</i>	<i>0.75</i>	X	X	X*		
SK 93072.1	3.97	440	602	<i>1.50</i>	<i>0.99</i>	<i>0.75</i>	X	X	X*		
	4.65	376	575	<i>1.50</i>	<i>0.99</i>	<i>0.75</i>	X	X	X*		
	5.17	339	593	<i>1.50</i>	<i>0.99</i>	<i>0.75</i>	X	X	X*		
	5.83	300	637	<i>1.50</i>	<i>0.99</i>	<i>0.75</i>	X	X	X*		
	6.67	262	602	<i>1.50</i>	<i>0.99</i>	<i>0.75</i>	X	X	X*		
	7.58	231	637	<i>1.50</i>	<i>0.99</i>	<i>0.75</i>	X	X	X*		
	8.67	202	655	<i>1.50</i>	<i>0.99</i>	<i>0.75</i>	X	X	X*		
	9.85	178	673	<i>1.50</i>	<i>0.99</i>	<i>0.75</i>	X	X	X*		
	11.11	158	575	<i>1.44</i>	<i>0.94</i>	<i>0.72</i>	X	X	X*		
	12.78	137	522	<i>1.13</i>	<i>0.75</i>	<i>0.57</i>	X	X	X*		
	16.00	109	584	<i>1.01</i>	<i>0.67</i>	<i>0.51</i>	X	X	X*		
	18.52	95	531	<i>0.80</i>	<i>0.52</i>	<i>0.40</i>	X	X*	X*		
	20.80	84	717	<i>0.96</i>	<i>0.63</i>	<i>0.48</i>	X	X*	X*		
	24.07	73	699	<i>0.81</i>	<i>0.53</i>	<i>0.40</i>	X	X*	X*		
	27.16	64	575	<i>0.59</i>	<i>0.39</i>	<i>0.29</i>	X	X*	X*		
	31.57	55	575	<i>0.51</i>	<i>0.33</i>	<i>0.25</i>	X	X*	X*		
	35.62	49	575	<i>0.45</i>	<i>0.29</i>	<i>0.22</i>	X	X*	X*		
	40.98	43	522	<i>0.35</i>	<i>0.23</i>	<i>0.18</i>	X	X*	X*		
	47.67	37	407	<i>0.24</i>	<i>0.16</i>	<i>0.12</i>	X	X*	X*		
	53.78	33	460	<i>0.24</i>	<i>0.16</i>	<i>0.12</i>	X	X*	X*		
	61.88	28	522	<i>0.23</i>	<i>0.15</i>	<i>0.12</i>	X	X*	X*		
Based upon 1750 rpm Input Speed				1750 rpm	1150 rpm	875 rpm	-	1 hp	2 hp	5 hp	10 hp
								C-face Adapter Maximum Input Power <sup>^</sup>			

◇ The maximum input power limit shown is the largest motor power typically combined with the gear unit. *The Italicized power values shown are not the mechanical limit and often may be increased through discussion with our sales or engineering department.*

<sup>^</sup> The NEMA C-face power limit must also be considered when selecting a reducer. The C-face Adapter's Maximum Input Power values are displayed under the Available Combinations and based on a 1750 rpm motor.

\* Caution - The motor power may exceed the gear unit's mechanical torque capacity

	W	56C	140TC
SK 92072.1	15	14	14
SK 93072.1	15	14	14

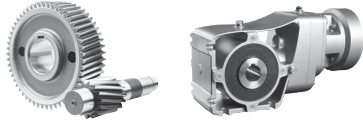

# SK 92172.1 / SK 93172.1 NEMA-C + W Ratings & Combinations

Model Type	Gear Ratio $i_{tot}$	Output Speed $n_2$ [rpm]	Output Torque* $T_{2max}$ [lb-in]	Maximum input power <sup>◇</sup>			Input Shaft W	NEMA C-Face <sup>^</sup> Available Combinations			
				[hp]	[hp]	[hp]		56C	140TC	180TC	210TC
SK 92172.1	3.58	489	779	2.00	1.31	1.00	X	X	X		
SK 93172.1	3.85	455	788	2.00	1.31	1.00	X	X	X		
	4.30	407	938	2.00	1.31	1.00	X	X	X		
	4.89	358	947	2.00	1.31	1.00	X	X	X		
	5.26	333	947	2.00	1.31	1.00	X	X	X		
	5.77	303	814	2.00	1.31	1.00	X	X	X		
	6.53	268	823	2.00	1.31	1.00	X	X	X		
	6.94	252	974	2.00	1.31	1.00	X	X	X		
	7.83	223	982	2.00	1.31	1.00	X	X	X		
	8.33	210	1018	2.00	1.31	1.00	X	X	X		
	9.03	194	832	2.00	1.31	1.00	X	X	X		
	9.49	184	947	2.00	1.31	1.00	X	X	X		
	10.15	172	841	2.00	1.31	1.00	X	X	X		
	10.83	162	1000	2.00	1.31	1.00	X	X	X		
	12.18	144	1009	2.00	1.31	1.00	X	X	X		
	12.34	142	956	2.00	1.31	1.00	X	X	X		
	13.87	126	956	1.91	1.26	0.96	X	X	X*		
	15.23	115	823	1.50	0.99	0.75	X	X	X*		
	20.67	85	920	1.24	0.81	0.62	X	X	X*		
	24.80	71	1062	1.19	0.78	0.59	X	X	X*		
	28.24	62	956	0.94	0.62	0.47	X	X*	X*		
	31.00	56	956	0.86	0.56	0.43	X	X*	X*		
	35.31	50	956	0.75	0.49	0.38	X	X*	X*		
	37.14	47	797	0.60	0.39	0.30	X	X*	X*		
	38.75	45	823	0.59	0.39	0.29	X	X*	X*		
	42.30	41	912	0.60	0.39	0.30	X	X*	X*		
	46.43	38	823	0.49	0.32	0.25	X	X*	X*		
	56.00	31	522	0.26	0.17	0.13	X	X*	X*		
	63.78	27	593	0.26	0.17	0.13	X	X*	X*		
	70.00	25	646	0.26	0.17	0.13	X	X*	X*		
	Based upon 1750 rpm			1750 rpm	1150 rpm	875 rpm	-	1 hp	2 hp	5 hp	10 hp
	Input Speed			Input Speed				C-face Adapter Maximum Input Power ^			



- ◇ The maximum input power limit shown is the largest motor power typically combined with the gear unit. *The Italicized power values shown are not the mechanical limit and often may be increased through discussion with our sales or engineering department.*
- ^ The NEMA C-face power limit must also be considered when selecting a reducer. The C-face Adapter's Maximum Input Power values are displayed under the Available Combinations and based on a 1750 rpm motor.
- \* Caution - The motor power may exceed the gear unit's mechanical torque capacity

	W	56C	140TC
SK 92172.1	19	18	18
SK 93172.1	19	18	18

# SK 92372.1 / SK 93372.1 NEMA-C + W Ratings & Combinations



Model Type	Gear Ratio $i_{tot}$	Output Speed $n_2$ [rpm]	Output Torque* $T_{2max}$ [lb-in]	Maximum input power <sup>◇</sup>			Input Shaft  W	NEMA C-Face <sup>^</sup> Available Combinations			
				[hp]	[hp]	[hp]		56C	140TC	180TC	210TC
SK 92372.1	3.72	471	1602	5.00	3.29	2.50	X	X	X	X	
SK 93372.1	4.31	406	1646	5.00	3.29	2.50	X	X	X	X	
	5.13	341	1637	5.00	3.29	2.50	X	X	X	X	
	5.83	300	1673	5.00	3.29	2.50	X	X	X	X	
	6.67	263	1814	5.00	3.29	2.50	X	X	X	X	
	7.01	250	1779	5.00	3.29	2.50	X	X	X	X	
	8.19	214	1841	5.00	3.29	2.50	X	X	X	X	
	9.11	192	1929	5.00	3.29	2.50	X	X	X	X	
	10.22	169	1629	4.38	2.88	2.19	X	X	X	X*	
	10.33	171	1947	5.00	3.29	2.50	X	X	X	X	
	11.20	156	1929	4.78	3.14	2.39	X	X	X	X*	
	12.56	139	1629	3.60	2.36	1.80	X	X	X	X*	
	14.12	124	1929	3.79	2.49	1.90	X	X	X	X*	
	15.84	110	1629	2.85	1.88	1.43	X	X	X	X*	
	18.33	95	1620	2.45	1.61	1.23	X	X	X		
	20.04	87	1938	2.69	1.76	1.34	X	X	X	X*	
	22.49	78	1629	2.01	1.32	1.01	X	X	X	X*	
	25.06	70	1938	2.15	1.41	1.07	X	X	X		
	28.11	62	1629	1.61	1.06	0.80	X	X	X*		
	32.80	53	1752	1.48	0.97	0.74	X	X	X*		
	36.80	48	1629	1.23	0.81	0.61	X	X	X*		
	41.46	42	1629	1.09	0.72	0.55	X	X	X*		
	46.64	38	1629	0.97	0.64	0.48	X	X*	X*		
	49.46	35	1248	0.70	0.46	0.35	X	X*	X*		
	55.49	32	1398	0.70	0.46	0.35	X	X*	X*		
Based upon 1750 rpm Input Speed				1750 rpm	1150 rpm	875 rpm	-	1 hp	2 hp	5 hp	10 hp
				Input Speed				C-face Adapter Maximum Input Power ^			

◇ The maximum input power limit shown is the largest motor power typically combined with the gear unit. *The italicized power values shown are not the mechanical limit and often may be increased through discussion with our sales or engineering department.*

^ The NEMA C-face power limit must also be considered when selecting a reducer. The C-face Adapter's Maximum Input Power values are displayed under the Available Combinations and based on a 1750 rpm motor.

\* Caution - The motor power may exceed the gear unit's mechanical torque capacity

	W	56C	140TC	180TC
SK 92372.1	31	29	29	31
SK 93372.1	31	29	29	31

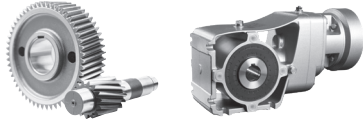

# SK 92672.1 / SK 93672.1 NEMA-C + W Ratings & Combinations

Model Type	Gear Ratio $i_{tot}$	Output Speed $n_2$ [rpm]	Output Torque* $T_{2max}$ [lb-in]	Maximum input power <sup>◇</sup>			Input Shaft W	NEMA C-Face <sup>^</sup> Available Combinations			
				[hp]	[hp]	[hp]		56C	140TC	180TC	210TC
SK 92672.1	4.36	401	2788	<i>10.00</i>	<i>6.57</i>	<i>5.00</i>	X	X	X	X	X
SK 93672.1	5.64	310	2744	<i>10.00</i>	<i>6.57</i>	<i>5.00</i>	X	X	X	X	X
	6.68	262	2806	<i>10.00</i>	<i>6.57</i>	<i>5.00</i>	X	X	X	X	X
	7.44	235	3089	<i>10.00</i>	<i>6.57</i>	<i>5.00</i>	X	X	X	X	X
	8.33	210	3098	<i>10.00</i>	<i>6.57</i>	<i>5.00</i>	X	X	X	X	X
	9.39	186	3142	9.29	6.10	4.64	X	X	X	X	X
	10.16	172	3213	8.78	5.77	4.39	X	X	X	X	X*
	11.39	154	3195	7.79	5.12	3.89	X	X	X	X	
	12.84	136	3213	6.95	4.57	3.47	X	X	X	X	
	14.40	121	2806	5.41	3.55	2.70	X	X	X	X	
	15.56	112	3213	5.73	3.77	2.87	X	X	X	X	
	17.46	100	2806	4.46	2.93	2.23	X	X	X	X*	
	18.21	96	3089	4.71	3.10	2.36	X	X	X	X*	
	20.00	88	2753	3.82	2.51	1.91	X	X	X		
	24.88	70	3213	3.59	2.36	1.79	X	X	X	X*	
	27.33	64	3222	3.27	2.15	1.64	X	X	X		
	30.67	57	2815	2.55	1.67	1.27	X	X	X		
	33.71	52	3213	2.65	1.74	1.32	X	X	X		
	37.82	46	2815	2.07	1.36	1.03	X	X	X		
	43.28	40	2708	1.74	1.14	0.87	X	X	X*		
	48.56	36	2815	1.61	1.06	0.80	X	X	X*		
Based upon 1750 rpm Input Speed				1750 rpm	1150 rpm	875 rpm	-	1 hp	2 hp	5 hp	10 hp
				Input Speed				C-face Adapter Maximum Input Power ^			



- ◇ The maximum input power limit shown is the largest motor power typically combined with the gear unit. *The Italicized power values shown are not the mechanical limit and often may be increased through discussion with our sales or engineering department.*
- ^ The NEMA C-face power limit must also be considered when selecting a reducer. The C-face Adapter's Maximum Input Power values are displayed under the Available Combinations and based on a 1750 rpm motor.
- \* Caution - The motor power may exceed the gear unit's mechanical torque capacity

	W	56C	140TC	180TC	210TC
SK 92672.1	55	53	53	55	29
SK 93672.1	55	53	53	55	29



# SK 92772.1 / SK 93772.1 NEMA-C + W Ratings & Combinations

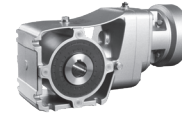

Model Type	Gear Ratio $i_{tot}$	Output Speed $n_2$ [rpm]	Output Torque* $T_{2max}$ [lb-in]	Maximum input power <sup>◆</sup>			Input Shaft  W	NEMA C-Face <sup>^</sup> Available Combinations			
				[hp]	[hp]	[hp]		56C	140TC	180TC	210TC
SK 92772.1	4.17	420	4390	<i>10.00</i>	<i>6.57</i>	<i>5.00</i>	X				X
SK 93772.1	5.12	342	4470	<i>10.00</i>	<i>6.57</i>	<i>5.00</i>	X	X	X	X	X
	6.39	274	4363	<i>10.00</i>	<i>6.57</i>	<i>5.00</i>	X				X
	7.18	244	4833	<i>10.00</i>	<i>6.57</i>	<i>5.00</i>	X	X	X	X	X
	8.85	198	4912	<i>10.00</i>	<i>6.57</i>	<i>5.00</i>	X	X	X	X	X
	9.81	178	5125	<i>10.00</i>	<i>6.57</i>	<i>5.00</i>	X	X	X	X	X
	11.28	155	5089	<i>10.00</i>	<i>6.57</i>	<i>5.00</i>	X	X	X	X	X
	12.50	140	5275	<i>10.00</i>	<i>6.57</i>	<i>5.00</i>	X	X	X	X	X
	13.79	127	5355	<i>10.00</i>	<i>6.57</i>	<i>5.00</i>	X	X	X	X	X
	15.42	113	5585	<i>10.00</i>	<i>6.57</i>	<i>5.00</i>	X	X	X	X	X
	17.08	102	5709	9.28	6.10	4.64	X	X	X	X	X*
	18.84	93	5664	8.35	5.49	4.17	X	X	X	X	X*
	19.17	91	5576	8.08	5.31	4.04	X	X	X	X	X*
	21.14	83	5576	7.32	4.81	3.66	X	X	X	X	X*
	22.59	77	5753	7.07	4.65	3.54	X	X	X	X	X*
	24.64	71	5797	6.53	4.29	3.27	X	X	X		
	25.34	69	5576	6.11	4.01	3.05	X	X	X	X	X*
	27.65	63	5576	5.60	3.68	2.80	X	X	X		
	28.38	62	5355	5.24	3.44	2.62	X			X	X*
	31.85	55	5576	4.86	3.19	2.43	X			X*	X*
	35.04	50	5841	4.63	3.04	2.31	X	X	X	X*	
	39.32	45	5576	3.94	2.59	1.97	X	X	X	X*	
	43.44	40	5576	3.56	2.34	1.78	X	X	X		
	46.92	37	4558	2.70	1.77	1.35	X	X	X		
	52.64	33	5116	2.70	1.77	1.35	X	X	X		
	59.68	29	3859	1.80	1.18	0.90	X	X	X*		
	66.96	26	4328	1.79	1.18	0.90	X	X	X*		
Based upon 1750 rpm Input Speed				1750 rpm	1150 rpm	875 rpm	-	1 hp	2 hp	5 hp	10 hp
				Input Speed				C-face Adapter Maximum Input Power ^			

◆ The maximum input power limit shown is the largest motor power typically combined with the gear unit. *The italicized power values shown are not the mechanical limit and often may be increased through discussion with our sales or engineering department.*

^ The NEMA C-face power limit must also be considered when selecting a reducer. The C-face Adapter's Maximum Input Power values are displayed under the Available Combinations and based on a 1750 rpm motor.

\* Caution - The motor power may exceed the gear unit's mechanical torque capacity

	W	56C	140TC	180TC	210TC
SK 92772.1	80	78	78	80	84
SK 93772.1	80	78	78	80	84

# 2 Stage Helical-bevel Dimensions

## Dimensions

- SK 92072.1
- SK 92172.1
- SK 92372.1
- SK 92672.1
- SK 92772.1
- SK 93072.1
- SK 93172.1
- SK 93372.1
- SK 93672.1
- SK 93772.1
- Input Dimensions
- Mounting Dimensions
- Optional Shafts

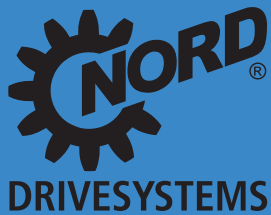
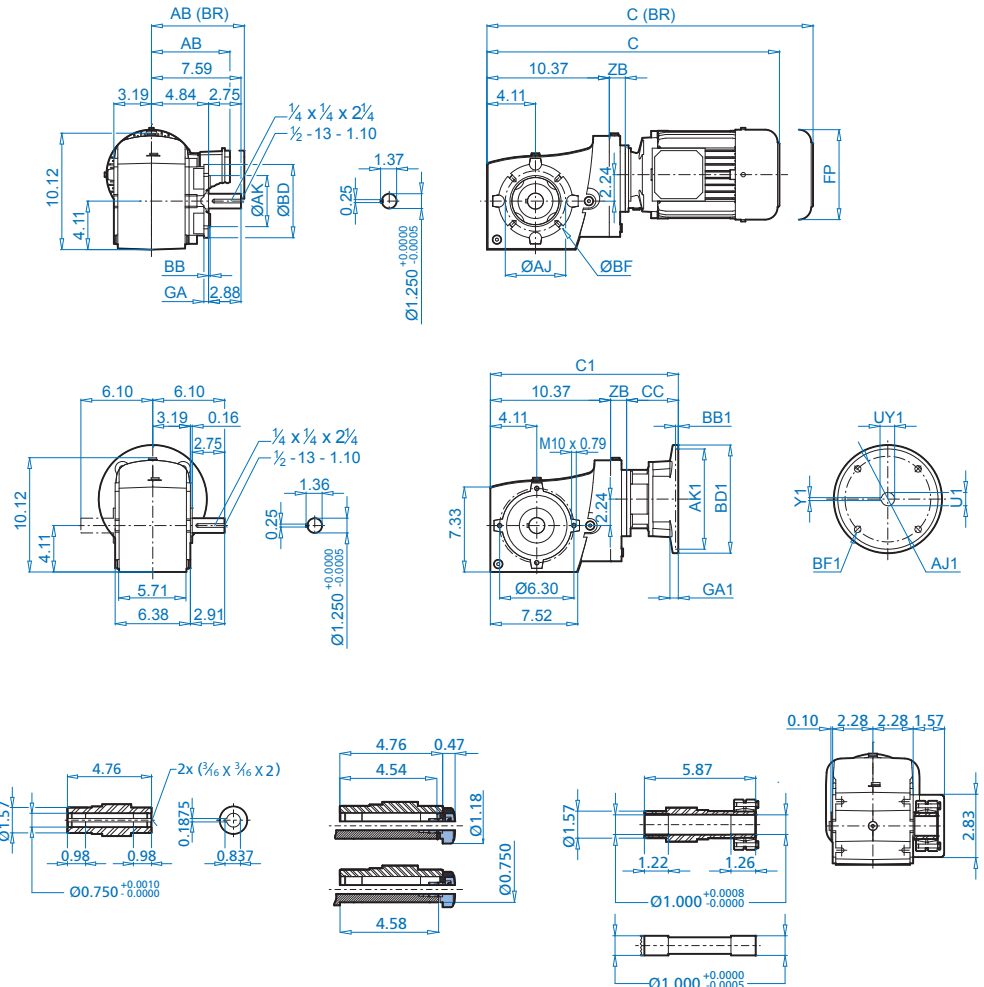

[www.nord.com](http://www.nord.com)

**UNICASE™**

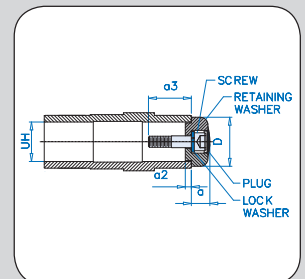
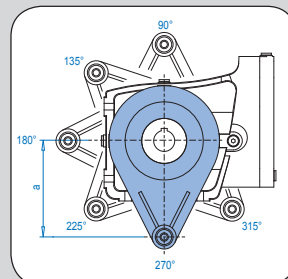
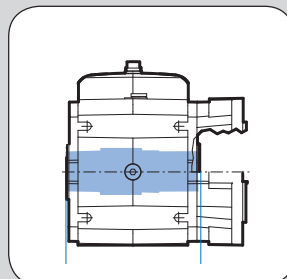

# SK 92072.1 + Motor

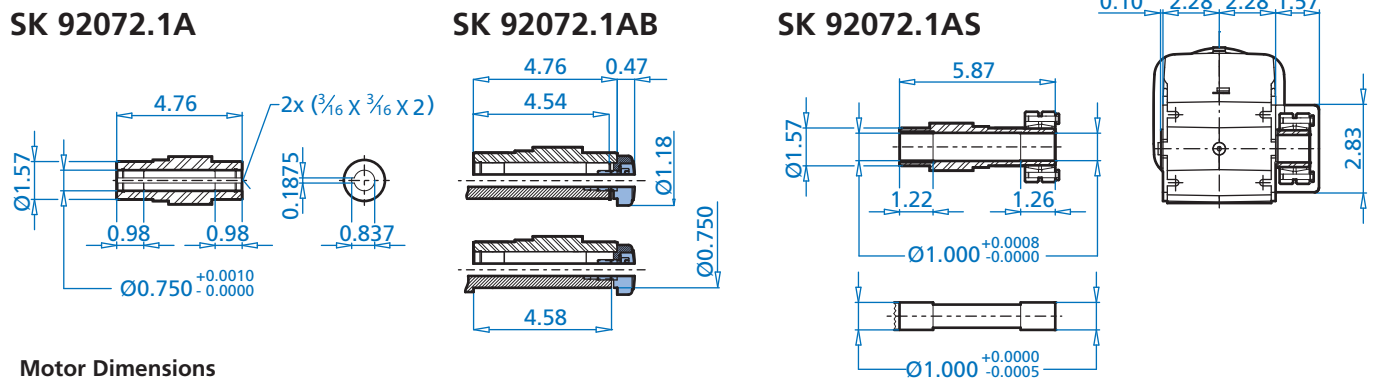
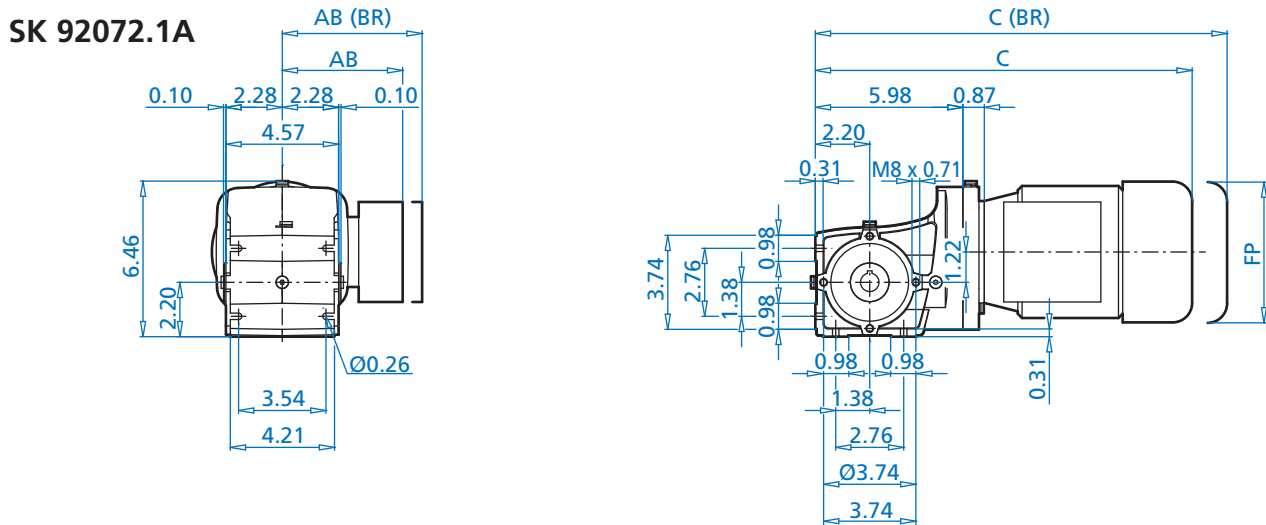
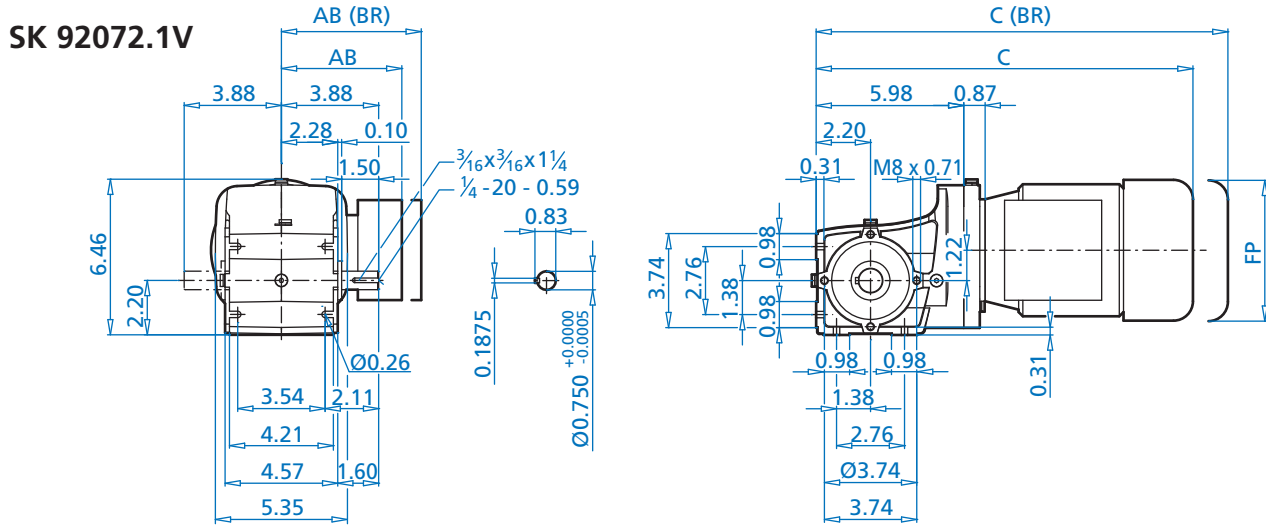
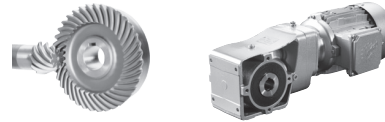

DIMENSIONS  
Dimensions in inches

ALTERNATE SHAFTS SEE PAGES 140 - 144

**Motor Dimensions**

	63S/L	71S/L	80S/L	90S	For Other Connection Possibilities please see → 130 & 131
Standard efficiency					
Energy efficiency					
Premium efficiency					
AB	4,51	4,86	5,59	5,79	
AB (BR)	4,84	5,24	5,59	5,79	
C	14,43	15,29	16,16	17,69	
C (BR)	16,63	17,57	18,68	20,65	
FP	5,09	5,72	6,43	7,19	

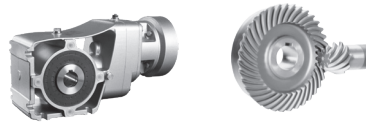

## SK 92072.1V

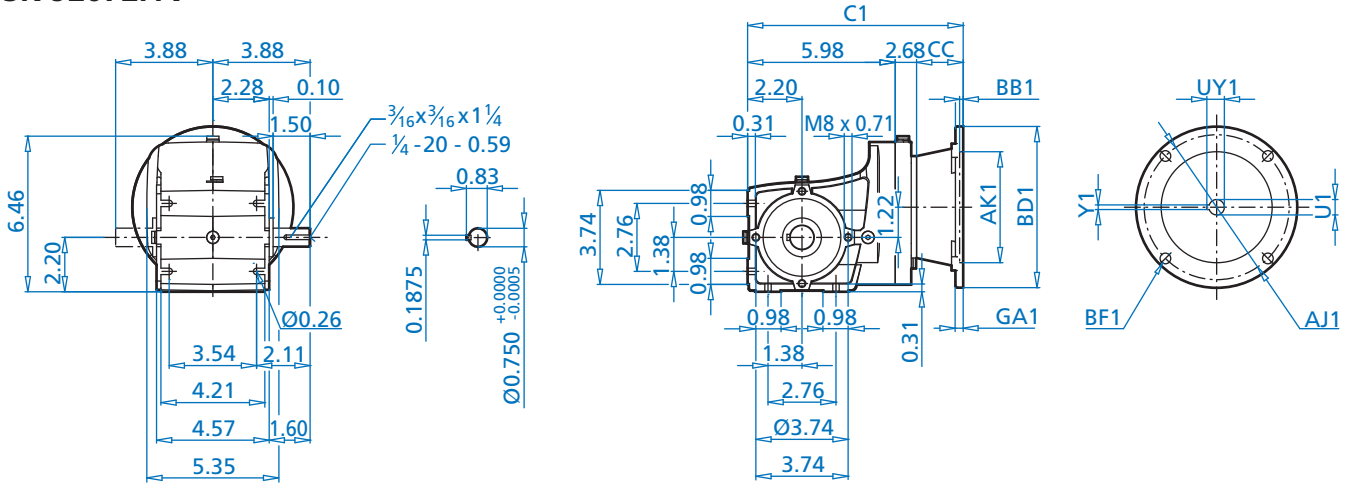

## SK 92072.1A

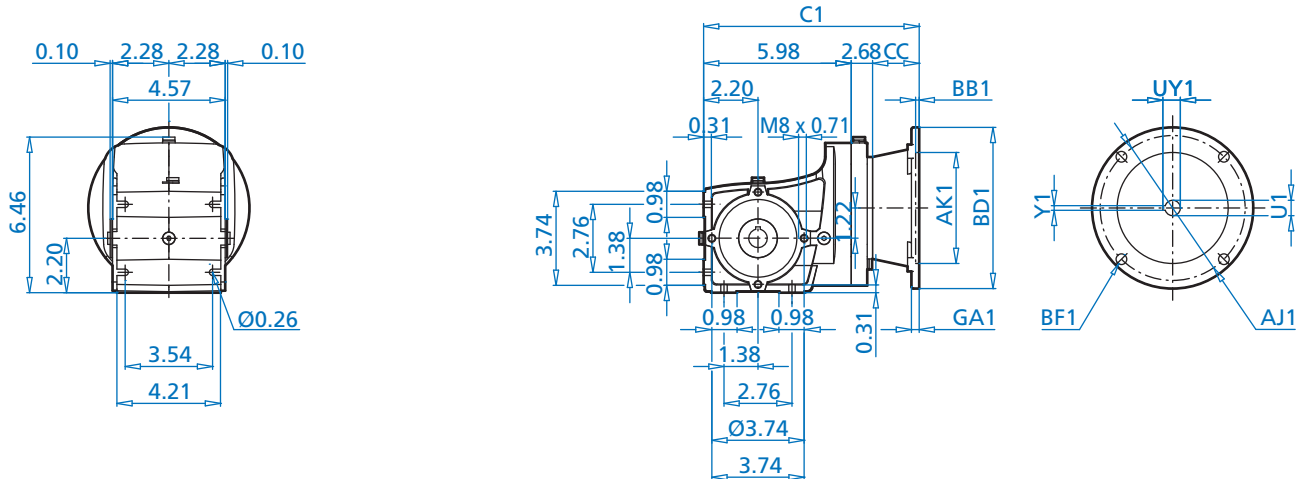

## SK 92072.1A

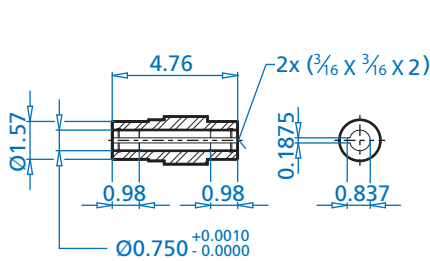

## SK 92072.1AB

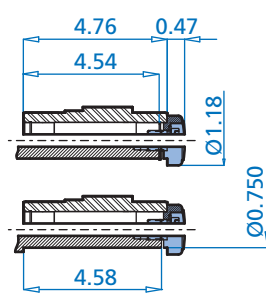

## SK 92072.1AS

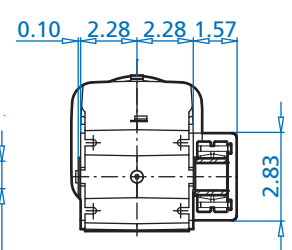
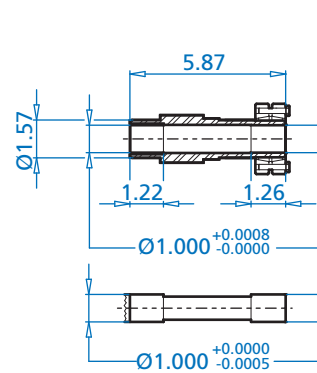

ALTERNATE SHAFTS SEE PAGES 140 - 144

### NEMA Dimensions

Type	AJ1	AK1	BB1	BD1	BF1	GA1	U1	UY1	Y1	C1	CC
56C	5,875	4,500	0,18	6,54	0,43	0,47	0,625	0,709	0,188	10,12	1,46
140TC	5,875	4,500	0,18	6,54	0,43	0,47	0,875	0,964	0,188	10,59	1,93

# SK 92072.1 + Motor

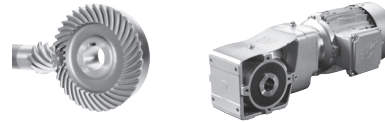

## SK 92072.1VF

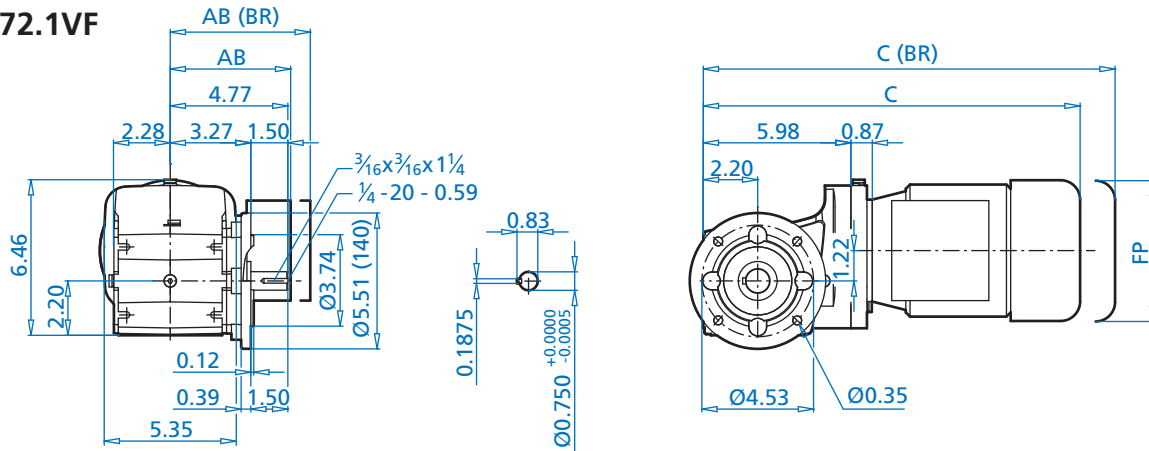

## SK 92072.1AF

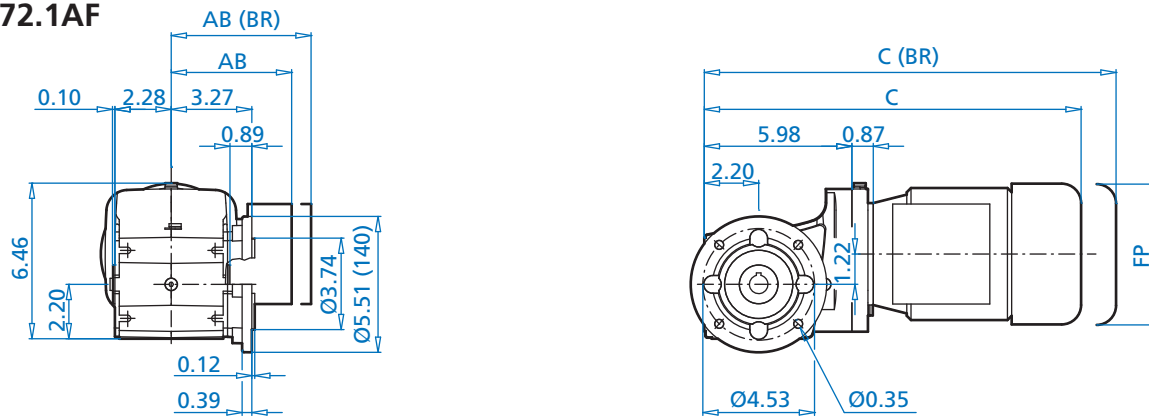

## SK 92072.1AF

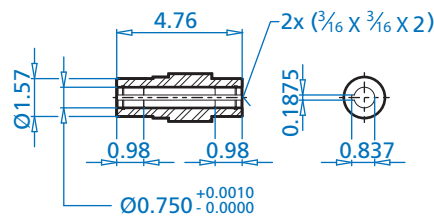

## SK 92072.1AB

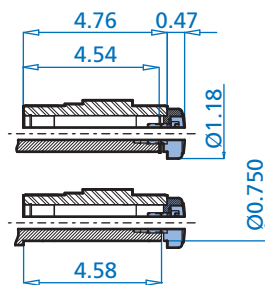

## SK 92072.1AFS

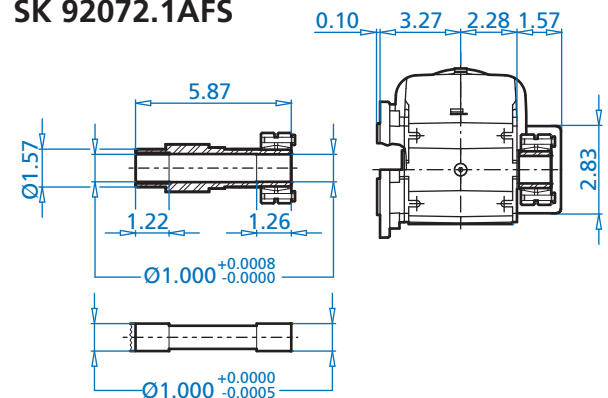

ALTERNATE SHAFTS SEE PAGES 140 - 144

### Motor Dimensions

	63S/L	71S/L	80S/L	90S	For Other Connection Possibilities please see → 130 & 131
Standard efficiency					
Energy efficiency			80LH	90SH	
Premium efficiency			80LP	90SP	
AB	4,51	4,86	5,59	5,79	
AB (BR)	4,84	5,24	5,59	5,79	
C	14,43	15,29	16,16	17,69	
C (BR)	16,63	17,57	18,68	20,65	
FP	5,09	5,72	6,43	7,19	

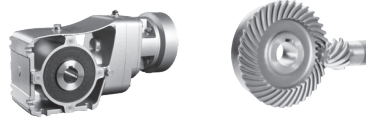

**SK 92072.1VF**

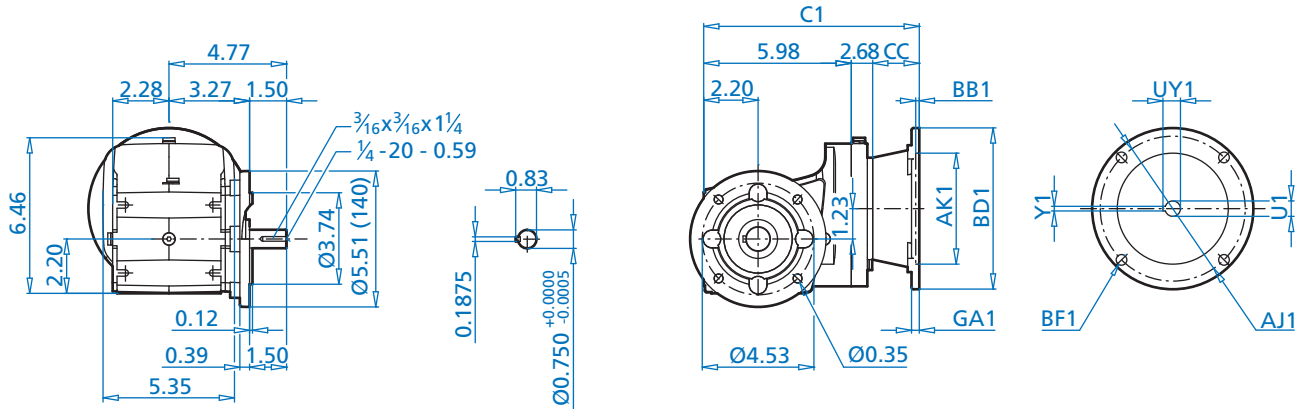

**SK 92072.1AF**

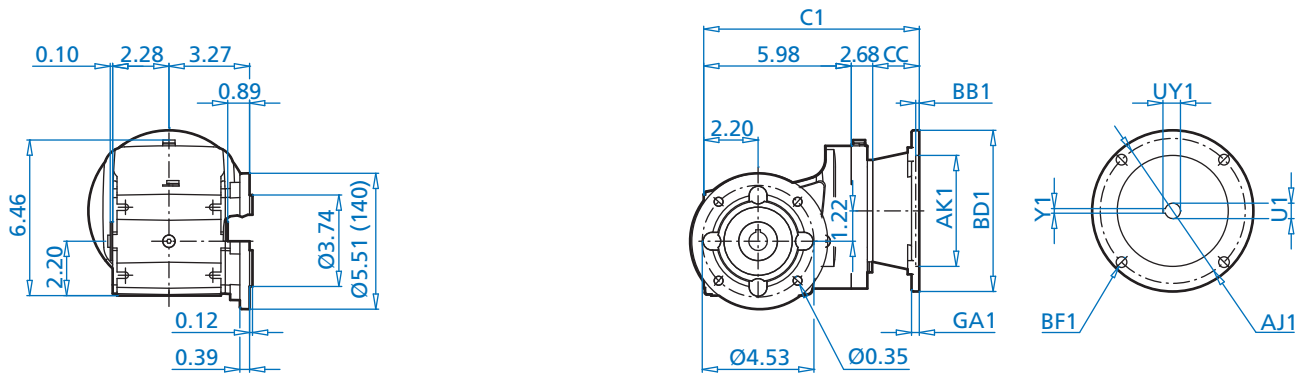

**SK 92072.1AF**

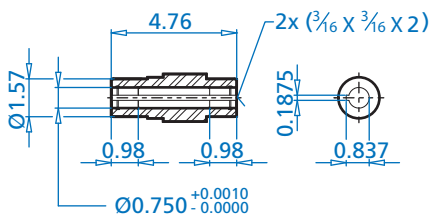

**SK 92072.1AB**

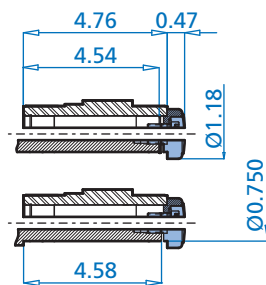

**SK 92072.1AFS**

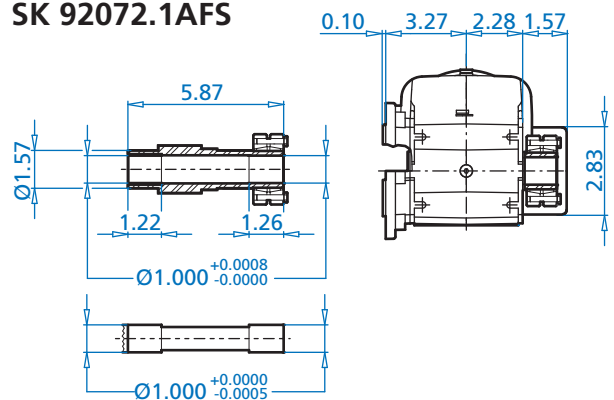

ALTERNATE SHAFTS SEE PAGES 140 - 144

**NEMA Dimensions**

Type	AJ1	AK1	BB1	BD1	BF1	GA1	U1	UY1	Y1	C1	CC
56C	5,875	4,500	0,18	6,54	0,43	0,47	0,625	0,709	0,188	10,12	1,46
140TC	5,875	4,500	0,18	6,54	0,43	0,47	0,875	0,964	0,188	10,59	1,93



# SK 92172.1 + Motor

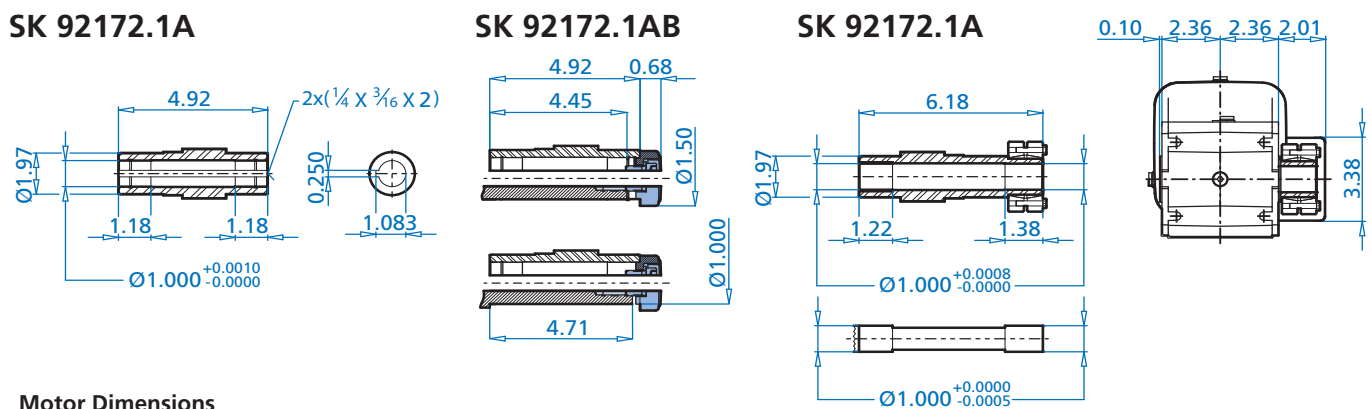
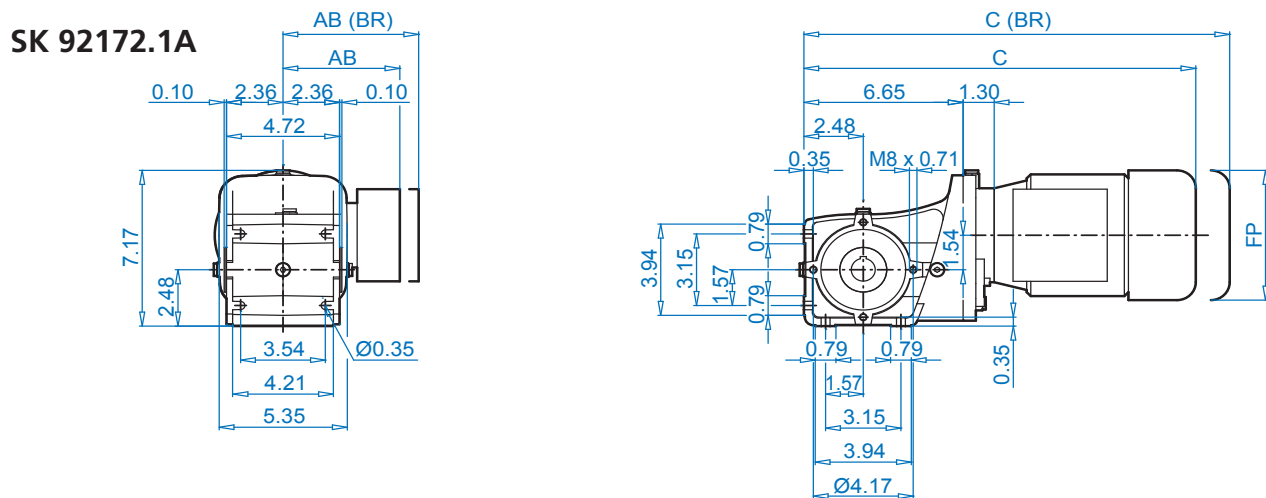
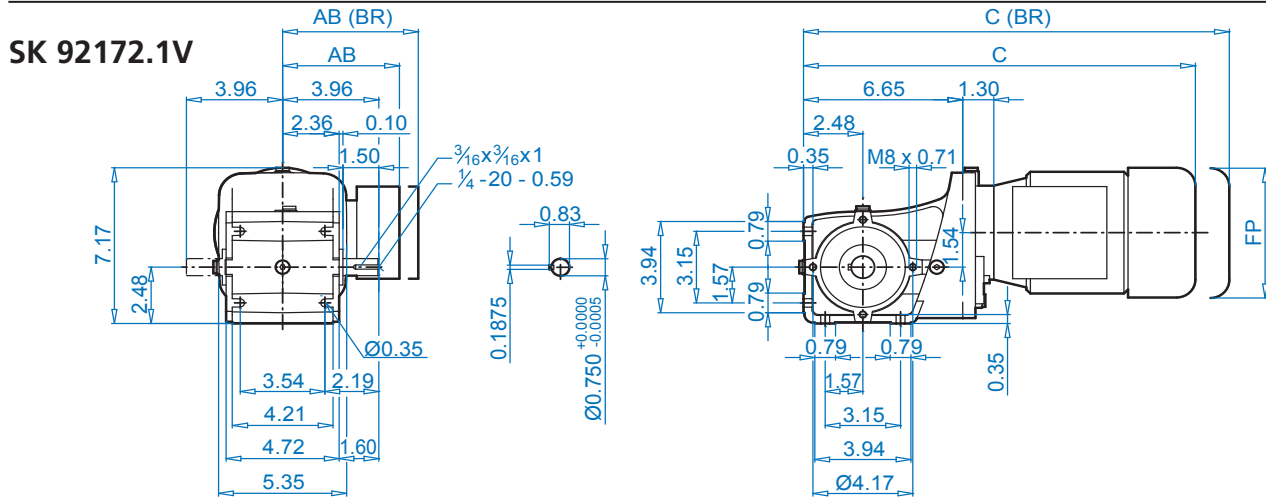

ALTERNATE SHAFTS SEE PAGES 140 - 144

## Motor Dimensions

Standard efficiency	63S/L	71S/L	80S/L	90S/L	For Other Connection Possibilities please see → 130 & 131
Energy efficiency			80LH	90SH/LH	
Premium efficiency			80LP	90SP/LP	
AB	4,51	4,86	5,59	5,79	
AB (BR)	4,84	5,24	5,59	5,79	
C	15,54	16,39	17,26	18,80	
C (BR)	17,74	18,68	19,78	21,75	
FP	5,09	5,72	6,43	7,19	



**SK 92172.1V**

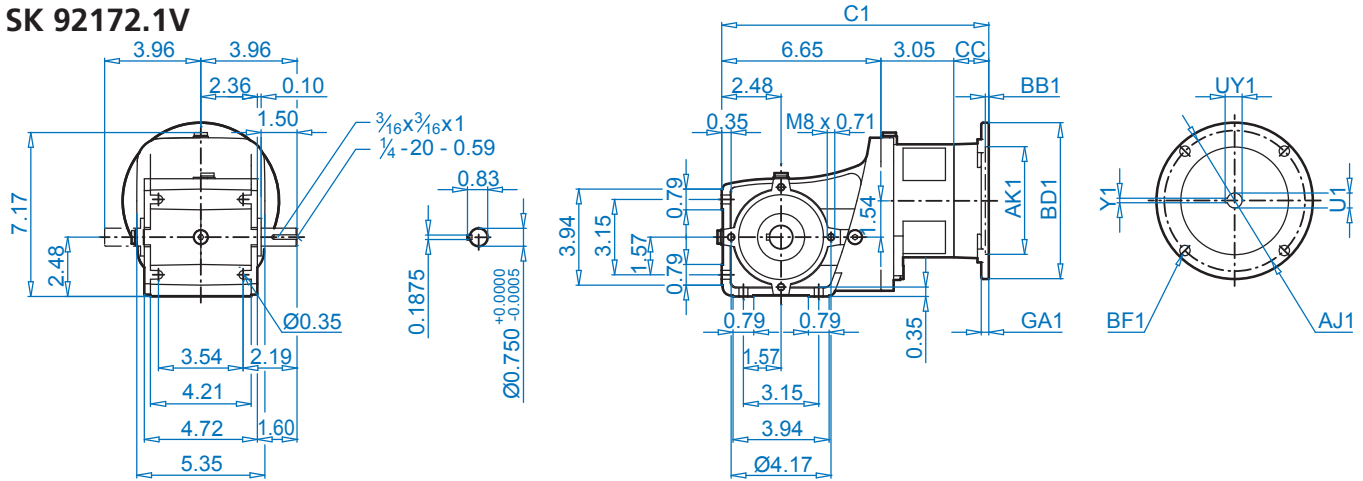

**SK 92172.1A**

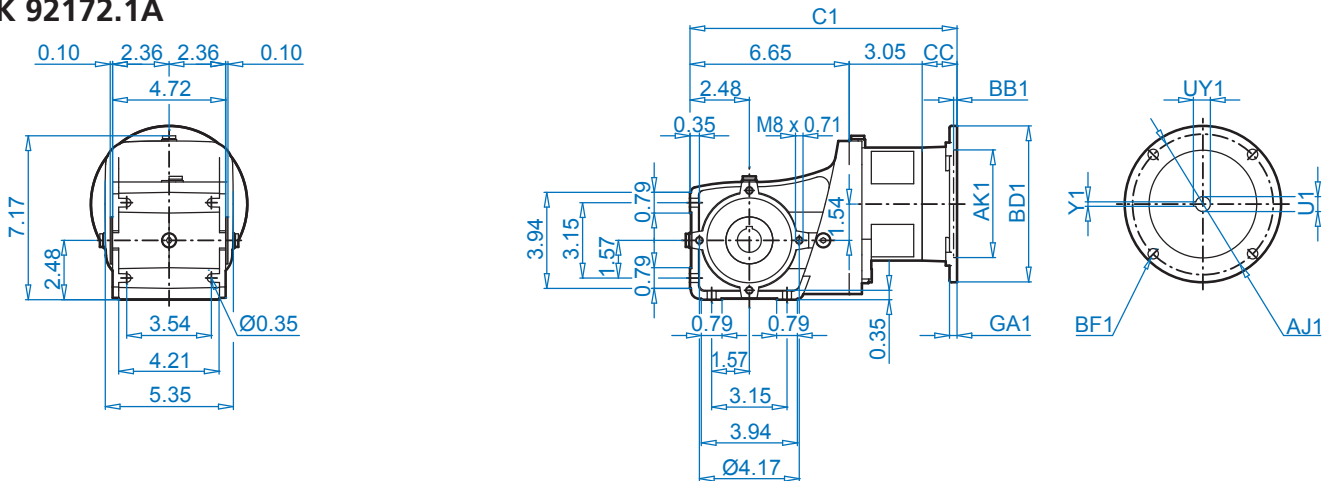

**SK 92172.1A**

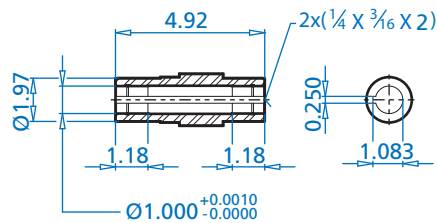

**SK 92172.1AB**

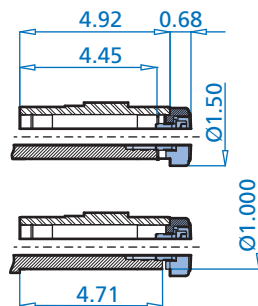

**SK 92172.1AS**

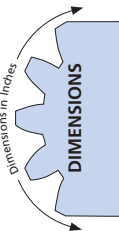
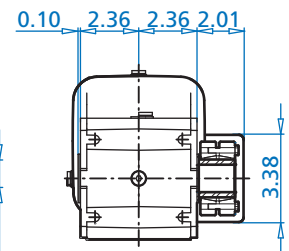
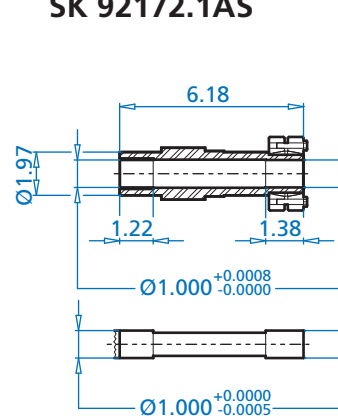

ALTERNATE SHAFTS SEE PAGES 140 - 144

**NEMA Dimensions**

Type	AJ1	AK1	BB1	BD1	BF1	GA1	U1	UY1	Y1	C1	CC
56C	5,875	4,500	0,18	6,54	0,43	0,47	0,625	0,709	0,188	11,16	1,46
140TC	5,875	4,500	0,18	6,54	0,43	0,47	0,875	0,964	0,188	11,63	1,93

# SK 92172.1 + Motor

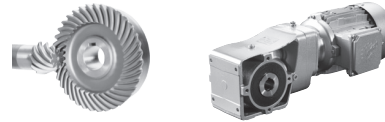

## SK 92172.1VF

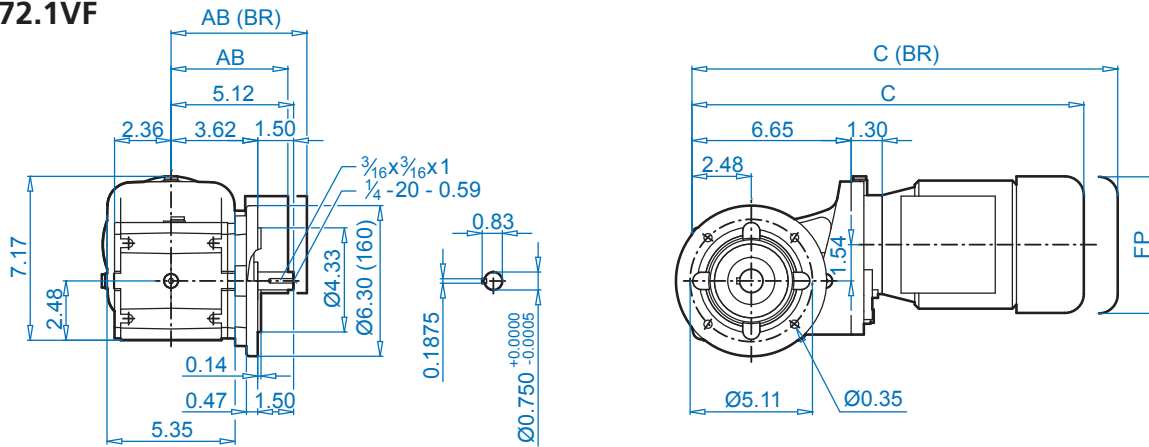

## SK 92172.1AF

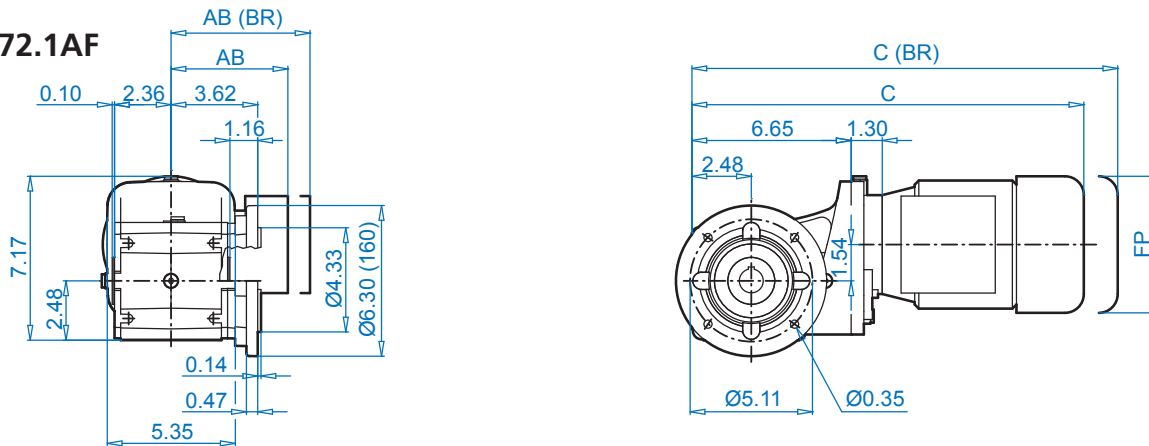

## SK 92172.1AF

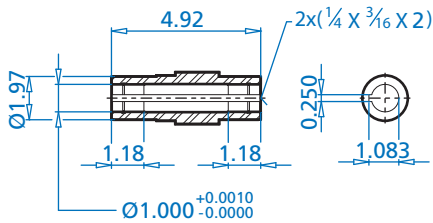

## SK 92172.1AB

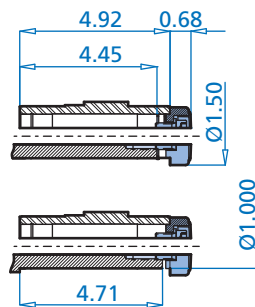

## SK 92172.1AFS

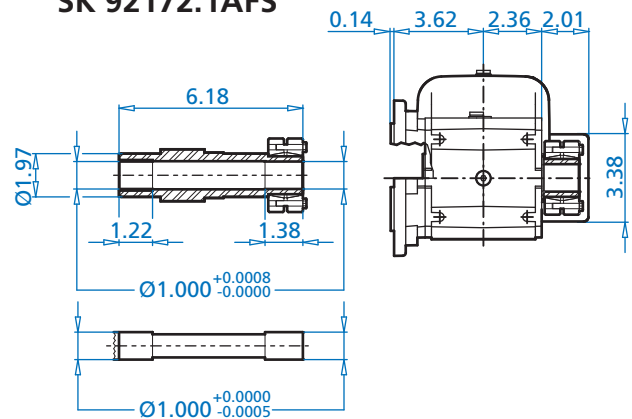

DIMENSIONS  
Dimensions in inches

ALTERNATE SHAFTS SEE PAGES 140 - 144

### Motor Dimensions

	63S/L	71S/L	80S/L	90S/L	For Other Connection Possibilities please see → 130 & 131
Standard efficiency	63S/L	71S/L	80S/L	90S/L	
Energy efficiency			80LH	90SH/LH	
Premium efficiency			80LP	90SP/LP	
AB	4,51	4,86	5,59	5,79	
AB (BR)	4,84	5,24	5,59	5,79	
C	15,54	16,39	17,26	18,80	
C (BR)	17,74	18,68	19,78	21,75	
FP	5,09	5,72	6,43	7,19	

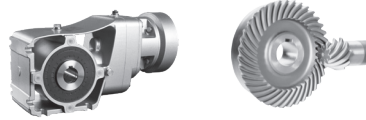

**SK 92172.1VF**

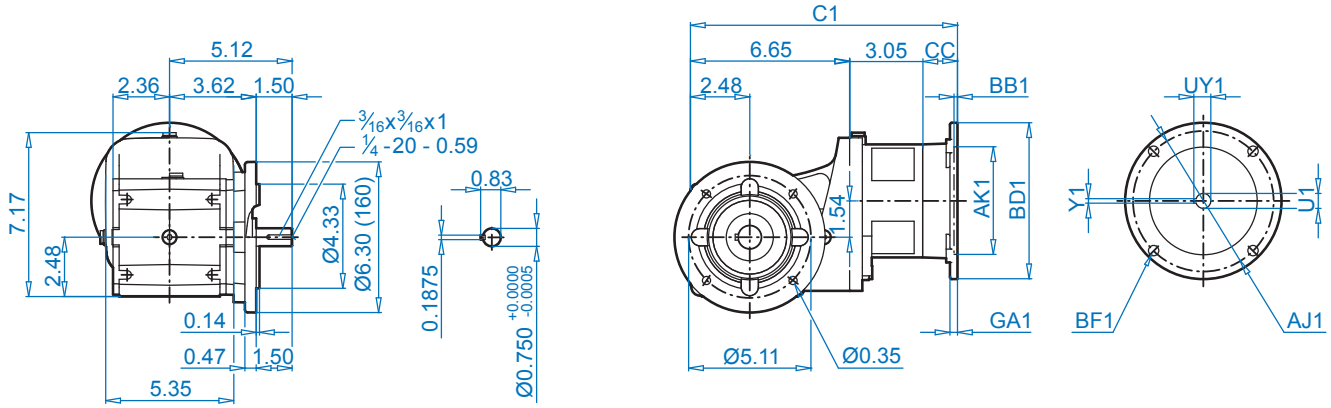

**SK 92172.1AF**

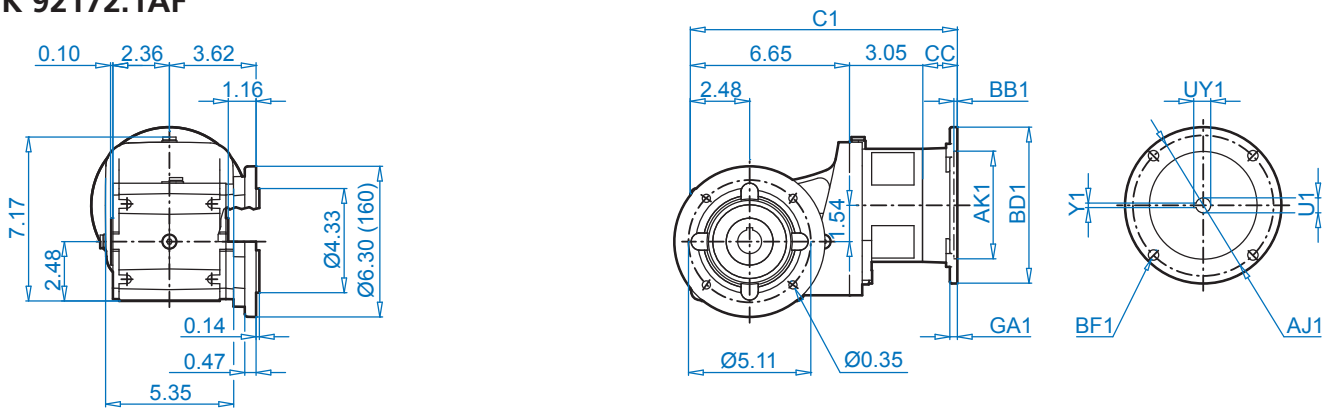

**SK 92172.1AF**

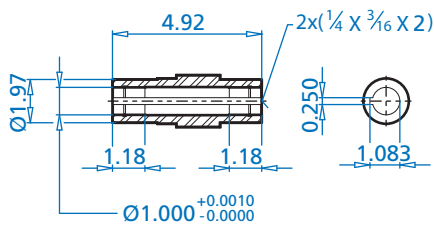

**SK 92172.1AB**

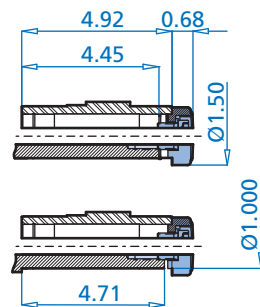

**SK 92172.1AFS**

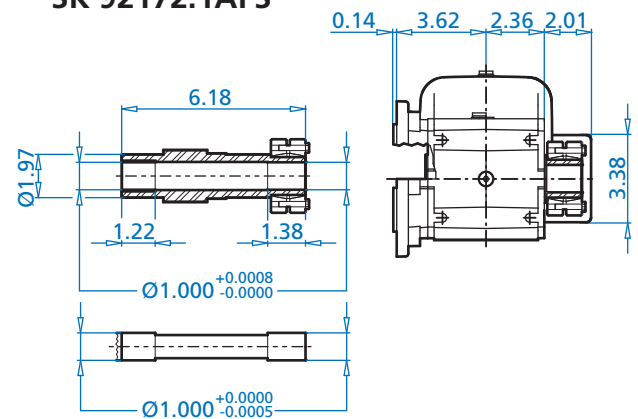

Dimensions in Inches  
DIMENSIONS

ALTERNATE SHAFTS SEE PAGES 140 - 144

**NEMA Dimensions**

Type	AJ1	AK1	BB1	BD1	BF1	GA1	U1	UY1	Y1	C1	CC
56C	5,875	4,500	0,18	6,54	0,43	0,47	0,625	0,709	0,188	11,16	1,46
140TC	5,875	4,500	0,18	6,54	0,43	0,47	0,875	0,964	0,188	11,63	1,93

# SK 92372.1+ Motor

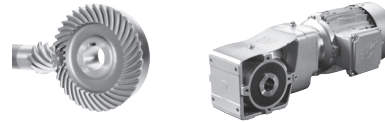

## SK 92372.1V

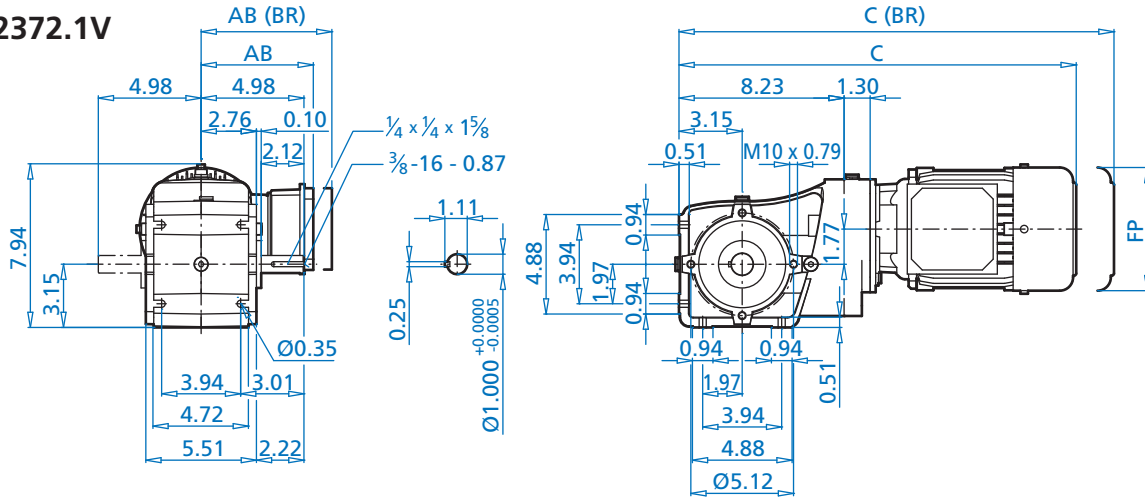

## SK 92372.1A

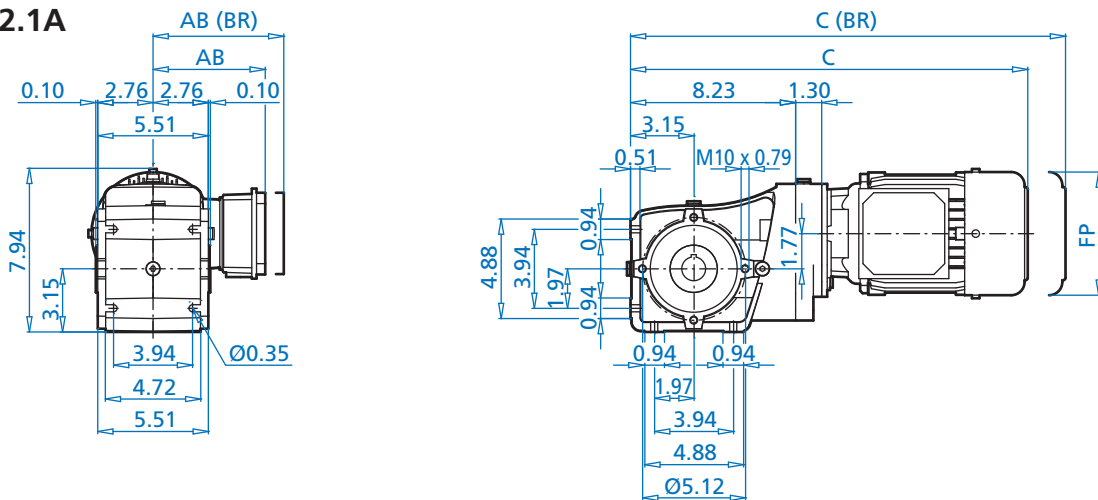

DIMENSIONS  
Dimensions in inches

## SK 92372.1A

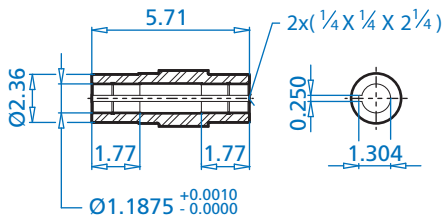

## SK 92372.1AB

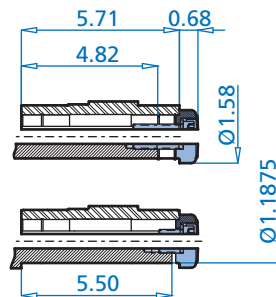

## SK 92372.1AS

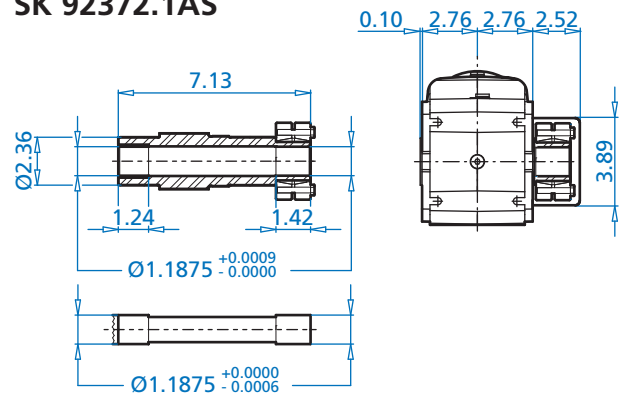

ALTERNATE SHAFTS SEE PAGES 140 - 144

### Motor Dimensions

	63S/L	71S/L	80S/L	90S/L	100L/LA	112M	112MH	For Other Connection Possibilities please see → 130 & 131
Standard efficiency								
Energy efficiency			80LH	90SH/LH	100LH			
Premium efficiency			80LP	90SP/LP	100LP		112MP	
AB	4,51	4,86	5,59	5,79	6,65	7,05	7,05	
AB (BR)	4,84	5,24	5,59	5,79	6,77	7,17	7,17	
C	17,26	18,83	19,82	21,39	22,61	23,48	24,48	
C (BR)	19,46	21,12	22,34	24,35	26,22	27,19	28,18	
FP	5,09	5,72	6,43	7,19	7,90	8,87	8,87	

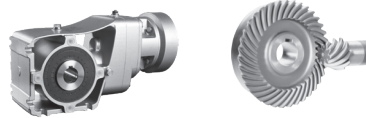

## SK 92372.1V

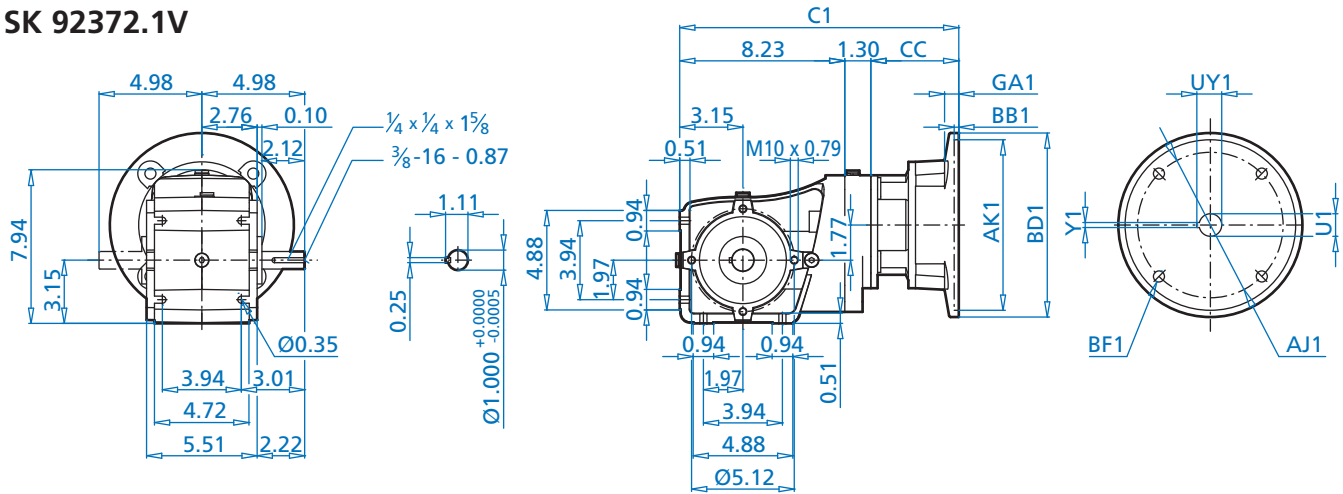

## SK 92372.1A

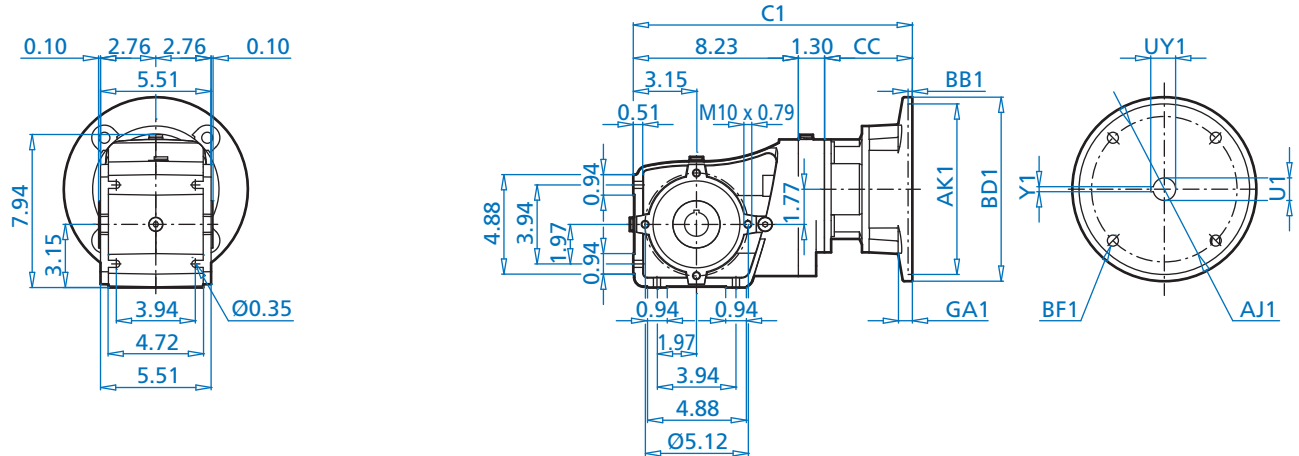

## SK 92372.1A

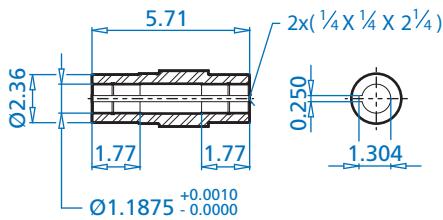

## SK 92372.1AB

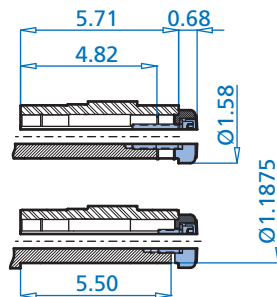

## SK 92372.1AS

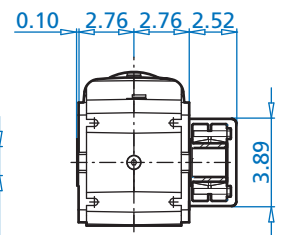
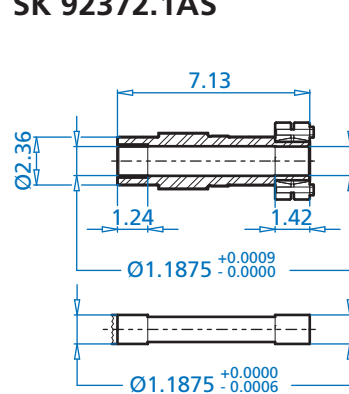

ALTERNATE SHAFTS SEE PAGES 140 - 144

### NEMA Dimensions

Type	AJ1	AK1	BB1	BD1	BF1	GA1	U1	UY1	Y1	C1	CC
56C	5,875	4,500	0,18	6,54	0,43	0,47	0,625	0,709	0,188	13,21	3,68
140TC	5,875	4,500	0,18	6,54	0,43	0,47	0,875	0,964	0,188	13,68	4,15
180TC	7,250	8,500	0,23	9,17	0,55	0,71	1,125	1,241	0,250	13,91	4,38



# SK 92372.1 + Motor



## SK 92372.1VF

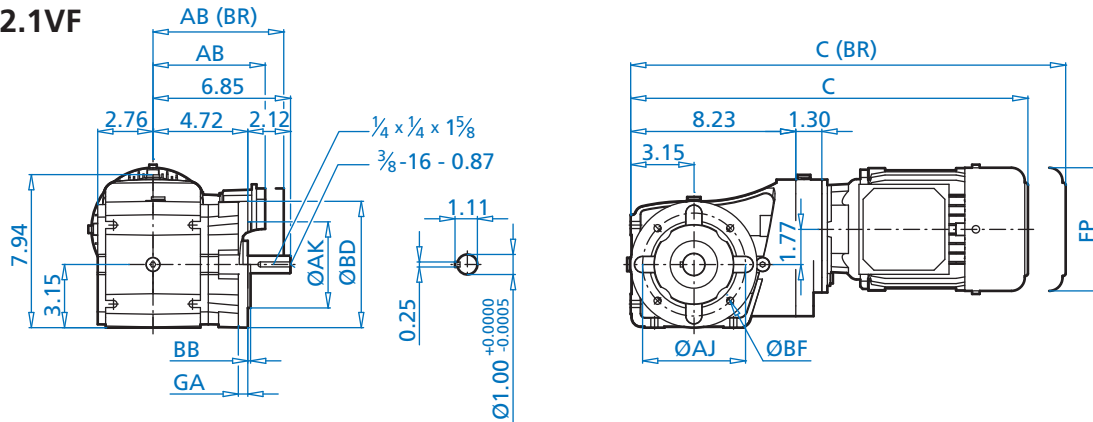

## SK 92372.1AF

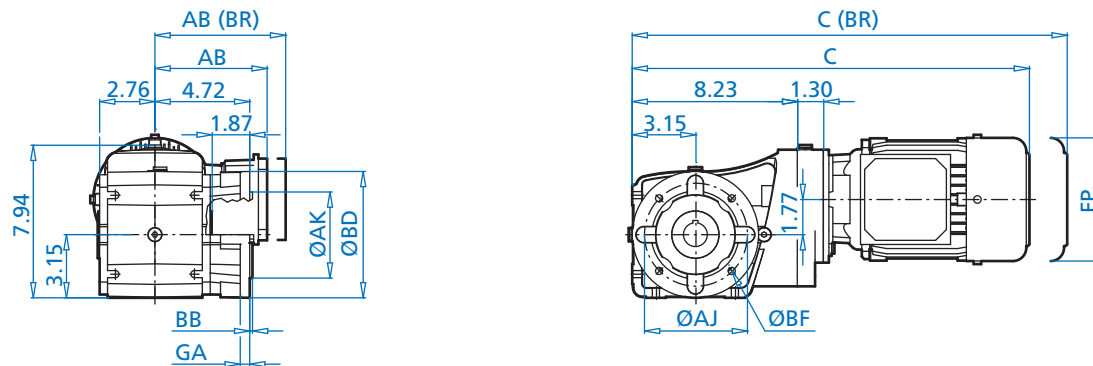

## SK 92372.1AF

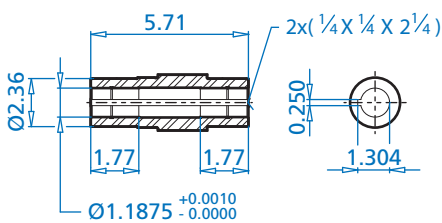

## SK 92372.1AB

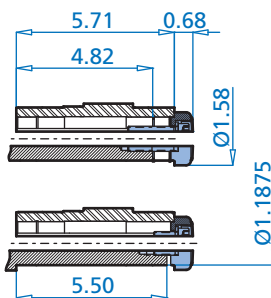

## SK 92372.1AFS

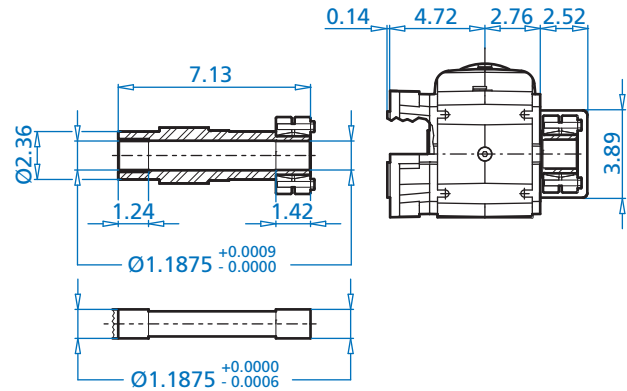

### Mounting flange

BD (mm)	AJ	AK	BB	BF	GA
6.30 (160)	5.12	4.331 +0.0005 -0.0004	0.14	0.35	0.47
7.87 (200)	6.50	5.118 +0.0005 -0.0004	0.14	0.43	0.47

### Motor Dimensions

	63S/L	71S/L	80S/L	90S/L	100L/LA	112M	112MH	For Other Connection Possibilities please see ⇨ 130 & 131
Standard efficiency								
Energy efficiency			80LH	90SH/LH	100LH			
Premium efficiency			80LP	90SP/LP	100LP		112MP	
AB	4,51	4,86	5,59	5,79	6,65	7,05	7,05	
AB (BR)	4,84	5,24	5,59	5,79	6,77	7,17	7,17	
C	17,26	18,83	19,82	21,39	22,61	23,48	24,48	
C (BR)	19,46	21,12	22,34	24,35	26,22	27,19	28,18	
FP	5,09	5,72	6,43	7,19	7,90	8,87	8,87	

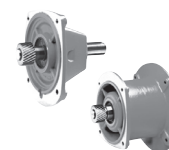

ALTERNATE SHAFTS SEE PAGES 140 - 144



# SK 92672.1 + Motor

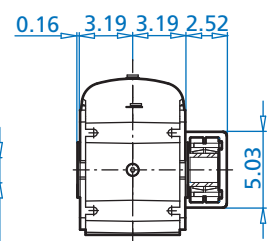
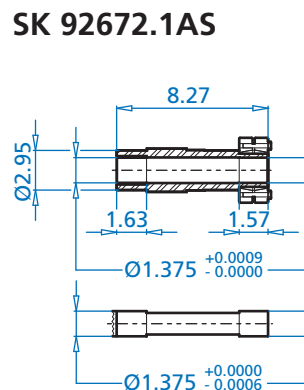
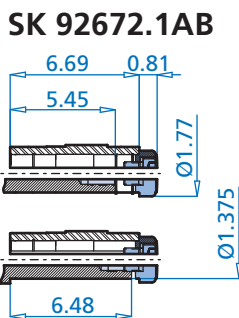
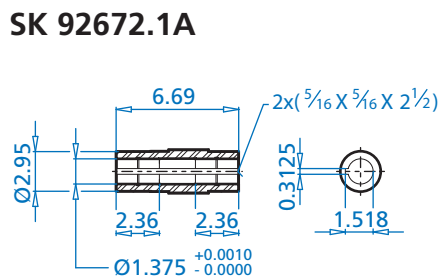
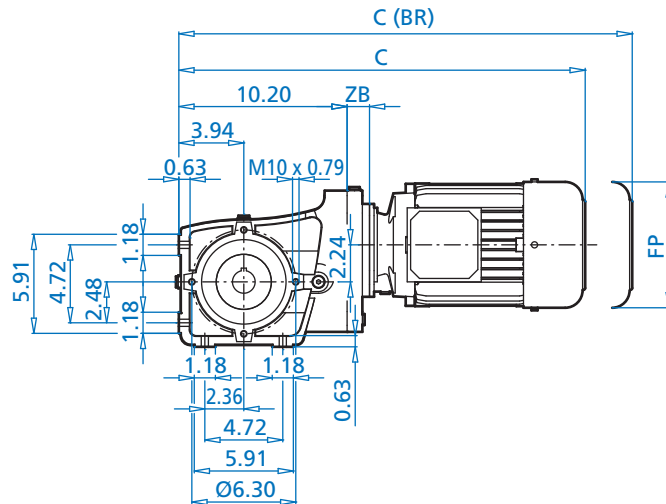
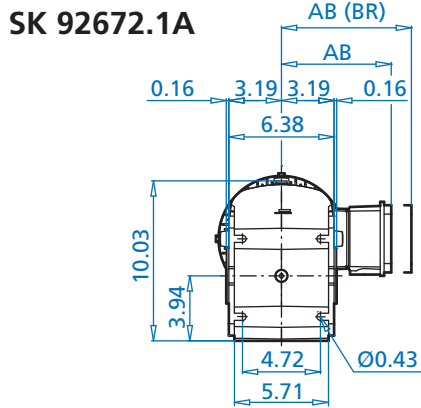
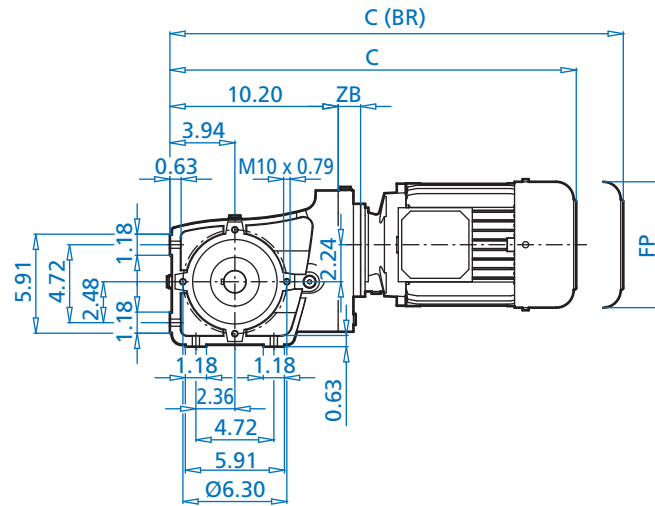
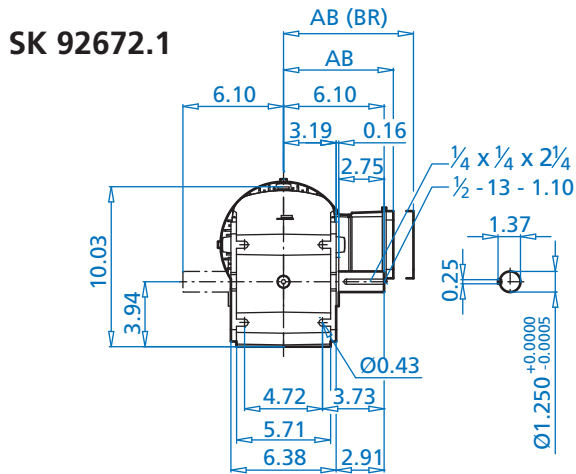
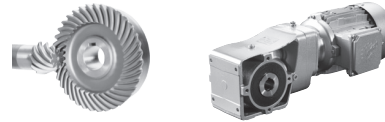

ALTERNATE SHAFTS SEE PAGES 140 - 144

## Motor Dimensions

	71S/L	80S/L	90S/L	100L/LA	112M	132S/M	For Other Connection Possibilities please see ⇨ 130 & 131	
Standard efficiency	71S/L	80S/L	90S/L	100L/LA	112M	132S/M		
Energy efficiency		80LH	90SH/LH	100LH		112MH		132SH/MH
Premium efficiency		80LP	90SP/LP	100LP		112MP		132SP/MP
AB	4,86	5,59	5,79	6,65	7,05	7,05	8,03	
AB (BR)	5,24	5,59	5,79	6,77	7,17	7,17	7,91	
C	20,87	21,86	23,43	24,65	25,52	26,52	28,94	
C (BR)	23,16	24,38	26,39	28,26	29,22	30,22	33,16	
FP	5,72	6,43	7,19	7,90	8,87	8,87	10,45	
ZB	1,37	1,37	1,37	1,37	1,37	1,37	1,61	

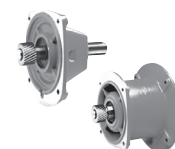



**SK 92672.1**

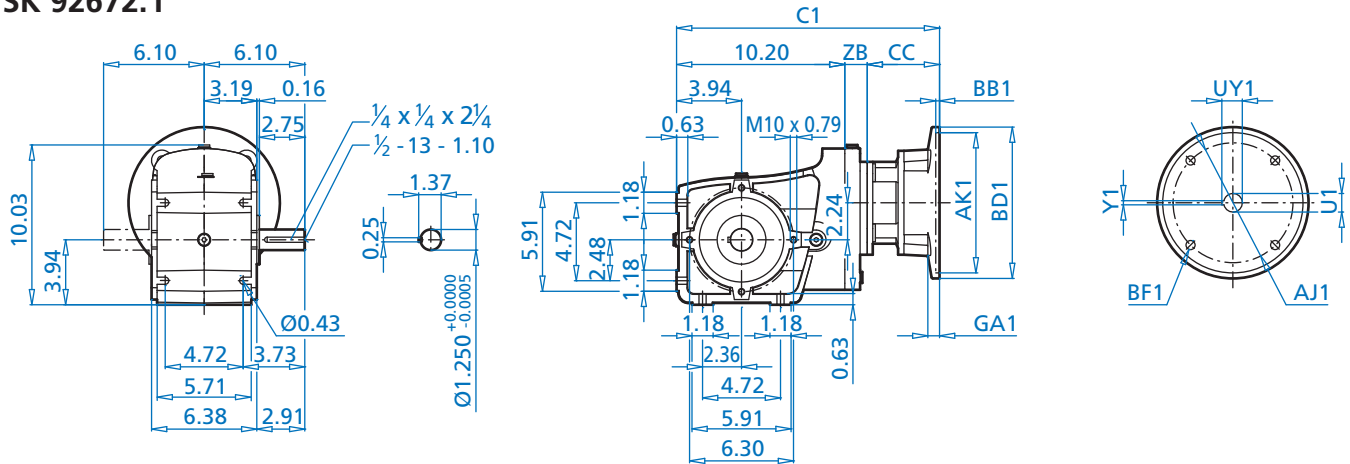

**SK 92672.1A**

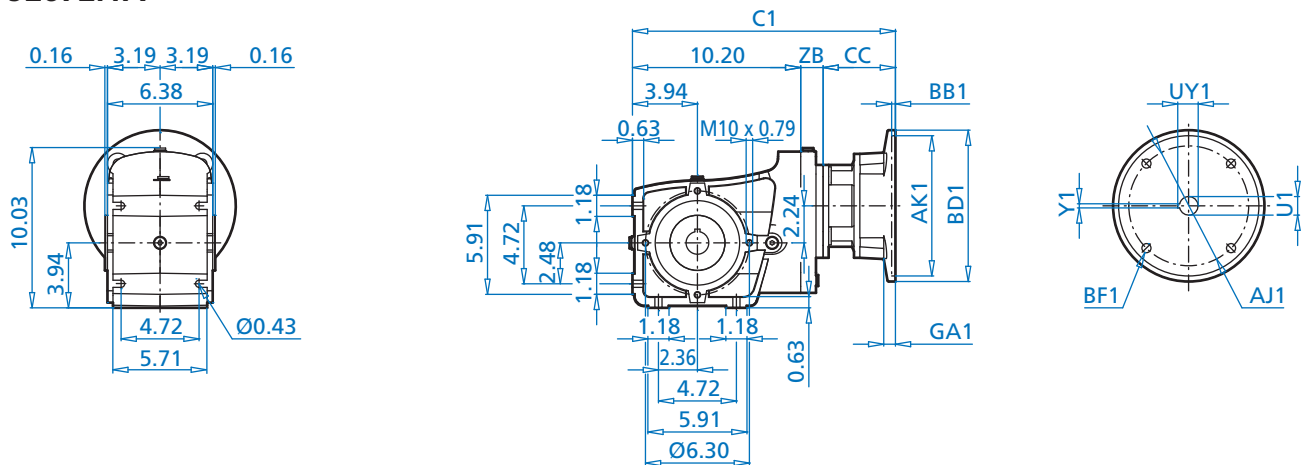

**SK 92672.1A**

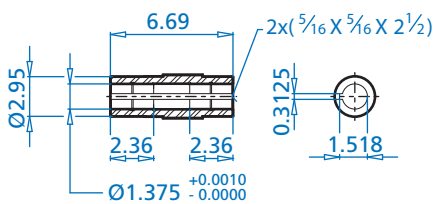

**SK 92672.1AB**

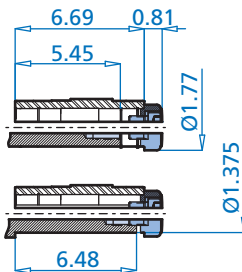

**SK 92672.1AS**

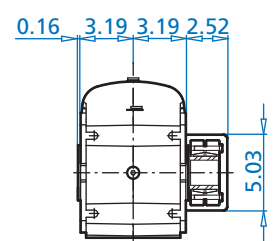
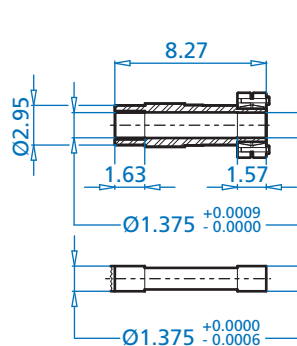

ALTERNATE SHAFTS SEE PAGES 140 - 144

**NEMA Dimensions**

Type	AJ1	AK1	BB1	BD1	BF1	GA1	U1	UY1	Y1	C1	CC	ZB
56C	5,875	4,500	0,18	6,54	0,43	0,47	0,625	0,709	0,188	15,25	3,68	1,37
140TC	5,875	4,500	0,18	6,54	0,43	0,47	0,875	0,964	0,188	15,72	4,15	1,37
180TC	7,250	8,500	0,23	9,17	0,55	0,71	1,125	1,241	0,250	15,95	4,38	1,37
210TC	7,250	8,500	0,23	9,17	0,59	0,98	1,375	1,518	0,312	16,76	4,96	1,61

# SK 92672.1 + Motor

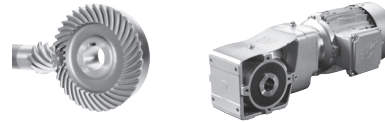

## SK 92672.1VF

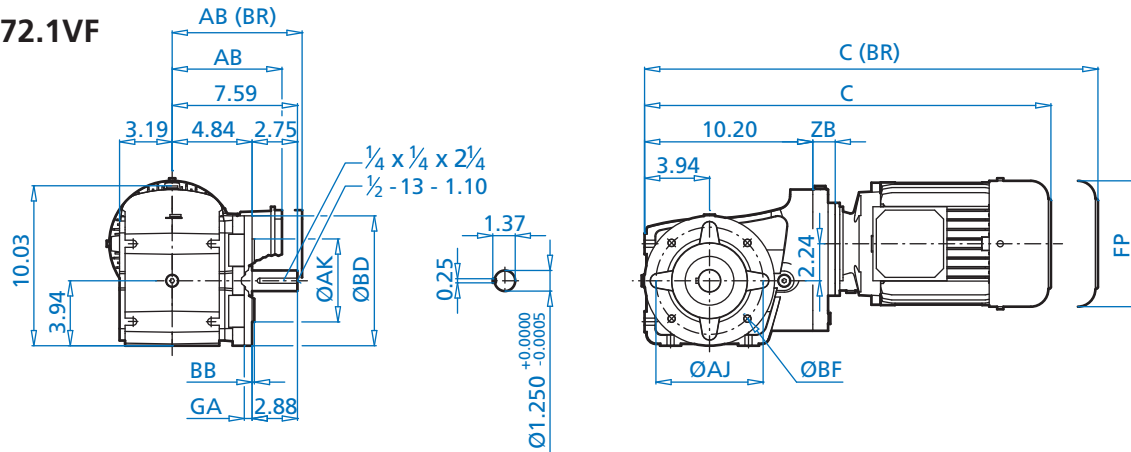

## SK 92672.1AF

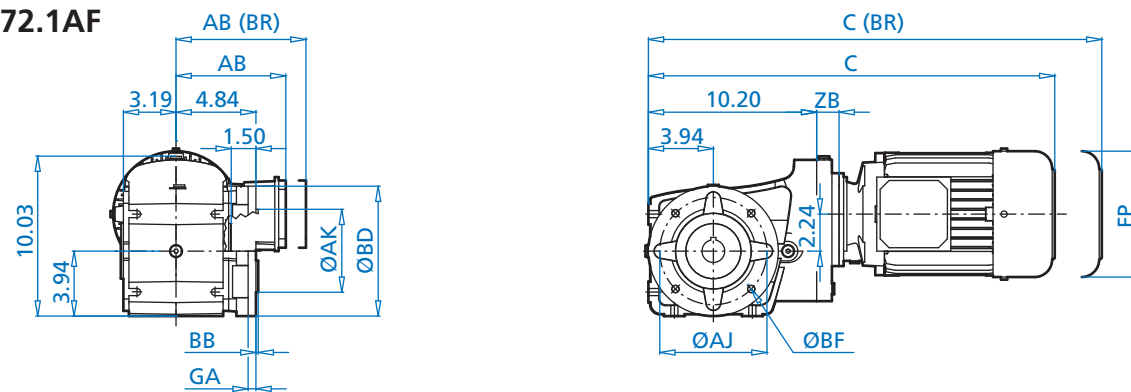

## SK 92672.1AF

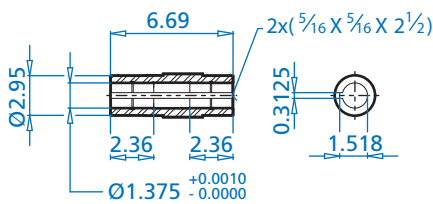

## SK 92672.1AB

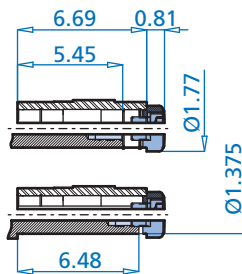

## SK 92672.1AFS

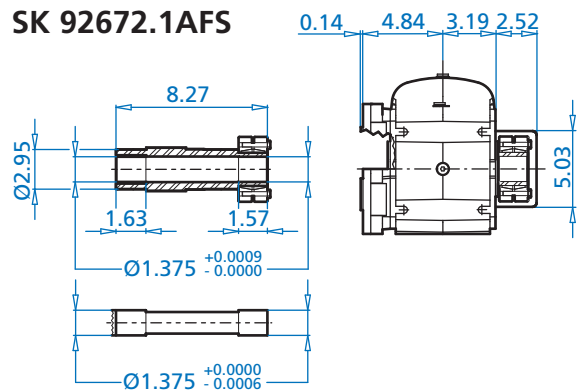

### Mounting flange

BD (mm)	AJ	AK	BB	BF	GA
6.30 (160)	5.12	4.331 +0.0005 -0.0004	0.14	0.39	0.47
7.87 (200)	6.50	5.118 +0.0006 -0.0004	0.14	0.43	0.47

### Motor Dimensions

	71S/L	80S/L	90S/L	100L/LA	112M	132S/M	For Other Connection Possibilities please see ⇨ 130 & 131
Standard efficiency	71S/L	80S/L	90S/L	100L/LA	112M	132S/M	
Energy efficiency		80LH	90SH/LH	100LH		112MH 132SH/MH	
Premium efficiency		80LP	90SP/LP	100LP		112MP 132SP/MP	
AB	4,86	5,59	5,79	6,65	7,05	7,05	8,03
AB (BR)	5,24	5,59	5,79	6,77	7,17	7,17	7,91
C	20,87	21,86	23,43	24,65	25,52	26,52	28,94
C (BR)	23,16	24,38	26,39	28,26	29,22	30,22	33,16
FP	5,72	6,43	7,19	7,90	8,87	8,87	10,45
ZB	1,37	1,37	1,37	1,37	1,37	1,37	1,61

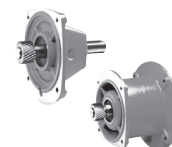

ALTERNATE SHAFTS SEE PAGES 140 - 144

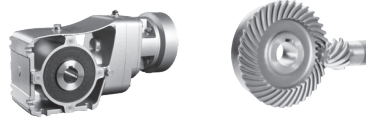

**SK 92672.1VF**

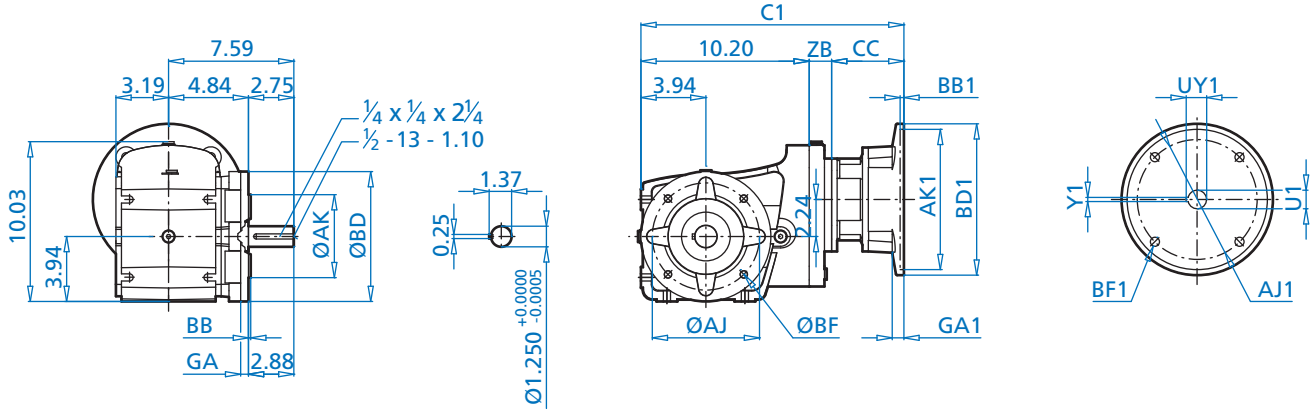

**SK 92672.1AF**

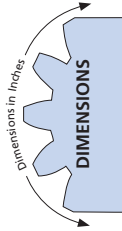
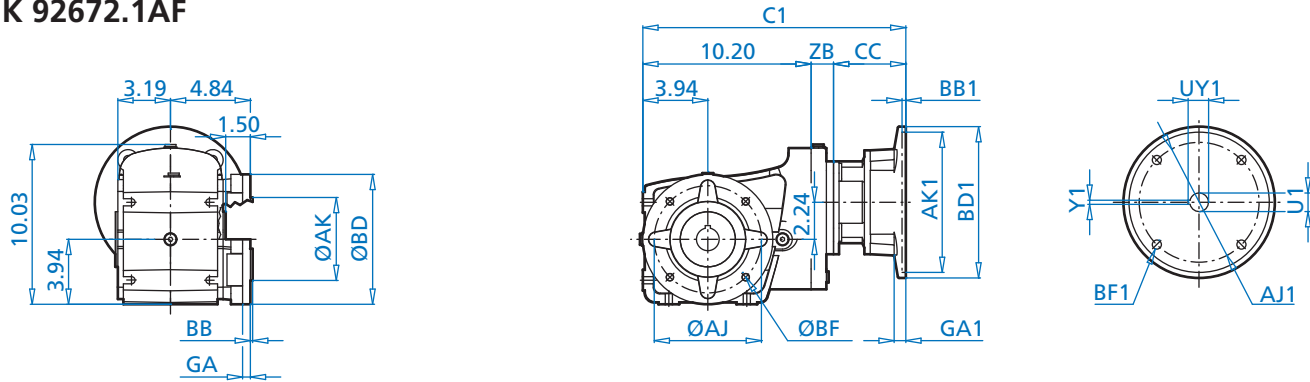

**SK 92672.1AF**

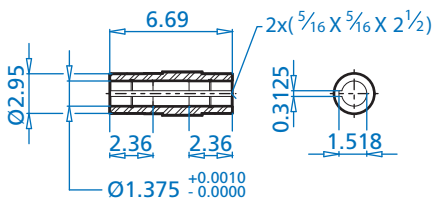

**SK 92672.1AB**

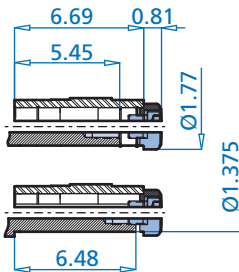

**SK 92672.1AFS**

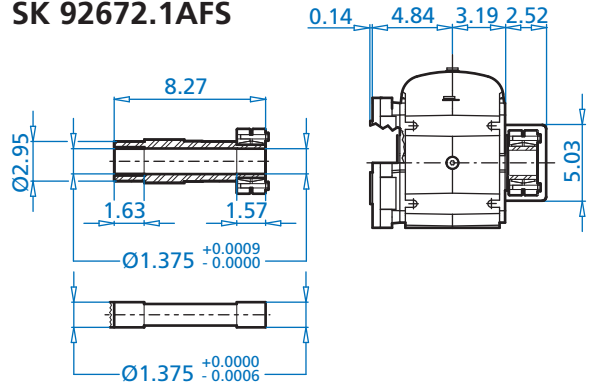

ALTERNATE SHAFTS SEE PAGES 140 - 144

**Mounting flange**

BD (mm)	AJ	AK	BB	BF	GA
6.30 (160)	5.12	4.331 <sup>+0.0005</sup> <sub>-0.0004</sub>	0.14	0.39	0.47
7.87 (200)	6.50	5.118 <sup>+0.0006</sup> <sub>-0.0004</sub>	0.14	0.43	0.47

**NEMA Dimensions**

Type	AJ1	AK1	BB1	BD1	BF1	GA1	U1	UY1	Y1	C1	CC	ZB
56C	5,875	4,500	0,18	6,54	0,43	0,47	0,625	0,709	0,188	15,25	3,68	1,37
140TC	5,875	4,500	0,18	6,54	0,43	0,47	0,875	0,964	0,188	15,72	4,15	1,37
180TC	7,250	8,500	0,23	9,17	0,55	0,71	1,125	1,241	0,250	15,95	4,38	1,37
210TC	7,250	8,500	0,23	9,17	0,59	0,98	1,375	1,518	0,312	16,76	4,96	1,61



# SK 92772.1 + Motor

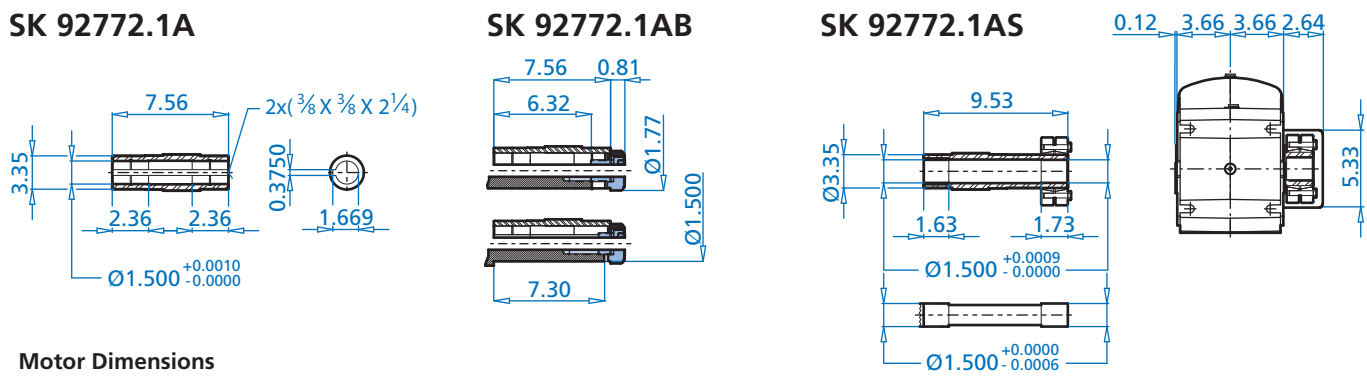
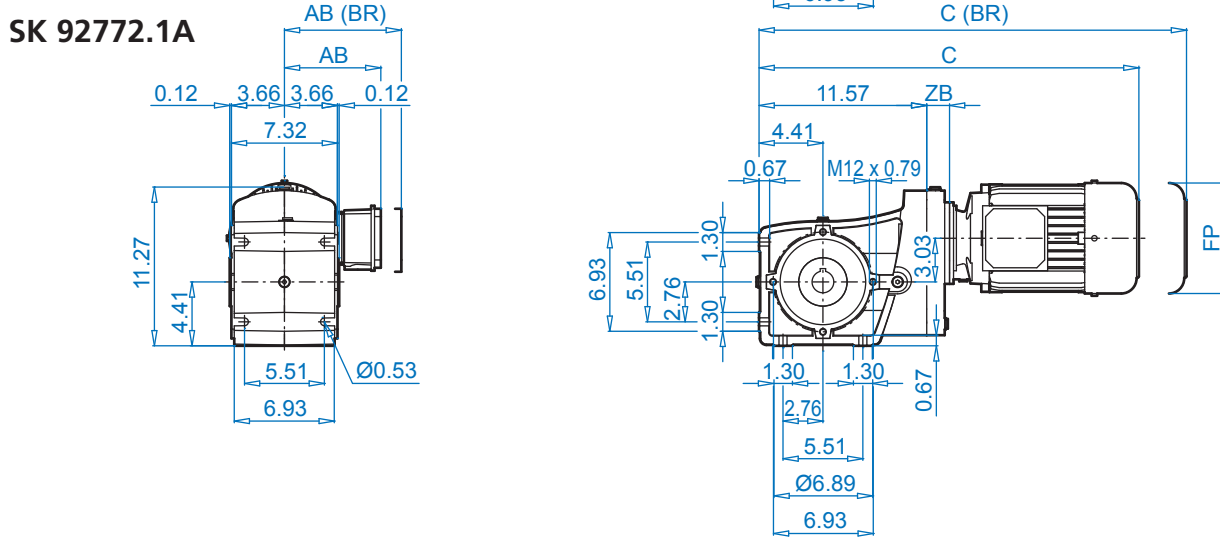
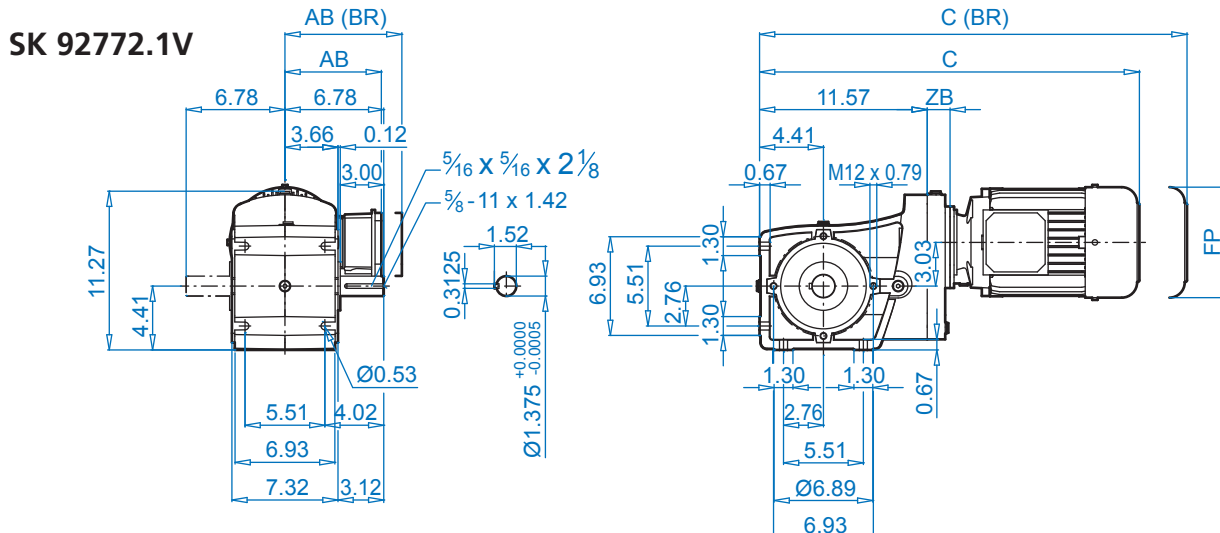

ALTERNATE SHAFTS SEE PAGES 140 - 144

**Motor Dimensions**

	71L	80S/L	90S/L	100L/LA	112M	132S/M	For Other Connection Possibilities please see ↗ 130 & 131
Standard efficiency	71L	80S/L	90S/L	100L/LA	112M	132S/M	
Energy efficiency		80LH	90SH/LH	100LH		112MH 132SH/MH	
Premium efficiency		80LP	90SP/LP	100LP		112MP 132SP/MP	
AB	4,86	5,59	5,79	6,65	7,05	7,05	8,03
AB (BR)	5,24	5,59	5,79	6,77	7,17	7,17	7,91
C	22,47	23,45	25,03	26,25	27,12	28,11	30,54
C (BR)	24,75	25,97	27,98	29,85	30,82	31,81	34,75
FP	5,72	6,43	7,19	7,90	8,87	8,87	10,45
ZB	1,59	1,59	1,59	1,59	1,59	1,59	1,82

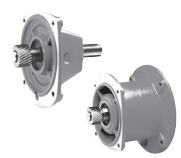



**SK 92772.1V**

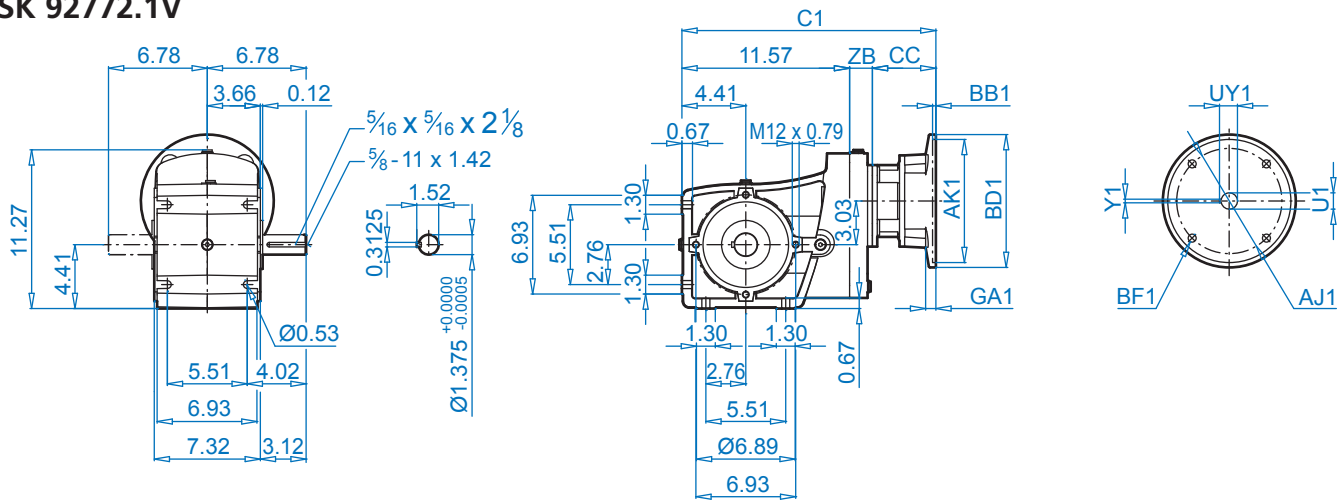

**SK 92772.1A**

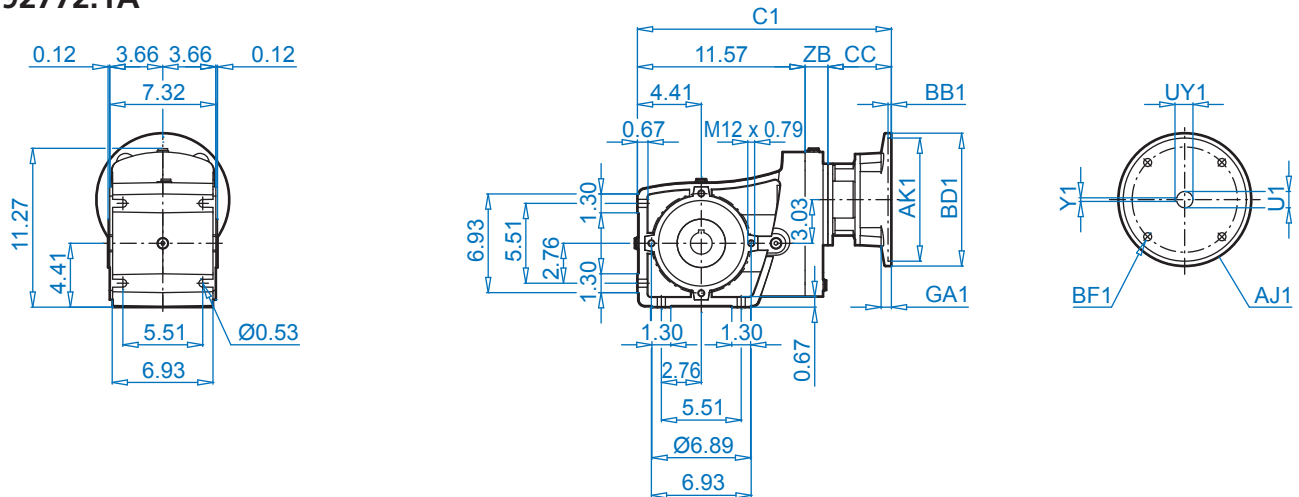

**SK 92772.1A**

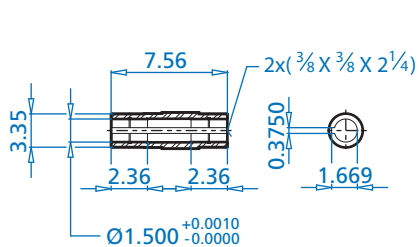

**SK 92772.1AB**

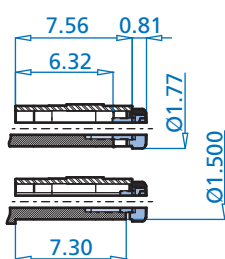

**SK 92772.1AS**

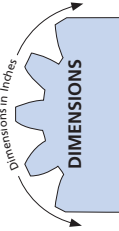
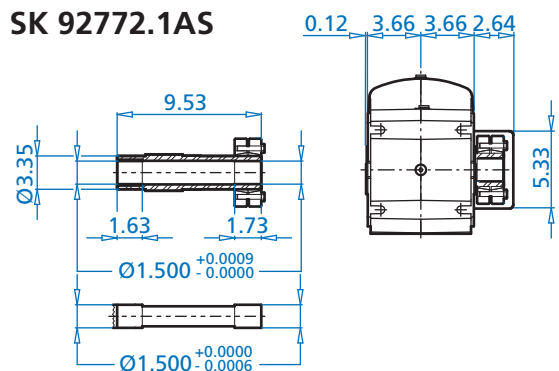

ALTERNATE SHAFTS SEE PAGES 140 - 144

**NEMA Dimensions**

Type	AJ1	AK1	BB1	BD1	BF1	GA1	U1	UY1	Y1	C1	CC	ZB
56C	5,875	4,500	0,18	6,54	0,43	0,47	0,625	0,709	0,188	16,84	3,68	1,59
140TC	5,875	4,500	0,18	6,54	0,43	0,47	0,875	0,964	0,188	17,31	4,15	1,59
180TC	7,250	8,500	0,23	9,17	0,55	0,71	1,125	1,241	0,250	17,54	4,38	1,59
210TC	7,250	8,500	0,23	9,17	0,59	0,98	1,375	1,518	0,312	18,36	4,96	1,82

# SK 92772.1 + Motor

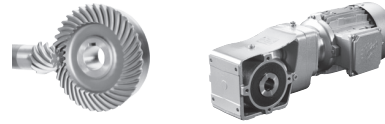

SK 92772.1VF

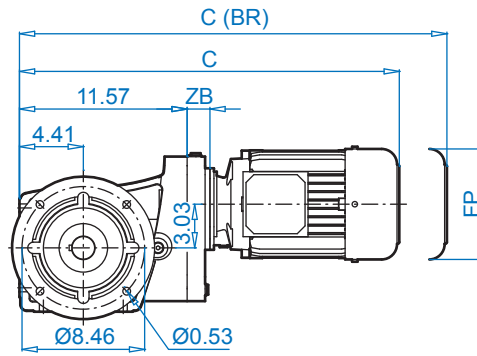
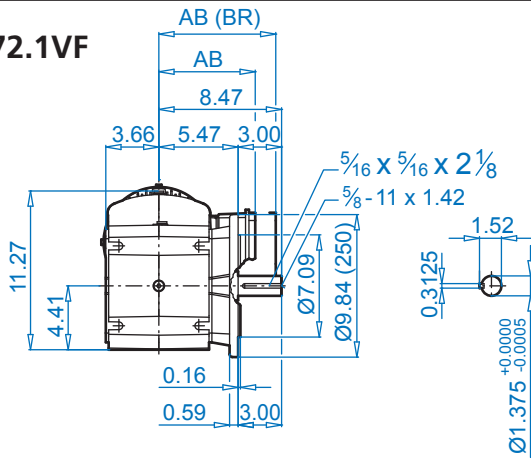

SK 92772.1AF

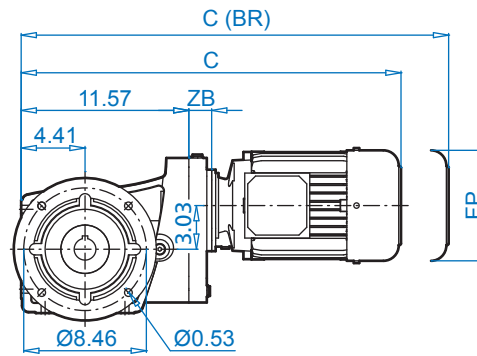
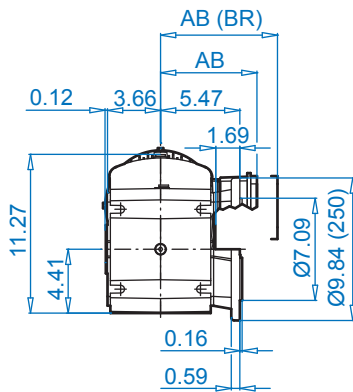

SK 92772.1AF

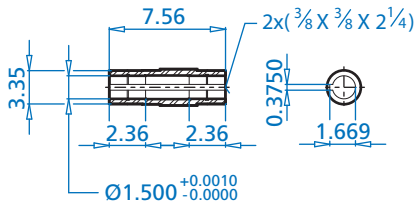

SK 92772.1AB

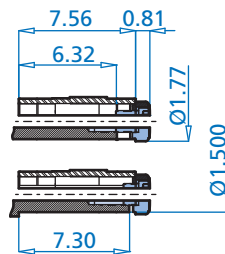

SK 92772.1AFS

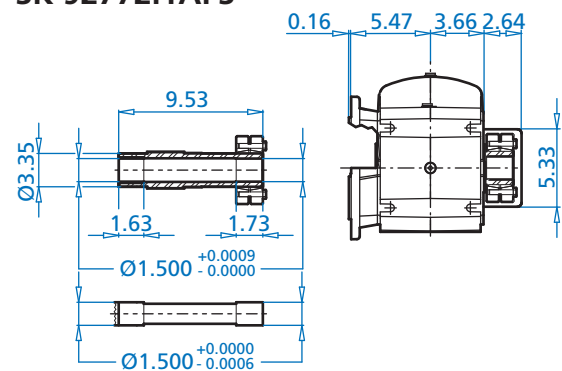

**Motor Dimensions**

	71L	80S/L	90S/L	100L/LA	112M	132S/M	For Other Connection Possibilities please see  130 & 131
Standard efficiency	71L	80S/L	90S/L	100L/LA	112M	132S/M	
Energy efficiency		80LH	90SH/LH	100LH		112MH	
Premium efficiency		80LP	90SP/LP	100LP		112MP	132SP/MP
AB	4,86	5,59	5,79	6,65	7,05	7,05	8,03
AB (BR)	5,24	5,59	5,79	6,77	7,17	7,17	7,91
C	22,47	23,45	25,03	26,25	27,12	28,11	30,54
C (BR)	24,75	25,97	27,98	29,85	30,82	31,81	34,75
FP	5,72	6,43	7,19	7,90	8,87	8,87	10,45
ZB	1,59	1,59	1,59	1,59	1,59	1,59	1,82

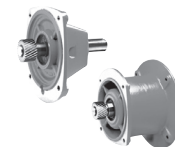

ALTERNATE SHAFTS SEE PAGES 140 - 144

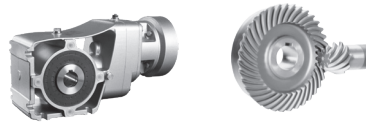

**SK 92772.1VF**

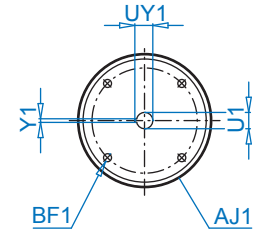
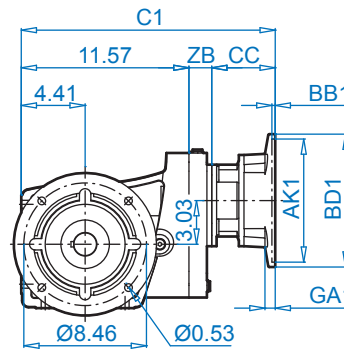
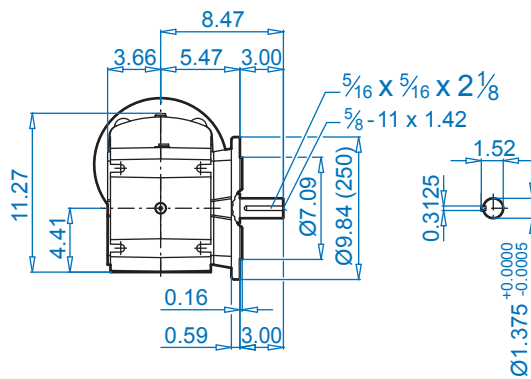

**SK 92772.1AF**

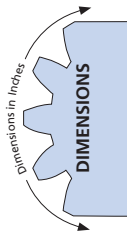
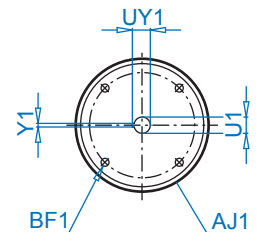
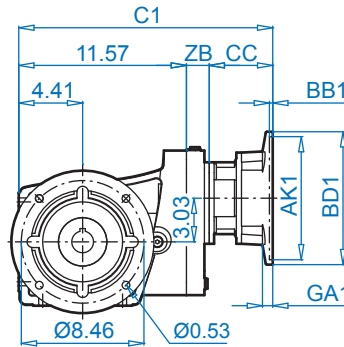
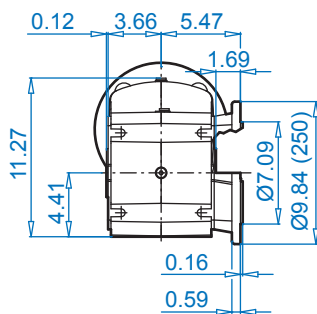

**SK 92772.1AF**

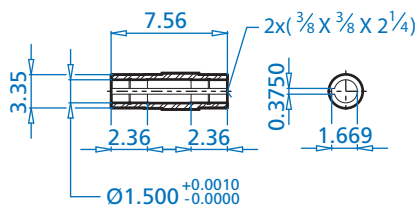

**SK 92772.1AB**

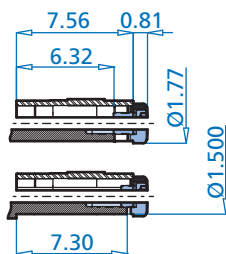

**SK 92772.1AFS**

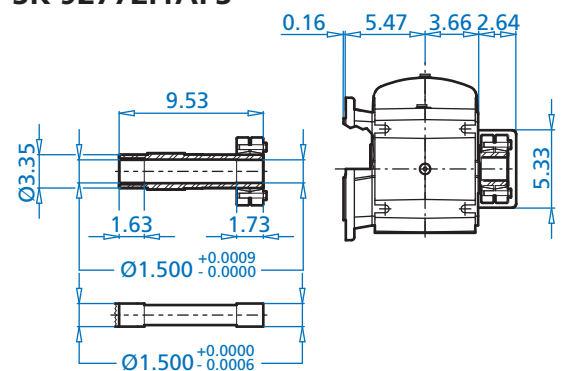

ALTERNATE SHAFTS SEE PAGES 140 - 144

**NEMA Dimensions**

Type	AJ1	AK1	BB1	BD1	BF1	GA1	U1	UY1	Y1	C1	CC	ZB
56C	5,875	4,500	0,18	6,54	0,43	0,47	0,625	0,709	0,188	16,84	3,68	1,59
140TC	5,875	4,500	0,18	6,54	0,43	0,47	0,875	0,964	0,188	17,31	4,15	1,59
180TC	7,250	8,500	0,23	9,17	0,55	0,71	1,125	1,241	0,250	17,54	4,38	1,59
210TC	7,250	8,500	0,23	9,17	0,59	0,98	1,375	1,518	0,312	18,36	4,96	1,82

# SK 93072.1 + Motor

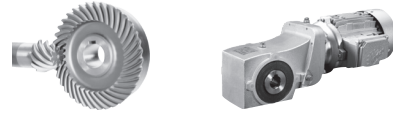

## SK 93072.1V

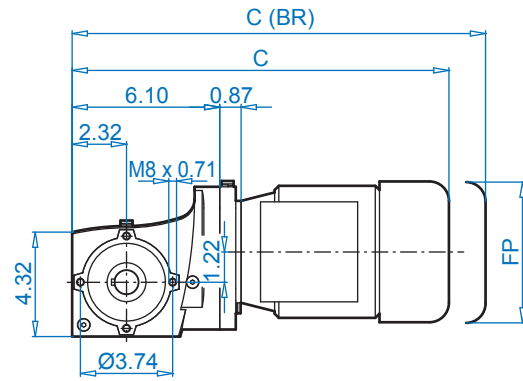
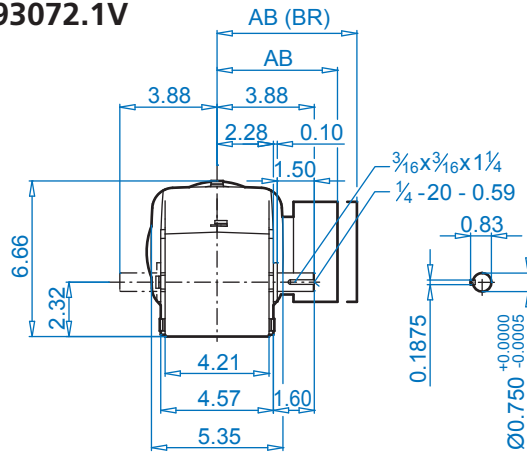

## SK 93072.1A

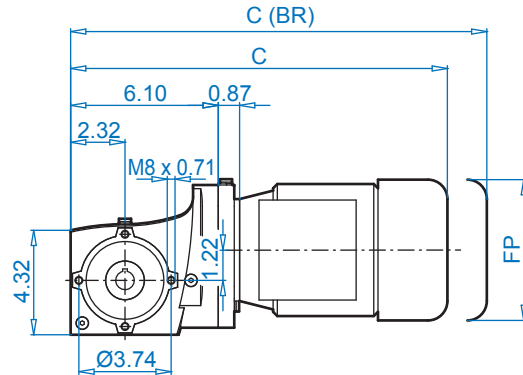
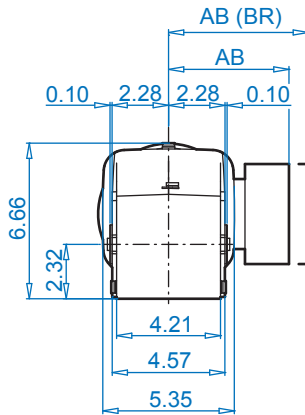

## SK 93072.1A

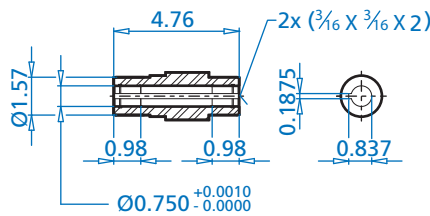

## SK 93072.1AB

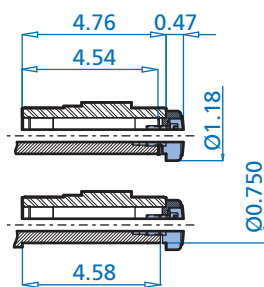

## SK 93072.1AS

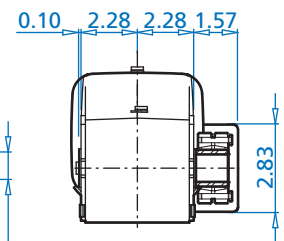
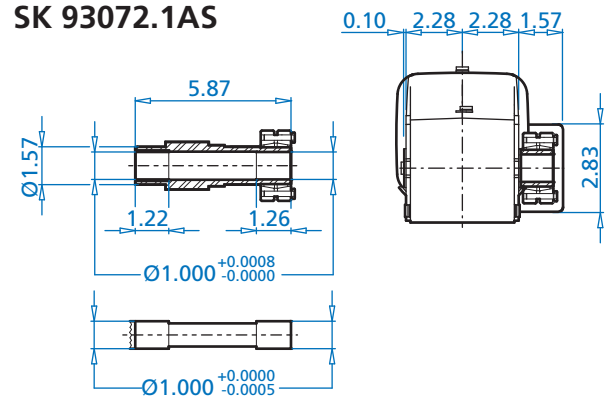

ALTERNATE SHAFTS SEE PAGES 140 - 144

### Motor Dimensions

	63S/L	71S/L	80S/L	90S	For Other Connection Possibilities please see → 130 & 131
Standard efficiency					
Energy efficiency			80LH	90SH	
Premium efficiency			80LP	90SP	
AB	4,51	4,86	5,59	5,79	
AB (BR)	4,84	5,24	5,59	5,79	
C	14,54	15,40	16,27	17,81	
C (BR)	16,74	17,69	18,79	20,76	
FP	5,09	5,72	6,43	7,19	



## SK 93072.1V

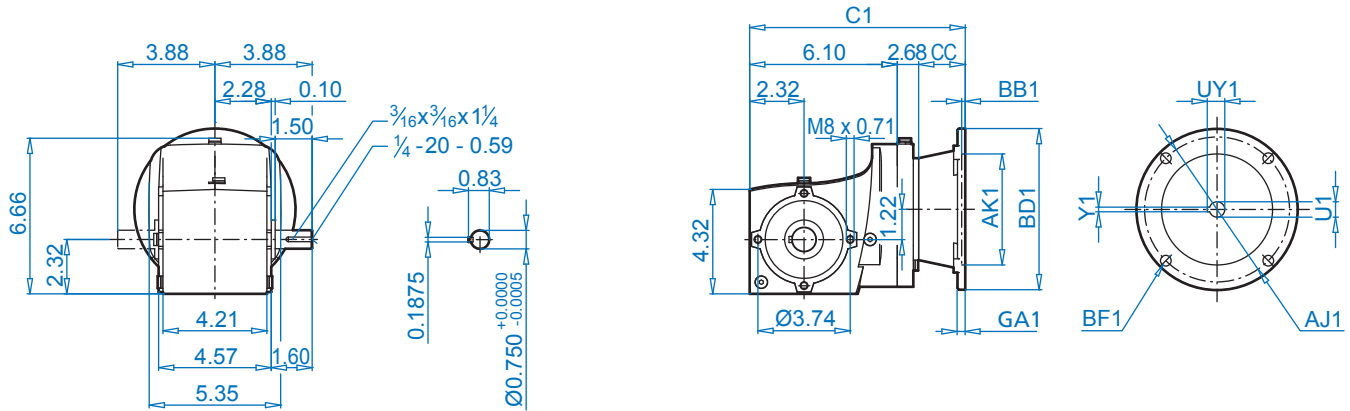

## SK 93072.1A

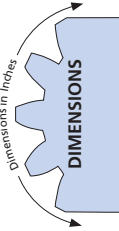
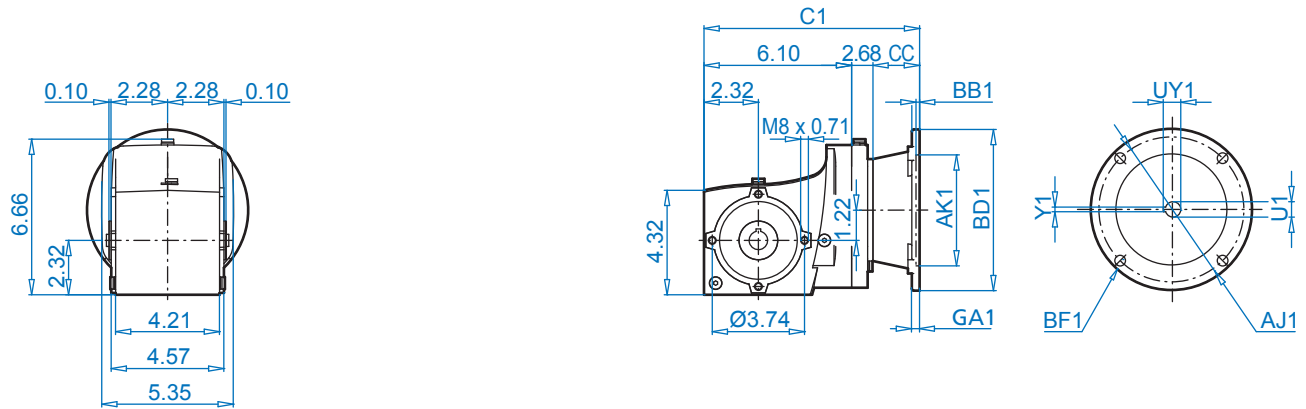

## SK 93072.1A

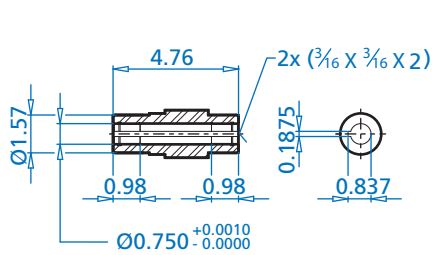

## SK 93072.1AB

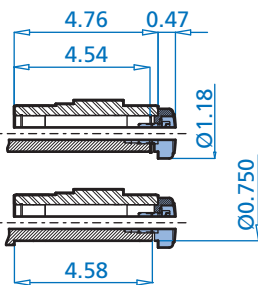

## SK 93072.1AS

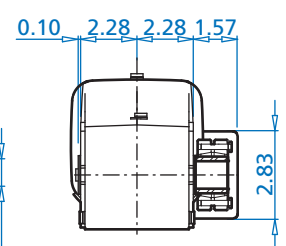
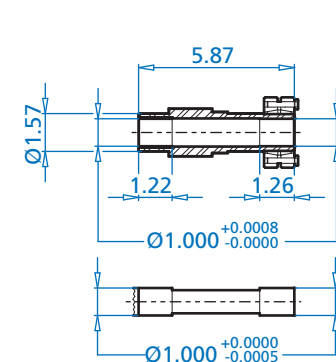

ALTERNATE SHAFTS SEE PAGES 140 - 144

### NEMA Dimensions

Type	AJ1	AK1	BB1	BD1	BF1	GA1	U1	UY1	Y1	C1	CC
56C	5,875	4,500	0,18	6,54	0,43	0,47	0,625	0,709	0,188	10,23	1,46
140TC	5,875	4,500	0,18	6,54	0,43	0,47	0,875	0,964	0,188	10,70	1,93



# SK 93072.1 + Motor

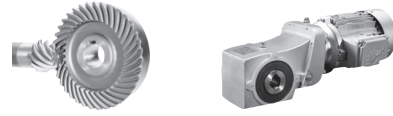

## SK 93072.1VF

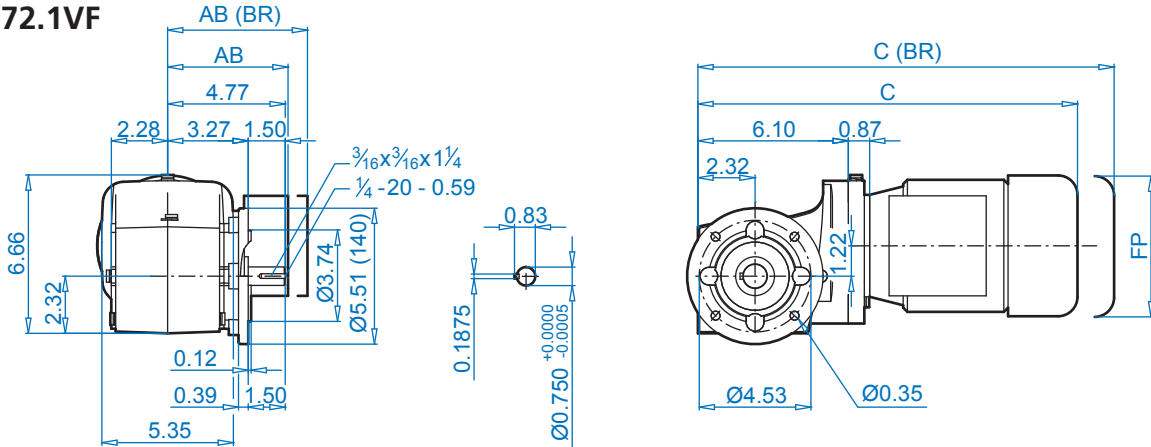

## SK 93072.1AF

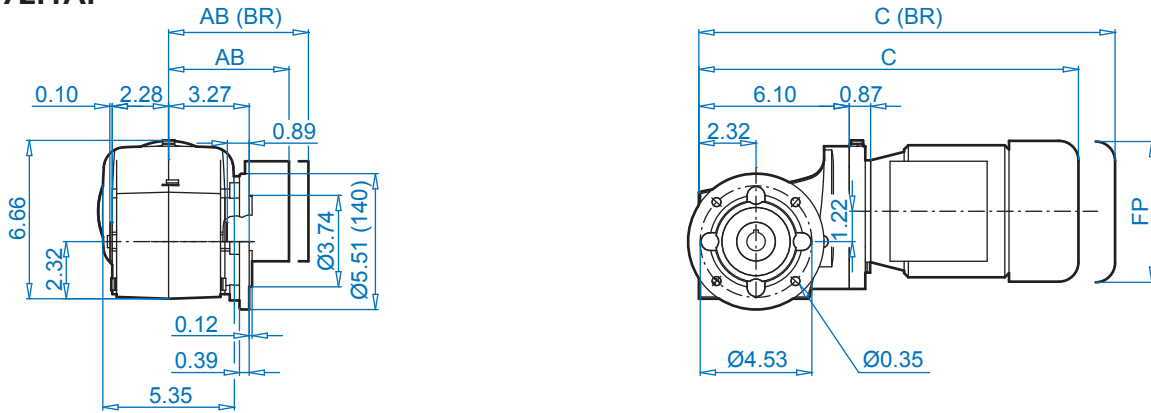

## SK 93072.1AF

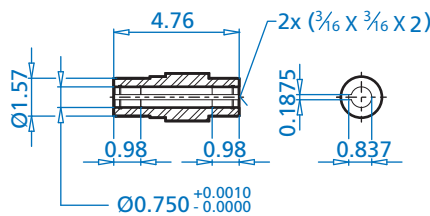

## SK 93072.1AB

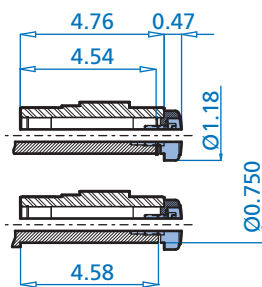

## SK 93072.1AFS

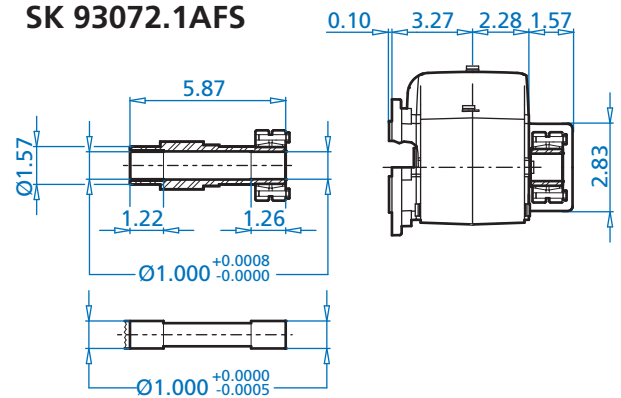

ALTERNATE SHAFTS SEE PAGES 140 - 144

### Motor Dimensions

	63S/L	71S/L	80S/L	90S	For Other Connection Possibilities please see → 130 & 131
Standard efficiency					
Energy efficiency			80LH	90SH	
Premium efficiency			80LP	90SP	
AB	4,51	4,86	5,59	5,79	
AB (BR)	4,84	5,24	5,59	5,79	
C	14,54	15,40	16,27	17,81	
C (BR)	16,74	17,69	18,79	20,76	
FP	5,09	5,72	6,43	7,19	



**SK 93072.1VF**

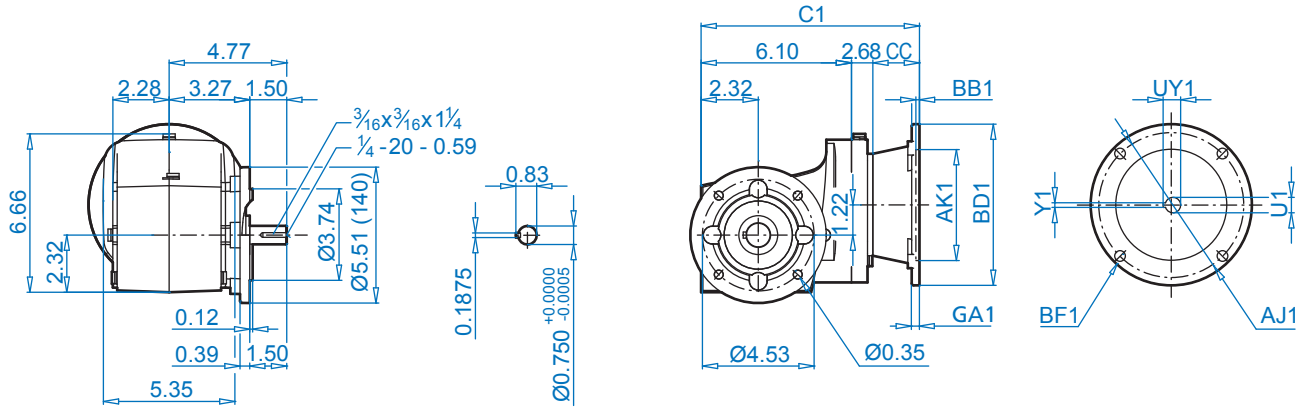

**SK 93072.1AF**

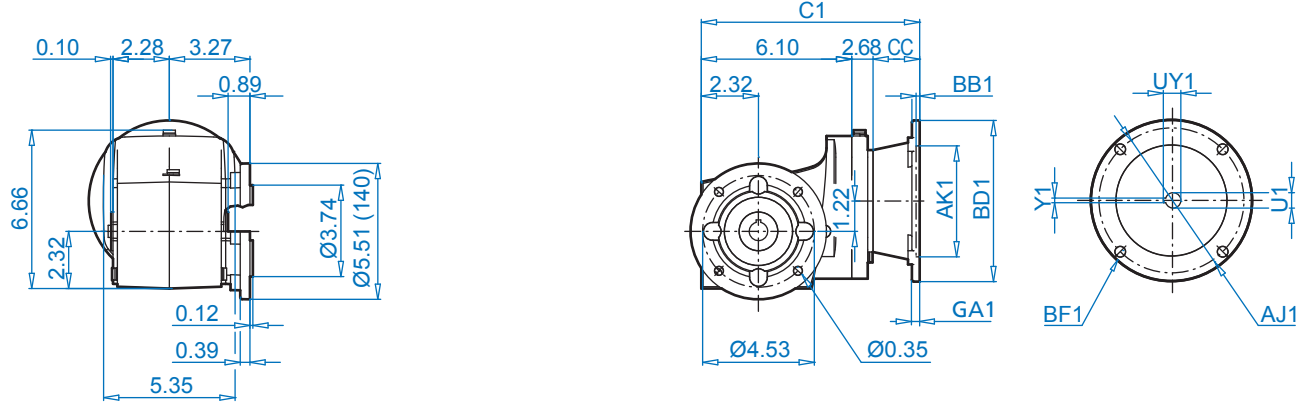

**SK 93072.1AF**

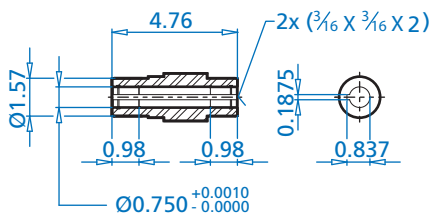

**SK 93072.1AB**

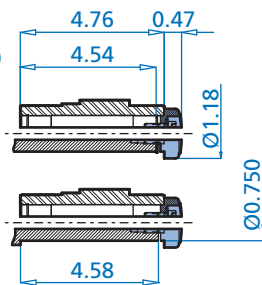

**SK 93072.1AFS**

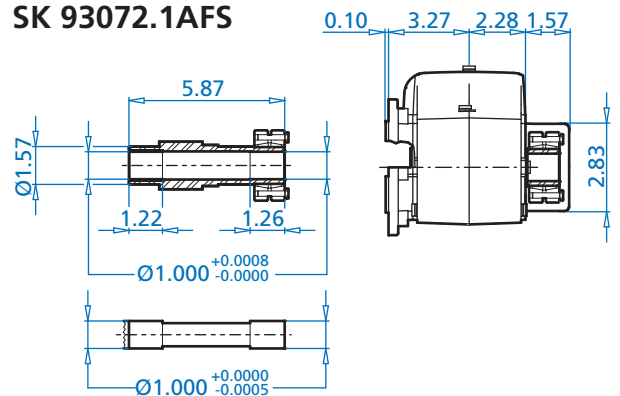

ALTERNATE SHAFTS SEE PAGES 140 - 144

**NEMA Dimensions**

Type	AJ1	AK1	BB1	BD1	BF1	GA1	U1	UY1	Y1	C1	CC
56C	5,875	4,500	0,18	6,54	0,43	0,47	0,625	0,709	0,188	10,23	1,46
140TC	5,875	4,500	0,18	6,54	0,43	0,47	0,875	0,964	0,188	10,70	1,93

# SK 93172.1 + Motor

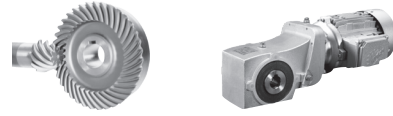

## SK 93172.1V

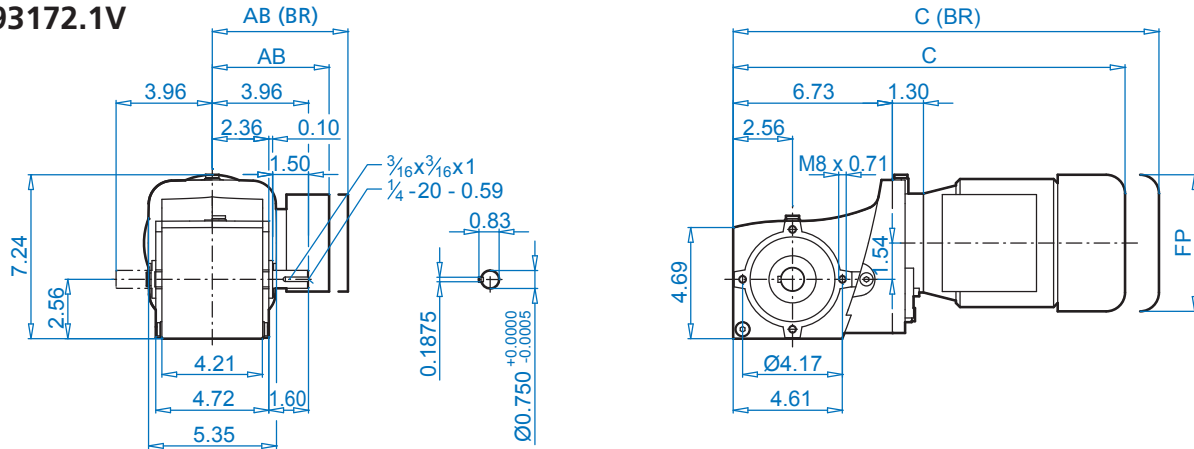

## SK 93172.1A

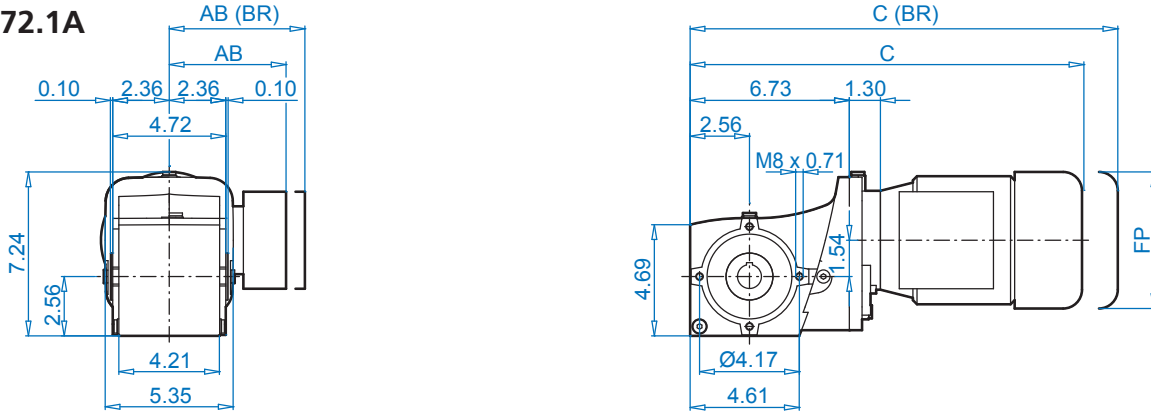

## SK 93172.1A

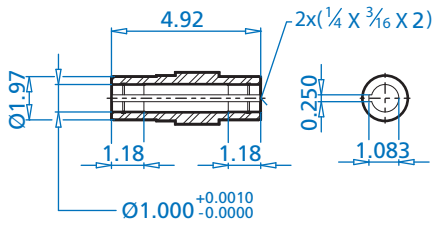

## SK 93172.1AB

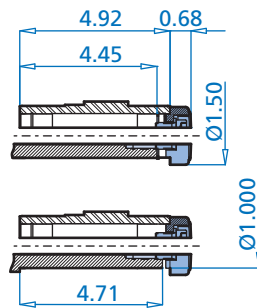

## SK 93172.1AS

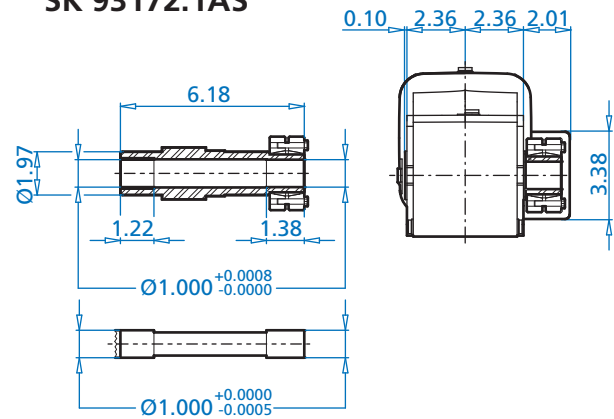

### Motor Dimensions

	63S/L	71S/L	80S/L	90S/L	For Other Connection Possibilities please see → 130 & 131
Standard efficiency	63S/L	71S/L	80S/L	90S/L	
Energy efficiency			80LH	90SH/LH	
Premium efficiency			80LP	90SP/LP	
AB	4,51	4,86	5,59	5,79	
AB (BR)	4,84	5,24	5,59	5,79	
C	15,62	16,47	17,34	18,87	
C (BR)	17,82	18,76	19,86	21,83	
FP	5,09	5,72	6,43	7,19	

ALTERNATE SHAFTS SEE PAGES 140 - 144



# SK 93172.1 + Motor

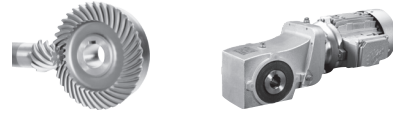

## SK 93172.1VF

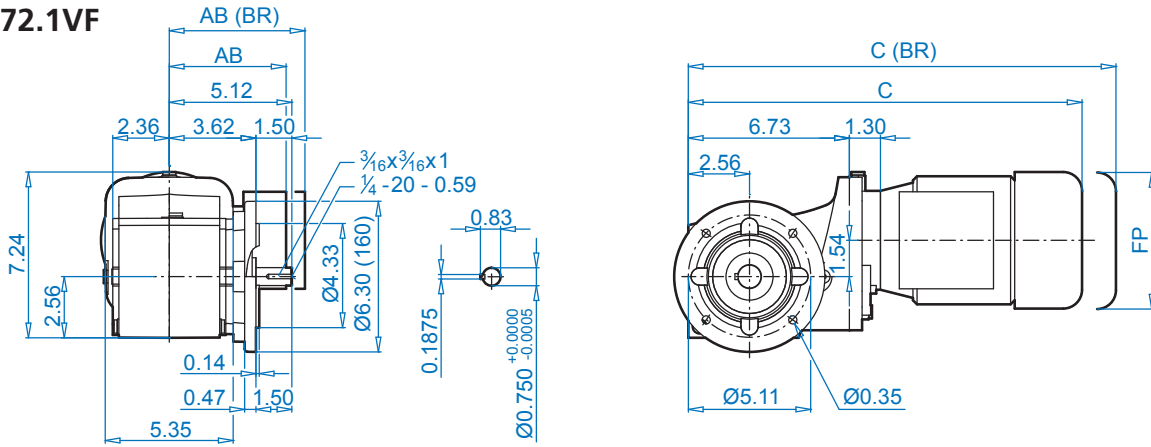

## SK 93172.1AF

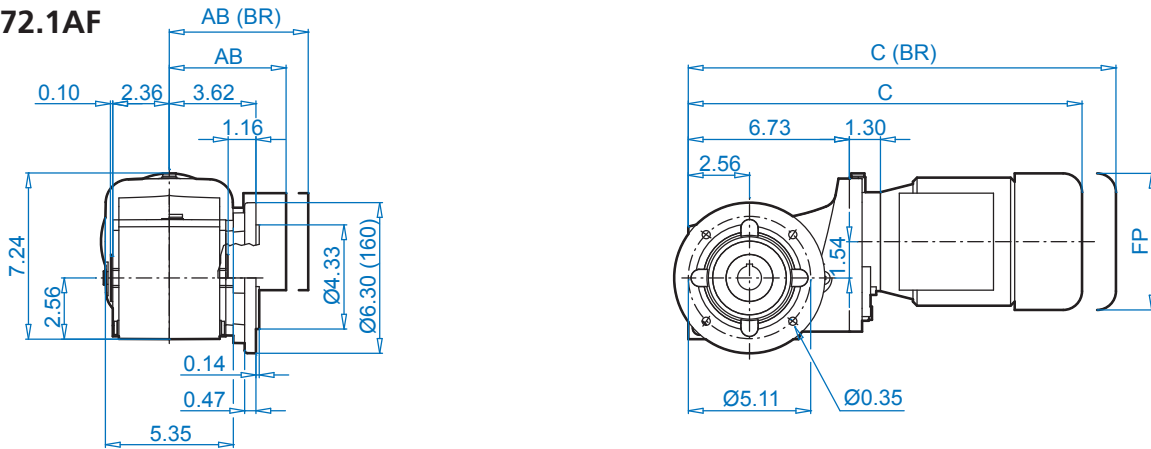

## SK 93172.1AF

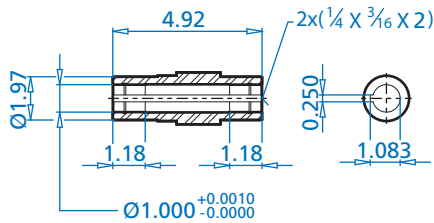

## SK 93172.1AB

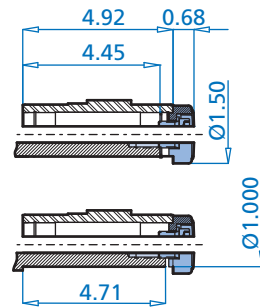

## SK 93172.1AFS

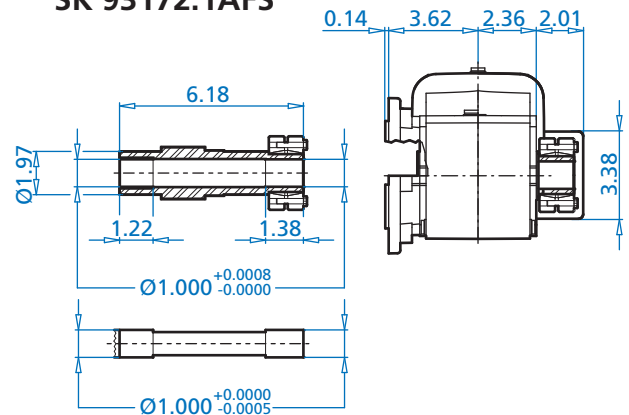

### Motor Dimensions

	63S/L	71S/L	80S/L	90S/L	For Other Connection Possibilities please see → 130 & 131
Standard efficiency					
Energy efficiency			80LH	90SH/LH	
Premium efficiency			80LP	90SP/LP	
AB	4,51	4,86	5,59	5,79	
AB (BR)	4,84	5,24	5,59	5,79	
C	15,62	16,47	17,34	18,87	
C (BR)	17,82	18,76	19,86	21,83	
FP	5,09	5,72	6,43	7,19	

ALTERNATE SHAFTS SEE PAGES 140 - 144



## SK 93172.1VF

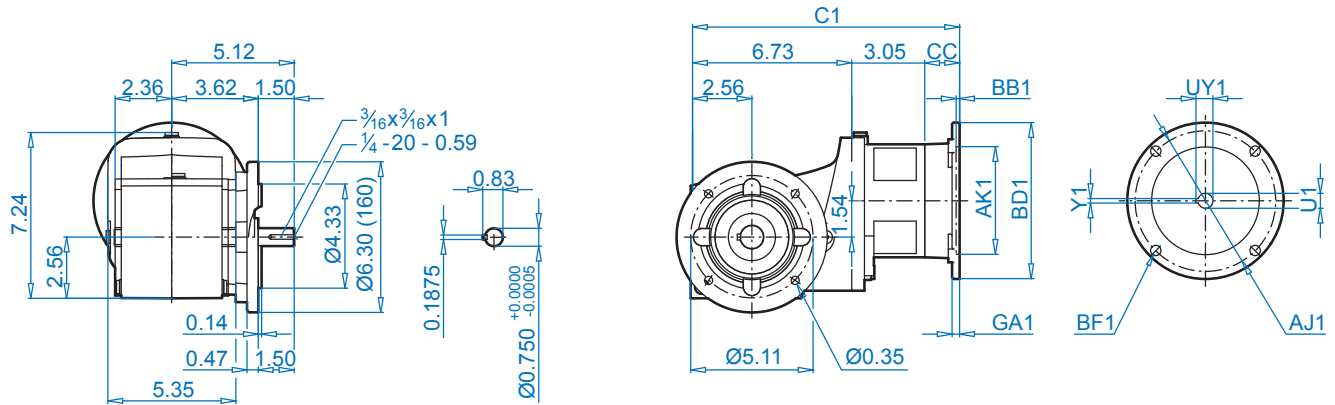

## SK 93172.1AF

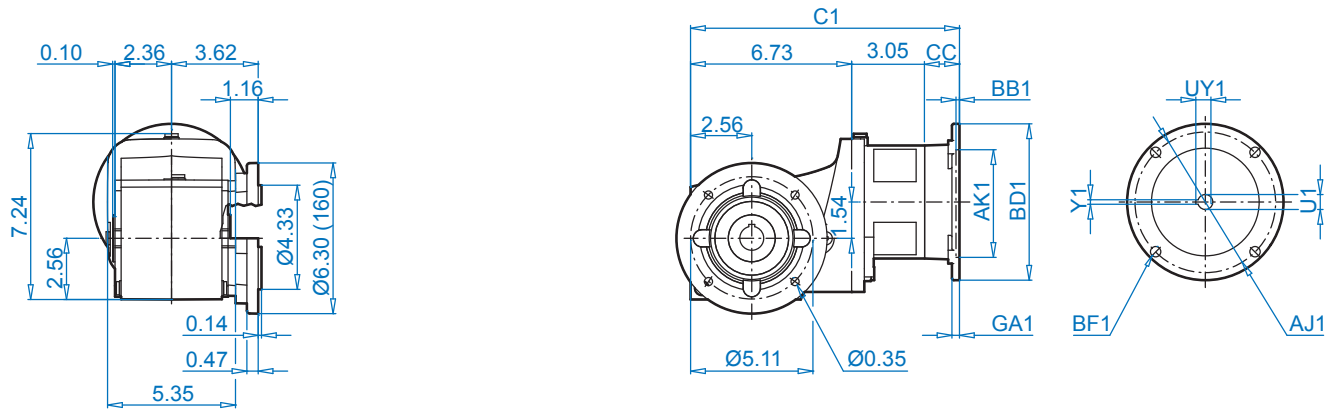

## SK 93172.1AF

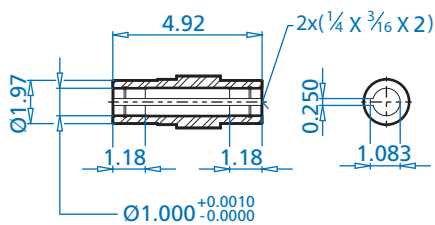

## SK 93172.1AB

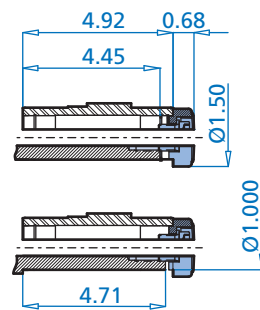

## SK 93172.1AFS

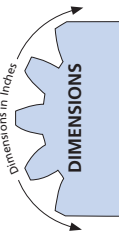
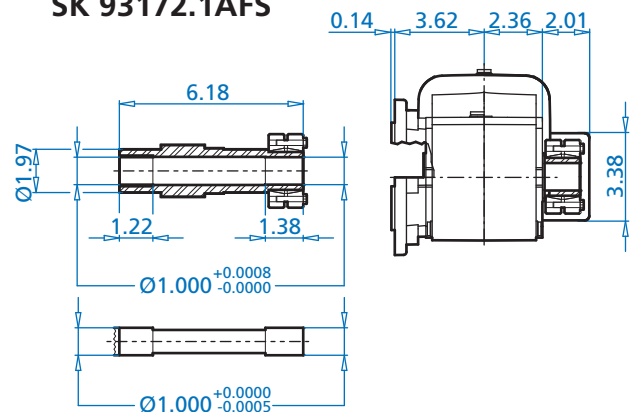

ALTERNATE SHAFTS SEE PAGES 140 - 144

### NEMA Dimensions

Type	AJ1	AK1	BB1	BD1	BF1	GA1	U1	UY1	Y1	C1	CC
56C	5,875	4,500	0,18	6,54	0,43	0,47	0,625	0,709	0,188	11,24	1,46
140TC	5,875	4,500	0,18	6,54	0,43	0,47	0,875	0,964	0,188	11,71	1,93



# SK 93372.1+ Motor

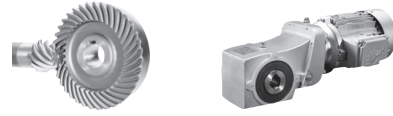

## SK 93372.1V

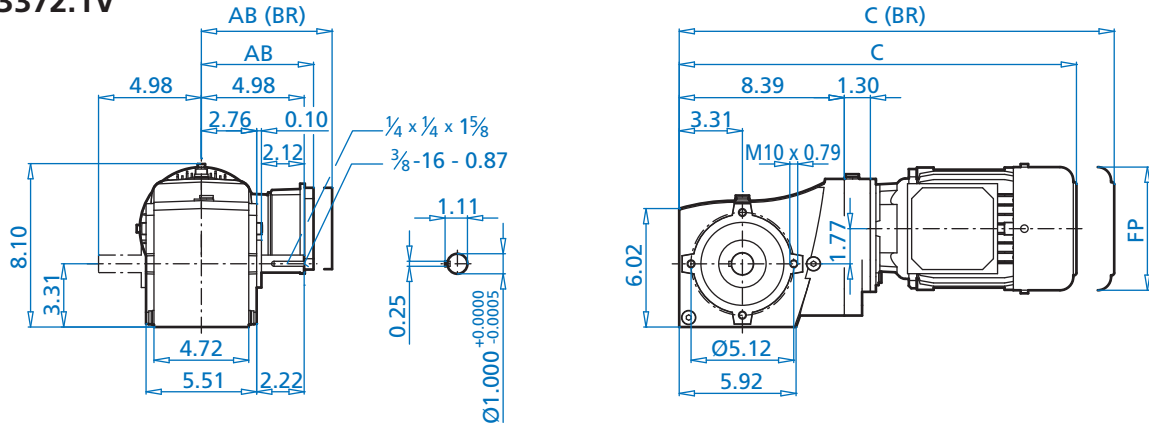

## SK 93372.1A

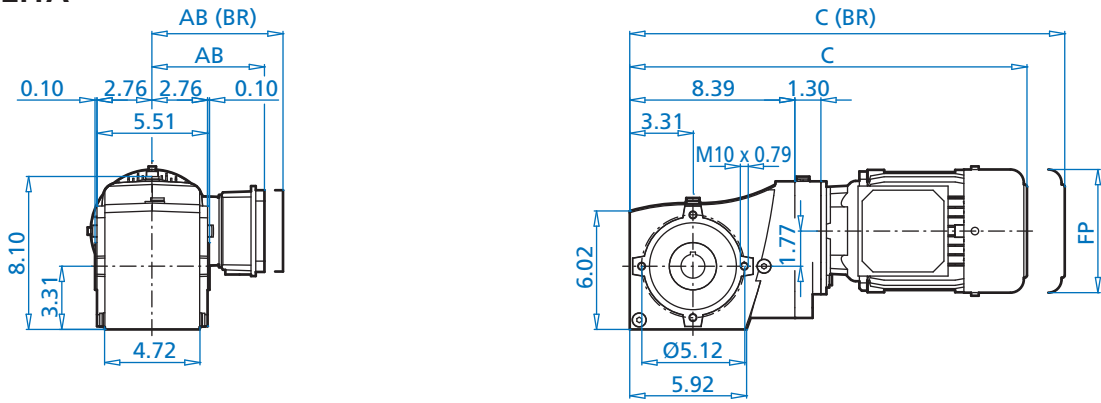

## SK 93372.1A

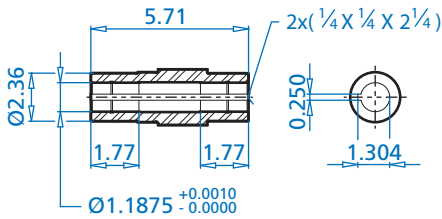

## SK 93372.1AB

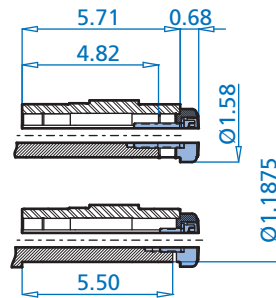

## SK 93372.1AS

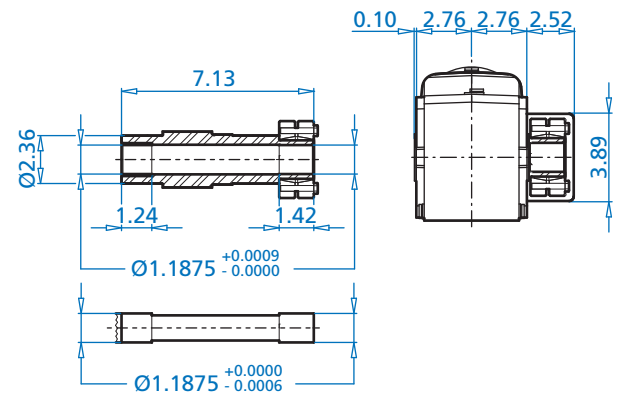

ALTERNATE SHAFTS SEE PAGES 140 - 144

### Motor Dimensions

	63S/L	71S/L	80S/L	90S/L	100L/LA	112M	
Standard efficiency	63S/L	71S/L	80S/L	90S/L	100L/LA	112M	
Energy efficiency			80LH	90SH/LH	100LH		112MH
Premium efficiency			80LP	90SP/LP	100LP		112MP
AB	4,51	4,86	5,59	5,79	6,65	7,05	7,05
AB (BR)	4,84	5,24	5,59	5,79	6,77	7,17	7,17
C	17,42	18,99	19,98	21,55	22,77	23,64	24,63
C (BR)	19,62	21,28	22,50	24,5	26,37	27,34	28,33
FP	5,09	5,72	6,43	7,19	7,90	8,87	8,87

For Other Connection Possibilities please see ⇨ 130 & 131

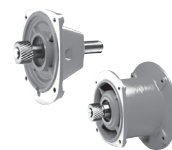



**SK 93372.1V**

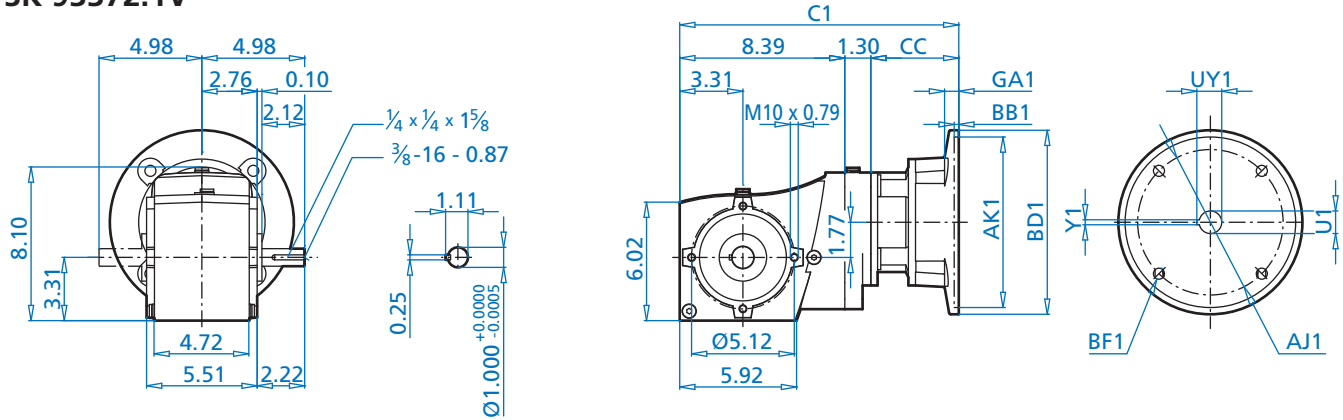

**SK 93372.1A**

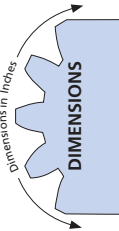
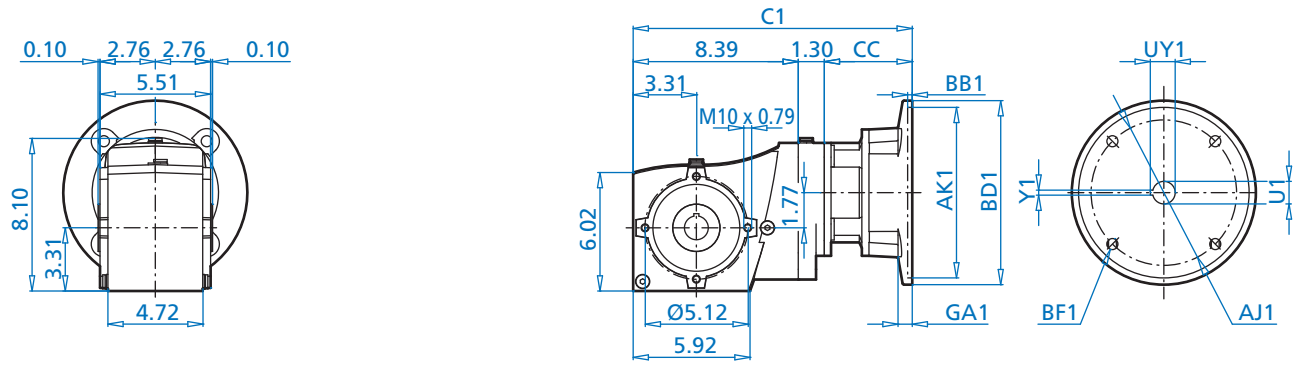

**SK 93372.1A**

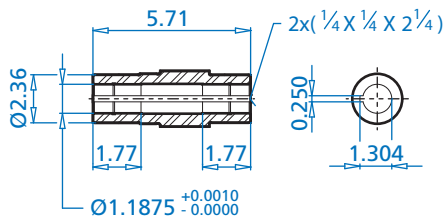

**SK 93372.1AB**

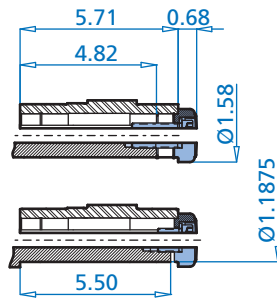

**SK 93372.1AS**

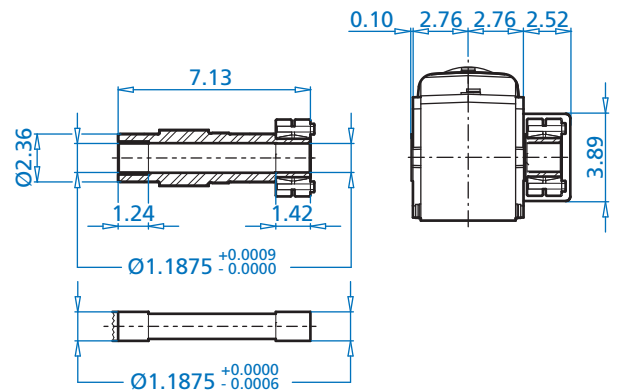

ALTERNATE SHAFTS SEE PAGES 140 - 144

**NEMA Dimensions**

Type	AJ1	AK1	BB1	BD1	BF1	GA1	U1	UY1	Y1	C1	CC
56C	5,875	4,500	0,18	6,54	0,43	0,47	0,625	0,709	0,188	13,37	3,68
140TC	5,875	4,500	0,18	6,54	0,43	0,47	0,875	0,964	0,188	13,84	4,15
180TC	7,250	8,500	0,23	9,17	0,55	0,71	1,125	1,241	0,250	14,07	4,38

# SK 93372.1 + Motor

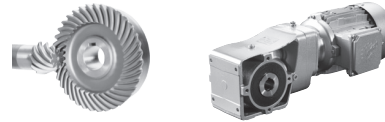

## SK 93372.1VF

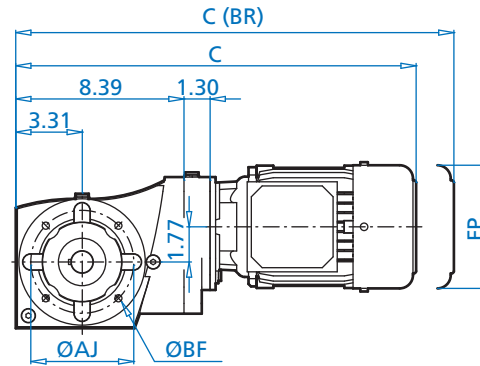
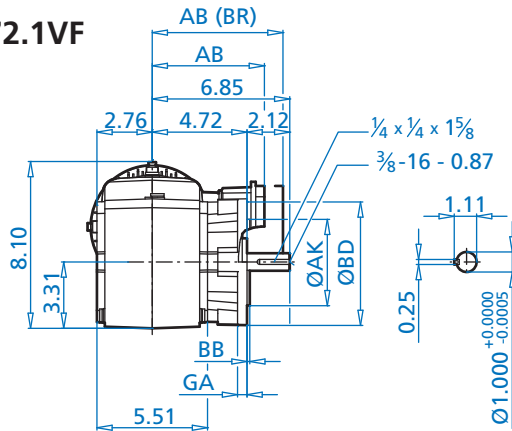

## SK 93372.1AF

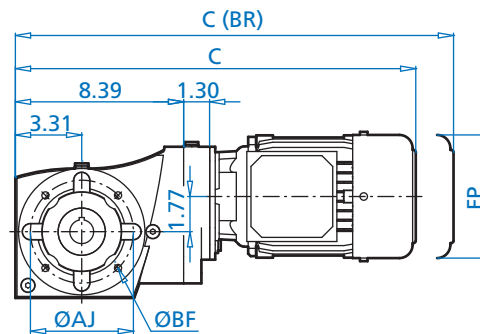
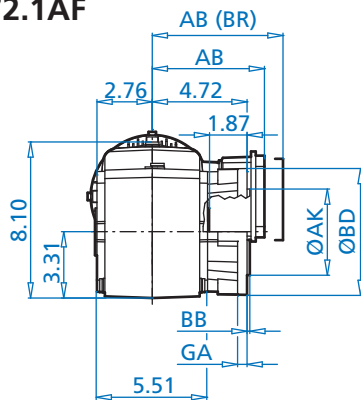

## SK 93372.1AF

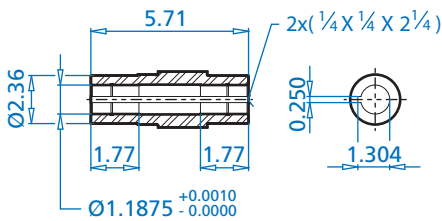

## SK 93372.1AB

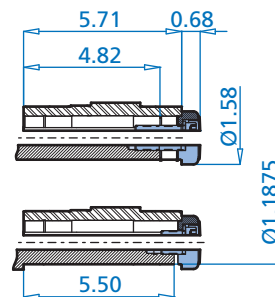

## SK 93372.1AFS

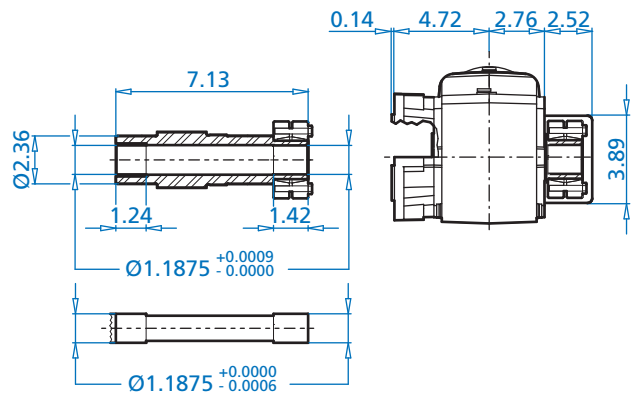

### Mounting flange

BD (mm)	AJ	AK	BB	BF	GA
6.30 (160)	5.12	4.331 +0.0005 -0.0004	0.14	0.35	0.47
7.87 (200)	6.50	5.118 +0.0005 -0.0004	0.14	0.43	0.47

### Motor Dimensions

Standard efficiency	63S/L	71S/L	80S/L	90S/L	100L/LA	112M	112MH	For Other Connection Possibilities please see → 130 & 131
Energy efficiency			80LH	90SH/LH	100LH			
Premium efficiency			80LP	90SP/LP	100LP		112MP	
AB		4,51	4,86	5,59	5,79	6,65	7,05	
AB (BR)		4,84	5,24	5,59	5,79	6,77	7,17	
C		17,42	18,99	19,98	21,55	22,77	23,64	24,63
C (BR)		19,62	21,28	22,50	24,5	26,37	27,34	28,33
FP		5,09	5,72	6,43	7,19	7,90	8,87	8,87

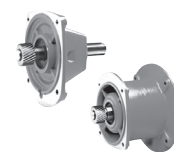

ALTERNATE SHAFTS SEE PAGES 140 - 144



# SK 93672.1 + Motor

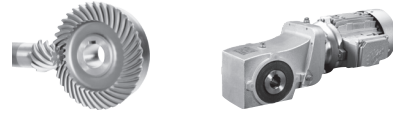

## SK 93672.1V

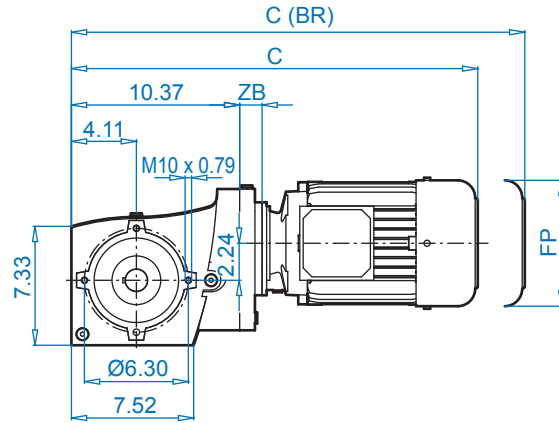
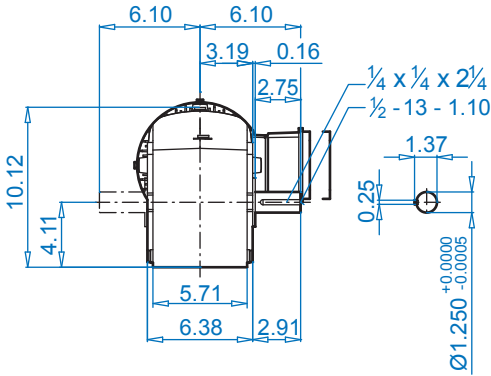

## SK 93672.1A

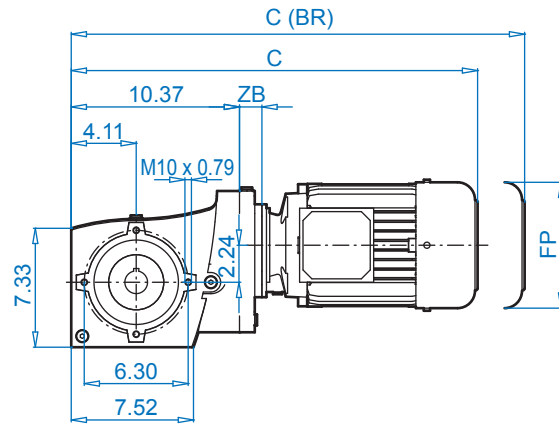
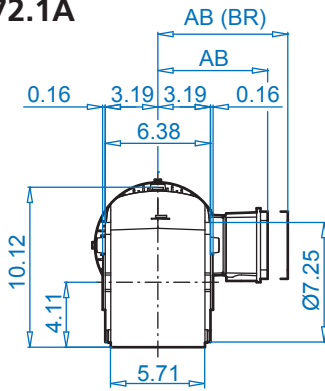

## SK 93672.1A

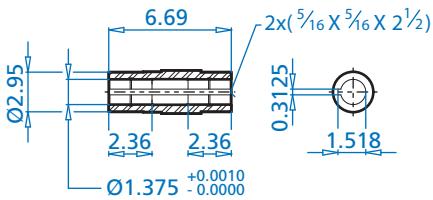

## SK 93672.1AB

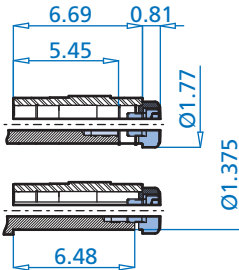

## SK 93672.1AS

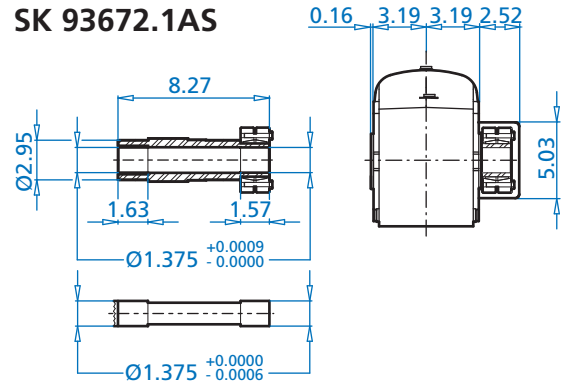

ALTERNATE SHAFTS SEE PAGES 140 - 144

### Motor Dimensions

	71S/L	80S/L	90S/L	100L/LA	112M	132S/M	For Other Connection Possibilities please see ⇨ 130 & 131
Standard efficiency	71S/L	80S/L	90S/L	100L/LA	112M	132S/M	
Energy efficiency		80LH	90SH/LH	100LH		112MH	
Premium efficiency		80LP	90SP/LP	100LP		112MP	132SP/LP
AB	4,86	5,59	5,79	6,65	7,05	7,05	8,03
AB (BR)	5,24	5,59	5,79	6,77	7,17	7,17	7,91
C	21,05	22,04	23,61	24,83	25,70	26,69	29,12
C (BR)	23,33	24,56	26,56	28,43	29,4	30,39	33,33
FP	5,72	6,43	7,19	7,90	8,87	8,87	10,45
ZB	1,37	1,37	1,37	1,37	1,37	1,37	1,61

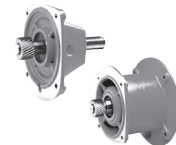



## SK 93672.1V

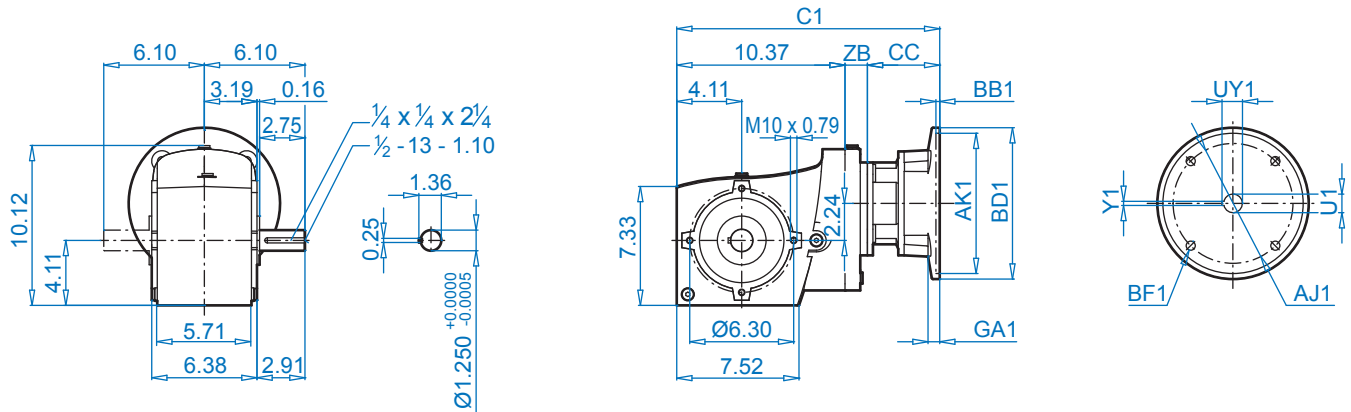

## SK 93672.1A

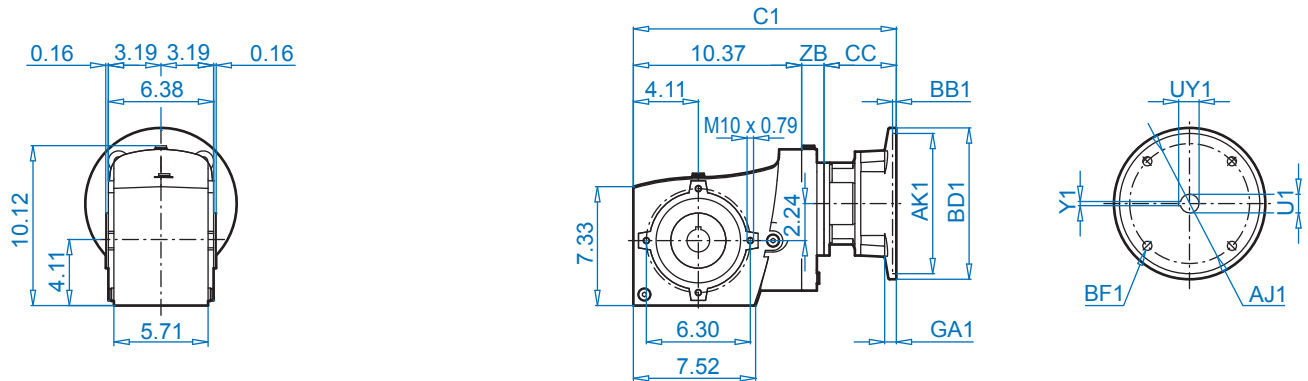

## SK 93672.1A

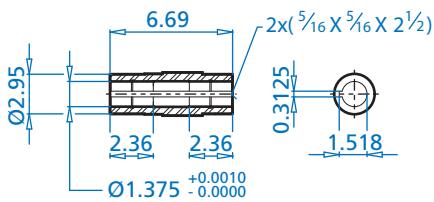

## SK 93672.1AB

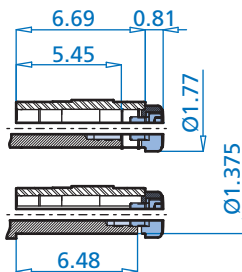

## SK 93672.1AS

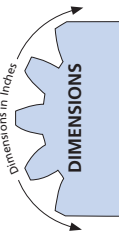
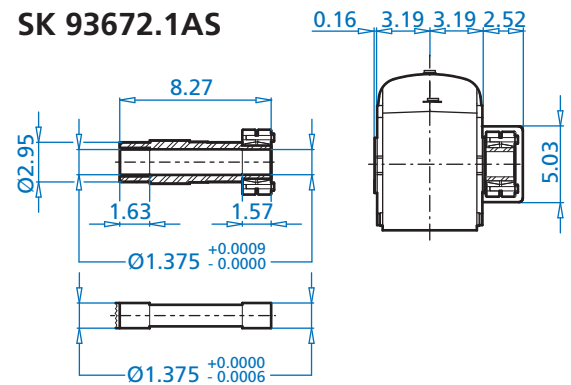

ALTERNATE SHAFTS SEE PAGES 140 - 144

### NEMA Dimensions

Type	AJ1	AK1	BB1	BD1	BF1	GA1	U1	UY1	Y1	C1	CC	ZB
56C	5,875	4,500	0,18	6,54	0,43	0,47	0,625	0,709	0,188	15,43	3,68	1,37
140TC	5,875	4,500	0,18	6,54	0,43	0,47	0,875	0,964	0,188	15,90	4,15	1,37
180TC	7,250	8,500	0,23	9,17	0,55	0,71	1,125	1,241	0,250	16,13	4,38	1,37
210TC	7,250	8,500	0,23	9,17	0,59	0,98	1,375	1,518	0,312	16,94	4,96	1,61



# SK 93672.1 + Motor

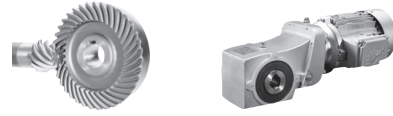

## SK 93672.1VF

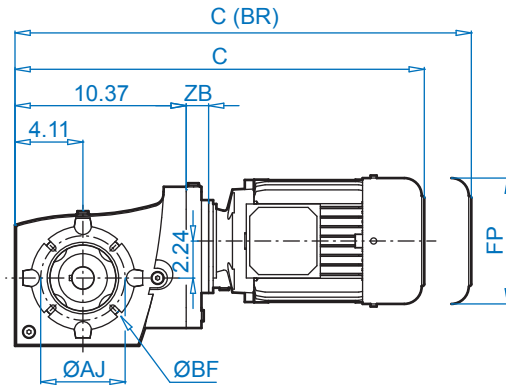
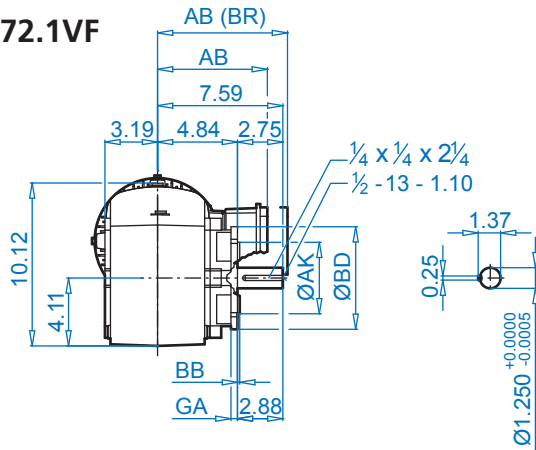

## SK 93672.1AF

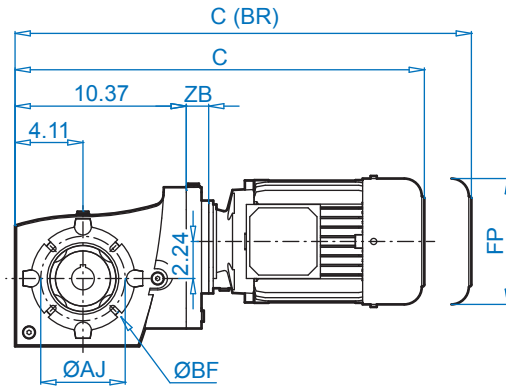
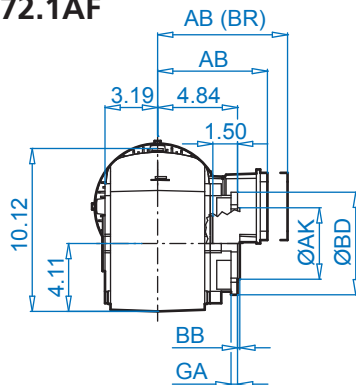

DIMENSIONS  
Dimensions in inches

## SK 93672.1AF

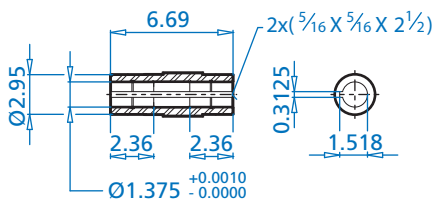

## SK 93672.1AB

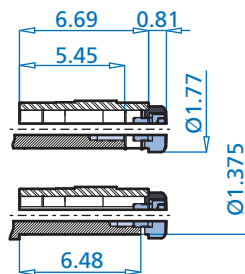

## SK 93672.1AFS

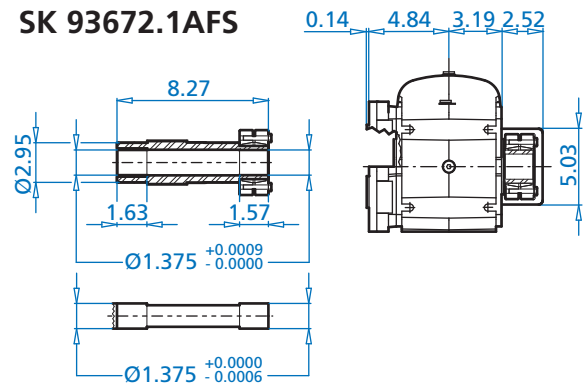

### Mounting flange

BD (mm)	AJ	AK	BB	BF	GA
6.30 (160)	5.12	4.331 +0.0005 -0.0004	0.14	0.35	0.39
7.87 (200)	6.50	5.118 +0.0006 -0.0004	0.14	0.43	0.47

### Motor Dimensions

	71S/L	80S/L	90S/L	100L/LA	112M	132S/M	For Other Connection Possibilities please see ⇨ 130 & 131
Standard efficiency							
Energy efficiency		80LH	90SH/LH	100LH		112MH 132SH/MH	
Premium efficiency		80LP	90SP/LP	100LP		112MP 132SP/LP	
AB	4,86	5,59	5,79	6,65	7,05	7,05	8,03
AB (BR)	5,24	5,59	5,79	6,77	7,17	7,17	7,91
C	21,05	22,04	23,61	24,83	25,70	26,69	29,12
C (BR)	23,33	24,56	26,56	28,43	29,4	30,39	33,33
FP	5,72	6,43	7,19	7,90	8,87	8,87	10,45
ZB	1,37	1,37	1,37	1,37	1,37	1,37	1,61

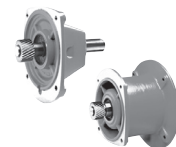

ALTERNATE SHAFTS SEE PAGES 140 - 144



## SK 93672.1VF

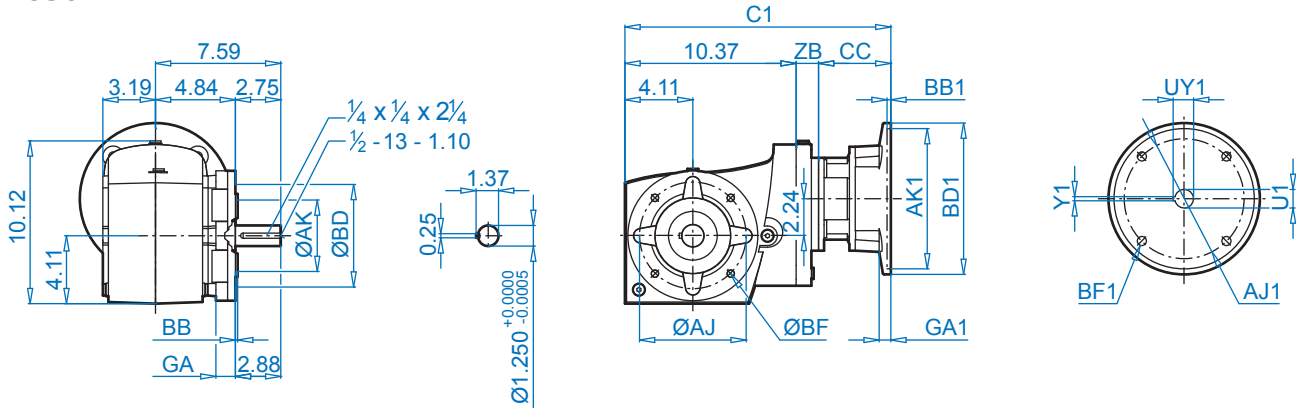

## SK 93672.1AF

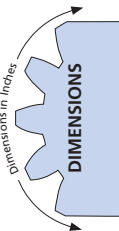
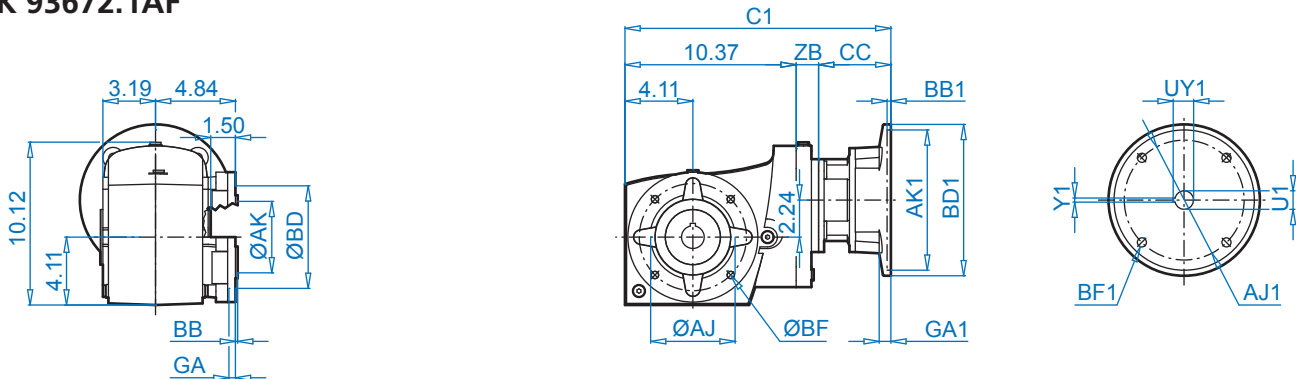

## SK 93672.1AF

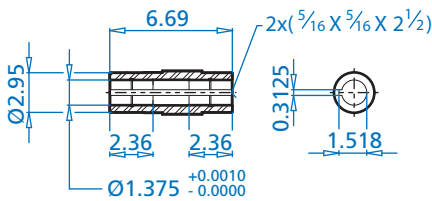

## SK 93672.1AB

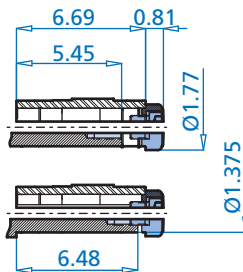

## SK 93672.1AFS

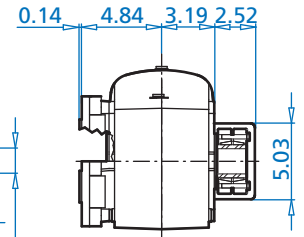
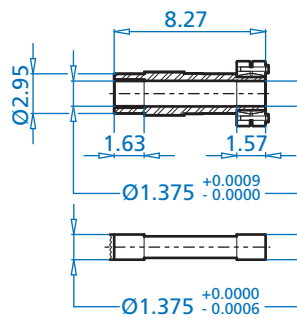

### Mounting flange

BD (mm)	AJ	AK	BB	BF	GA
6.30 (160)	5.12	4.331 <sup>+0.0005</sup> / <sub>-0.0004</sub>	0.14	0.35	0.39
7.87 (200)	6.50	5.118 <sup>+0.0006</sup> / <sub>-0.0004</sub>	0.14	0.43	0.47

### NEMA Dimensions

Type	AJ1	AK1	BB1	BD1	BF1	GA1	U1	UY1	Y1	C1	CC	ZB
56C	5,875	4,500	0,18	6,54	0,43	0,47	0,625	0,709	0,188	15,43	3,68	1,37
140TC	5,875	4,500	0,18	6,54	0,43	0,47	0,875	0,964	0,188	15,90	4,15	1,37
180TC	7,250	8,500	0,23	9,17	0,55	0,71	1,125	1,241	0,250	16,13	4,38	1,37
210TC	7,250	8,500	0,23	9,17	0,59	0,98	1,375	1,518	0,312	16,94	4,96	1,61

ALTERNATE SHAFTS SEE PAGES 140 - 144

# SK 93772.1 + Motor

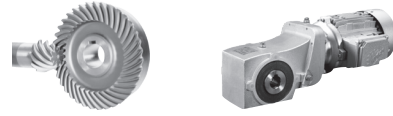

## SK 93772.1V

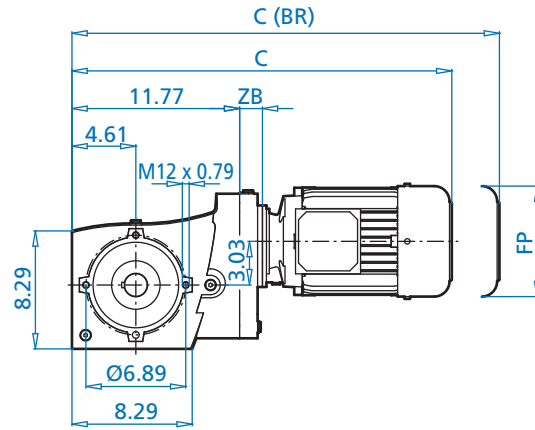
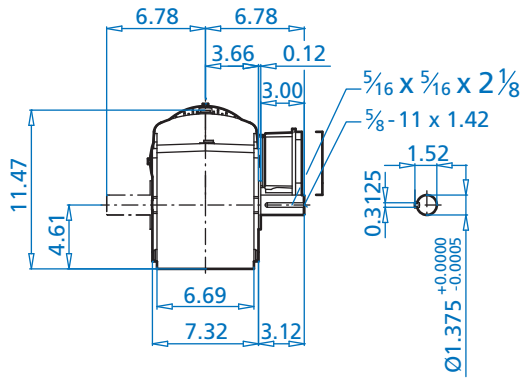

## SK 93772.1A

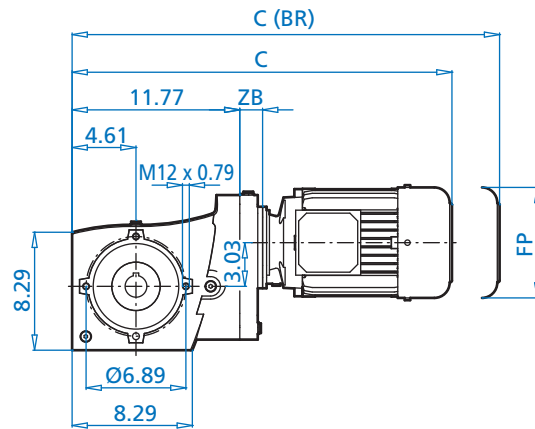
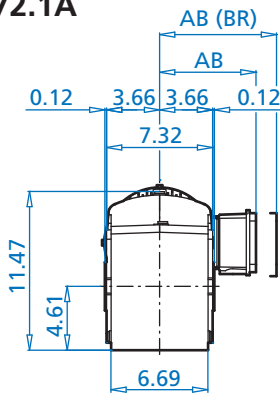

## SK 93772.1A

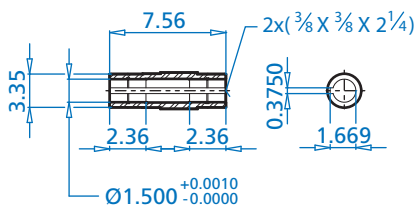

## SK 93772.1AB

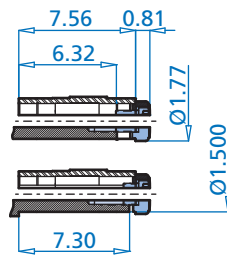

## SK 93772.1AS

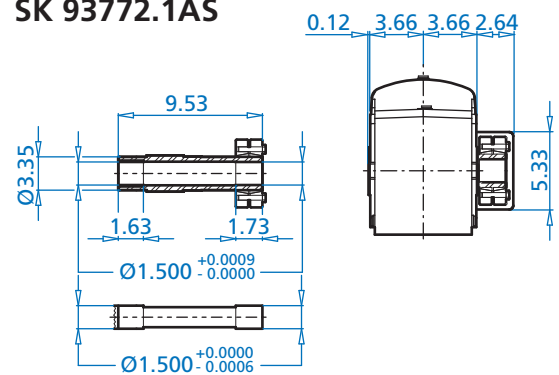

ALTERNATE SHAFTS SEE PAGES 140 - 144

### Motor Dimensions

	71L	80S/L	90S/L	100L/LA	112M	132S/M	For Other Connection Possibilities please see ⇨ 130 & 131
Standard efficiency	71L	80S/L	90S/L	100L/LA	112M	132S/M	
Energy efficiency		80LH	90SH/LH	100LH	112MH	132SH/MH	
Premium efficiency		80LP	90SP/LP	100LP	112MP	132SP/LP	
AB	4,86	5,59	5,79	6,65	7,05	7,05	8,03
AB (BR)	5,24	5,59	5,79	6,77	7,17	7,17	7,91
C	22,67	23,65	25,22	26,44	27,31	28,31	30,74
C (BR)	24,95	26,17	28,18	30,05	31,02	32,01	34,95
FP	5,72	6,43	7,19	7,90	8,87	8,87	10,45
ZB	1,59	1,59	1,59	1,59	1,59	1,59	1,82

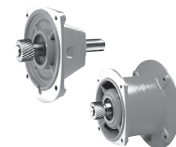



## SK 93772.1V

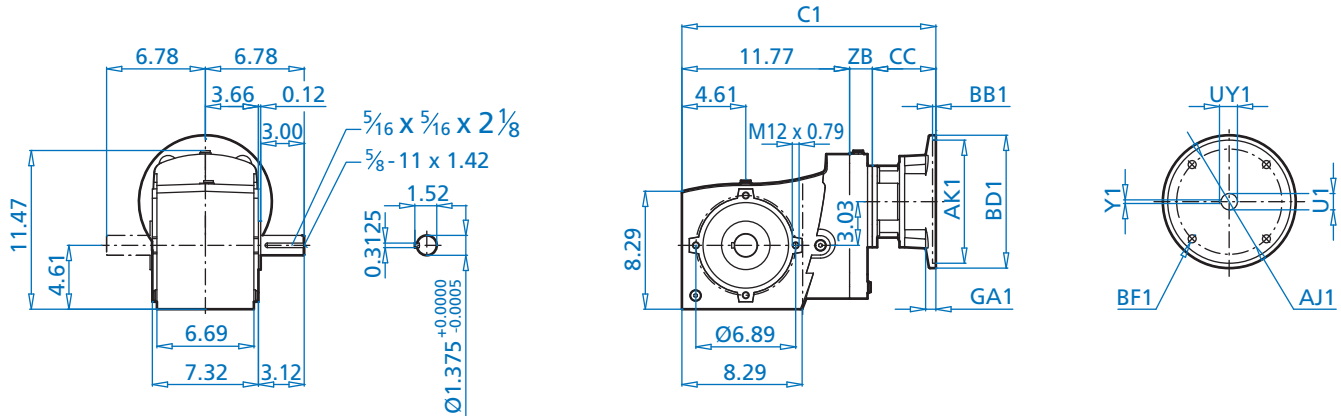

## SK 93772.1A

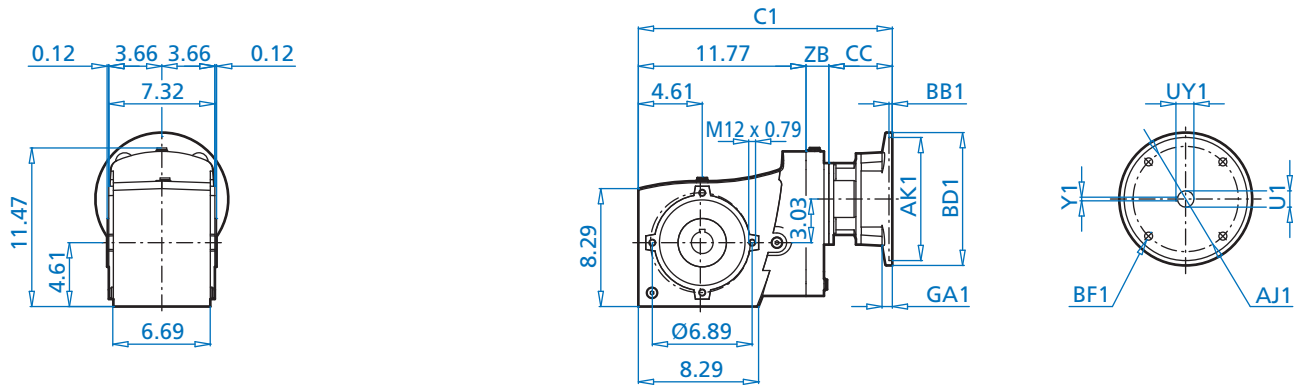

## SK 93772.1A

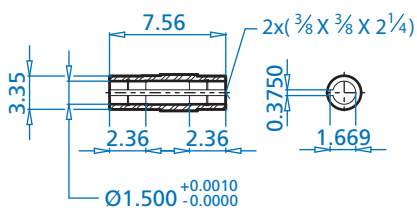

## SK 93772.1AB

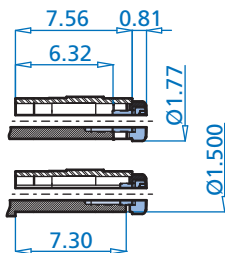

## SK 93772.1AS

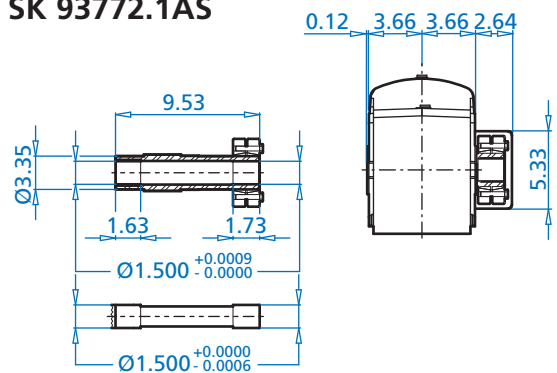

ALTERNATE SHAFTS SEE PAGES 140 - 144

### NEMA Dimensions

Type	AJ1	AK1	BB1	BD1	BF1	GA1	U1	UY1	Y1	C1	CC	ZB
56C	5,875	4,500	0,18	6,54	0,43	0,47	0,625	0,709	0,188	17,04	3,68	1,59
140TC	5,875	4,500	0,18	6,54	0,43	0,47	0,875	0,964	0,188	17,51	4,15	1,59
180TC	7,250	8,500	0,23	9,17	0,55	0,71	1,125	1,241	0,250	17,74	4,38	1,59
210TC	7,250	8,500	0,23	9,17	0,59	0,98	1,375	1,518	0,312	18,56	4,96	1,82

# SK 93772.1 + Motor

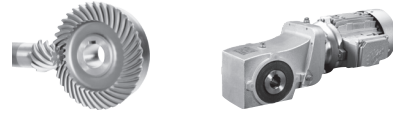

## SK 93772.1VF

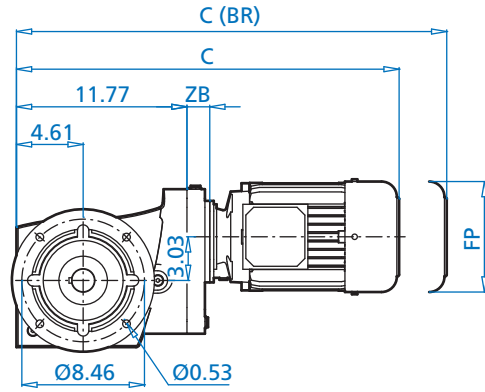
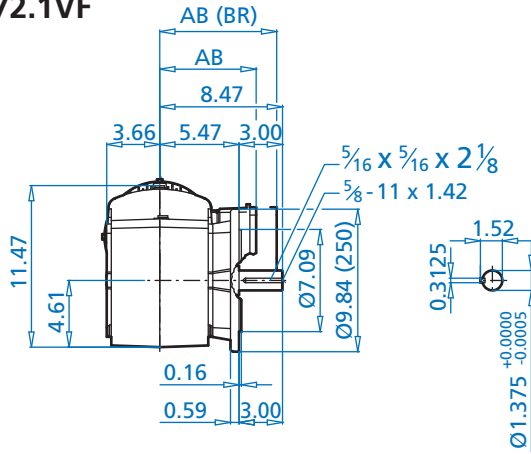

## SK 93772.1AF

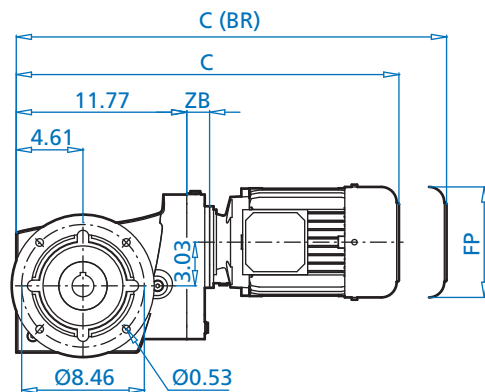
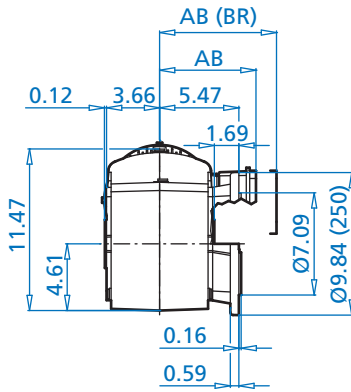

## SK 93772.1AF

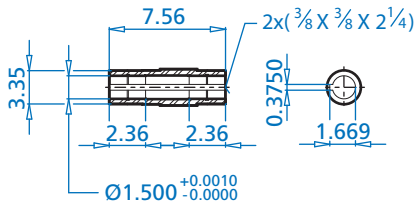

## SK 93772.1AB

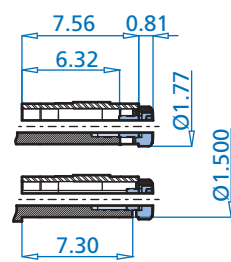

## SK 93772.1AFS

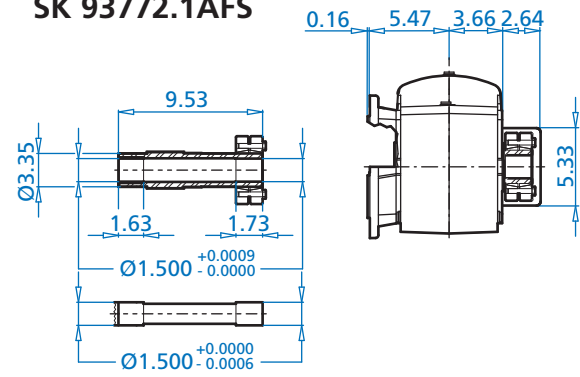

ALTERNATE SHAFTS SEE PAGES 140 - 144

### Motor Dimensions

Standard efficiency	71L	80S/L	90S/L	100L/LA	112M		132S/M	For Other Connection Possibilities please see ⇨ 130 & 131
Energy efficiency		80LH	90SH/LH	100LH		112MH	132SH/MH	
Premium efficiency		80LP	90SP/LP	100LP		112MP	132SP/LP	
AB	4,86	5,59	5,79	6,65	7,05	7,05	8,03	
AB (BR)	5,24	5,59	5,79	6,77	7,17	7,17	7,91	
C	22,67	23,65	25,22	26,44	27,31	28,31	30,74	
C (BR)	24,95	26,17	28,18	30,05	31,02	32,01	34,95	
FP	5,72	6,43	7,19	7,90	8,87	8,87	10,45	
ZB	1,59	1,59	1,59	1,59	1,59	1,59	1,82	



**SK 93772.1VF**

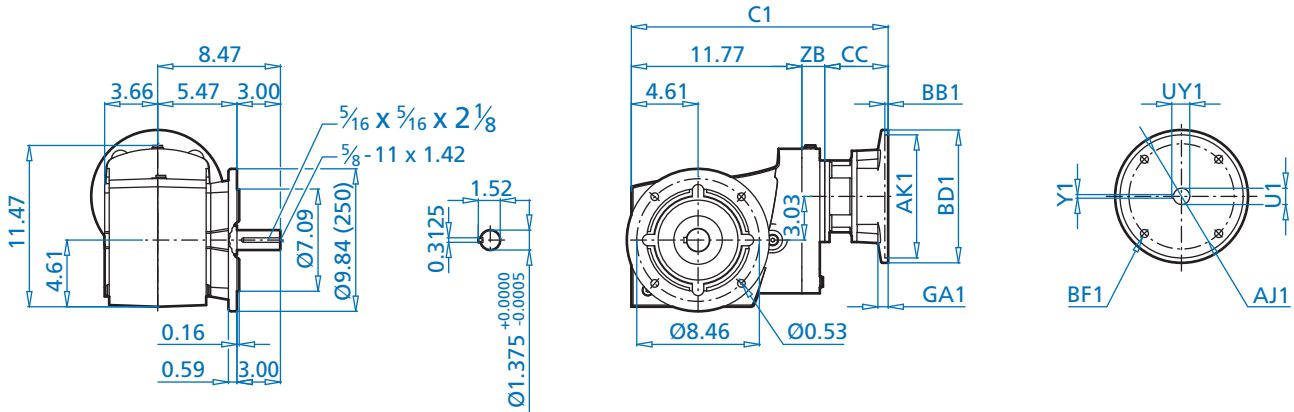

**SK 93772.1AF**

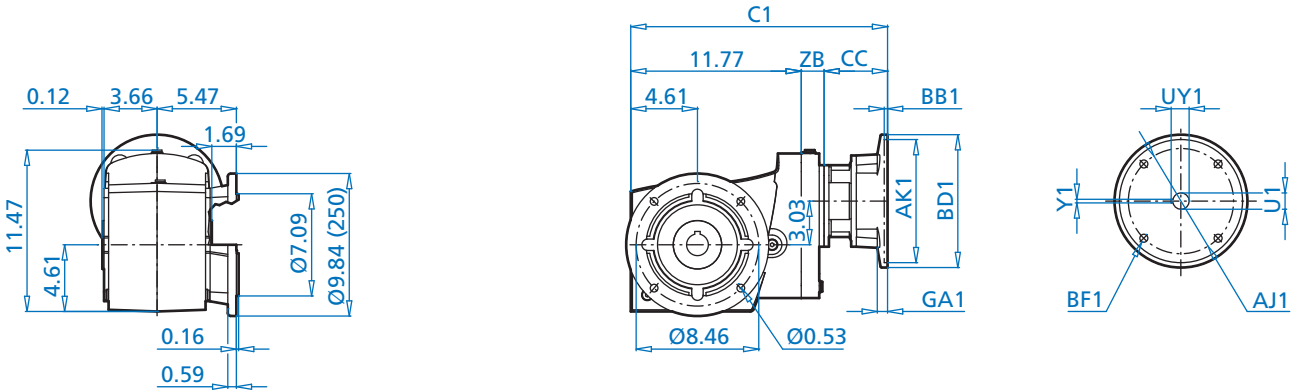

**SK 93772.1AF**

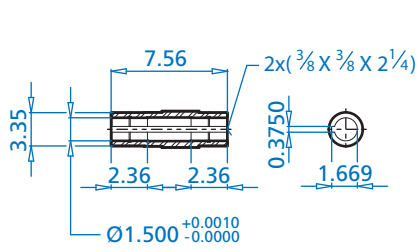

**SK 93772.1AB**

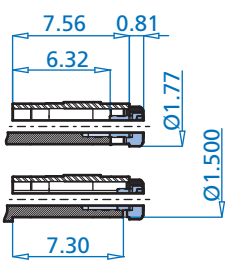

**SK 93772.1AFS**

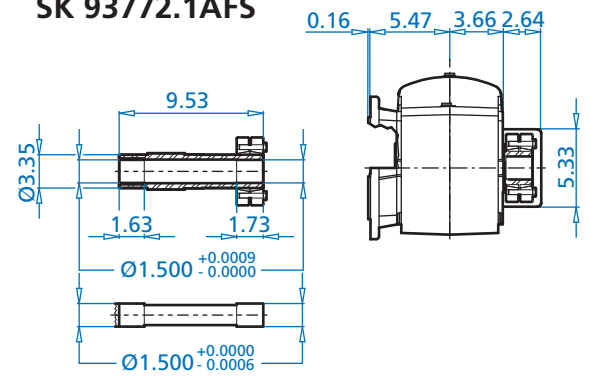

ALTERNATE SHAFTS SEE PAGES 140 - 144

**NEMA Dimensions**

Type	AJ1	AK1	BB1	BD1	BF1	GA1	U1	UY1	Y1	C1	CC	ZB
56C	5,875	4,500	0,18	6,54	0,43	0,47	0,625	0,709	0,188	17,04	3,68	1,59
140TC	5,875	4,500	0,18	6,54	0,43	0,47	0,875	0,964	0,188	17,51	4,15	1,59
180TC	7,250	8,500	0,23	9,17	0,55	0,71	1,125	1,241	0,250	17,74	4,38	1,59
210TC	7,250	8,500	0,23	9,17	0,59	0,98	1,375	1,518	0,312	18,56	4,96	1,82



# Solid Input Shaft Type - W



SK 92072.1W /93072.1W -  
SK 92772.1W /93772.1W

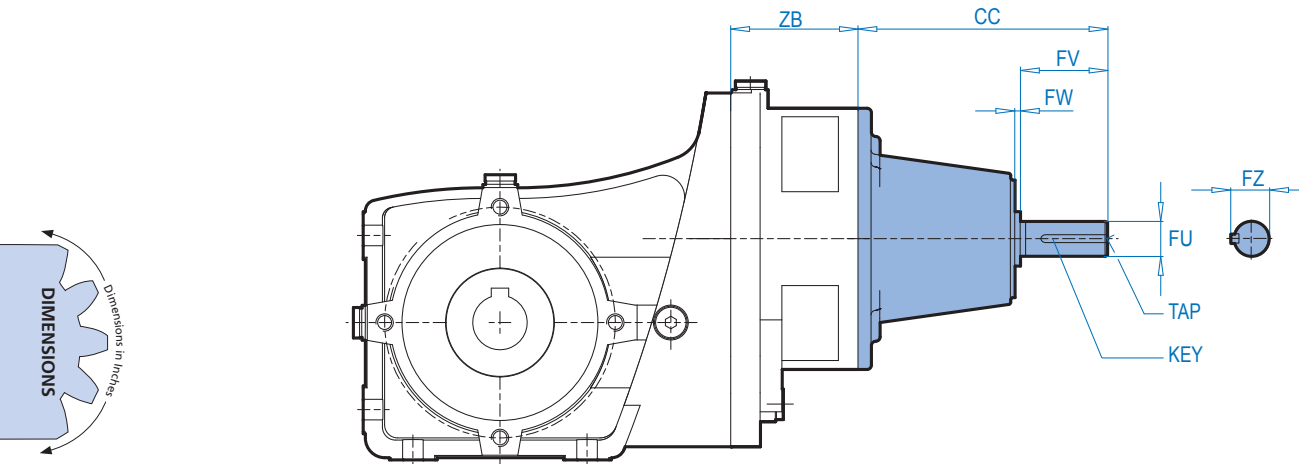

## Inch Units

Unit	ZB	CC	FW	FV	FU	FZ	TAP	KEY	Unit Dimensions
SK 92072.1W	2.68	4.51	0.10	1.57	0.625	0.709	1/4 x 20	3/16 x 3/16 x 1 1/4	⇒ 90
SK 93072.1W					-0.0004				⇒ 110
SK 92172.1W	3.05	4.51	0.10	1.57	0.625	0.709	1/4 x 20	3/16 x 3/16 x 1 1/4	⇒ 94
SK 93172.1W					-0.0004				⇒ 114
SK 92372.1W	1.30	7.01	0.31	2.00	0.875	0.964	1/4 x 20	3/16 x 3/16 x 1 1/2	⇒ 98
SK 93372.1W					-0.0005				⇒ 118
SK 92672.1W	1.37	7.01	0.31	2.00	0.875	0.964	1/4 x 20	3/16 x 3/16 x 1 1/2	⇒ 102
SK 93672.1W					-0.0005				⇒ 122
SK 92772.1W	1.59	7.01	0.31	2.00	0.875	0.964	1/4 x 20	3/16 x 3/16 x 1 1/2	⇒ 106
SK 93772.1W					-0.0005				⇒ 126

## mm Units

Unit	ZB	CC	FW	FV	FU	FZ	TAP	KEY	Unit Dimensions
SK 92072.1W	46	114.5	2.5	40	16	18	M6 x 16	5 x 5 x 32	⇒ 90
SK 93072.1W					+0.001				⇒ 110
SK 92172.1W	44.5	114.5	2.5	40	16	18	M6 x 16	5 x 5 x 32	⇒ 94
SK 93172.1W					+0.001				⇒ 114
SK 92372.1W	33	177.5	8	50	24	27	M8 x 19	8 x 7 x 40	⇒ 98
SK 93372.1W					+0.002				⇒ 118
SK 92672.1W	34.8	177.5	8	50	24	27	M8 x 19	8 x 7 x 40	⇒ 102
SK 93672.1W					+0.002				⇒ 122
SK 92772.1W	N/A	177.5	8	50	24	27	M8 x 19	8 x 7 x 40	⇒ 106
SK 93772.1W					+0.002				⇒ 126



SK 92072.1/93072.1-IEC 56 through SK 92372.1/93372.1-IEC 90  
 SK 92672.1/93672.1-IEC 63 through IEC90  
 SK 92772.1/93772.1-IEC 63 through IEC90

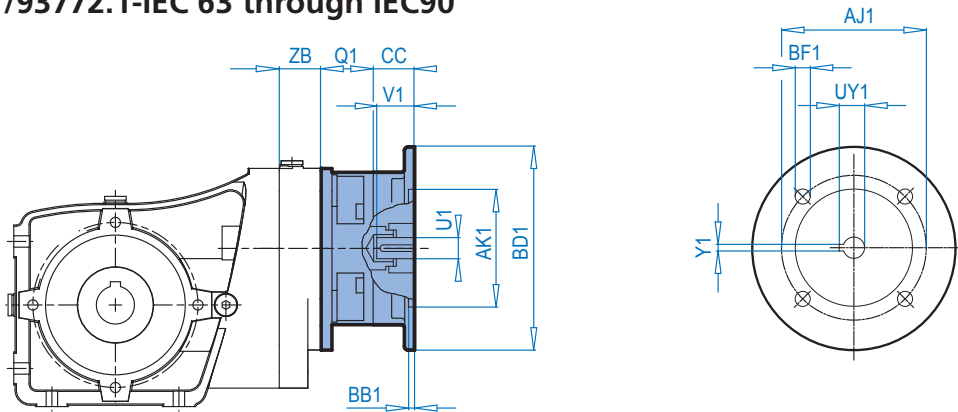

SK 92372.1/93372.1-IEC 100 &  
 SK 92672.1/93672.1-IEC 100 through IEC 132 &  
 SK 92772.1/93772.1-IEC 100 through IEC 132

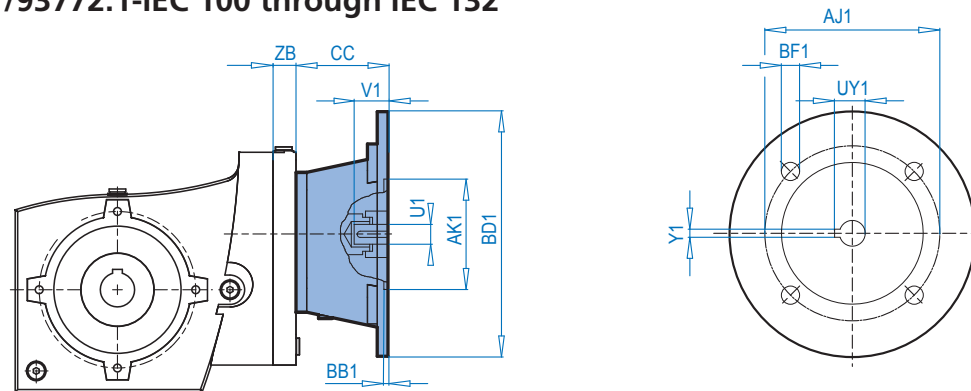

IEC Dimensions (mm)

Input	Flange	CC	AJ1	AK1	BB1	BD1	BF1	U1	V1	UY1	Y1
IEC 56	C105	32.5	85	70	3	105	7	9	20	11.4	3
	A120	32.5	100	80	3.5	120	7				
IEC 63	C90*	32.5	75	60	3	90	6	11	23	12.8	4
	C120	32.5	100	80	3.5	120	7				
	A140	32.5	115	95	3.5	140	9				
IEC 71	C105*	32.5	85	70	3	105	7	14	30	16.3	5
	C140	32.5	115	95	3.5	140	9				
	A160	32.5	130	110	4	160	9				
IEC 80	C120*	32.5	100	80	3.5	120	7	19	40	21.8	6
	C160	32.5	130	110	4	160	9				
	A200	32.5	165	130	4	200	M10x20				
IEC 90	C140*	45.5	115	95	3.5	140	9	24	50	27.3	8
	C160	45.5	130	110	4	160	9				
	A200	45.5	165	130	4	200	M10x20				
IEC 100	A250	82	215	180	5	250	M12x20	28	60	31.3	8
IEC 112	A250	82	215	180	5	250	M12x20	28	60	31.3	8
IEC 132	A300	111	265	300	5	300	M12x20	38	80	41.3	10

\*Preferred Flange Sizes

Unit	Ratio	Q1
SK 92072.1/ SK 93072.1	All	46
SK 92172.1/ SK 93172.1	All	44.5
SK 92372.1/ SK 93372.1	≥ 18.33 < 18.33	56 40
SK 92672.1/ SK 93672.1	≥ 18.21 < 18.21	56 40
SK 92772.1/ SK 93772.1	≥ 28.38 < 28.38	56 40

Unit	IEC	ZB
SK 92072.1/ SK 93072.1	56 - 80	22
SK 92172.1/ SK 93172.1	56 - 90	33
SK 92372.1/ SK 93372.1	63 - 100	33
SK 92672.1/ SK 93672.1	63 - 112 132	34.5 40.5
SK 92772.1/ SK 93772.1	90 - 112 132	40.3 46.3

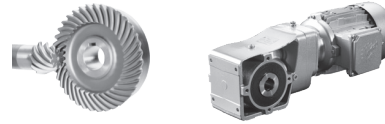

## SK 92072.1 - SK 92772.1

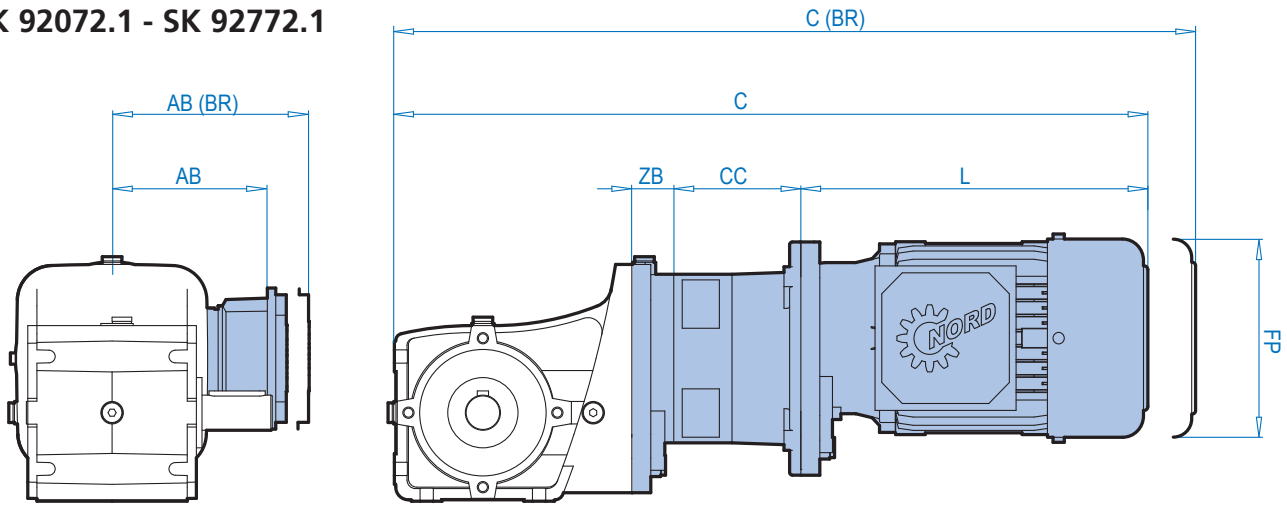

Reducer	Input	Motor	SE	EE	PE	AB	AB (BR)	C	C (BR)	CC	FP	L	L (BR)	ZB
92072.1	56C	63	S/L	-	-	4.51	4.84	17.69	19.90	1.46	5.09	7.57	9.78	2.68
		71	S/L	-	-	4.86	5.24	18.56	20.84	1.46	5.72	8.44	10.72	2.68
		80	S	SH	SP	5.59	5.59	19.58	22.10	1.46	6.43	9.46	11.98	2.68
	140TC	80	-	LH	LP	5.59	5.59	20.06	22.57	1.93	6.43	9.46	11.98	2.68
		90	-	SH/LH	SP/LP	5.79	5.79	21.59	24.54	1.93	7.19	11.00	13.95	2.68
92172.1	56C	63	S/L	-	-	4.51	4.84	18.74	20.94	1.46	5.09	7.57	9.78	3.05
		71	S/L	-	-	4.86	5.24	19.60	21.89	1.46	5.72	8.44	10.72	3.05
		80	S	SH	SP	5.59	5.59	20.63	23.15	1.46	6.43	9.46	11.98	3.05
	140TC	80	-	LH	LP	5.59	5.59	21.10	23.62	1.93	6.43	9.46	11.98	3.05
		90	-	SH/LH	SP/LP	5.79	5.79	22.63	25.59	1.93	7.19	11.00	13.95	3.05
92372.1	56C	63	S/L	-	-	4.51	4.84	20.78	22.99	3.68	5.09	7.57	9.78	1.30
		71	S/L	-	-	4.86	5.24	21.65	23.93	3.68	5.72	8.44	10.72	1.30
		80	S	SH	SP	5.59	5.59	22.67	25.19	3.68	6.43	9.46	11.98	1.30
	140TC	80	-	LH	LP	5.59	5.59	23.15	25.67	4.15	6.43	9.46	11.98	1.30
		90	-	SH/LH	SP/LP	5.79	5.79	24.68	27.63	4.15	7.19	11.00	13.95	1.30
		100	-	LH	LP	6.65	6.77	25.88	29.48	4.38	8.87	11.97	15.57	1.30
180TC	112	-	MH	MP	7.05	7.17	27.46	31.17	4.38	8.87	13.56	17.26	1.30	
	56C	63	S/L	-	-	4.51	4.84	22.82	25.03	3.68	5.09	7.57	9.78	1.37
		71	S/L	-	-	4.86	5.24	23.69	25.97	3.68	5.72	8.44	10.72	1.37
80		S	SH	SP	5.59	5.59	24.71	27.23	3.68	6.43	9.46	11.98	1.37	
140TC	80	-	LH	LP	5.59	5.59	25.19	27.70	4.15	6.43	9.46	11.98	1.37	
	90	-	SH/LH	SP/LP	5.79	5.79	26.72	29.67	4.15	7.19	11.00	13.95	1.37	
	100	-	LH	LP	6.65	6.77	27.92	31.52	4.38	8.87	11.97	15.57	1.37	
180TC	112	-	MH	MP	7.05	7.17	29.50	33.20	4.38	8.87	13.56	17.26	1.37	
	210TC	132	-	SH/MH	SP/MP	8.03	7.91	33.24	37.45	4.96	10.45	16.47	20.69	1.61
92772.1	56C	63	S/L	-	-	4.51	4.84	24.42	26.62	3.68	5.09	7.57	9.78	1.59
		71	S/L	-	-	4.86	5.24	25.28	27.57	3.68	5.72	8.44	10.72	1.59
		80	S	SH	SP	5.59	5.59	26.31	28.83	3.68	6.43	9.46	11.98	1.59
	140TC	80	-	LH	LP	5.59	5.59	26.78	29.30	4.15	6.43	9.46	11.98	1.59
		90	-	SH/LH	SP/LP	5.79	5.79	28.31	31.27	4.15	7.19	11.00	13.95	1.59
	180TC	100	-	LH	LP	6.65	6.77	29.51	33.11	4.38	8.87	11.97	15.57	1.59
		112	-	MH	MP	7.05	7.17	31.10	34.80	4.38	8.87	13.56	17.26	1.59
		210TC	132	-	SH/MH	SP/MP	8.03	7.91	34.83	39.04	4.96	10.45	16.47	20.69



## SK 93072.1 - SK 93772.1

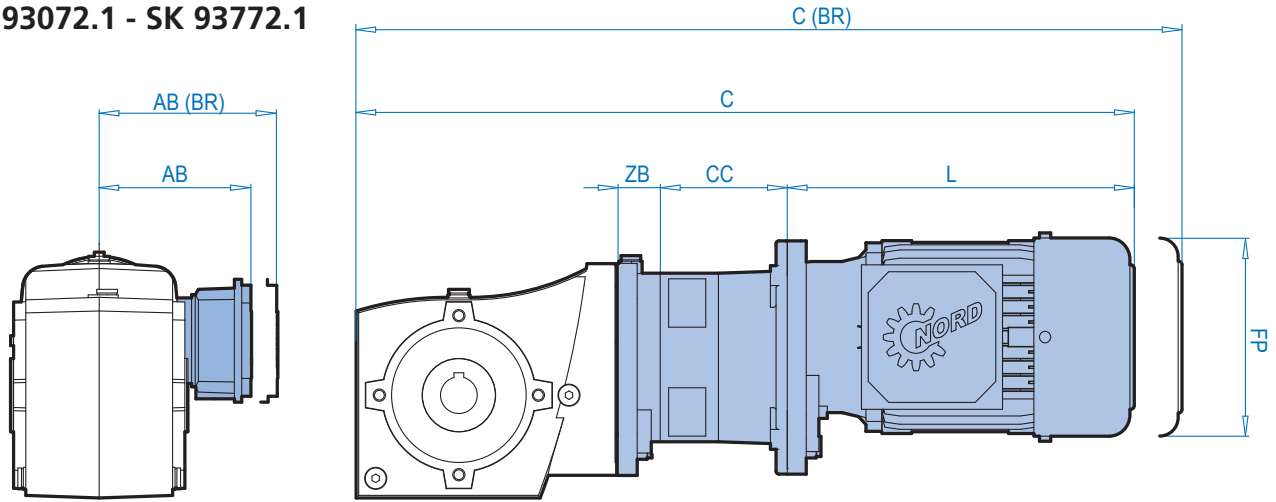

Reducer	Input	Motor	SE	EE	PE	AB	AB (BR)	C	C (BR)	CC	FP	L	L (BR)	ZB
93072.1	56C	63	S/L	-	-	4.51	4.84	17.81	20.01	1.46	5.09	7.57	9.78	2.68
		71	S/L	-	-	4.86	5.24	18.67	20.96	1.46	5.72	8.44	10.72	2.68
		80	S	SH	SP	5.59	5.59	19.70	22.22	1.46	6.43	9.46	11.98	2.68
	140TC	80	-	LH	LP	5.59	5.59	19.70	22.22	1.46	6.43	9.46	11.98	2.68
		90	-	SH/LH	SP/LP	5.79	5.79	21.23	24.18	1.46	7.19	11.00	13.95	2.68
93172.1	56C	63	S/L	-	-	4.51	4.84	18.81	21.02	1.46	5.09	7.57	9.78	3.05
		71	S/L	-	-	4.86	5.24	19.68	21.96	1.46	5.72	8.44	10.72	3.05
		80	S	SH	SP	5.59	5.59	20.70	23.22	1.46	6.43	9.46	11.98	3.05
	140TC	80	-	LH	LP	5.59	5.59	21.18	23.70	1.93	6.43	9.46	11.98	3.05
		90	-	SH/LH	SP/LP	5.79	5.79	22.71	25.67	1.93	7.19	11.00	13.95	3.05
93372.1	56C	63	S/L	-	-	4.51	4.84	20.94	23.15	3.68	5.09	7.57	9.78	1.30
		71	S/L	-	-	4.86	5.24	21.81	24.09	3.68	5.72	8.44	10.72	1.30
		80	S	SH	SP	5.59	5.59	22.83	25.35	3.68	6.43	9.46	11.98	1.30
	140TC	80	-	LH	LP	5.59	5.59	23.30	25.82	4.15	6.43	9.46	11.98	1.30
		90	-	SH/LH	SP/LP	5.79	5.79	24.84	27.79	4.15	7.19	11.00	13.95	1.30
	180TC	100	-	LH	LP	6.65	6.77	26.04	29.64	4.38	8.87	11.97	15.57	1.30
112		-	MH	MP	7.05	7.17	27.62	31.32	4.38	8.87	13.56	17.26	1.30	
93672.1	56C	63	S/L	-	-	4.51	4.84	23.00	25.20	3.68	5.09	7.57	9.78	1.37
		71	S/L	-	-	4.86	5.24	23.87	26.15	3.68	5.72	8.44	10.72	1.37
		80	S	SH	SP	5.59	5.59	24.89	27.41	3.68	6.43	9.46	11.98	1.37
	140TC	80	-	LH	LP	5.59	5.59	25.36	27.88	4.15	6.43	9.46	11.98	1.37
		90	-	SH/LH	SP/LP	5.79	5.79	26.90	29.85	4.15	7.19	11.00	13.95	1.37
	180TC	100	-	LH	LP	6.65	6.77	28.09	31.70	4.38	8.87	11.97	15.57	1.37
		112	-	MH	MP	7.05	7.17	29.68	33.38	4.38	8.87	13.56	17.26	1.37
210TC	132	-	SH/MH	SP/MP	8.03	7.91	33.41	37.63	4.96	10.45	16.47	20.69	1.61	
93772.1	56C	63	S/L	-	-	4.51	4.84	24.64	26.85	3.68	5.09	7.57	9.78	1.59
		71	S/L	-	-	4.86	5.24	25.51	27.79	3.68	5.72	8.44	10.72	1.59
		80	S	SH	SP	5.59	5.59	26.53	29.05	3.68	6.43	9.46	11.98	1.59
	140TC	80	-	LH	LP	5.59	5.59	27.01	29.53	4.15	6.43	9.46	11.98	1.59
		90	-	SH/LH	SP/LP	5.79	5.79	28.54	31.49	4.15	7.19	11.00	13.95	1.59
	180TC	100	-	LH	LP	6.65	6.77	29.74	33.34	4.38	8.87	11.97	15.57	1.59
		112	-	MH	MP	7.05	7.17	31.33	35.03	4.38	8.87	13.56	17.26	1.59
	210TC	132	-	SH/MH	SP/MP	8.03	7.91	35.06	39.27	4.96	10.45	16.47	20.69	1.82



## SK 92072.1 - SK 92772.1

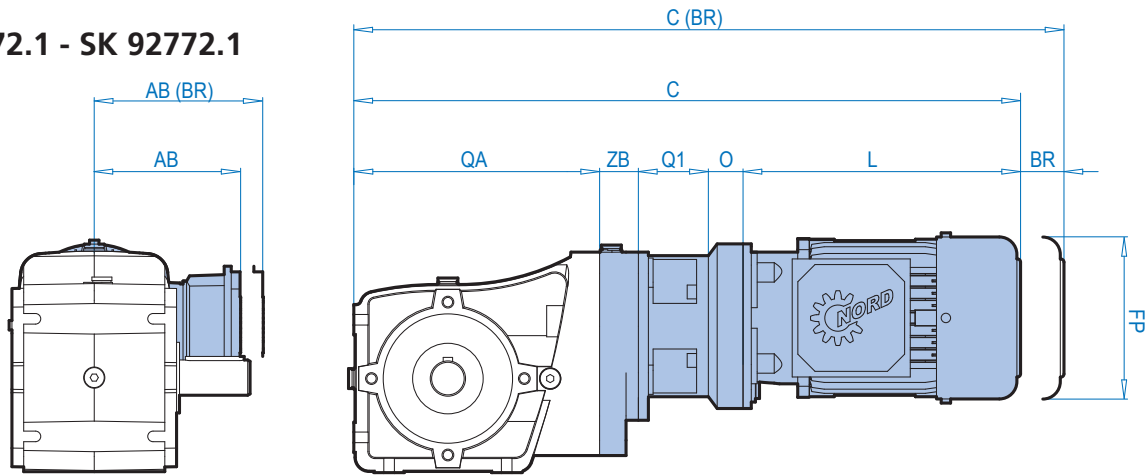

DIMENSIONS

		Ratio	AB	AB (BR)	QA	ZB	Q1	O	L	BR	FP	C	C (BR)
92072.1	IEC 63	All	114.5	123	152	22	46	32.5	192	56	129	445	501
	IEC 71	All	123.5	133	152	22	46	32.5	214	58	145	467	525
	IEC 80	All	142	142	152	22	46	32.5	236	64	163	489	553
92172.1	IEC 63	All	114.5	123	169	33	44.5	32.5	192	56	129	471	527
	IEC 71	All	123.5	133	169	33	44.5	32.5	214	58	145	493	551
	IEC 80	All	142	142	169	33	44.5	32.5	236	64	163	515	579
	IEC 90	All	147	147	169	33	44.5	45.5	276	75	183	567	642
92372.1	IEC63	< 18.33	114.5	123	209	33	40.5	32.5	192	56	129	507	563
		≥ 18.33					56.5					523	579
	IEC71	< 18.33	123.5	133	209	33	40.5	32.5	214	58	145	529	587
		≥ 18.33					56.5					545	603
	IEC 80	< 18.33	142	142	209	33	40.5	32.5	236	64	163	551	615
		≥ 18.33					56.5					567	631
	IEC 90	< 18.33	147	147	209	33	40.5	45.5	275	75	183	603	678
		≥ 18.33					56.5					619	694
	IEC 100	< 18.33	169	172	209	33	40.5	82.0	306	91.5	225	671	762
		≥ 18.33					56.5					687	778
	IEC 112	< 18.33	179	182	259	35	40.5	82.0	326	94	225	715	809
		≥ 18.33					56.5					731	825
92672.1	IEC 63	< 18.21	114.5	123	259	34.5	40.5	32.5	192	56	129	559	615
		≥ 18.21					56.5					575	631
	IEC 71	< 18.21	123.5	133	259	34.5	40.5	32.5	214	58	145	581	639
		≥ 18.21					56.5					597	655
	IEC 80	< 18.21	142	142	259	34.5	40.5	32.5	236	64	163	603	667
		≥ 18.21					56.5					619	683
	IEC 90	< 18.21	147	147	259	34.5	40.5	45.5	275	75	183	655	730
		≥ 18.21					56.5					671	746
	IEC 100	< 18.21	169	172	259	34.5	40.5	82.0	306	91.5	225	722	814
		≥ 18.21					56.5					738	830
	IEC 112	< 18.21	179	182	259	34.5	40.5	82.0	351	94	225	767	861
		≥ 18.21					56.5					783	877
IEC 132	< 18.21	204	201	259	40.5	40.5	111	435	107	265	886	993	
	≥ 18.21					56.5					902	1009	
92772.1	IEC 63	< 28.38	114.5	123	294	40.3	40.5	32.5	192	56	129	600	656
		≥ 28.38					56.5					616	672
	IEC 71	< 28.38	123.5	133	294	40.3	40.5	32.5	214	58	145	622	680
		≥ 28.38					56.5					638	696
	IEC 80	< 28.38	142	142	294	40.3	40.5	32.5	236	64	163	644	708
		≥ 28.38					56.5					660	724
	IEC 90	< 28.38	147	147	294	40.3	40.5	45.5	275	75	183	696	771
		≥ 28.38					56.5					712	787
	IEC 100	< 28.38	169	172	294	40.3	40.5	82.0	306	91.5	225	763	855
		≥ 28.38					56.5					779	871
	IEC 112	< 28.38	179	182	294	40.3	40.5	82.0	351	94	225	808	902
		≥ 28.38					56.5					824	918
IEC 132	< 28.38	204	201	294	46.3	40.5	111	435	107	265	927	1034	
	≥ 28.38					56.5					943	1050	



## SK 93072.1 - SK 93772.1

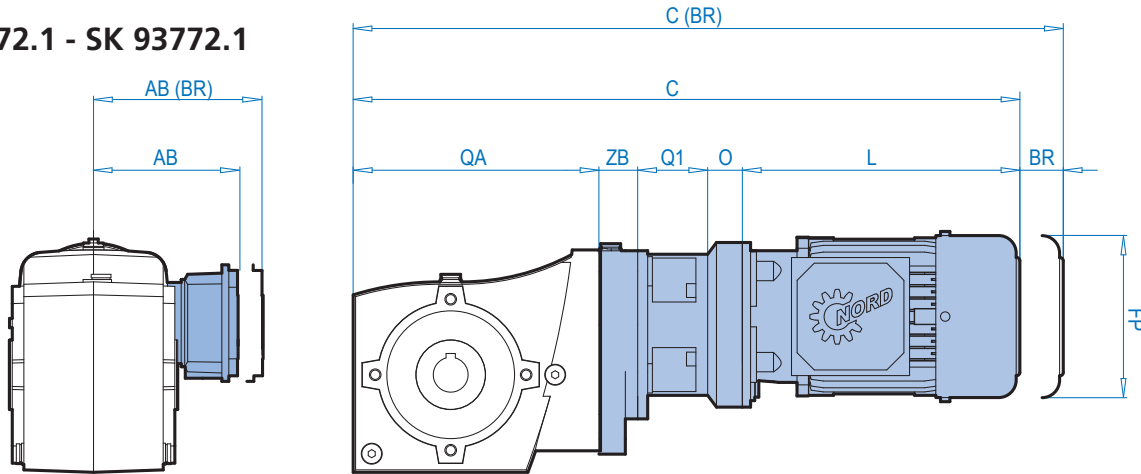

		Ratio	AB	AB (BR)	QA	ZB	Q1	O	L	BR	FP	C	C (BR)
93072.1	IEC 63	All	114.5	123	154.9	22	46	32.5	192	56	129	448	504
	IEC 71	All	123.5	133	154.9	22	46	32.5	214	58	145	470	528
	IEC 80	All	142	142	154.9	22	46	32.5	236	64	163	492	556
93172.1	IEC 63	All	114.5	123	171	33	44.5	32.5	192	56	129	473	529
	IEC 71	All	123.5	133	171	33	44.5	32.5	214	58	145	495	553
	IEC 80	All	142	142	171	33	44.5	32.5	236	64	163	517	581
	IEC 90	All	147	147	171	33	44.5	45.5	276	75	183	569	644
93372.1	IEC63	< 18.33	114.5	123	213	33	40.5	32.5	192	56	129	511	567
		≥ 18.33					56.5					527	583
	IEC71	< 18.33	123.5	133	213	33	40.5	32.5	214	58	145	533	591
		≥ 18.33					56.5					549	607
	IEC 80	< 18.33	142	142	213	33	40.5	32.5	236	64	163	555	619
		≥ 18.33					56.5					571	635
IEC 90	< 18.33	147	147	213	33	40.5	45.5	275	75	183	607	682	
	≥ 18.33					56.5					623	698	
IEC 100	< 18.33	169	172	213	33	40.5	82.0	306	91.5	225	675	766	
	≥ 18.33					56.5					691	782	
IEC 112	< 18.33	179	182	213	35	40.5	82.0	326	94	225	719	813	
	≥ 18.33					56.5					735	829	
93672.1	IEC 63	< 18.21	114.5	123	263.5	34.5	40.5	32.5	192	56	129	563	619
		≥ 18.21					56.5					579	635
	IEC 71	< 18.21	123.5	133	263.5	34.5	40.5	32.5	214	58	145	585	643
		≥ 18.21					56.5					601	659
	IEC 80	< 18.21	142	142	263.5	34.5	40.5	32.5	236	64	163	607	671
		≥ 18.21					56.5					623	687
	IEC 90	< 18.21	147	147	263.5	34.5	40.5	45.5	275	75	183	659	734
≥ 18.21		56.5					675					750	
IEC 100	< 18.21	169	172	263.5	34.5	40.5	82.0	306	91.5	225	727	818	
	≥ 18.21					56.5					743	834	
IEC 112	< 18.21	179	182	263.5	34.5	40.5	82.0	351	94	225	771	865	
	≥ 18.21					56.5					787	881	
IEC 132	< 18.21	204	201	263.5	40.5	40.5	111	435	107	265	891	998	
	≥ 18.21					56.5					907	1014	
93772.1	IEC 63	< 28.38	114.5	123	299	40.3	40.5	32.5	192	56	129	606	662
		≥ 28.38					56.5					622	678
	IEC 71	< 28.38	123.5	133	299	40.3	40.5	32.5	214	58	145	628	686
		≥ 28.38					56.5					644	702
	IEC 80	< 28.38	142	142	299	40.3	40.5	32.5	236	64	163	650	714
		≥ 28.38					56.5					666	730
	IEC 90	< 28.38	147	147	299	40.3	40.5	45.5	275	75	183	702	777
		≥ 28.38					56.5					718	793
IEC 100	< 28.38	169	172	299	40.3	40.5	82.0	306	91.5	225	769	861	
	≥ 28.38					56.5					785	877	
IEC 112	< 28.38	179	182	299	40.3	40.5	82.0	351	94	225	813	907	
	≥ 28.38					56.5					829	923	
IEC 132	< 28.38	204	201	299	46.3	40.5	111	435	107	265	933	1040	
	≥ 28.38					56.5					949	1056	





# B14 Flange Design



SK 92072.1/93072.1 -  
SK 92772.1/93772.1

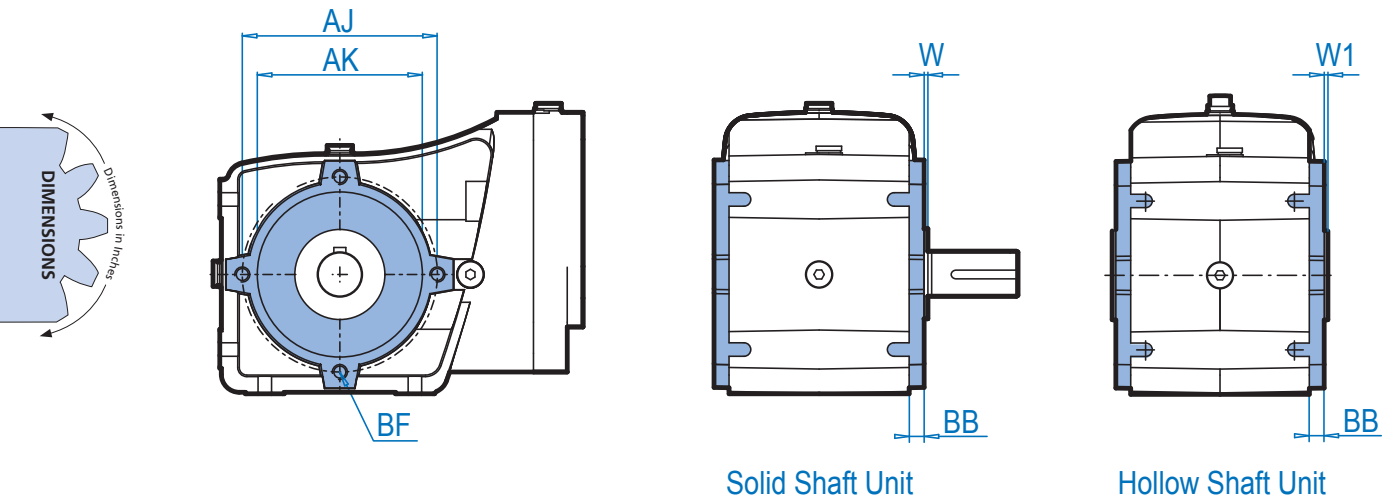

ALTERNATE SHAFTS SEE PAGES 140 - 144

Type	AK	AJ	BB	BF (mm)	W	W1
SK 92072.1/93072.1	3.15	3.74	0.18	M8 x 18	0.10	0.10
SK 92172.1/93172.1	3.54	4.17	0.26	M8 x 18	0.10	0.10
SK 92372.1/93372.1	4.33	5.12	0.39	M10 x 20	0.10	0.10
SK 92672.1/93672.1	5.12	6.30	0.33	M10 x 20	0.16	0.16
SK 92772.1/93772.1	5.91	6.89	0.20	M12 x 20	0.16	0.16



## SK 92072.1/93072.1 D - SK 92772.1/93772.1 D

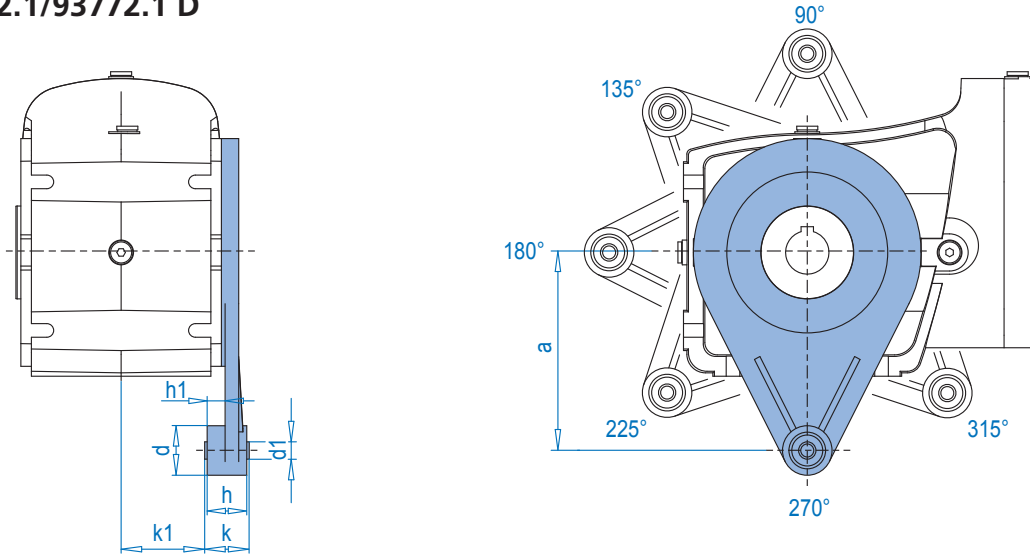

Type	a	d	d1	h	h1	k	k1
SK 92072.1/93072.1 D	4.33	1.57	0.41	1.26	0.47	1.44	1.73
SK 92172.1/93172.1 D	4.72	1.57	0.41	1.26	0.47	1.44	1.81
SK 92372.1/93372.1 D	6.30	1.57	0.41	1.26	0.45	1.42	2.22
SK 92672.1/93672.1 D	6.30	1.57	0.41	1.26	0.45	1.42	2.66
SK 92772.1/93772.1 D	7.87	2.36	0.65	2.20	1.14	2.36	2.44

## SK 92072.1/93072.1H - SK 92772.1/93772.1H

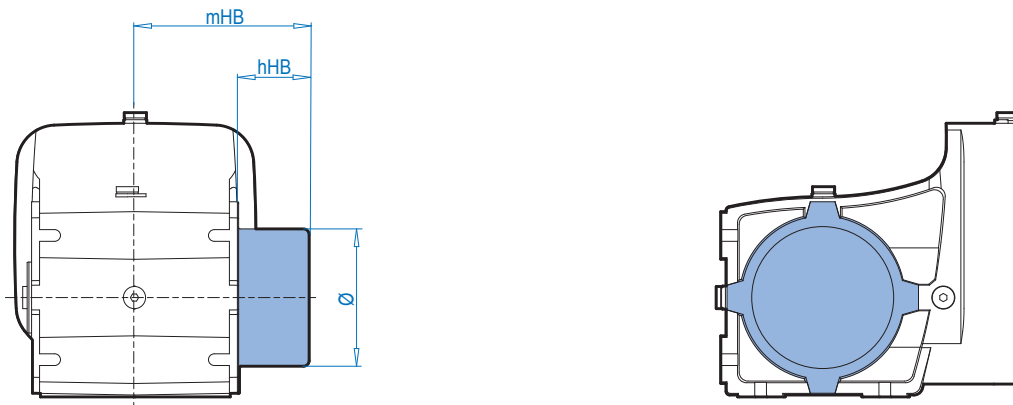

Type	hHB	mHB	Ø
SK 92072.1/93072.1 H	1.57	3.85	2.83
SK 92172.1/93172.1 H	2.01	4.33	3.38
SK 92372.1/93372.1 H	2.52	5.28	3.89
SK 92672.1/93672.1 H	2.52	5.71	5.03
SK 92772.1/93772.1 H	2.64	6.30	5.33

# 93.1 Series Tapped Hole Option



93072.1 - 93772.1

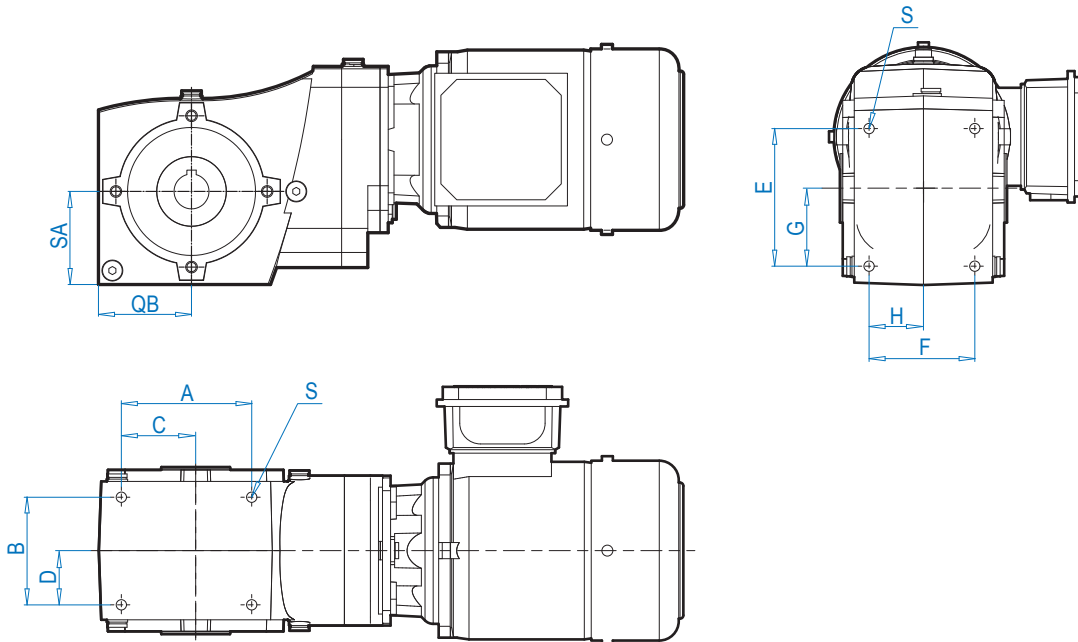

Type	A	B	C	D	E	F	G	H	SA	QB	S
SK 93072.1	2.76	3.54	1.38	1.77	2.76	3.54	1.38	1.77	2.20	2.20	M6 x 0.39
SK 93172.1	3.15	3.54	1.57	1.77	3.15	3.54	1.57	1.77	2.48	2.48	M8 x 0.63
SK 93372.1	3.94	3.94	1.97	1.97	3.94	3.94	1.97	1.97	3.15	3.15	M8 x 0.63
SK 93672.1	4.72	4.72	2.36	2.36	4.72	4.72	2.36	2.36	3.94	3.94	M10 x 0.59
SK 93772.1	5.51	5.51	2.76	2.76	5.51	5.51	2.76	2.76	4.41	4.41	M12 x 0.59



SK 92172.1-92672.1  
SK 93172.1-93672.1  
Type-1 - Threaded Holes

SK 92172.1-92672.1  
SK 93172.1-93672.1  
Type-2 - Extended with Thru Holes

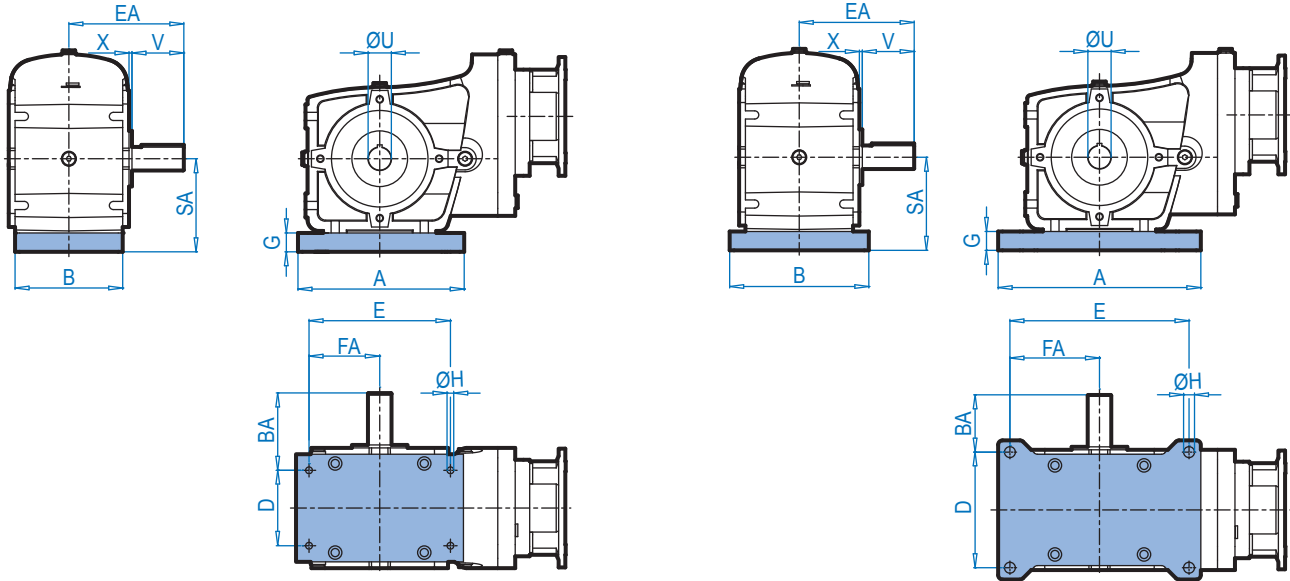

### Type 1 Dimensions

Worm Size [in]	NORD Model Type	Footplate Dimensions									Shaft Dimensions				92.1 Series Kit No.	93.1 Series Kit No.
		E	D	FA	ØH	X	SA	A	B	G	ØU	V	EA	BA		
2.3*	SK9x172.1	5.00	2.875	2.50	3/8-16 x 0.69	0.10	3.48	7.26	4.72	1.00	1.125	2.68	5.14	3.70	162194600	162194610
2.3*	SK9x372.1	5.00	2.875	2.50	3/8-16 x 0.69	0.10	4.15	7.26	4.72	1.00	1.125	2.29	5.14	3.70	162194600	162194610
2.6	SK9x372.1	6.38	3.375	3.19	3/8-16 x 0.69	0.10	4.15	7.26	4.72	1.00	1.125	2.78	5.63	3.94	162194600	162194610
3.0	SK9x372.1	7.00	4.00	3.50	7/16-14 x 0.88	0.10	4.15	8.24	5.71	1.00	1.375	3.90	6.75	4.75	162394600	162394610
3.0	SK9x672.1	7.00	4.00	3.50	7/16-14 x 0.88	0.16	4.94	8.24	5.71	1.00	1.375	3.40	6.75	4.75	162694600	162694610
3.5	SK9x672.1	7.50	4.00	3.75	7/16-14 x 0.81	0.16	4.94	8.88	5.71	1.00	1.500	3.71	7.06	5.06	162694620	162694630

\* Both Foot Kits for worm size 2.3 have a slightly larger profile than the industry standard. (See A & B dimensions)

### Type 2 Dimensions

Worm Size [in]	NORD Model Type	Footplate Dimensions									Shaft Dimensions				92.1 Series Kit No.	93.1 Series Kit No.
		E	D	FA	ØH	X	SA	A	B	G	ØU	V	EA	BA		
2.3*	SK9x172.1	7.06	4.875	3.53	0.47	0.10	3.48	9.25	6.50	1.00	1.125	2.68	5.14	2.70	162194700	162194710
2.3*	SK9x372.1	7.06	4.875	3.53	0.47	0.10	4.15	9.25	6.50	1.00	1.125	2.29	5.14	2.70	162194700	162194710
2.6	SK9x372.1	8.00	5.25	4.00	0.53	0.10	4.15	9.25	6.50	1.00	1.125	2.78	5.63	3.00	162194700	162194710
3.0	SK9x372.1	8.44	5.875	4.22	0.53	0.10	4.15	9.68	7.12	1.00	1.375	3.90	6.75	3.81	162394700	162394710
3.0	SK9x672.1	8.44	5.875	4.22	0.53	0.16	4.94	9.68	7.12	1.00	1.375	3.40	6.75	3.81	162694700	162694710
3.5	SK9x672.1	9.50	6.125	4.75	0.58	0.16	4.94	10.75	7.38	1.00	1.500	3.71	7.06	4.00	162694720	162694730

\* Both Foot Kits for worm size 2.3 have a slightly larger profile than the industry standard. (See A & B dimensions)

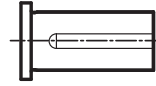

## Solid Shaft Dimensions (V & VF)

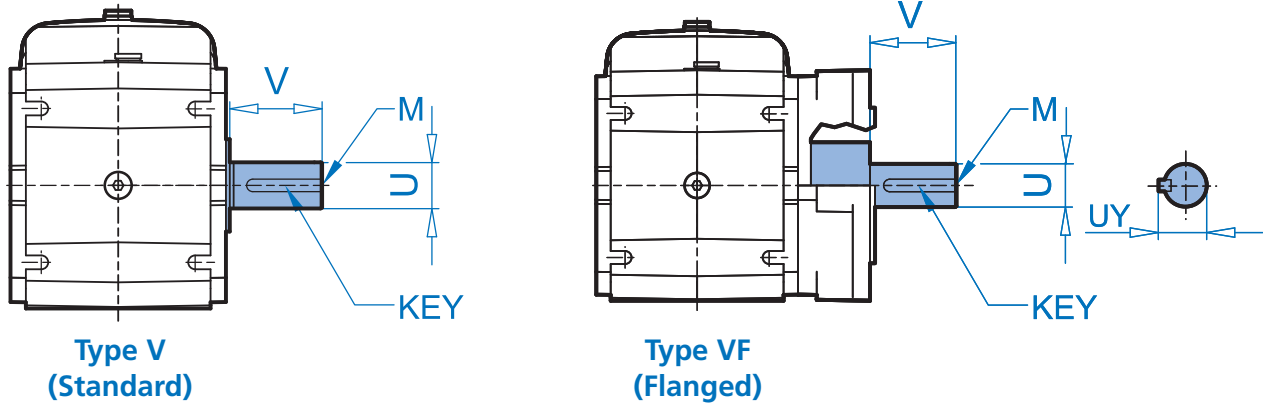

ALTERNATE SHAFTS SEE PAGES 140 - 144

Unit	U	Diameter Tolerance	V	UY	KEY SIZE	KEY QTY	DRILL & TAP M
SK 92072.1V/VF & SK 93072.1V/VF	0.750	+0.0000 / -0.0005	1.50	0.83	3/16 x 3/16 x 1-1/4	1	1/4-20
	20 mm	+0.015 / +0.002 mm	40 mm	22.5 mm	6 x 6 x 32	1	M6
	25 mm	+0.015 / +0.002 mm	50 mm	28 mm	8 x 7 x 40 mm	1	M10
SK 92172.1V/VF & SK 93172.1V/VF	0.750	+0.0000 / -0.0005	1.50	0.83	3/16 x 3/16 x 1-1/4	1	1/4-20
	20 mm	+0.015 / +0.002 mm	40 mm	22.5 mm	6 x 6 x 32 mm	1	M6
	25 mm	+0.015 / +0.002 mm	50 mm	28 mm	8 x 7 x 40 mm	1	M10
SK 92372.1V/VF & SK 93372.1V/VF	1.000*	+0.0000 / -0.0005	2.13	1.11	1/4 x 1/4 x 1-5/8	1	3/8-16
	1.250	+0.0000 / -0.0005	2.75	1.37	1/4 x 1/4 x 2-1/4	1	1/2-13
	25 mm	+0.015 / +0.002 mm	50 mm	28 mm	8 x 7 x 40 mm	1	M10
	30 mm	+0.015 / +0.002 mm	60 mm	33 mm	8 x 7 x 50 mm	1	M10
SK 92672.1V/VF & SK 93672.1V/VF	1.250	+0.0000 / -0.0005	2.75	1.36	1/4 x 1/4 x 2-1/4	1	1/2-13
	30 mm	+0.015 / +0.002 mm	60 mm	33 mm	8 x 7 x 50 mm	1	M10
	35 mm	+0.018 / +0.002 mm	70 mm	38 mm	10 x 8 x 56 mm	1	M12
SK 92772.1V/VF & SK 93772.1V/VF	1.375	+0.0000 / -0.0005	3.00	1.51	5/16 x 5/16 x 2-1/2	1	5/8-11
	35 mm	+0.018 / +0.002 mm	70 mm	38 mm	10 x 8 x 60 mm	1	M12
	40 mm	+0.018 / +0.002 mm	80 mm	43 mm	12 x 8 x 70 mm	1	M16

\* standard size

- Dimensions are in inches unless otherwise noted.
- Metric Keys are captured in keyways.
- For shaft sizes not shown, consult NORD.

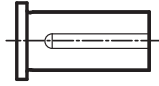

## Double Solid Shaft Dimensions (L)

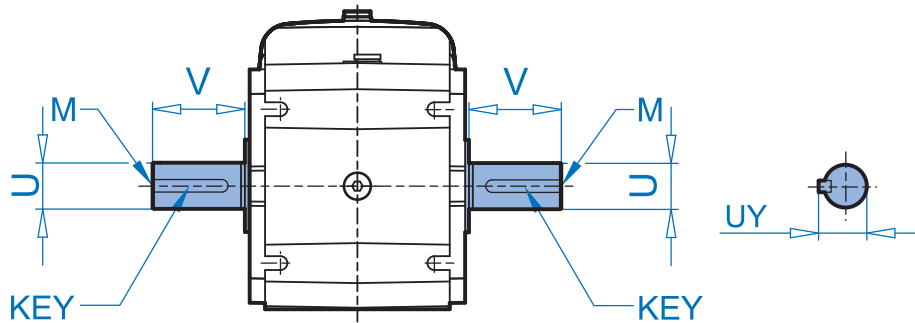

Unit	U	Diameter Tolerance	V	UY	KEY SIZE	KEY QTY	DRILL & TAP M
SK 92072.1L / SK 93072.1L	0.750	+0.0000 / -0.0005	1.50	0.83	3/16 x 3/16 x 1-1/4	2	1/4-20
	20 mm	+0.015 / +0.002 mm	40 mm	22.5 mm	6 x 6 x 32	2	M6
	25 mm	+0.015 / +0.002 mm	50 mm	28 mm	8 x 7 x 40 mm	2	M10
SK 92172.1L / SK 93172.1L	0.750	+0.0000 / -0.0005	1.50	0.83	3/16 x 3/16 x 1-1/4	2	1/4-20
	20 mm	+0.015 / +0.002 mm	40 mm	22.5 mm	6 x 6 x 32 mm	2	M6
	25 mm	+0.015 / +0.002 mm	50 mm	28 mm	8 x 7 x 40 mm	2	M10
SK 92372.1L / SK 93372.1L	1.000*	+0.0000 / -0.0005	2.13	1.11	1/4 x 1/4 x 1-5/8	2	3/8-16
	1.250	+0.0000 / -0.0005	2.75	1.37	1/4 x 1/4 x 2-1/4	2	1/2-13
	25 mm	+0.015 / +0.002 mm	50 mm	28 mm	8 x 7 x 40 mm	2	M10
	30 mm	+0.015 / +0.002 mm	60 mm	33 mm	8 x 7 x 50 mm	2	M10
SK 92672.1L / SK 93672.1L	1.250	+0.0000 / -0.0005	2.75	1.36	1/4 x 1/4 x 2-1/4	2	1/2-13
	30 mm	+0.015 / +0.002 mm	60 mm	33 mm	8 x 7 x 50 mm	2	M10
	35 mm	+0.018 / +0.002 mm	70 mm	38 mm	10 x 8 x 56 mm	2	M12
SK 92772.1L / SK 93772.1L	1.375	+0.0000 / -0.0005	3.00	1.51	5/16 x 5/16 x 2-1/2	2	5/8-11
	35 mm	+0.018 / +0.002 mm	70 mm	38 mm	10 x 8 x 60 mm	1	M12
	40 mm	+0.018 / +0.002 mm	80 mm	43 mm	12 x 8 x 70 mm	1	M16

- Dimensions are in inches unless otherwise noted.
- Metric Keys are captured in keyways.
- For shaft sizes not shown, consult NORD.



# Hollow Shaft Dimensions

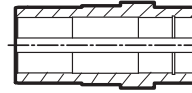

## Hollow Shaft Dimensions (A)

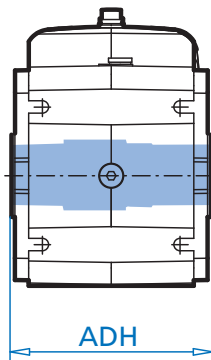

STANDARD

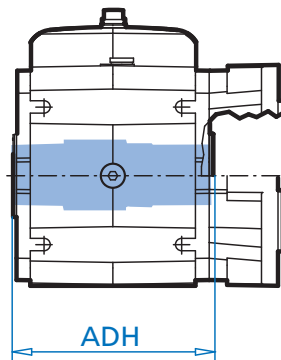

FLANGED

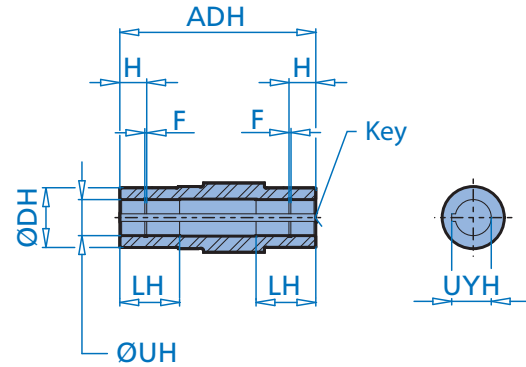

Type	UH	Diameter Tolerance	ADH	LH	DH	H	F	UYH	Key Size w x h x l	Key Qty
SK 92072.1A / SK 93072.1A	0.750*	+0.0010 / -0.0000	4.76	0.98	1.57	0.224	0.043	0.837	3/16 x 3/16 x 1-1/4	2
	0.500	+0.0010 / -0.0000	4.76	0.98	1.57	0.256	0.043	0.560	1/8 x 1/8 x 1-1/4	2
	20mm	+0.021 / +0.000 mm	121 mm	30 mm	40 mm	6.6 mm	1.6 mm	22.8 mm	6 x 6 x 30 mm	2
	25 mm	+0.021 / -0.000 mm	121 mm	30 mm	40 mm	6.6 mm	1.6 mm	28.3 mm	8 x 7 x 30 mm	2
SK 92172.1A / SK 93172.1A	1.000*	+0.0010 / -0.0000	4.92	1.18	1.97	0.472	0.063	1.08	1/4 x 3/16 x 1-1/4	2
	0.750	+0.0010 / -0.0000	4.92	1.18	1.97	0.472	0.043	0.837	3/16 x 3/16 x 1-1/4	2
	20 mm	+0.021 / -0.000 mm	125 mm	30 mm	50 mm	6.6 mm	1.6 mm	22.8 mm	6 x 6 x 30 mm	2
	25 mm	+0.021 / -0.000 mm	125 mm	30 mm	50 mm	6.6 mm	1.6 mm	28.3 mm	8 x 7 x 30 mm	2
SK 92372.1A / SK 93372.1A	30 mm	+0.021 / -0.000 mm	125 mm	30 mm	50 mm	6.6 mm	1.6 mm	33.3 mm	8 x 7 x 30 mm	2
	1.1875*	+0.0010 / -0.0000	5.71	1.77	2.36	0.886	0.063	1.304	1/4 x 1/4 x 2	2
	1.250	+0.0010 / -0.0000	5.71	1.77	2.36	0.896	0.073	1.367	1/4 x 1/4 x 2	2
	1.4375	+0.0010 / -0.0000	5.71	1.77	2.36	0.886	0.073	1.605	3/8 x 3/8 x 2	2
	1.5000	+0.0010 / -0.0000	5.71	1.77	2.36	0.896	0.073	1.669	3/8 x 3/8 x 2	2
	25 mm	+0.021 / -0.000 mm	145 mm	45 mm	60 mm	9.6 mm	1.6 mm	22.8 mm	8 x 7 x 50 mm	2
SK 92672.1A / SK 93672.1A	30 mm	+0.021 / -0.000 mm	145 mm	45 mm	60 mm	9.6 mm	1.6 mm	33.3 mm	8 x 7 x 50 mm	2
	35 mm	+0.025 / -0.000 mm	145 mm	45 mm	60 mm	9.6 mm	1.6 mm	38.3 mm	10 x 8 x 50 mm	2
	40 mm	+0.025 / -0.000 mm	145 mm	45 mm	60 mm	9.6 mm	1.6 mm	43.3 mm	12 x 8 x 50 mm	2
	1.375*	+0.0010 / -0.0000	6.69	2.36	2.95	1.242	0.073	1.518	5/16 x 5/16 x 2-1/2	2
	1.4375	+0.0010 / -0.0000	6.69	2.36	2.95	1.242	0.073	1.605	3/8 x 3/8 x 2-1/2	2
SK 92772.1A / SK 93772.1A	1.500	+0.0010 / -0.0000	6.69	2.36	2.95	1.243	0.073	1.669	3/8 x 3/8 x 2-1/2	2
	30 mm	+0.021 / -0.000 mm	170 mm	60 mm	75 mm	7.85 mm	1.85 mm	33.3 mm	8 x 7 x 60 mm	2
	35 mm	+0.025 / -0.000 mm	170 mm	60 mm	75 mm	7.85 mm	1.85 mm	38.3 mm	10 x 8 x 60 mm	2
	1.500*	+0.0010 / -0.0000	7.56	2.36	3.35	1.242	0.073	1.669	3/8 x 3/8 x 2-1/4	2
	1.4375	+0.0010 / -0.0000	7.56	2.36	3.35	1.242	0.073	1.605	3/8 x 3/8 x 2-1/4	2
SK 92772.1A / SK 93772.1A	40 mm	+0.025 / -0.000 mm	192 mm	60 mm	85 mm	10.15 mm	2.15 mm	43.3 mm	12 x 8 x 60 mm	2
	45 mm	+0.025 / -0.000 mm	192 mm	60 mm	85 mm	10.15 mm	2.15 mm	48.8 mm	14 x 9 x 60 mm	2
	55 mm	+0.025 / -0.000 mm	192 mm	60 mm	85 mm	11.65 mm	2.65 mm	59.3 mm	16 x 10 x 60 mm	2

\* standard size

- Dimensions are in inches unless otherwise noted.
- For shaft sizes not shown, consult NORD.

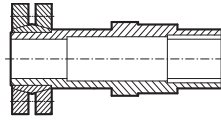

## Shrink Disc Shaft Dimensions (ASH)

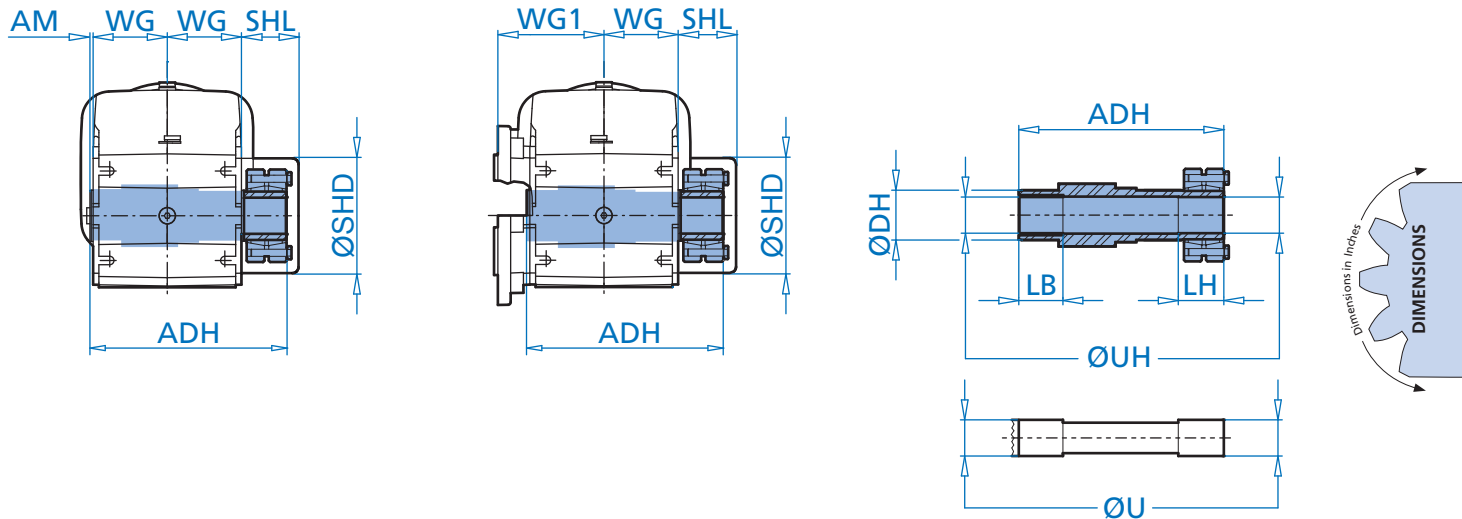

Type	Hollow Shaft						Customer Shaft		Cover		Gear Unit		
	UH	Tolerance	ADH	LB	LH	DH	U	Tolerance	SHL	SHD	WG	WG1	AM
SK 92072.1ASH / SK 93072.1ASH	1.000	+0.0008/-0.0000	5.87	1.22	1.26	1.57	1.000	+0.0000/-0.0005	1.57	2.83	2.28	3.27	0.10
	20mm	+0.021/-0.000mm	149mm	31mm	32mm	40mm	25mm	+0.000/-0.013mm	40mm	71.8mm	58mm	83mm	2.5mm
	25mm	+0.021/-0.000mm	149mm	31mm	32mm	40mm	25mm	+0.000/-0.013mm	40mm	71.8mm	58mm	83mm	2.5mm
SK 92172.1ASH / SK 93172.1ASH	1.000	+0.0008/-0.0000	6.18	1.22	1.38	1.97	1.000	+0.0000/-0.0005	2.01	3.38	2.36	3.62	0.10
	20mm	+0.021/-0.000mm	157mm	31mm	35mm	50mm	25mm	+0.000/-0.013mm	51mm	86mm	60mm	92mm	2.5mm
	25mm	+0.021/-0.000mm	157mm	31mm	35mm	50mm	25mm	+0.000/-0.013mm	51mm	86mm	60mm	92mm	2.5mm
SK 92372.1ASH / SK 93372.1ASH	1.1875	+0.0009/-0.0000	7.13	1.24	1.42	2.36	1.1875	+0.0000/-0.0006	2.52	3.89	2.76	4.72	0.10
	25mm	+0.021/-0.000mm	181mm	31.5mm	36mm	60mm	30mm	+0.000/-0.013mm	64mm	99mm	70mm	120mm	2.5mm
	30mm	+0.021/-0.000mm	181mm	31.5mm	36mm	60mm	30mm	+0.000/-0.013mm	64mm	99mm	70mm	120mm	2.5mm
SK 92672.1ASH / SK 93672.1ASH	1.375	+0.0009/-0.0000	8.27	1.63	1.57	2.95	1.375	+0.0000/-0.0006	2.52	5.03	3.19	4.84	0.16
	30mm	+0.021/-0.000mm	210mm	41.5mm	40mm	75mm	35mm	+0.000/-0.016mm	64mm	128mm	81mm	123mm	4mm
	35mm	+0.025/-0.000mm	210mm	41.5mm	40mm	75mm	35mm	+0.000/-0.016mm	64mm	128mm	81mm	123mm	4mm
SK 92772.1ASH / SK 93772.1ASH	1.500	+0.0009/-0.0000	9.53	1.63	1.73	3.35	1.500	+0.0000/-0.0006	2.64	5.33	3.66	5.47	0.12
	40mm	+0.025/-0.000mm	242mm	41.5mm	44mm	85mm	40mm	+0.000/-0.016mm	67mm	119mm	93mm	139mm	3mm
	45mm	+0.025/-0.000mm	242mm	41.5mm	44mm	85mm	40mm	+0.000/-0.016mm	67mm	119mm	93mm	139mm	3mm

\* Non-shrink disc side diameter larger for clearance.

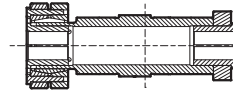

## GRIPMAXX™ Dimensions (AM)

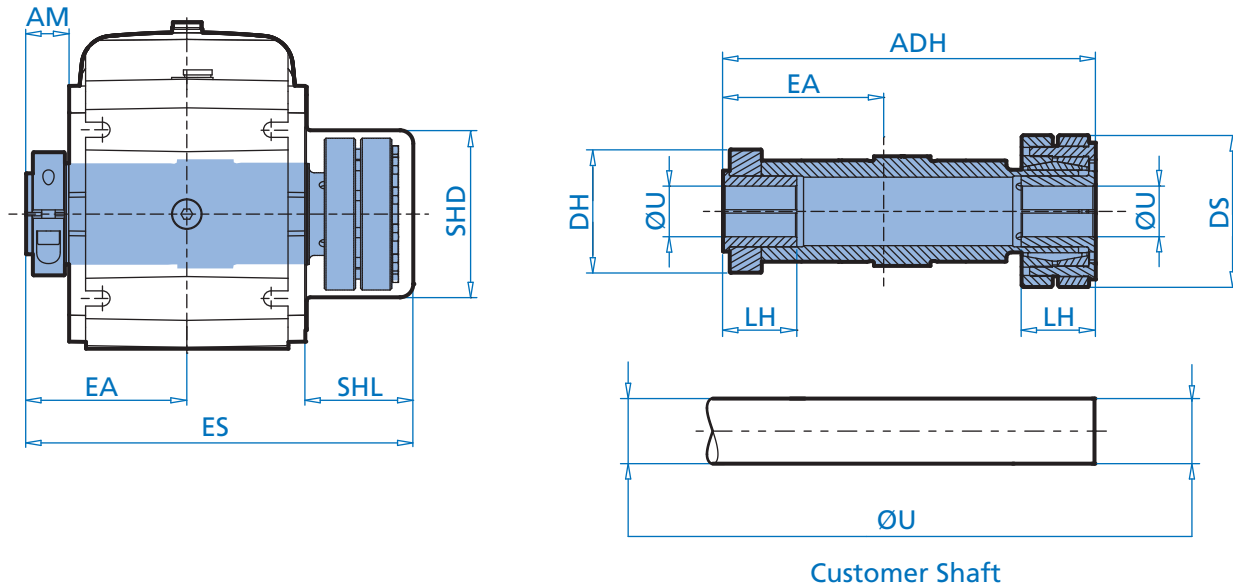

Bore Size Compatibility Chart (ØU)

Customer Shaft Tolerance

Gear Unit Type	ØU Dimension																							
	1/2"	5/8"	3/4"	1"	1-1/8"	1-3/16"	1-1/4"	1-3/8"	1-7/16"	1-1/2"	1-5/8"	1-11/16"	1-3/4"	1-13/16"	1-15/16"	2.000"	20 mm	25 mm	30 mm	35 mm	40 mm	45 mm	50 mm	
SK92072.1AM / SK93072.1AM	X	X	X	X													X	X						
SK92172.1AM / SK93172.1AM		X	X	X	X	X	X										X	X	X					
SK92372.1AM / SK93372.1AM					X	X	X	X	X	X									X	X	X			
SK92672.1AM / SK93672.1AM							X	X	X	X	X	X	X	X	X	X				X	X	X	X	X
SK92772.1AM / SK93772.1AM							X	X	X	X	X	X	X	X	X	X				X	X	X	X	X

V1	V1	ISO 286-2 Tolerance h11(-)
ø [in]	ø [in]	[in]
0.4375	0.6875	- 0.004
0.7500	1.0625	- 0.005
1.1250	1.9375	- 0.006
2.0000	3.1250	- 0.007
ø [mm]	ø [mm]	[mm]
10	18	- 0.11
18	30	- 0.13
30	50	- 0.16
50	80	- 0.19

Gear Unit Type	Hollow Shaft Length	Clamp Ring Width	AM	EA	LH	ADH	ES	DS	DH	SHL	SHD
SK92072.1AM / SK93072.1AM	5.98	0.47	0.69	2.97	1.54	6.69	6.83	2.56	1.89	1.57	2.83
SK92172.1AM / SK93172.1AM	6.56	0.59	0.85	3.21	1.93	7.38	7.58	3.15	2.24	2.01	3.38
SK92372.1AM / SK93372.1AM	7.64	0.75	1.00	3.76	1.73	8.70	9.04	3.54	2.87	2.52	3.89
SK92672.1AM / SK93672.1AM	8.66	0.75	1.06	4.25	1.93	9.72	9.96	4.92	3.23	2.52	5.03
SK92772.1AM / SK93772.1AM	9.72	0.75	1.02	4.69	1.93	10.79	10.98	4.92	3.23	2.64	5.39

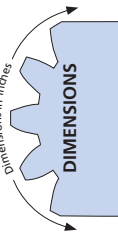
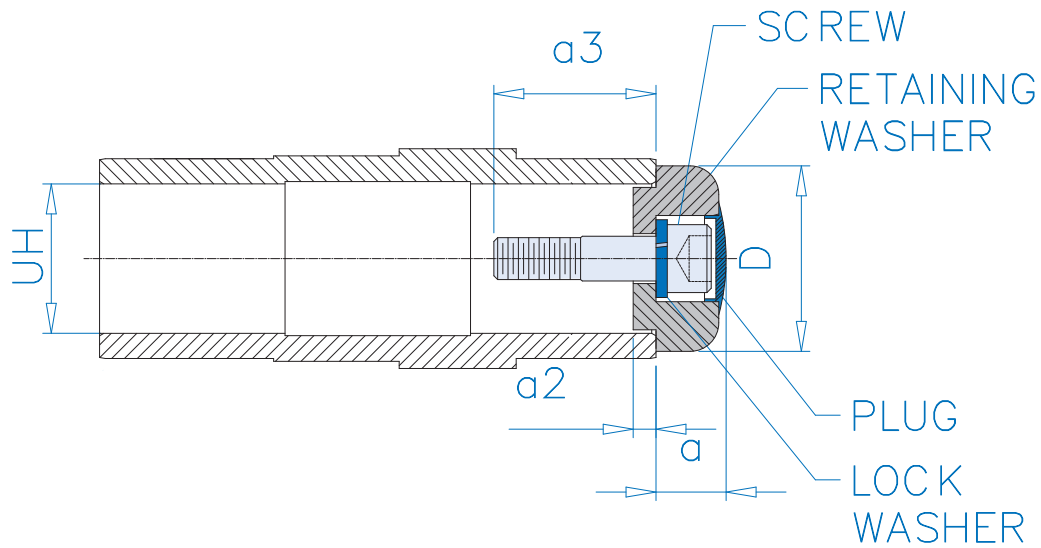
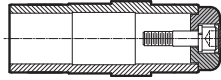

### Inch Shaft Hollow Bore (in)

UH	D	a	a2	Screw ①	a3 ①	Screw ②	a3 ②	Screw ③	a3 ③
0.5000	0.984	0.595	0.110	10 - 32 x 5/8	0.499	-	-	-	-
0.7500	1.181	0.557	0.118	1/4 - 20 x 3/4	0.652	1/4 - 20 x 1	0.902	-	-
1.0000	1.496	0.767	0.150	3/8 - 16 x 3/4	0.624	3/8 - 16 x 1-1/4	1.124	-	-
1.1875	1.575	0.769	0.150	7-16 - 14 x 2-1/16	2.016	-	-	-	-
1.2500	1.575	0.769	0.150	7-16 - 14 x 2-1/16	2.016	-	-	-	-
1.3750	1.772	0.946	0.197	5/8 - 11 x 1-1/2	1.461	5/8 - 11 x 2-1/4	2.211	5/8 - 11 x 1	0.961
1.4375	1.772	0.946	0.197	5/8 - 11 x 1-1/2	1.461	5/8 - 11 x 2-1/4	2.211	5/8 - 11 x 1	0.961
1.5000	1.772	0.946	0.197	5/8 - 11 x 1-1/2	1.461	5/8 - 11 x 2-1/4	2.211	5/8 - 11 x 1	0.961

### Metric Hollow Bore (mm)

UH	D	a	a2	Screw ①	a3 ①	Screw ②	a3 ②
20	30	12	3.0	M6 x 30	28.8	-	-
25	38	19	3.8	M10 x 45	41.8	M10 x 30	26.8
30	40	19	3.8	M10 x 45	43.8	M10 x 30	28.8
35	45	23.5	3.8	M12 x 55	54	M12 x 35	34
40	55	24	8.0	M16 x 70	70	M16 x 45	45

①, ②, ③ - Each fixing element kit may contain up to 3 different kinds of screws



## Motors

- Order Form
- NEMA C-Face Motors
- Engineering Information
- Options
- Environmental Options
- AC Vector Drive Options
- SK 300E Trio  
AC Vector Drive
- Additional Options
- Ratings Tables
- Dimensions
- Connection Diagrams

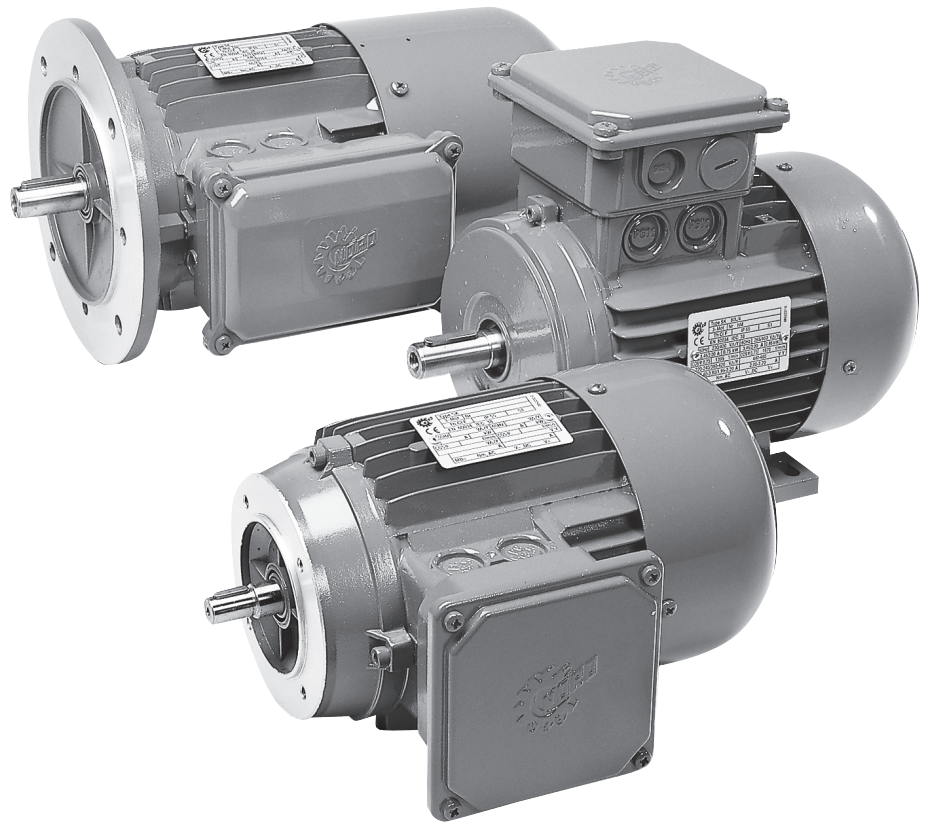

[www.nord.com](http://www.nord.com)

**INVERTER  
DUTY MOTOR**



Motor Type	Power P <sub>n</sub>		n <sub>n</sub> Full-load [rpm]	In Full-Load Current 230V <sup>3</sup> / 460V <sup>3</sup>	
	[hp]	[kW]		[A]	[A]
63S/4	0.16	0.12	1700	0.88	0.44
63L/4	0.25	0.18	1680	1.12	0.56
71S/4	0.33	0.25	1710	1.56	0.78
71L/4	0.5	0.37	1720	1.90	0.95
80S/4	0.75	0.55	1710	2.70	1.35
80L/4	1	0.75	1650	3.66	1.83
90S/4	1.5	1.1	1660	4.84	2.42
90L/4	2	1.5	1660	6.34	3.17
100L/4	3	2.2	1705	9.0	4.50
100LA/4	5	3.7	1725	15.2	7.62
132S/4	7.5	5.5	1735	19.8	9.9
132M/4	10	7.5	1735	25.8	12.9
160M/4	15	11	1770	38.4	19.2

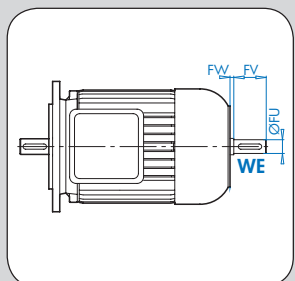



# Motor Order Form

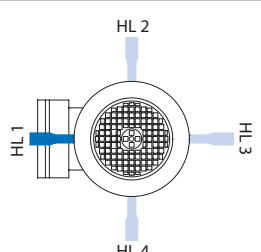

SK	Frame	Size	Poles	Motor Options	Brake Size	Brake Options
	63 71 80 90 100 112 132	S SH SP M MH MP L LA LH LP	4 2 6 4-2 8-2 8-4 12-2 Other	<b>Electrical Motor Options</b> <input type="checkbox"/> H - Energy Efficient Motor <input type="checkbox"/> P - Premium Efficient Motor <input type="checkbox"/> TW - Thermostat <input type="checkbox"/> TF - Thermistor <input type="checkbox"/> SH - Space Heater (select voltage) ○ 110 Volt   ○ 230 Volt   ○ 460 Volt <input type="checkbox"/> ISO H - Class H insulation <input type="checkbox"/> WU - High Resistance Rotor <input type="checkbox"/> 4-2 - 2-Speed, 4/2 Pole, 1800/3600rpm <input type="checkbox"/> 8-2 - 2-Speed, 8/2 Pole, 900/3600rpm <input type="checkbox"/> ECR - Single Phase Motor  <b>Environmental Options</b> <input type="checkbox"/> NSD+ - Nord Severe Duty Paint <input type="checkbox"/> NSDx3 - Nord Extreme Duty Paint <input type="checkbox"/> RD - Canopy Drip Cover <input type="checkbox"/> RDD - Double Fan Cover <input type="checkbox"/> KB - Condensation Drain Holes (plugged) <input type="checkbox"/> KBO - Condensation Drain Holes (open) <input type="checkbox"/> IP66 - IP66 Enclosure Protection <input type="checkbox"/> KKV - Terminal Box Sealed with Resin <input type="checkbox"/> AICM - Additional Insulation <input type="checkbox"/> EP - Epoxy Dipped Windings  <b>AC Vector Drive Related Options</b> <input type="checkbox"/> F - Blower Fan (200-575V 1 & 3 Phase) <input type="checkbox"/> FC - Blower Cooling Fan (115V, 1 Phase) <input type="checkbox"/> IG__ - Incremental Encoder <input type="checkbox"/> IG_P - Incremental Encoder with Plug <input type="checkbox"/> AG - Absolute Encoder <input type="checkbox"/> MG - Magnetic Encoder  <b>Additional Motor Options</b> <input type="checkbox"/> OL - Totally Enclosed Non-Ventilated (TENV) <input type="checkbox"/> OL/H - (TENV) Without Fan Cover <input type="checkbox"/> WE - Second Shaft Extension (Fan Side) <input type="checkbox"/> HR - Hand Wheel <input type="checkbox"/> Z - High Inertia Cast Iron Fan <input type="checkbox"/> RLS - Motor Backstop (rotation viewing fan) ○ Clockwise   ○ Counter-Clockwise <input type="checkbox"/> EKK - Small Terminal Box (not UL approved) <input type="checkbox"/> MS - Quick Power Plug Connector	BRE 5 BRE 10 BRE 20 BRE 40 BRE 60	<input type="checkbox"/> HL - Hand Release Lever <input type="checkbox"/> FHL - Locking Hand Release Lever <input type="checkbox"/> HLH - Hand Release Lever with Hole <input type="checkbox"/> RG - Corrosion Protected Brake <input type="checkbox"/> SR - Dust and Corrosion Protected Brake <input type="checkbox"/> ADJ__Nm - Adjust Brake Torque <input type="checkbox"/> BIP66 - IP66 Brake Enclosure <input type="checkbox"/> MIK - Micro-switch <input type="checkbox"/> BSH - Brake Heating/Bifilar Coil <input type="checkbox"/> NRB1 - Quiet Brake Release <input type="checkbox"/> NRB2 - Quiet Brake Motor Operation <input type="checkbox"/> FBR - Brass Foil <input type="checkbox"/> DBR - Double Brake <input type="checkbox"/> G...P - High Performance Rectifier <input type="checkbox"/> G...V - Sealed Rectifier <input type="checkbox"/> IR - Current Sensing Relay  <b>Rectifier Selection</b> <b>Rectifier Wiring</b> <input type="checkbox"/> Across the line (from motor terminal box) <input type="checkbox"/> Separate power source (frequency AC vector drive, soft starter)  <b>Brake Supply Voltage</b> <input type="checkbox"/> 24 VDC <input type="checkbox"/> 115 VAC <input type="checkbox"/> 200 VAC <input type="checkbox"/> 230 VAC <input type="checkbox"/> 400 VAC <input type="checkbox"/> 460 VAC <input type="checkbox"/> 500 VAC <input type="checkbox"/> 575 VAC <input type="checkbox"/> Other _____  <b>Braking Method*</b> <input type="checkbox"/> Method 10 <input type="checkbox"/> Method 15 <input type="checkbox"/> Method 20 <input type="checkbox"/> Method 25 <input type="checkbox"/> Method 30 <input type="checkbox"/> Method 35 <input type="checkbox"/> Method 40 <input type="checkbox"/> Method 45 <input type="checkbox"/> Method 50 <input type="checkbox"/> Method 55  * More info on page 205  <b>Hand Release Position</b> <input type="checkbox"/> HL 1 <input type="checkbox"/> HL 2 <input type="checkbox"/> HL 3 <input type="checkbox"/> HL 4 
	<b>Paint</b> <input type="checkbox"/> Unpainted Aluminum Alloy <input type="checkbox"/> Stainless Steel Paint <input type="checkbox"/> NSD+ (gray) <input type="checkbox"/> NSD+W (white) <input type="checkbox"/> NSD-X3 (gray) <input type="checkbox"/> NSD-X3W (white) <input type="checkbox"/> Special _____					



### Mounting

- Integral to gearbox
- NEMA C-Face
- NEMA T-Footed
- IEC B5 Mount
- IEC B14 Mount
- IEC B3-Footed

### Voltage & Frequency

- 230/460V-60Hz
- 575V-60Hz
- 208V-60Hz
- 400V-50Hz
- 115/230V, 60Hz-1-ph.
- Other

### Terminal Box Pos.

- TB1
- TB2
- TB3
- TB4

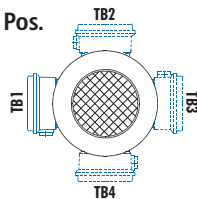

Mtg. Pos. M1 Shown

### Conduit Entry Loc.

- CE I \*
- CE II
- CE III \*
- CE IV

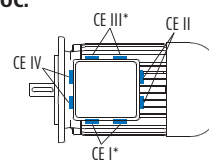

\*Brakemotor

Mtg. Pos. M1 Shown



## NEMA C-Face Motors

The National Electrical Manufacturers Association (NEMA) provides standardization of electrical equipment, enabling customers to select from a range of safe, effective and compatible products. A NEMA C-face motor has a machined face with a pilot and threaded holes for direct mounting onto a NORD reducer or other industrial equipment. NORD offers NEMA C-face motors stocked as finished goods and will also assemble NEMA C-face motors to your specifications. For ratings, see page 168.

## Stocked NEMA C-Face Motors

Stocked NEMA C-face motors are offered in standard efficiency, energy efficient and in a brakemotor design. They are available in 230/460V-60Hz and 575V-60Hz up to 10 hp. Part numbers for stocked NEMA C-face motors are in the table below.

## Assembled per Order NEMA C-Face Motors

NORD will assemble a NEMA C-face motor to your specifications based upon the available motor options from this catalog.

Motor Type	Power	Part Number 230/460V-60Hz	Part Number 575V-60Hz	Weight [lb]
<b>High Performance Motors</b>				
63S/4-56C	1/6 hp	31110012	31110013	7.9
63L/4-56C	1/4 hp	31610012	31610013	9.3
71S/4-56C	1/3 hp	32110012	32110013	11.9
71L/4-56C	1/2 hp	32610012	32610013	13.9
80S/4-56C	3/4 hp	33110012	33110013	17.6
80L/4-56C	1 hp	33610022	n/a	19.8
<b>Energy Efficient Motors <sup>ee</sup></b>				
80LH/4-56C	1 hp	33610094	33610095	19.8
80LH/4-143TC	1 hp	33610092	33610093	19.8
90SH/4-145TC	1.5 hp	34110092	34110093	26.5
90LH/4-145TC	2 hp	34610092	34610093	30.9
100LH/4-182TC	3 hp	35610092	35610093	39.7
112MH/4-184TC	5 hp	36110082	36110083	83.6
132SH/4-213TC	7.5 hp	36410092	36410093	97.0
132MH/4-215TC	10 hp	36710092	36710093	121.3
<b>Premium Efficient Motors <sup>pe</sup></b>				
80 LP/4-56C TW	1 hp	33610294	33610295	
80 LP/4-143TC TW	1 hp	33610292	33610293	22.5
90 SP/4-145TC TW	1.5 hp	34110292	34110293	33.3
90 LP/4-145TC TW	2 hp	34610292	34610293	36.8
100 LP/4-182TC TW	3 hp	35110292	35110293	55.6
112MP/4-184TC TW	5 hp	36110292	36110293	78.3
132 SP/4-213TC-TW	7.5 hp	36410292	36410293	121.3
132 MP/4-215TC-TW	10 hp	36710292	36710293	136.7
<b>Brakemotors</b>				
63S/4-56C BRE5 HL	1/6 hp	31110034 ♦	31110035 *	12.4
63L/4-56C BRE5 HL	1/4 hp	31610034 ♦	31610035 *	13.7
71S/4-56C BRE5 HL	1/3 hp	32110034 ♦	32110035 *	16.3
71L/4-56C BRE5 HL	1/2 hp	32610034 ♦	32610035 *	18.3
80S/4-56C BRE10 HL	3/4 hp	33110034 ♦	33110035 *	24.3
80L/4-56C BRE10 HL	1 hp	33610024 ♦	33610025 *	26.5
80L/4-143TC BRE10 HL	1 hp	33610034 ♦	33610035 *	26.5
<b>Energy Efficient Brakemotors <sup>ee</sup></b>				
80LH/4-56C BRE10 HL	1 hp	33610082 ♦	33610083 *	19.8
80LH/4-143TC BRE10 HL	1 hp	33610084 ♦	33610085 *	19.8
90SH/4-145TC BRE20 HL	1.5 hp	34110084 ♦	34110085 *	26.5
90LH/4-145TC BRE20 HL	2 hp	34610084 ♦	34610085 *	30.9
100LH/4-182TC BRE40 HL	3 hp	35110084 ♦	35110085 *	39.7
112MH/4-184TC BRE40 HL	5 hp	36110084 ♦	36110085 *	83.6
132SH/4-213TC BRE60 HL	7.5 hp	36410084 ♦	36410085 *	123.4
132MH/4-215TC BRE100 HL	10 hp	36710084 ♦	36710085 *	156.5
<b>Premium Efficient Brakemotors <sup>pe</sup></b>				
80LP/4-56C BRE10 HL	1 hp	33610282 ♦	33610283 *	19.8
80LP/4-143TC BRE10 HL	1 hp	33610284 ♦	33610285 *	19.8
90SP/4-145TC BRE20 HL	1.5 hp	34110284 ♦	34110285 *	26.5
90LP/4-145TC BRE20 HL	2 hp	34610284 ♦	34610285 *	30.9
100LP/4-182TC BRE40 HL	3 hp	35110284 ♦	35110285 *	39.7
112MP/4-184TC BRE40 HL	5 hp	36110284 ♦	36110285 *	83.6
132SP/4-213TC BRE60 HL	7.5 hp	36410284 ♦	36410285 *	123.4
132MP/4-215TC BRE100 HL	10 hp	36710284 ♦	36710285 *	156.5

♦ 230/460V motors have brake systems supplied with 230VAC to a GVE20L rectifier that outputs 205VDC to the brake coil

\* 575V motors have brake systems supplied with 575VAC to a GHE50L rectifier that outputs 250VDC to the brake coil





## Standards

All motors are in accordance with existing standards and regulations:

### NEMA MG 1 - Motors and Generators:

- Electrical performance
- Motors for operation on variable AC vector drive

### UL 1004 – Electric Motors

### CSA C22.2 No. 100-04 - Motors and Generators:

### Industrial Products

### IEC 60034 parts 1, 5, 6, 8, 9, 11, 12 and 14.

- Part 1 – General rules
- Part 5 – Types of enclosures
- Part 6 – Types of cooling
- Part 8 – Terminal lead designations and sense of rotation
- Part 9 – Noise limits
- Part 11– Integrated thermal protection
- Part 12– Starting Performance
- Part 14– Mechanical vibration

## INVERTER DUTY MOTOR

### Inverter/Vector Duty

NORD single-speed motors are Inverter/Vector Duty. The construction of the NORD motors insulating system takes into account the non-sinusoidal wave forms produced by variable frequency drives. NORD uses high grade insulating components and extra first turn protection as well as double coated wire to ensure long service life when connected to AC vector drives. NORD motors can produce full torque at zero speed if properly sized, selected and controlled.

## IEC 60038 – Standard voltages

	NORD motors carry the CE mark in accordance with the Low Voltage Directive and, if installed properly, the Electromagnetic Compatibility Directive (EMC). The CE mark is required for installation in European Union (EU) states.
	Many NORD motors from frame size 63 to 315 are an Underwriters Laboratories Recognized component per UL standard 1004. Frames 63-180 File number E191510 Frames 200+ File number E227215
	The Canadian Standards Association CUS mark indicates that CSA has tested and approved NORD motors according to both US and Canadian standards. It is equivalent to the Underwriters Laboratories RU recognition mark (UL standard 1004) and the CSA mark according to CSA Standard C22.2 No. 100-04 Frames 63-180 File number LR112560 Frame 200+ File number LR13494
	NORD Energy Efficient motors up to frame 180 have been evaluated by the United States Department of Energy and received a Certificate of Compliance to certify the efficiency ratings. The certificate of compliance is CC 092B.
	NORD Premium Efficient motors up to frame 180 have been evaluated by the United States Department of Energy and received a Certificate of Compliance to certify the efficiency ratings. The certificate of compliance is CC 092B.
	NORD energy efficient motors carry the CSA energy efficiency verification mark. This mark ensures that CSA has verified that NORD motors are designed and manufactured to meet energy efficiency requirements number EEV112560.
	China Compulsory Certification Nr.: 200 701 040 125 842 9
	GOST® certificate for the import of motors into Russia.

For more information on current motor efficiency regulations please see page 178.



## Standard Motor Construction

Our motors are an important part of our ability to provide a high quality, competitive, and complete drive system. NORD motors are designed for across the-line or inverter/vector duty operation. NORD motors are constructed with superior insulating methods to provide excellent moisture protection, low temperature rise, and voltage spike resistance in accordance with NEMA MG1. Low rotor inertia and high starting torque allow peak performance in difficult applications involving high start/stop cycling rates or rapid acceleration/deceleration. Standard motors offer protection from the elements with many standard and optional design features.

Some of the standard design benefits include:

- Shaft lip seals on both ends of the motor shafts.
- Stator to endbell connections sealed to exclude moisture.
- Double coated magnetic wire insulation.
- Inverter/vector duty insulation system conforms to NEMA MG1-2009, section 31.4.4.2 voltage spikes.
- Moisture resistant varnish dipped windings with improved varnish materials.
- Inorganic insulating components for tropical protection.
- Conduit box sealed with gaskets.
- Corrosion resistant alloy materials.
- Threaded cable entry holes.

## Terminal Block

Each NORD motor uses a terminal block, which is a superior method of wire termination when compared to pigtail leads. A terminal block ensures long-term reliability of the power connections.

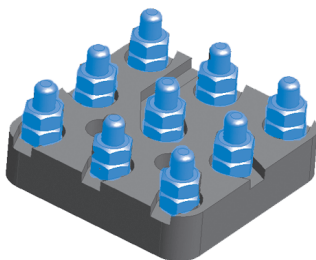

## Non-Sparking Fan

The standard NORD motor fan is a non-sparking design. The fan will also provide proper airflow in either direction of rotation.

## Inverter/Vector Duty – Voltage Spikes

All NORD motors are constructed with an insulating system designed to withstand the repeated voltage spikes generated by modern AC vector drives. The insulation system withstands the ratings in conformance with NEMA MG 1-2009 Section 31.4.4.2 Voltage Spikes.

$$V_{\text{peak}} = 3.1 \times V_{\text{rated}} \text{ with a Rise time } \leq 0.1\mu\text{s.}$$

## Insulation System

The NORD motor insulation system is designed to provide a superior degree of protection. NORD utilizes the following insulation components:

- Magnet wire – double coated insulation
- Varnish dip impregnation
- Slot liners
- Phase paper & separators
- Top sticks
- Wire sleeve connectors

Other motor manufacturers eliminate some of these insulating components for cost reduction which leads to less reliability.

## Tropical Protection (Anti-fungal)

As a standard the NORD motor insulation system is tropically protected. The insulating and construction components are made of inorganic materials that resist fungal growth.

## Low Inertia

The motor inertia in all NORD motors is extremely low which allows for an increased dynamic motor control capability. Low motor inertia is a significant advantage when using NORD motors with AC vector drives or controllers. NORD motors have the ability to cycle more frequently and require less mechanical energy to start than the standard NEMA frame motors. This leaves more energy to start the load.

## High Torque

NORD motors produce a higher starting torque than what is required by NEMA standards. This is achieved through improved motor winding, rotor design and construction.

## Service Factor

NORD motor's with ratings of either 230/460V-60Hz and 332/575V-60Hz have a service factor of 1.15. Almost all other motors have a service factor of 1.1 or 1.0.





## Poles / speeds

NORD offers a variety of single and two speed motors in addition to the standard 4 pole motor. NORD single speed motors are inverter/vector duty rated, however, it is not recommended to run a NORD two speed motor with an AC vector drive.

Number of Poles	Synchronous Speed at 60Hz	Synchronous Speed at 50Hz	Notes:
<b>Single Speed Motors</b>			
4	1800 rpm	1500 rpm	–
2	3600 rpm	3000 rpm	–
6	1200 rpm	1000 rpm	–
<b>Two Speed Motors</b>			
4-2	1800/3600 rpm	1500/3000 rpm	Single winding
8-2	900/3600 rpm	750/3000 rpm	Two winding
8-4	900/1800 rpm	750/1500 rpm	Single winding

Other speeds available upon request.

## Voltage and Frequency

NORD motors are available in a number of voltage and frequency options. All standard voltages are commonly available. Optional voltages may be provided, but may include an increase in price and an extended lead time. It also may be possible to provide motors with special voltages and frequency operation points.

### Standard Voltages

Single speed motors	Two speed motors
230/460V-60Hz (up to 30 hp)	460V-60Hz
460V-60Hz (40 hp and larger)	230V-60Hz
575V-60Hz	575V-60Hz
400V-50Hz	400V-50Hz

### Optional Voltages

Single speed motors	Two speed motors
208V-60Hz (up to 10 hp, not available in energy efficient design)	Other voltages & frequencies available upon request
380V-50Hz	
415V-50Hz	
380V-60Hz	
Other voltages & frequencies available upon request	

## Voltage and Frequency Variation

Voltage and frequency variations are based upon the assumption that the nameplate horsepower will not be exceeded and that the motor temperature may increase. Standard allowable deviations are based upon the type of motor labeling.

### NEMA and CSA Labeled Motors



Variations are based upon the nominal utilization voltage, and not the service (supply) voltage as per ANSI C84.1. Voltage and frequency tolerances follow the guidelines set forth in NEMA MG-1.

Service Voltages	Utilization Voltages
120V	115V
208V	200V
240V	230V
480V	460V
600V	575V

- Approved voltage variation at rated frequency is  $\pm 10\%$ .
- Approved frequency variations at rated voltage is  $\pm 5\%$ .
- Approved combined voltage/frequency variation =  $\pm 5\%$ .

### US and Canadian Standard (CUS)

CUS motor construction defines that NORD motors are constructed in accordance to UL 1004 (electric motors) and CSA C22.2 No. 100-04 (motors and generators) guidelines. This option is standard for 208, 230, 460, and 575 Volt operation at 60 Hz.

Motors nameplated with the CUS option will be marked  and  indicating that the Underwriters Laboratories and CSA have tested and approved NORD motors according to both US and Canadian standards.

### CE Labeled Motors

Per IEC 60038, allowable service voltage variations on in the current system, compared to the previous system, are as indicated.

Previous Service Voltages	Current Service Voltages
220V, 380V, 660V	230V, 400V, 690V +6/-10%
240V, 415V	230V, 400V +10/-6%

- Per EN 60034-1, a  $\pm 5\%$  voltage variation and a  $\pm 2\%$  frequency variation can be tolerated.
- The allowed variations are based upon the voltage (or voltage range) indicated on the motor nameplate.





## Insulation Class

NORD motors are constructed with a thermal class F insulating system. These motors are also designed for a class B temperature rise of up to 80°C. The use of class F insulation with a class B temperature rise provides increased operating life. Motors constructed with class H insulation are also available as an option.

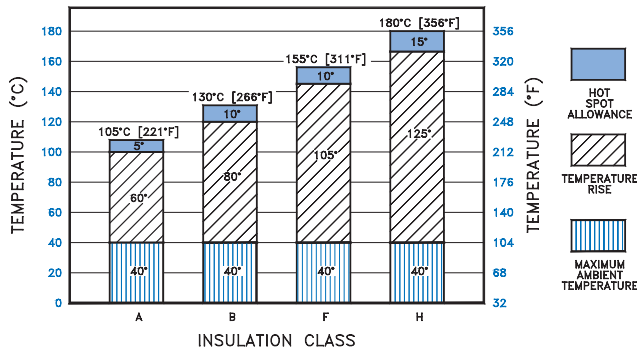

## Ambient Temperature

NORD motors are designed to operate with a maximum ambient temperature of 40°C (104°F). If the motor's operating environment exceeds 40°C, the motor's nominal power  $P_n$  either needs to be de-rated (see table below) or use upgraded insulation.

Ambient temp [°F]	113	122	131	140
Ambient temp [°C]	45	50	55	60
De-rate factor	0.96	0.92	0.87	0.82

$$\text{Motor Rated Power} = [P_n \times \text{De-rate factor}]$$

## Elevation

NORD motors are designed to operate at an elevation of up to 3300 ft (1000 m) above sea level. At higher elevations the air is thinner resulting in less cooling capacity. If the motor's nominal power ( $P_n$ ) installation elevation exceeds 3300 ft (1000 m), the motor's nominal power either needs to be de-rated (see table below) or requires upgraded insulation.

Altitude [ft]	5000	6500	8200	10000	11500	13000
Altitude [m]	1500	2000	2500	3000	3500	4000
De-rate Factor	0.97	0.94	0.90	0.86	0.83	0.80

$$\text{Motor Rated Power} = [P_n \times \text{De-rate factor}]$$

## Enclosure

The NORD standard motors are provided with Totally Enclosed Fan-Cooled (TEFC) with an IP55 enclosure rating. Other enclosures are available, including Totally Enclosed Non-Ventilated (TENV), Totally Enclosed Blower-Cooled (TEBC), and IP66.

The motor integral cooling fan provides proper air flow in either direction of rotation. The IEC cooling classification is IC 411 according to IEC 60034-6.

## IP Enclosures per IEC 60034-5 - Simplified

1st digit Foreign body protection	2nd digit Water protection
0 No protection	0 No Protection
1 Protected against solid objects 50mm (2 in) in diameter and larger	1 Protected against dripping water
2 Protected against solid objects 12 mm (1/2 in) in diameter and larger	2 Protected against dripping water up to a 15 degree angle
3 Protected against solid objects 2.5 mm (0.1 in) in diameter and larger	3 Protection against sprayed water
4 Protected against solid objects 1 mm (0.04 in) in diameter and larger	4 Protection against splashed water
5 Protected against dust	5 Protection against water jets
6 Dust tight	6 Protection against high pressure water jets
7 --	7 Protection against intermittent submersion in water
8 --	8 Protection against continuous submersion in water





## Duty Classes

The following duty types are defined in IEC 60034-1.

Duty Type	Explanation Excerpts
S1	Continuous operation at a constant load, the motor reaches thermal equilibrium
S2	Short-time operation at a constant load for a given time followed by a time of rest until the motor is completely cooled down to ambient temperature. Example: S2-10 minutes Recommended values for determination: 10, 30 min.
S3	Sequential intermittent operation, identical run and rest cycles with a constant load. Temperature equilibrium is never reached. Starting current has little effect on temperature rise. The cyclic duration factor (cdf) indicates the portion of operation time in relation to a complete duty cycle. The typical duty cycle time is 10 minutes, unless otherwise specified. Example: S3-40% Recommended values for determination: 25, 40, 60%
S6	Continuous operation with intermittent load sequential, identical cycles of running with constant load and running with no load. No rest periods. Example: S6-40% Recommended values for determination: 25, 40, 60%

## Power Increasing Factor for Short-term & Intermittent Operation

Motor ratings in this catalog are based on continuous duty operation (S1). If a motor is designed for S1 duty, but is to be operated for short-time or intermittent operation it can be subjected to higher loads. The available motor power can be raised above the motor rated power by the "increasing factor" in the table below.

Duty Type		Increasing factor	
S2	Operating time	10 min	1.40
		30 min	1.15
S3	Cyclic duration factor (cdf)	25%	1.33
		40%	1.18
		60%	1.08
S6	Cyclic duration factor (cdf)	25%	1.45
		40%	1.35
		60%	1.15

Motor Rated Power =  $[P_n \times \text{Increasing factor}]$

## Protective Features

All NORD Motors and Speed Reducers are constructed to provide a high degree of protection against wet and severe environments. NORD motors and speed reducers are sealed against moisture ingress and use corrosion and moisture resistant components. NORD has recently made many enhancements in the motor and gear units standard construction to provide improved environmental protection. Many of the standard protection features of the NORD units are only available at an additional cost from other motor and gear drive suppliers. NORD designs all gearmotors, speed reducers and motors for installation in harsh industrial, commercial and municipal installation environments.

### Motors for Indoor Operation - Option Codes

	Dry Conditions	Wet or Humid Conditions
Ambient Temperature Fluctuation	–	KB, SH
Paint	–	NSD+
Vertical Motor Mount 	RD	RDD

### Motors for Outdoor Operation - Option Codes

	Sheltered from the Elements	Exposed to the Elements
Ambient Temperature Fluctuation	KB, SH	KB, SH, KKV
Paint	NSD+	NSDx3
Vertical Motor Mount 	RD	RDD

### Option Code Key

KB	Condensation Drain Holes - Plugged	Page 156
SH	Space Heater	Page 155
KKV	Terminal Box Sealed with Resin	Page 156
NSD+	NORD Severe Duty Paint	Page 26
NSDx3	NORD Severe Extreme Duty X3 Paint	Page 26
NSD <sup>tuph</sup>	Tuph Sealed Surface Conversion	Page 27
RD	Canopy Drip Cover	Page 156
RDD	Double Fan Cover	Page 156





## Motor Options & Construction

NORD motors are stocked in one of two ways. The first method is to stock a complete motor that is ready to be assembled to a gear reducer or shipped as a stand alone motor. The second method, the motor is assembled from component parts. The **Mod** next to a motor option designates that the option can be added to a complete motor by simple modification. The **Build** next to a motor option indicates that the motor will need to be built from component parts in order to incorporate the motor option.

### Motor Options

Abbreviation	Description	Mod	Build	Page
AG	Absolute Encoder		✓	164
AICM	Additional Insulation		✓	156
ECR	Single Phase Motors, 60Hz		✓	155
EKK	Small Terminal Box	✓		159
EP	Epoxy Dipped Windings		✓	156
F	Blower Cooling Fan	✓		160
FC	Blower Cooling Fan	✓		160
HR	Hand Wheel		✓	157
IG...P	Incremental Encoder		✓	163
ISO H	Class H Insulation		✓	155
KB	Plugged Condensation Drain Holes		✓	156
KBO	Open Condensation Drain Holes		✓	156
KKV	Terminal Box Sealed with Resin	✓		156
MG	Magnetic Encoder			162
MS	Quick Power Plug Connector	✓		159
OL	Totally Enclosed Non-Ventilated	✓		157
OL/H	Totally Enclosed Non Ventilated without Fan Cover		✓	157
RD	Canopy Drip Cover	✓		156
RDD	Double Fan Cover	✓		156
RLS	Motor Backstop		✓	158
SH	Space Heater		✓	155
TF	Thermistor		✓	154
TW	Thermostat		✓	154
WE	2nd Shaft Extension on Fan Side		✓	157
WU	High Resistance Rotor		✓	155
Z	High Inertia Cast Iron Fan		✓	158
-	IP65 Enclosure Protection	✓		156
-	IP66 Enclosure Protection	✓		156
-	Paint Coatings	✓		26





## Motor Protection

Selecting appropriate motor protection is a key factor in reliable motor operation. There are two common classes of motor protection; current based and temperature based. Electrical installation codes require at least two types of protection in the motor circuit, both of which are normally current based. First is short-circuit protection, normally accomplished by fuses or circuit breakers. The Second is "motor overload protection" and is normally

a device called a "motor overload" or a "heater." Current based protection is effective in some conditions. NORD can provide two different types of motor temperature based protection, a PTC thermistor (TF) or a bi-metallic thermostat (TW). Temperature based protection is more effective motor protection in many situations, this is explained in the table below.

↑ = Good protection ↔ = Limited protection ↓ = No protection	Fuses	Motor Overloads	PTC Thermistor (TF)	Bi-metallic Switch (TW)
Over current up to 200%	↓	↑	↑	↑
High inertia starting	↓	↔	↑	↔
Frequent motor starts	↓	↔	↑	↑
Stalling	↔	↔	↔	↔
Single phasing	↓	↔	↑	↑
Supply voltage deviations	↓	↑	↑	↑
Supply frequency deviations	↓	↑	↑	↑
Inadequate motor cooling	↓	↓	↑	↑
Bearing Damage	↓	↓	↑	↑

## Thermostats (TW & 2TW)

Build

Motor thermostats or bi-metallic switches can be wired directly into the control circuit without a separate control module or tripping device. Thermostats operate on a relatively high control voltage so they are much less sensitive to voltage interference from the main power supply. One may often run thermostat leads and motor power leads next to each other when using the appropriate shielded cable. The installer is responsible for wiring the thermostats onto the motor control circuit. The leads may be labeled in a variety of ways as indicated.

Standard connection	Series connected, one per phase
Contact	NC (Normally Closed)/ Auto Re-setting
Response Temperature (Option TW)	311 °F (155 °C) Shut-Off Device
Response Temperature (Option 2TW)	311 °F (155 °C) Shut-Off Device + 266°F (130 °C) Alarm Device
Nominal Current	1.6 Amp at 250 V
Resistance	< 50 mΩ
Switch Rebound	< 1ms
Insulation Rating	2000 VAC
Cycles	10,000 max
Lead Identification (inside terminal box)	P1 and P2 or TB1 and TB2 / 2TB1 and 2TB2

## Thermistors (TF)

Build

With a separate control module or tripping device (ex. Kirwan INT69) thermistors are used to sense overload and temperature conditions by converting the critical operating temperature limit into internal resistance changes. Due to their small size, heat sink construction, and high change in resistance value, minor resistance variations caused by relatively long lead runs may be tolerated. This feature also allows for one controller to be used for several temperature sensing locations. Many variable frequency drives come with on-board thermistor inputs. NORD does not supply the thermistor control module.

Standard Connection	Three devices, series connected, one per phase
Type	Positive temperature coefficient (PTC)
Transition Temperature	150°C±5 °C
Resistance	20... 500Ω (below transition) > 4 kΩ (above transition)
Reed Current	< 1mA
Max Voltage	30V
Lead Identification (inside terminal box)	P1 and P2 or TP1 and TP2



### WARNING



- Thermostats and Thermistors will automatically reset.
- All wiring must be completed by qualified personal and adhere to all local installation codes.



## Space Heater (SH)

Build

Motors subjected to extreme temperature fluctuations or severe climatic conditions can be damaged by the formation of condensation. NORD can provide anti-condensation space heaters inside the motor to heat up the windings when the motor is not operating. This will prevent moisture from forming inside the motor. The space heaters must not be switched on while the motor is running.



### Space Heater Voltage Must be specified

#### Voltages available

- 115V – 50/60Hz
- 230V – 50/60Hz
- 460V – 50/60Hz
- other voltages available on request

## Class H Insulation (ISO H)

Build

NORD motors can be manufactured with a class H insulation system. Standard NORD motors include double coated magnetic wire windings. When these windings are paired with a class H insulation it provides extra temperature capacity for the motor and will increase the motor's life. Class H insulation rated motors are also an advantage in some severe applications such as:

- Increased ambient temperature installations above 40°C (104°F)
- Increased elevation installations – above 3300 ft (1000 m)
- Applications with a high number of starts per hour.
- A lower operating frequency such as when used with an AC vector drive
- For additional information on insulation class see page 151.

## High Resistance Rotor (WU)

Build

Using Silumin rotor material, NORD offers a high resistance rotor to soften the motors operation and allow higher overload torques.

## Single Phase Motors, 60Hz (ECR)

Build

The ECR series of single phase motors is intended for demanding operation at 60Hz with a supply voltage of 115V or 230V. The permissible voltage range is 115/230V +/- 10%. The ECR motors have a 1.15 service factor and are available from 0.16 - 2 hp.





## Paint Coatings Mod

NORD's standard paint coating is a two component, aliphatic polyurethane finish containing 316 stainless steel material. This gray stainless steel paint has excellent appearance and outstanding physical properties. It is suitable for both indoor and outdoor applications. For more information and an explanation of all of our paint options please see page 26.

## Condensation Drain Holes

NORD motors can be equipped with condensation drain holes. These drain holes are placed in the motor endbells at the lowest possible point. The drain holes are closed at the factory with plastic snap in plugs. They allow for condensation accumulation in the motor to drain after the closing plugs are removed.

The motor drain holes can be provided by NORD either open (KBO) or sealed with a closing plug (KB).



### IMPORTANT NOTE



The motor must be installed in the mounting orientation specified on the nameplate or the drain holes will not function properly and may result with the motor filling with water.

## Condensation Drain Holes, Plugged (KB) Build

KB drain holes are plugged for shipment. In order for the holes to effectively drain moisture, the plugs must be removed before using the motor.

## Condensation Drain Holes, Open (KBO) Build

KBO drain holes are shipped open (not plugged).

## IP65 Enclosure Protection Mod

NORD motors can be provided with an IP65 enclosure protection. IP65 protection is suitable for wet, low-pressure wash down and extremely dusty environments.

IP	1 <sup>st</sup> digit Foreign body protection	IP	2 <sup>nd</sup> digit Water protection
6	Dust tight	5	Protection against water jets

## IP66 Enclosure Protection Mod

NORD motors can be provided with an IP66 enclosure protection. IP66 protection is suitable for wet, high-pressure wash down and extremely dusty environments, and includes all requirements included in IP65 enclosure protection.

IP	1 <sup>st</sup> digit Foreign body protection	IP	2 <sup>nd</sup> digit Water protection
6	Dust tight	6	Protection against high pressure water jets

## Terminal Box Sealed with Resin (KKV) Mod

Terminal boxes may be sealed with a flexible, electrically safe resin to ensure that contaminants, water, and moisture cannot pass through the terminal box into the stator body. This option is helpful in extremely dusty, wet and humid environments. Another environment where this option is helpful is in installations that have frequent large temperature swings where condensation may form.

## Additional Insulation (AICM) Build

NORD can provide additional insulation inside the motor to provide additional electrical protection in extremely wet or corrosive environments. An electrically safe insulating material is coated internally in the stator windings and on the rotor body.

## Epoxy Dipped Windings (EP) Build

In extremely wet environments, the motor windings are dipped in epoxy for improved moisture protection. The motor can also be treated with the standard NORD Severe Duty + (NSD+) package for an even higher degree of protection.

## Canopy Drip Cover (RD) Mod

For wet or dirty installations where the fan end of the motor is mounted up, NORD offers a canopy drip cover to block this falling water or debris, thus forcing water or debris to repel from the motor's fan guard, .



## Double Fan Cover (RDD) Mod

For wet or dirty installations where the fan end of the motor is mounted up, the NORD Double Fan Cover provides protection against falling or wind blown water, snow, dirt or debris from entering the back of the motor.





## Totally Enclosed Non-Ventilated (OL) Mod

NORD can provide totally enclosed non-ventilated (TENV) motor enclosure. TENV motors provide benefits in certain operating environments; such as extremely dusty or dirty applications, where cooling fans may have material accumulation, which can be detrimental to the motor and the application. The OL series of motors are the standard fan cooled motor construction including the fan cover, but provided without the fan. TENV motors can also be used to reduce cooling fan noise on a standard motor.

A TENV motor's frame size is larger than a totally enclosed fan cooled (TEFC) motor. For intermittent operation, a TENV motor can be operated at a 50% duty cycle at full rated power.

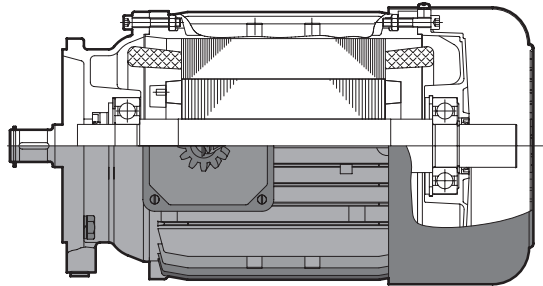

## Totally Enclosed Non-Ventilated, without Fan Cover (OL/H) Build

The OL/H series of TENV motors are more compact in space than the OL series. They do not include the rotor shaft extension through the back bearing end bell or the fan cover.

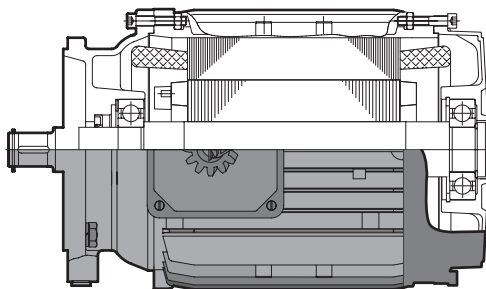

## 2nd Shaft Extension on Fan Side (WE) Build

NORD can provide a second shaft extension on the fan side of the motor that protrudes through the fan cover. This extension can be used as a power take-off or to mount customer supplied devices such as encoders and tachometers.

The shaft extension can be provided on motors with and without brakes. The shaft extension can not be used on motors with blower fans (F) or (FC). For dimensions see pages 192 - 198.

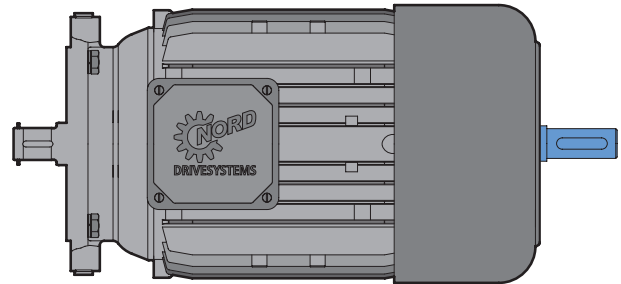

## Hand Wheel (HR) Build

Motors can be supplied with a hand wheel that is located on the second shaft extension. The hand wheel can be used for manual operation during power outages, or for machine positioning setup. This option is not available on NEMA dimensioned motors. For dimensions see pages 192 - 198.

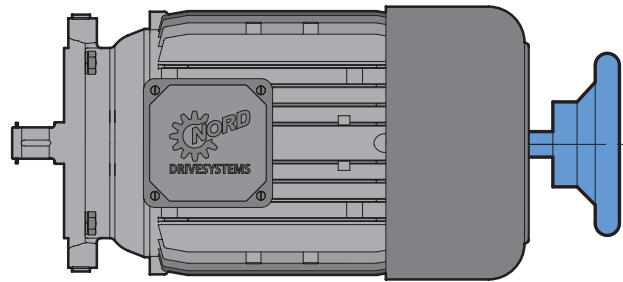

⚠
WARNING
⚠

The customer is required to provide appropriate safety guarding for the rotating hand wheel.



# Additional Options



## High Inertia Cast Iron Fan (Z)

Build

An optional cast iron motor cooling fan is available. This fan is used as a mechanical soft start and/or soft stop. This fan adds inertia to the motor. The high inertia fan can also be used for a flywheel effect to store mechanical energy. This can be helpful in smoothing rapid load changes. The cast iron fan replaces the standard plastic motor fan. The motor length is the same as a brakemotor.

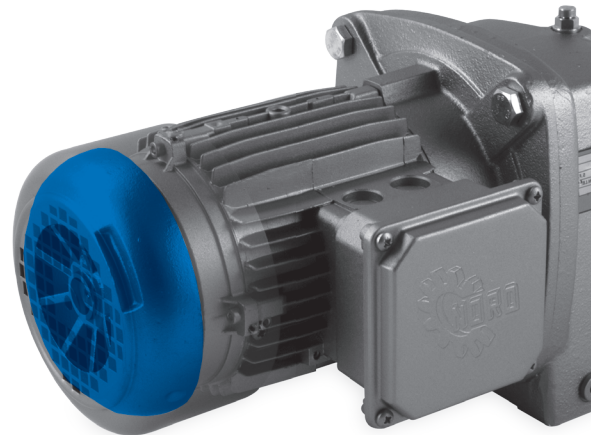

Motor Frame	Fan Inertia $J_2$ [lb-ft <sup>2</sup> ]
71	0.0475
80	0.1140
90	0.2375
100	0.2684
112	0.5653
132	0.9500

## Motor Backstop (RLS)

Build

NORD can provide backstops on many motor frames. A backstop will prevent the motor from rotating in one direction. A common use is to prevent a motor from allowing a load to move backwards when power is removed. A motor brake is an alternative that may be used for this same purpose. A backstop adds additional length to the motor. For the motor length extension, see the table below.

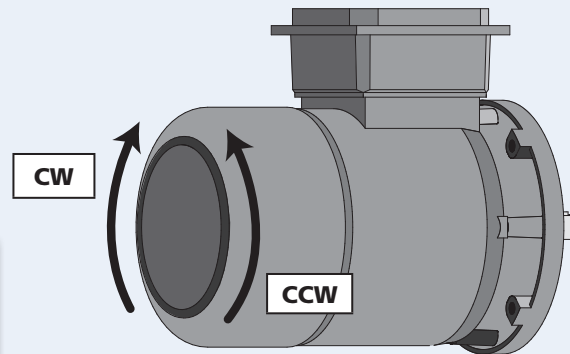

The allowable direction of rotation must be specified in the order.

### Allowable Shaft Rotation

- Clockwise - Back of Motor
- Counter Clockwise - Back of Motor

Motor Size	Backstop Torque [lb-in]	Minimum Speed [rpm]	Motor Extension [in]
80S/L/LH/LP	1150	860	2.52
90S/L/SH/LH/SP/LP	1150	860	2.95
100L/LH/LP	1150	860	3.58
112M/MH/MP	3270	750	3.66
132S/M/SH/MH/SP/LP	3270	750	4.21
160M/L/MH/LH/MP/LP	7880	670	6.57

For all motor dimensions please see pages 192 - 198.







**Quick Power Plug Connector (MS)**

Mod

The quick power plug connector (MS) is a simple and fast way to connect and disconnect a motor or brake motor. The MS connector is available on NORD three-phase motors from frame size 63 to 132. The motor connections are made by a modular power plug manufacturer by Harting. After the first installation, the motor can be quickly changed by simply plugging and unplugging the electrical connections. This will ensure the new motor is properly wired. This is a significant advantage to equipment builders who fabricate machinery on site and then ship to another location. The motor with the MS connector can simply be plugged in during final installation.

NORD supplies the male connector half mounted on the motor conduit box. The customer must supply the female connector half mounted on the power wiring. NORD supplies a protective plastic cover on the motor male connector half to protect from dirt and damage prior to installation.

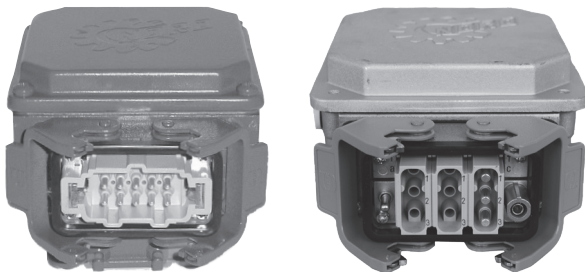

**Advantages:**

- Simple motor wiring
- Accurate wiring of motor at final job site
- Fast motor replacement
- Accurate wiring of replacement motor
- Ideal for portable equipment
- Reduces the required personnel for motor replacement
- Faster motor changes reduce down time

**Plug ratings:**

Manufacturer	Harting	
Connector	HAN 10 ES/HAN 10ESS	HAN 10 C-Modular Cage Clamp Connectors
Number of Pins	10-Male	9-Male
Voltage	600VAC per UL/CSA	690VAC per UL/CSA
Current	16A - Continuous	40A - Continuous

**Quick Power Plug Kits:**

Includes conduit box, mounting hardware & Male Harting Motor Plug

P/N	Motor size
11035350	63 + 71
13035350	80 + 90 + 100
16035350	112
16335350	132

**Power Plug Positions**

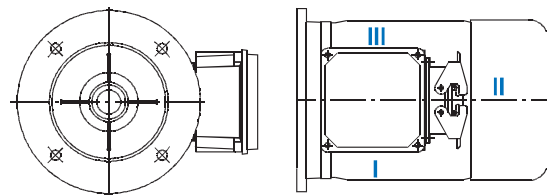

**Power plug position must be specified**

**Power Plug Position**

I     II     III

Mod

**Small Terminal Box (EKK)**

The motor terminal box can be provided as a smaller, one-piece terminal design. This option is valid for standard motors 0.16 - 10 hp (frame size 63-132) and is not available for Brakemotors.

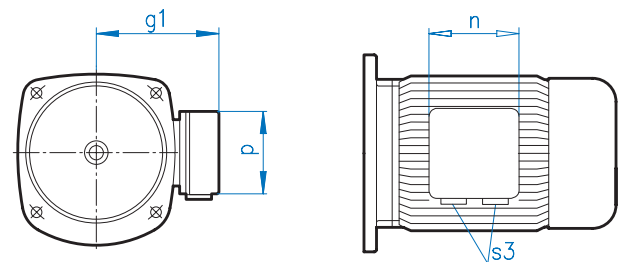

EKK Dimensions				
Motor Frame	g1	n	p	S3
63	3.94	2.95	2.95	2x M16 x 1.5
71	4.29	2.95	2.95	2x M16 x 1.5
80	4.88	3.62	3.62	2x M20 x 1.5
90	5.08	3.62	3.62	2x M20 x 1.5
100	5.51	3.62	3.62	2x M20 x 1.5
112	5.91	3.62	3.62	2x M20 x 1.5
132	6.85	4.13	4.13	2x M25 x 1.5



# AC Vector Drive Related Options



## Blower Cooling Fan (F & FC)

Mod

NORD offers continuous running motor mounted cooling fans that provide motor cooling at low motor speeds. When a motor is operated on an AC vector drive at low frequency, standard rotor fans do not provide adequate airflow for cooling. NORD's separate powered motor cooling fans provide that necessary airflow. These separately powered fans replace the standard motor fan and its cover.

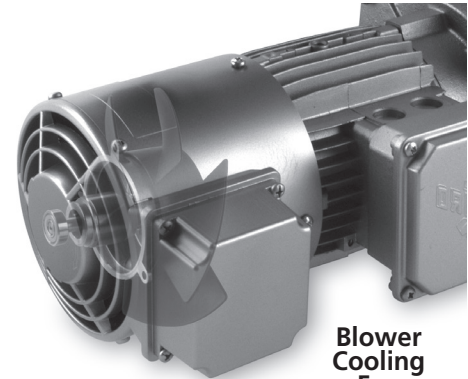

Blower Cooling Fan

### Option F – 3ph 220-575V 50/60Hz

Motor Frame	SE	EE	PE	60Hz Ratings			50Hz Ratings		
				Voltage [V]	Current [A]	Power [W]	Voltage [V]	Current [A]	Power [W]
Three phase low-voltage connection - Δ (Delta)									
63	S/L			220 – 332	0.08	23	220 – 290	0.10	27
71	S/L			220 – 332	0.08	24	220 – 290	0.10	30
80	S/L	SH/LH	LP	220 – 332	0.08	25	220 – 290	0.10	29
90	S/L	SH/LH	SP/LP	220 – 332	0.21	64	220 – 290	0.28	86
100	L/LA	LH/AH	LP/AP	220 – 332	0.21	66	220 – 290	0.27	86
112	M	SH/MH/LH	MP	220 – 332	0.23	70	220 – 290	0.27	85
132	S/M/LA	SH/MH	SP/MP	220 – 332	0.25	74	220 – 290	0.32	96
Three phase high-voltage connection - Y									
63	S/L			380 – 575	0.04	23	380 – 500	0.05	29
71	S/L			380 – 575	0.04	25	380 – 500	0.05	30
80	S/L	SH/LH	LP	380 – 575	0.04	26	380 – 500	0.05	29
90	S/L	SH/LH	SP/LP	380 – 575	0.12	62	380 – 500	0.16	82
100	L/LA	LH/AH	LP/AP	380 – 575	0.12	66	380 – 500	0.16	83
112	M	SH/MH/LH	MP	380 – 575	0.13	70	380 – 500	0.16	82
132	S/M/LA	SH/MH	SP/MP	380 – 575	0.14	75	380 – 500	0.18	96

### Option F – 1ph 220-575V 50/60Hz

Motor Frame	SE	EE	PE	60Hz Ratings			50Hz Ratings		
				Voltage [V]	Current [A]	Power [W]	Voltage [V]	Current [A]	Power [W]
Single phase connection - Δ (Delta)									
63	S/L			230 – 277	0.11	38	230 – 277	0.1	27
71	S/L			230 – 277	0.12	41	230 – 277	0.1	28
80	S/L	SH/LH	LP	230 – 277	0.13	44	230 – 277	0.11	29
90	S/L	SH/LH	SP/LP	230 – 277	0.25	88	230 – 277	0.26	72
100	L/LA	LH/AH	LP/AP	230 – 277	0.28	88	230 – 277	0.26	70
112	M	SH/MH/LH	MP	230 – 277	0.31	107	230 – 277	0.26	73
132	S/M/LA	SH/MH	SP/MP	230 – 277	0.27	89	230 – 277	0.29	82

### Option FC – 1ph 115V 50/60Hz

Motor Frame	SE	EE	PE	60Hz Ratings			50Hz Ratings		
				Voltage [V]	Current [A]	Power [W]	Voltage [V]	Current [A]	Power [W]
Single Phase Connection - Δ (Delta)									
63	S/L			100 – 135	0.23	42	100 – 135	0.3	42
71	S/L			100 – 135	0.23	47	100 – 135	0.3	44
80	S/L	SH/LH	LP	100 – 135	0.27	57	100 – 135	0.3	43
90	S/L	SH/LH	SP/LP	100 – 135	0.46	102	100 – 135	0.57	78
100	L/LA	LH/AH	LP/AP	100 – 135	0.53	105	100 – 135	0.54	78
112	M	SH/MH/LH	MP	100 – 135	0.6	115	100 – 135	0.55	80



## Encoder Overview



In many of today's drive applications encoders are needed when it necessary to monitor travel distance, position, or speed. Encoders use integrated electronics to convert sensor detected signals into a digital output format that is easily interfaced with programmable logic controllers (PLC's) and computers.

NORD offers a variety of encoder solutions that will satisfy almost any application. NORD will also work closely with our customers to satisfy many specific encoder requirements or meet specifications for a variety of protocols.

### Incremental Encoders

Incremental encoders can be used to monitor position or speed. Position is determined by counting pulses from a zero mark or home position. Speed or velocity data is generated by looking at the time interval between pulses or the number of pulses within a given time period

With incremental encoders it is necessary to re-initialize the system and return the system to the home position in the event of a power loss.

The following pages are an explanation of the types of incremental encoders that NORD offers.

## Magnetic Encoders vs. Optical Encoders

Magnetic Encoders use a magnetized wheel spinning in relationship to a fixed magneto-resistive sensor. The wheel causes predictable responses in the sensor, based on the strength of the magnetic field.

Optical Encoders use a spinning disk and a mask. The mask lets light pass through in predictable patterns for interpretation by a photo-electric sensor. In both cases the sensor produces a digital output format that is easily interfaced by the PLC or computer.

- Magnetic Incremental Encoder (Page 162)
- Optical Incremental Encoders (Page 163).

## Types of Common Pulse Signals

Incremental encoders can provide different pulse signals for each full rotation of the encoder.

**Quadrature pulse signals** are represented by two encoder output signals (A & B channel) phased 90° electrically apart; these signals help determine direction of rotation by monitoring the phase relationship between the two channels.

**Differential signals** are complimentary or mirror image [high (A & B) and low (A & B)] output signals that are generated in order to greatly reduce the encoder's susceptibility to electrical interference or noise. When noise occurs during a given pulse, a mirror image does not result and that small portion of the total signal can be ignored.

**A Marker Pulse or Index signal** (Z channel) can be provided as one pulse per revolution signal for pulse count verification on the A and/or B channels. This pulse is sometimes used for error detection or re-homing the system after a power failure or fault condition.

## Absolute Encoders

Absolute encoders use a disc system with digital coding on concentric tracks. A unique pattern is assigned to every position. True position verification and reference to home is maintained offering optimal recovery from system and/or power failures. Absolute encoder's also come in a variety of output protocols or interfaces. Additional incremental tracks are often specified to provide speed control along with accurate position monitoring.

- Absolute Encoders (Page 164).
- Absolute Encoders for NORD Vector Drives (Page 165).





## Magnetic-Incremental Encoder (MG)

NORD offers a competitively priced magnetic encoder that is easily adaptable to the 63 to 180 frame NORD motors. The magnetic encoder utilizes a special screw installed to the motor's rotor shaft in order to create a permanent rotating magnetic field.

A small 0.78 inch (20 mm) sensor pick-up is mounted to the back of the motor fan shroud. The sensor converts the changing magnetic fields into HTL, push-pull output signals that can be read by a PLC or computer. Quadrature (2 channels, A and B) output signals are phased electrically apart by 90° in order to help determine the direction of rotation by monitoring the phase relationship between the two channels. Our design enables the encoder's implementation near the vicinity of our electric brakes.

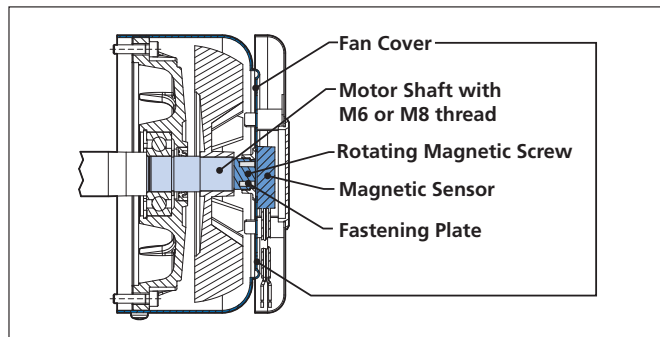

### Advantages

- Cost effective, compact, and easy to mount (63– 180 frame motors).
- Minimal dimensional change to back of motor (page 192).
- Non-contacting measuring method using magnetics.
- Accurate resolution, vibration and shock resistency in order to increase durability.

Technical Data	
Interface	HTL (push-pull) / Quadrature
Supply Voltage	10-30 VDC
Current	40 mA Max / < 30 mA (no load)
Pulse Count	1 PPR, 32 PPR or 512 PPR
Speed Range	0-5000 rpm
Protection Class	IP 68
Temp.	-4 to 212°F (-20 to 100°C)

Wire Color	Designation
Red	(+) Supply Voltage
Black	(-) Supply Voltage
Brown	Channel A
Orange	Channel B
Cable Size	ø0.19 in x 39 in Lg
Wires	4 x ø0.013 in <sup>2</sup>
Gauge	22 AWG

Pulse Count	Connection Options (Supplier)
01 = 1 PPR	O = Open-end cable
20 = 32 PPR	M = M12 motor terminal box plug (Lumberg Automation P/N R5FM4/0.5M)
50 = 512 PPR	N = M12 male plug connector (Lumberg Automation P/N RSC4/9)
	V = Coupling connector (Phoenix Contact, Quickon P/N 1641879)

Connector Wiring				
M12 Connectors (Option M or N)		Coupling Connector (Option V)		
Pin	Wire Color	Pin	Wire Color	Designation
1	Brown	1	Red	(+) Supply Voltage
2	White	2	Brown	Channel A
3	Blue	3	Orange	Channel B
4	Black	4	Black	(-) Supply Voltage

### Ordering Example

Encoder Type: MG - Pulse Count - Option

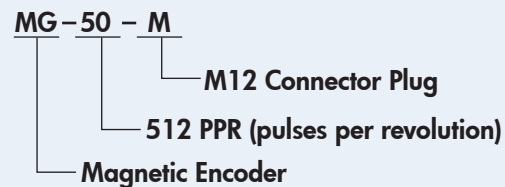

A Magnetic HTL encoder, with a 256 pulse count that is connected by a M12 connector



## Optical-Incremental Encoder (IG..P) Build

NORD offers optical incremental encoders to monitor position or speed. These encoders are typically mounted to the back side of the electric motor shaft. Common interface logic types include: TTL, HTL and Line Driver. NORD will also work closely with our customers to provide specified encoder pulse counts or control logic.

Optical incremental encoders pass light from a light emitting diode (LED) through a partially masked rotating code disc onto a photo-electric receiver. The receiver converts light pulse signals into a square wave digital output format that is easily interfaced by programmable logic controllers (PLC's) and computers.

With optical incremental encoders it is necessary to re-initialize the system and return the system to the home position in the event of power loss.

### Advantages

- Quadrature, differential and marker pulse output signals
- Accurate resolution up to 5000 ppr.
- Sturdy double bearing design offers high tolerance to shock and vibration.
- Short-circuit proof outputs and reverse connection protection.
- M12 (8-pin) male plug fixed to motor fan cover for easy wiring and adaptability.

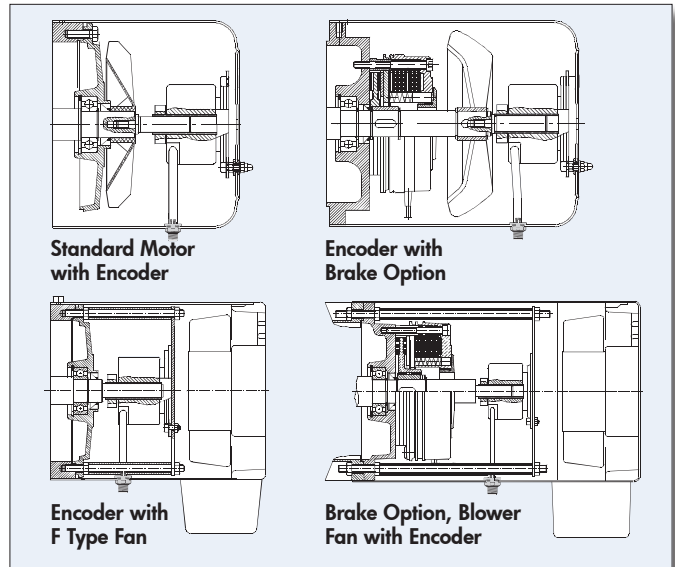

M12 Connector	Pin	Color	Signal
	1	0V	WH
	2	+V	BN
	3	A	GN
	4	A\<	YE
	5	B	GY
	6	B\<	PK
	7	Z	BU
	8	Z\<	RD

NORD Type	IG1 P	IG2 P	IG4 P	IG11 P	IG21 P	IG41 P	IG12 P	IG22 P	IG42 P	IG13 P	IG23 P	IG43 P
Part Number	19551500	19551510	19551520	19551502	19551512	19551522	19551501	19551511	19551521	19551503	19551513	19551523
Interface	TTL/RS422 (26C31)			TTL/RS422 (26C31)			HTL/Push-pull (IC-WE)			Line Driver (7272)		
Logic [VDC]	5			5			10-30			5-30		
Pulse Count [PPR]	1024	2048	4096	1024	2048	4096	1024	2048	4096	1024	2048	4096
Power Supply [VDC]	4-6	4-6	4-6	10-30	10-30	10-30	10-30	10-30	10-30	5-30	5-30	5-30
Max Current Draw [mA]	100						150					
Max Frequency [kHz]	300											
Temperature Range	-4°F to 176°F (-20°C to 80°C)											
IP Rating	IP66											
Cable	M12 8-pin male plug											

### Pre-fabricated Encoder Cables

NORD can provide Turck pre-fabricated encoder molded cordsets (M12, 8-pin, shielded, twisted pair)



Length	In-line		Right-angle	
	NORD P/N	Turck P/N	NORD P/N	Turck P/N
2m	19551580	E-RKC 8T-264-2	19551584	E-WKC 8T-264-2
5m	19551581	E-RKC 8T-264-5	19551585	E-WKC 8T-264-5
10m	19551582	E-RKC 8T-264-10	19551586	E-WKC 8T-264-10
15m	19551583	E-RKC 8T-264-15	19551587	E-WKC 8T-264-15
Field Wireable Connector	19551588	CMB 8181-0	-	-
Custom	order from Turck	E-RKC 8T-264-*	order from Turck	E-WKC 8T-264-*

- The above encoder cables are provided with the shielding NOT connected thru the plug nut
- Providing a conducting path thru the cable nut and attaching the shield to ground on both ends of the cable is a possible source of electrical noise







## Absolute Encoder (AG)

Absolute encoders do not lose position or home-position reference when power is removed. Absolute encoders provide a higher degree of safety than when using incremental encoders in applications where a loss of position could result in damage to the machinery or injury to the operator.

NORD absolute encoders are available with different data protocols or interfaces and many cases they can also be supplied with optional incremental tracks to provide accurate position and speed sensing feedback. We will also work closely with our customers to meet the specifications of the equipment builder or systems integrator.

NORD typically provides multi-turn absolute encoders mounted to the back side of the electric motor shaft. Multi-turn encoders provide turns counting in applications involving more than one revolution of the encoder shaft. Single-turn encoders can also be supplied and they are best suited for short travel, motion control applications where position verification is required within a single turn of the encoder shaft.

## Turck Absolute Encoders (AG)

Turck Type	T8.F3683	T8.F3668	T8.5860	T8.5883
Interface	SSI or BiSS-C <sup>®</sup> ②	CANopen <sup>®</sup> ②	DeviceNet™ ①	SSI or BiSS-C <sup>®</sup>
Supply Voltage	5 VDC or 10-30 VDC	10-30 VDC	10-30 VDC	5 VDC or 10-30 VDC
Single-turn Resolution	10, 12-14 & 17 bit	13 bit (default) 16 bit (max.)	13 bit	10-14 & 17 bit
Multi-turn Resolution	12, 16 or 24 bit	12 bit	12 bit	12 bit
Incremental Options	TTL/RS 422 (2048 PPR) or SinCos (2048 PPR)	None	None	TTL/RS 422 (2048 PPR) or SinCos (2048 PPR)
Shaft Version	Ø 8 mm hollow shaft	Ø 8 x 14.5 mm blind hollow shaft	Ø 12 x 30 mm blind hollow shaft	Ø 12 mm hollow shaft
Temperature Range	-40 to +194 °F (-40 to +90 °C)	-40 to +185 °F (-40 to +85 °C)	-4 to +176 °F (-20 to +80 °C)	-22 to +167 °F (-30 to +75 °C)
IP Rating	IP 67	IP 67	IP 67	IP 67

Turck Type	T8.5888	T8.5888	T8.5888	T8.5888
Interface	CANopen <sup>®</sup> ② & ③	EtherCAT <sup>®</sup>	PROFIBUS <sup>®</sup> ④	PROFINET <sup>®</sup>
Supply Voltage	10-30 VDC	10-30 VDC	10-30 VDC	10-30 VDC
Single-turn Resolution	13 bit (default) 16 bit (max.)	13 bit (default) 16 bit (max.)	13 bit (default) 16 bit (max.)	13 bit (default) 16 bit (max.)
Multi-turn Resolution	12 bit	12 bit	12 bit	12 bit
Incremental Options	TTL/RS 422 (2048 PPR)	None	None	None
Shaft Version	Ø 12 mm hollow shaft	Ø 12 x 30 mm blind hollow shaft	Ø 12 x 30 mm blind hollow shaft	Ø 12 x 30 mm blind hollow shaft
Temperature Range	-22 to +167 °F (-30 to +75 °C)	-40 to +176 °F (-40 to +80 °C)	-40 to +176 °F (-40 to +80 °C)	-40 to +185 °F (-40 to +85 °C)
IP Rating	IP 67	IP67	IP67	IP67

① DeviceNet™ encoders are subject to magnet interference due to the hall-effect sensors used.

② Device specific CANopen<sup>®</sup> profile DS406 V3.2 is also available.

③ CANopen<sup>®</sup> Lift<sup>®</sup> profile DS417 V1.1 is also available.

④ Linedriver / RS485 is functionally integrated.

BiSS<sup>®</sup> is a registered trademark of iC-Haus GmbH.

CANopen<sup>®</sup> is a registered trademark of the Controller Area Network (CAN) automation user's group.

CANopen<sup>®</sup> Lift<sup>®</sup> is copyright protected by the CAN in Automation (CiA) users group that specified the CANopen<sup>®</sup> application profile.

DeviceNet™ is a trademark of the Open DeviceNet Vendor Association, Inc. (ODVA).

EtherCAT<sup>®</sup> is a registered trademark of the EtherCat Technology Group (donated by Beckhoff Automation GmbH).

EtherNET was a trademark of Xerox Corporation, which relinquished the trademark when it was standardized by 95 IEEE 802.3.

PROFIBUS-DP<sup>®</sup> is a registered trademark of PROFIBUS User Organization and PROFIBUS International.

PROFINET<sup>®</sup> is a registered trademark of PROFIBUS and PROFINET International (PI).





## Absolute Encoder (AG) - For AC Vector Drives

Many NORD AC variable frequency drives have an on-board CANopen® interface allowing the user to implement vector-drive position control.

The encoders listed in the table below communicate using CANopen® profile DS406 V3.2; device specific add-ons allow parameterization of the absolute encoder directly from the NORD frequency inverter.

The table indicates which encoder options contain incremental tracks so that speed control can also be monitored, which is necessary when speed control is required in addition to positive control.

Consult the appropriate NORD user manuals for frequency drive and encoder wiring. Also consult the encoder manufacturer's documentation for the encoder terminal assignments.

## Absolute Encoders (AG) - For NORD AC Variable Frequency Inverters

Turck Type (NORD P/N)	T8.5888 (19551883)	T8.5888 (19551891)	T8.5888 (19551881)	T8.5888 (19551886)
NORD AC VFD Type	SK2xxE, SK53xE	SK53xE	SK53xE	SK2xxE
Interface	CANopen® profile DS406 V3.2 ❶	CANopen® profile DS406 V3.2 ❶	CANopen® profile DS406 V3.2 ❶	CANopen® profile DS406 V3.2 ❶
Supply Voltage	10-30 VDC	10-30 VDC	10-30 VDC	10-30 VDC
Single-turn Resolution	13 bit (8192)	13 bit (8192)	13 bit (8192)	13 bit (8192)
Multi-turn Resolution	12 bit (4096)	12 bit (4096)	12 bit (4096)	12 bit (4096)
Node address/Baud rate (kbits/s)	51 / 125 ❷ (fixed/fixed)	51 / 125 ❸ (fixed/fixed)	51 / 125 ❷ (fixed/fixed)	51 / 125 ❷ (fixed/fixed)
Incremental Output	None	None	TTL/RS 422 (2048 PPR)	HTL/Push-Pull (2048 PPR)
Shaft Version	Ø 12 x 30 mm blind hollow shaft	Ø 12 x 30 mm blind hollow shaft	Ø 12 x 30 mm blind hollow shaft	Ø 12 x 30 mm blind hollow shaft
Temperature Range	-40 to +176 °F (-40 to +80 °C)	-22 to +167 °F (-30 to +75 °C)	-40 to +176 °F (-40 to +80 °C)	-40 to +176 °F (-40 to +80 °C)
IP Rating	IP 67	IP 67	IP 67	IP 67
Electrical Connection	Removable Bus Cover with Cable Glands	Fixed Connection - (2m) Radial Cable	3 x M12 Connectors (Bus-in, TTL, Bus-out)	3 x M12 Connectors (Bus-in, HTL, Bus-out)



## NORD AC Vector Drive Encoder Compatibility

NORD AC Vector Drive	Turck Encoder Type (NORD P/N)			
	T8.5888 (19551883)	T8.5888 (19551891)	T8.5888 (19551881)	T8.5888 (19551886)
SK530E	✓	✓	✓	
SK200E	✓ ❹			✓
SK210E	✓ ❹			✓
SK220E	✓ ❹			✓
SK230E	✓ ❹			✓
SK205E	✓			✓
SK215E	✓			✓
SK225E	✓			✓
SK235E	✓			✓

- ❶ CANopen® profile DS406 V3.2 contains device specific add-ons to work with NORD AC Variable Frequency Drives
- ❷ Device specific CANopen® profile DS406 V3.2 is also available.
- ❸ CANopen® Lift® profile DS417 V1.1 is also available.
- ❹ Linedriver / RS485 is functionally integrated.

CANopen® is a registered trademark of the Controller Area Network (CAN) automation user's group



## Motor Ratings

- 60Hz 230/460V Standard Eff.
- 60Hz 230/460V Energy Eff.
- 60Hz 230/460V Premium Eff.
- 60Hz 575V Standard Eff.
- 60Hz 575V Energy Eff.
- 60Hz 575V Premium Eff.
- 60Hz 200/208V Standard Eff.
- 50Hz 400 Standard Eff.
- 50Hz 230/400V & 400/690V Energy Eff.
- 50Hz 230/400V & 400/690V Premium Eff.
- Energy Efficiency Regulations
- Motor Efficiency Ratings

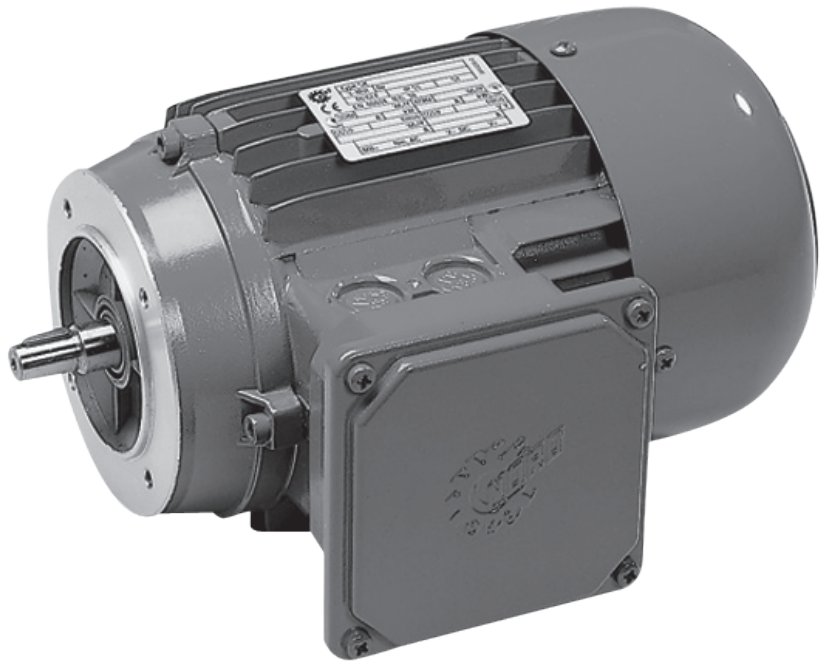

Motor Type	Power P <sub>n</sub>		n <sub>n</sub> Full-load [rpm]	In Full-Load Current	
	[hp]	[kW]		230V <sup>a)</sup> [A]	460V <sup>b)</sup> [A]
63S/4	0.16	0.12	1700	0.88	0.44
63L/4	0.25	0.18	1680	1.12	0.56
71S/4	0.33	0.25	1710	1.56	0.78
71L/4	0.5	0.37	1720	1.90	0.95
80S/4	0.75	0.55	1710	2.70	1.35
80L/4	1	0.75	1650	3.66	1.83
90S/4	1.5	1.1	1660	4.84	2.42
90L/4	2	1.5	1660	6.34	3.17
100L/4	3	2.2	1705	9.0	4.50
100LA/4	5	3.7	1725	15.2	7.62
132S/4	7.5	5.5	1735	19.8	9.9
132M/4	10	7.5	1735	25.8	12.9
160M/4	15	11	1770	38.4	19.2



# Performance Data



## Standard Efficiency

## 230/460V – 60Hz

Inverter duty • TEFC  
 Synchronous speed 1800rpm @ 60Hz • 4-pole • Three-phase  
 Voltages: 230/460V – 60Hz • 1.15 Service Factor  
 Continuous Duty • 40°C Ambient • up to 3300ft Elevation  
 Class B temperature rise • Class F insulation



Motor Type	Power P <sub>n</sub>		N <sub>n</sub> Full-load [rpm]	I <sub>n</sub> Full-Load Current		I <sub>a</sub> /I <sub>n</sub> [%]	Code Letter	Torque T <sub>n</sub> [lb-in]	T <sub>a</sub> /T <sub>n</sub>	T <sub>k</sub> /T <sub>n</sub>	pf	Eff. [%]	J <sub>m</sub> Inertia [lb-ft <sup>2</sup> ]
	[hp]	[kW]		230V [A]	460V [A]								
63 S/4	0.16	0.12	1700	0.88	0.44	250	F	5.9	2.7	3.5	0.66	52.0	0.0050
63 L/4	0.25	0.18	1680	1.12	0.56	270	E	9.4	2.3	2.5	0.71	57.0	0.0066
71 S/4	0.33	0.25	1710	1.56	0.78	310	G	12.2	2.4	2.7	0.64	63.0	0.015
71 L/4	0.5	0.37	1720	1.90	0.95	350	F	18.3	2.3	2.7	0.69	71.0	0.018
80 S/4	0.75	0.55	1710	2.70	1.35	350	F	27.6	2.2	2.3	0.71	72.0	0.030
80 L/4	1	0.75	1650	3.66	1.83	390	G	38.2	2.2	2.3	0.74	70.0	0.039
90 S/4	1.5	1.1	1660	4.84	2.42	490	G	57.0	2.5	2.8	0.78	73.0	0.056
90 L/4	2	1.5	1660	6.34	3.17	510	G	75.9	2.5	2.8	0.80	74.0	0.074
100 L/4	3	2.2	1705	9.00	4.50	490	G	111	2.3	2.6	0.81	76.0	0.107
100 LA/4	5	3.7	1725	15.2	7.62	510	G	183	2.7	3.1	0.75	81.0	0.178
132 S/4	7.5	5.5	1735	19.8	9.90	540	G	272	2.4	2.7	0.82	85.0	0.553
132 M/4	10	7.5	1735	25.8	12.9	630	H	363	2.9	3.2	0.84	87.0	0.752

- |                                |   |                                |                                |   |                           |
|--------------------------------|---|--------------------------------|--------------------------------|---|---------------------------|
| P <sub>n</sub>                 | - | Full load power                | T <sub>a</sub> /T <sub>n</sub> | - | Locked-rotor torque ratio |
| N <sub>n</sub>                 | - | Full load speed                | T <sub>k</sub>                 | - | Break-down torque         |
| I <sub>n</sub>                 | - | Full load current              | T <sub>k</sub> /T <sub>n</sub> | - | Break-down torque ratio   |
| I <sub>a</sub>                 | - | Locked-rotor current           | pf                             | - | Power factor              |
| I <sub>a</sub> /I <sub>n</sub> | - | Locked-rotor current ratio (%) | Eff                            | - | Normal efficiency         |
| T <sub>n</sub>                 | - | Full-load torque               | J <sub>m</sub>                 | - | Motor inertia             |
| T <sub>a</sub>                 | - | Locked-rotor torque            |                                |   |                           |



## Energy Efficient (EPAAct)

## 230/460V – 60Hz / EE

Inverter duty • TEFC  
 Synchronous speed 1800rpm @ 60Hz • 4-pole • Three-phase  
 Voltages: 230/460V – 60Hz • 1.15 Service Factor  
 Continuous Duty • 40°C Ambient • up to 3300ft Elevation  
 Class B temperature rise • Class F insulation



Motor Type	Power P <sub>n</sub>		N <sub>n</sub> Full-load	I <sub>n</sub> Full-Load Current		I <sub>a</sub> /I <sub>n</sub>	Code Letter	Torque T <sub>n</sub>	T <sub>a</sub> /T <sub>n</sub>	T <sub>k</sub> /T <sub>n</sub>	pf	Eff.	J <sub>m</sub> Inertia
	[hp]	[kW]		[rpm]	230V [A]								
80 LH/4	1	0.75	1750	3.88	1.94	600	K	36.0	4.6	4.3	0.59	82.5	0.045
90 SH/4	1.5	1.1	1740	4.30	2.15	630	L	54.3	3.5	3.8	0.76	84.0	0.081
90 LH/4	2	1.5	1745	6.30	3.15	670	K	72.2	4.3	4.5	0.71	84.0	0.093
100 LH/4	3	2.2	1765	8.60	4.30	790	L	107	3.6	4.7	0.73	87.5	0.178
112 MH/4	5	3	1770	14.4	7.20	810	L	178	4.0	4.8	0.74	87.5	0.304
132 SH/4	7.5	5.5	1780	20.9	10.5	820	M	266	4.3	4.6	0.74	89.5	0.752
132 MH/4	10	7.5	1770	27.0	13.5	740	M	356	3.2	4.0	0.78	89.5	0.840

- |                                |   |                                |                                |   |                           |
|--------------------------------|---|--------------------------------|--------------------------------|---|---------------------------|
| P <sub>n</sub>                 | - | Full load power                | T <sub>a</sub> /T <sub>n</sub> | - | Locked-rotor torque ratio |
| N <sub>n</sub>                 | - | Full load speed                | T <sub>k</sub>                 | - | Break-down torque         |
| I <sub>n</sub>                 | - | Full load current              | T <sub>k</sub> /T <sub>n</sub> | - | Break-down torque ratio   |
| I <sub>a</sub>                 | - | Locked-rotor current           | pf                             | - | Power factor              |
| I <sub>a</sub> /I <sub>n</sub> | - | Locked-rotor current ratio (%) | Eff                            | - | Normal efficiency         |
| T <sub>n</sub>                 | - | Full-load torque               | J <sub>m</sub>                 | - | Motor inertia             |
| T <sub>a</sub>                 | - | Locked-rotor torque            |                                |   |                           |



# Performance Data



## Premium Efficient (EISA)

## 230/460V – 60Hz / PE

Inverter duty • TEFC  
 Synchronous speed 1800rpm @ 60Hz • 4-pole • Three-phase  
 Voltages: 230/460V – 60Hz • 1.15 Service Factor  
 Continuous Duty • 40°C Ambient • up to 3300ft Elevation  
 Class B temperature rise • Class F insulation



Motor Type	Power P <sub>n</sub>		N <sub>n</sub> Full-load [rpm]	I <sub>n</sub> Full-Load Current		I <sub>a</sub> /I <sub>n</sub> [%]	Code Letter	Torque T <sub>n</sub> [lb-in]	T <sub>a</sub> /T <sub>n</sub>	T <sub>k</sub> /T <sub>n</sub>	pf	Eff. [%]	J <sub>m</sub> Inertia [lb-ft <sup>2</sup> ]
	[hp]	[kW]		230V [A]	460V [A]								
80 LP/4	1	7.5	1730	3.14	1.57	650	L	36.4	3.4	3.8	0.70	86.1	0.045
90 SP/4	1.5	1.1	1740	4.20	2.10	840	J	54.3	4.1	4.9	0.76	86.9	0.081
90 LP/4	2	1.5	1730	5.60	2.80	760	K	72.9	3.8	4.2	0.78	87.0	0.093
100 LP/4	3	2.2	1770	7.70	3.84	920	L	107	3.0	4.5	0.79	90.0	0.192
112 MP/4	5	3.7	1755	13.0	6.50	910	L	180	3.8	4.3	0.80	90.3	0.332
132 SP/4	7.5	5.5	1770	19.5	9.80	1020	L	267	4.7	5.0	0.77	91.7	0.759
132 MP/4	10	7.5	1765	26.6	13.3	960	J	357	4.7	5.0	0.77	91.7	0.831

- |                                |   |                                |                                |   |                           |
|--------------------------------|---|--------------------------------|--------------------------------|---|---------------------------|
| P <sub>n</sub>                 | - | Full load power                | T <sub>a</sub> /T <sub>n</sub> | - | Locked-rotor torque ratio |
| N <sub>n</sub>                 | - | Full load speed                | T <sub>k</sub>                 | - | Break-down torque         |
| I <sub>n</sub>                 | - | Full load current              | T <sub>k</sub> /T <sub>n</sub> | - | Break-down torque ratio   |
| I <sub>a</sub>                 | - | Locked-rotor current           | pf                             | - | Power factor              |
| I <sub>a</sub> /I <sub>n</sub> | - | Locked-rotor current ratio (%) | Eff                            | - | Normal efficiency         |
| T <sub>n</sub>                 | - | Full-load torque               | J <sub>m</sub>                 | - | Motor inertia             |
| T <sub>a</sub>                 | - | Locked-rotor torque            |                                |   |                           |







## Standard Efficiency

## 575V – 60Hz

Inverter duty • TEFC  
 Synchronous speed 1800rpm @ 60Hz • 4-pole • Three-phase  
 Voltages: 332/575V – 60Hz • 1.15 Service Factor  
 Continuous Duty • 40°C Ambient • up to 3300ft Elevation  
 Class B temperature rise • Class F insulation



Motor Type	Power P <sub>n</sub>		N <sub>n</sub> Full-load [rpm]	I <sub>n</sub> Full-Load Current 575V [A]	I <sub>a</sub> /I <sub>n</sub> [%]	Code Letter	Torque T <sub>n</sub> [lb-in]	T <sub>a</sub> /T <sub>n</sub>	T <sub>k</sub> /T <sub>n</sub>	pf	Eff. [%]	J <sub>m</sub> Inertia [lb-ft <sup>2</sup> ]
	[hp]	[kW]										
63 S/4	0.16	0.12	1700	0.37	250	F	5.9	2.7	3.5	0.66	52.0	0.0050
63 L/4	0.25	0.18	1680	0.46	270	E	9.4	2.3	2.5	0.71	57.0	0.0066
71 S/4	0.33	0.25	1710	0.66	310	G	12.2	2.4	2.7	0.64	63.0	0.015
71 L/4	0.5	0.37	1720	0.80	350	F	18.3	2.3	2.7	0.69	71.0	0.018
80 S/4	0.75	0.55	1710	1.12	350	F	27.6	2.2	2.3	0.71	72.0	0.030
80 L/4	1	0.75	1650	1.46	390	G	38.2	2.2	2.3	0.74	70.0	0.039
90 S/4	1.5	1.1	1660	1.94	490	G	57.0	2.5	2.8	0.78	73.0	0.056
90 L/4	2	1.5	1660	2.54	510	G	75.9	2.5	2.8	0.80	74.0	0.074
100 L/4	3	2.2	1705	3.63	490	G	111	2.3	2.6	0.81	76.0	0.107
100 LA/4	5	3.7	1725	6.10	510	G	183	2.7	3.1	0.75	81.0	0.178
132 S/4	7.5	5.5	1735	7.92	540	G	272	2.4	2.7	0.82	85.0	0.553
132 M/4	10	7.5	1735	10.3	630	H	363	2.9	3.2	0.84	87.0	0.752

P <sub>n</sub>	-	Full load power	T <sub>a</sub> /T <sub>n</sub>	-	Locked-rotor torque ratio
N <sub>n</sub>	-	Full load speed	T <sub>k</sub>	-	Break-down torque
I <sub>n</sub>	-	Full load current	T <sub>k</sub> /T <sub>n</sub>	-	Break-down torque ratio
I <sub>a</sub>	-	Locked-rotor current	pf	-	Power factor
I <sub>a</sub> /I <sub>n</sub>	-	Locked-rotor current ratio (%)	Eff	-	Normal efficiency
T <sub>n</sub>	-	Full-load torque	J <sub>m</sub>	-	Motor inertia
T <sub>a</sub>	-	Locked-rotor torque			



# Performance Data



## Energy Efficient (EPAAct)

## 575V – 60Hz / EE

Inverter duty • TEFC  
 Synchronous speed 1800rpm @ 60Hz • 4-pole • Three-phase  
 Voltages: 332/575V – 60Hz • 1.15 Service Factor  
 Continuous Duty • 40°C Ambient • up to 3300ft Elevation  
 Class B temperature rise • Class F insulation



Motor Type	Power P <sub>n</sub>		N <sub>n</sub> Full-load [rpm]	I <sub>n</sub> Full-Load Current 575V [A]	I <sub>a</sub> /I <sub>n</sub> [%]	Code Letter	Torque T <sub>n</sub> [lb-in]	T <sub>a</sub> /T <sub>n</sub>	T <sub>k</sub> /T <sub>n</sub>	pf	Eff. [%]	J <sub>m</sub> Inertia [lb-ft <sup>2</sup> ]
	[hp]	[kW]										
80 LH/4	1	0.75	1750	1.50	600	K	36.0	4.6	4.3	0.59	82.5	0.045
90 SH/4	1.5	1.1	1740	1.75	630	L	54.3	3.5	3.8	0.76	84.0	0.081
90 LH/4	2	1.5	1745	2.45	670	K	72.2	4.3	4.5	0.71	84.0	0.093
100 LH/4	3	2.2	1765	3.40	790	L	107	3.6	4.7	0.73	87.5	0.178
112 MH/4	5	3	1770	5.60	810	L	178	4.0	4.8	0.74	87.5	0.304
132 SH/4	7.5	5.5	1780	8.30	820	M	266	4.3	4.6	0.74	89.5	0.752
132 MH/4	10	7.5	1770	10.8	740	M	356	3.2	4.0	0.78	89.5	0.840

- |                                |   |                                |                                |   |                           |
|--------------------------------|---|--------------------------------|--------------------------------|---|---------------------------|
| P <sub>n</sub>                 | - | Full load power                | T <sub>a</sub> /T <sub>n</sub> | - | Locked-rotor torque ratio |
| N <sub>n</sub>                 | - | Full load speed                | T <sub>k</sub>                 | - | Break-down torque         |
| I <sub>n</sub>                 | - | Full load current              | T <sub>k</sub> /T <sub>n</sub> | - | Break-down torque ratio   |
| I <sub>a</sub>                 | - | Locked-rotor current           | pf                             | - | Power factor              |
| I <sub>a</sub> /I <sub>n</sub> | - | Locked-rotor current ratio (%) | Eff                            | - | Normal efficiency         |
| T <sub>n</sub>                 | - | Full-load torque               | J <sub>m</sub>                 | - | Motor inertia             |
| T <sub>a</sub>                 | - | Locked-rotor torque            |                                |   |                           |





## Premium Efficient (EISA)

## 575V – 60Hz / PE

Inverter duty • TEFC  
 Synchronous speed 1800rpm @ 60Hz • 4-pole • Three-phase  
 Voltages: 332/575V – 60Hz • 1.15 Service Factor  
 Continuous Duty • 40°C Ambient • up to 3300ft Elevation  
 Class B temperature rise • Class F insulation



Motor Type	Power P <sub>n</sub>		N <sub>n</sub> Full Load [rpm]	I <sub>n</sub> Full-Load Current 575V [A]	I <sub>a</sub> /I <sub>n</sub> [%]	Code Letter	Torque T <sub>n</sub> [lb-in]	T <sub>a</sub> /T <sub>n</sub>	T <sub>k</sub> /T <sub>n</sub>	pf	Eff. [%]	J <sub>m</sub> Inertia [lb-ft <sup>2</sup> ]
	[hp]	[kW]										
80 LP/4	1	0.75	1730	1.30	650	L	36.4	3.4	3.8	0.70	86.1	0.045
90 SP/4	1.5	1.1	1740	1.68	840	J	54.3	4.1	4.9	0.76	86.9	0.081
90 LP/4	2	1.5	1730	2.24	760	K	72.9	3.8	4.2	0.78	87.0	0.093
100 LP/4	3	2.2	1770	3.07	920	L	107	3.0	4.5	0.79	90.0	0.192
112 MP/4	5	3.7	1755	5.20	910	L	180	3.8	4.3	0.80	90.3	0.332
132 SP/4	7.5	5.5	1770	7.80	1020	L	267	4.7	5.0	0.77	91.7	0.759
132 MP/4	10	7.5	1765	10.6	960	J	357	4.7	5.0	0.77	91.7	0.831

- |                                |   |                                |                                |   |                           |
|--------------------------------|---|--------------------------------|--------------------------------|---|---------------------------|
| P <sub>n</sub>                 | - | Full load power                | T <sub>a</sub> /T <sub>n</sub> | - | Locked-rotor torque ratio |
| N <sub>n</sub>                 | - | Full load speed                | T <sub>k</sub>                 | - | Break-down torque         |
| I <sub>n</sub>                 | - | Full load current              | T <sub>k</sub> /T <sub>n</sub> | - | Break-down torque ratio   |
| I <sub>a</sub>                 | - | Locked-rotor current           | pf                             | - | Power factor              |
| I <sub>a</sub> /I <sub>n</sub> | - | Locked-rotor current ratio (%) | Eff                            | - | Normal efficiency         |
| T <sub>n</sub>                 | - | Full-load torque               | J <sub>m</sub>                 | - | Motor inertia             |
| T <sub>a</sub>                 | - | Locked-rotor torque            |                                |   |                           |



# Performance Data



## Standard Efficiency

## 200-208V – 60Hz

Inverter duty • Induction motor • TEFC  
 Synchronous speed 1800rpm @ 60Hz • 4-pole • Three-phase  
 Voltages: 208V – 60Hz • 1.15 Service Factor  
 Continuous Duty • 40°C Ambient • up to 3300ft Elevation  
 Class B temperature rise • Class F insulation



Motor Type	Power P <sub>n</sub>		N <sub>n</sub> Full-load [rpm]	I <sub>n</sub> 208V [A]	I <sub>a</sub> /I <sub>n</sub> [%]	Code Letter	Torque T <sub>n</sub> [lb-in]	T <sub>a</sub> /T <sub>n</sub>	T <sub>k</sub> /T <sub>n</sub>	pf	Eff. [%]	J <sub>m</sub> Inertia [lb-ft <sup>2</sup> ]
	[hp]	[kW]										
63S/4	0.16	0.12	1700	0.97	245	F	5.93	2.1	2.2	0.66	52	0.005
63L/4	0.25	0.18	1680	1.24	275	E	9.38	2.1	2.2	0.71	57	0.0067
71S/4	0.33	0.25	1710	1.73	310	G	12.2	2.5	2.4	0.64	63	0.015
71L/4	0.5	0.37	1720	2.10	355	F	18.3	2.45	2.6	0.69	71	0.0181
80S/4	0.75	0.55	1710	2.99	355	F	27.6	2.2	2.2	0.71	72	0.0304
80L/4	1	0.75	1650	4.05	390	G	38.2	2.2	2.3	0.74	70	0.0392
90S/4	1.5	1.1	1660	5.35	445	G	57.0	2.7	2.6	0.78	73	0.0670
90L/4	2	1.5	1660	7.01	465	G	75.9	2.55	2.5	0.80	74	0.0855
100L/4	3	2.2	1705	9.95	490	G	111	2.3	2.6	0.81	82	0.107
100LA/4	5	3.7	1725	16.8	510	G	183	2.7	3.1	0.75	81	0.162



- |                                |   |                                |                                |   |                           |
|--------------------------------|---|--------------------------------|--------------------------------|---|---------------------------|
| P <sub>n</sub>                 | - | Full load power                | T <sub>a</sub> /T <sub>n</sub> | - | Locked-rotor torque ratio |
| N <sub>n</sub>                 | - | Full load speed                | T <sub>k</sub>                 | - | Break-down torque         |
| I <sub>n</sub>                 | - | Full load current              | T <sub>k</sub> /T <sub>n</sub> | - | Break-down torque ratio   |
| I <sub>a</sub>                 | - | Locked-rotor current           | pf                             | - | Power factor              |
| I <sub>a</sub> /I <sub>n</sub> | - | Locked-rotor current ratio (%) | Eff                            | - | Normal efficiency         |
| T <sub>n</sub>                 | - | Full-load torque               | J <sub>m</sub>                 | - | Motor inertia             |
| T <sub>a</sub>                 | - | Locked-rotor torque            |                                |   |                           |



## Standard Efficiency

## 400V – 50Hz

Inverter duty • Induction motor • TEFC  
 Synchronous speed 1500rpm @ 50Hz • 4-pole • Three-phase  
 Voltages: 400V – 50Hz • 1.0 Service Factor  
 Continuous Duty • 40°C Ambient • up to 3300ft Elevation  
 Class B temperature rise • Class F insulation



Motor Type	Power $P_n$		$N_n$ Full-Load [rpm]	$I_n$ 400 V (380-420V) [A]	$I_a/I_n$ [%]	Code Letter	Torque $T_n$ [lb-in]	$T_a/T_n$	$T_k/T_n$	pf	Eff. [%]	$J_m$ Inertia [lb-ft <sup>2</sup> ]
	[hp]	[kW]										
63 S/4	0.16	0.12	1335	0.55	290	H	7.59	2.7	2.7	0.64	49.9	0.0050
63 L/4	0.25	0.18	1360	0.68	330	G	11.2	2.5	2.6	0.64	56.2	0.0066
71 S/4	0.33	0.25	1380	0.76	330	F	15.3	2.2	2.1	0.77	61.3	0.017
71 L/4	0.5	0.37	1380	1.09	360	F	22.7	2.0	2.4	0.71	64.4	0.020
80 S/4	0.75	0.55	1375	1.52	330	E	33.8	1.9	2.0	0.73	75.1	0.026
80 L/4	1	0.75	1375	2.10	350	F	46.1	2.0	2.1	0.74	75.5	0.034
90 S/4	1.5	1.1	1395	2.81	440	G	66.6	2.3	2.6	0.74	77.6	0.056
90 L/4	2	1.5	1395	3.55	480	G	90.8	2.3	2.6	0.78	77.5	0.074
100 L/4	3	2.2	1440	5.22	510	G	129	2.3	3.0	0.74	80.8	0.107
100 LA/4	4	3	1415	6.54	540	G	179	2.5	2.9	0.80	83.3	0.142
112 M/4	5.4	4	1445	8.30	530	G	234	2.3	2.8	0.80	85.1	0.261
132 S/4	7.5	5.5	1445	11.4	550	G	322	2.1	2.7	0.81	87.9	0.570
132 M/4	10	7.5	1445	14.8	550	F	438	2.5	2.8	0.84	87.7	0.759

$P_n$	-	Full load power	$T_a/T_n$	-	Locked-rotor torque ratio
$N_n$	-	Full load speed	$T_k$	-	Break-down torque
$I_n$	-	Full load current	$T_k/T_n$	-	Break-down torque ratio
$I_a$	-	Locked-rotor current	pf	-	Power factor
$I_a/I_n$	-	Locked-rotor current ratio (%)	Eff	-	Normal efficiency
$T_n$	-	Full-load torque	$J_m$	-	Motor inertia
$T_a$	-	Locked-rotor torque			



# Performance Data



## Energy Efficient (IE2)

## 400V (380-420V) – 50Hz

Inverter duty • Induction motor • TEFC  
 Synchronous speed 1500rpm @ 50Hz • 4-pole • Three-phase  
 Voltages: 400V (380-420V) – 50Hz • 1.0 Service Factor  
 Continuous Duty • 40°C Ambient • up to 3300ft Elevation  
 Class B temperature rise • Class F insulation



Motor Type	Power P <sub>n</sub>		N <sub>n</sub> Full-Load [rpm]	I <sub>n</sub> 400V (380-420V) [A]	I <sub>a</sub> /I <sub>n</sub> [%]	Code Letter	Torque T <sub>n</sub> [lb-in]	T <sub>a</sub> /T <sub>n</sub>	T <sub>k</sub> /T <sub>n</sub>	pf	Eff. [%]	J <sub>m</sub> Inertia [lb-ft <sup>2</sup> ]
	[hp]	[kW]										
80 SH/4	0.75	0.55	1,420	1.41	510	H	32.7	3.1	3.2	0.70	80.8	0.033
80 LH/4	1	0.75	1,415	1.76	520	H	44.8	3.0	3.1	0.75	82.4	0.045
90 SH/4	1.5	1.1	1,435	2.42	610	H	64.8	3.1	3.5	0.80	81.8	0.081
90 LH/4	2	1.5	1,415	3.34	580	H	89.6	3.3	3.5	0.79	82.8	0.093
100 LH/4	3	2.2	1,445	4.65	730	J	129	3.7	4.3	0.79	86.6	0.178
100 AH/4	4	3	1,425	6.59	630	J	178	3.1	3.5	0.77	85.6	0.178
112 MH/4	5.4	4	1,440	8.02	750	J	235	3.1	3.6	0.83	86.7	0.332
132 SH/4	7.5	5.5	1,460	10.7	750	J	318	3.1	3.5	0.84	88.2	0.759
132 MH/4	10	7.5	1,460	15.0	750	J	434	3.3	3.9	0.81	89.3	0.831



P <sub>n</sub>	-	Full load power	T <sub>a</sub> /T <sub>n</sub>	-	Locked-rotor torque ratio
N <sub>n</sub>	-	Full load speed	T <sub>k</sub>	-	Break-down torque
I <sub>n</sub>	-	Full load current	T <sub>k</sub> /T <sub>n</sub>	-	Break-down torque ratio
I <sub>a</sub>	-	Locked-rotor current	pf	-	Power factor
I <sub>a</sub> /I <sub>n</sub>	-	Locked-rotor current ratio (%)	Eff	-	Normal efficiency
T <sub>n</sub>	-	Full-load torque	J <sub>m</sub>	-	Motor inertia
T <sub>a</sub>	-	Locked-rotor torque			





## Premium Efficient (IE3)

## 400V (380-420V) – 50Hz

Inverter duty • Induction motor • TEFC  
 Synchronous speed 1500rpm @ 50Hz • 4-pole • Three-phase  
 Voltages: 400V (380-420V) – 50Hz • 1.10 Service Factor  
 Continuous Duty • 40°C Ambient • up to 3300ft Elevation  
 Class B temperature rise • Class F insulation



Motor Type	Power $P_n$		$N_n$ Full-Load [rpm]	$I_n$ 400V (380-420V) [A]	$I_a/I_n$ [%]	Code Letter	Torque $T_n$ [lb-in]	$T_a/T_n$	$T_k/T_n$	pf	Eff. [%]	$J_m$ Inertia [lb-ft <sup>2</sup> ]
	[hp]	[kW]										
80 LP/4	1	0.75	1,415	1.79	540	H	44.8	3.0	3.1	0.72	83.7	0.045
90 SP/4	1.5	1.1	1,430	2.38	700	J	65.0	3.6	4.0	0.78	85.3	0.081
90 LP/4	2	1.5	1,415	3.23	590	H	89.6	3.3	3.5	0.79	85.3	0.093
100 LP/4	3	2.2	1,465	4.27	820	K	127	2.6	3.9	0.83	88.1	0.192
100 AP/4	4	3	1,460	6.05	730	J	174	2.4	3.6	0.81	88.1	0.192
112 MP/4	5.4	4	1,440	7.82	750	J	235	3.4	3.6	0.83	88.6	0.332
132 SP/4	7.5	5.5	1,465	10.9	860	K	317	3.7	4.0	0.80	90.9	0.759
132 MP/4	10	7.5	1,460	15.0	820	K	434	3.9	4.2	0.80	90.9	0.831

$P_n$	-	Full load power	$T_a/T_n$	-	Locked-rotor torque ratio
$N_n$	-	Full load speed	$T_k$	-	Break-down torque
$I_n$	-	Full load current	$T_k/T_n$	-	Break-down torque ratio
$I_a$	-	Locked-rotor current	pf	-	Power factor
$I_a/I_n$	-	Locked-rotor current ratio (%)	Eff	-	Normal efficiency
$T_n$	-	Full-load torque	$J_m$	-	Motor inertia
$T_a$	-	Locked-rotor torque			





## Energy Efficiency Global Regulation

### United States

The United States has implemented amended motor efficiency regulations. This process started with the "Public Law 110-140", which had been passed through legislation on December 19, 2007, and is called the "Energy Independence and Security Act" (EISA). This legislation in most cases replaces the existing law that governed motor efficiency in the USA (Energy Policy Act or EAct). In general, EISA increases the efficiency requirements for many motors. EISA includes a "Premium Efficiency" motor class in addition to the two existing efficiency classes of motors that had been utilized. This law took effect on December 19, 2010 whereas all motors produced after that date must meet EISA requirements. Motors that had been in stock at that time are exempt and still may be sold.

The EISA law also expanded the scope of motors required to meet efficiency levels. The following classes of motors were not included in EAct but now must meet efficiency requirements per EISA:

#### Motor Types Covered in the EISA Efficiency Requirements

U-frame motors
NEMA electrical design C motors
Closed coupled pump motors
Footless motors
Vertical solid shaft thrust motors
8-pole motors
Voltages other than 230 or 460
201-500 hp motors

In this law, the US Department of Energy (DOE) has been responsible for writing the new regulation requirements. These regulations clarify how the law has been implemented and provide an increased level of detail in terms of specifics. The regulations are included in the Federal Register / Volume 74, NO. 54 / Monday, March 23, 2009 – Part 431. The regulations also indicate what style of motors must conform to each efficiency level explained.

#### Motor Classes Covered by EISA Efficiency Requirements

General Purpose Motors per NEMA MG1
1-500hp
2, 4, 6 & 8 pole
600V and below, 3-phase, 60Hz
NEMA Designs A, B, C & equivalent IEC equivalents
TEFC – Totally Enclosed Fan Cooled
ODP – Open Drip Proof
XP – Explosion Proof (ATEX)
Increased enclosure protections (Examples include Washdown, Severe duty,...)
NEMA Frames 140 and larger
IEC Frames 90 & Larger
NEMA T-frame (and U-frame) & IEC equivalents

Any of the following are exemptions from the EISA requirements:

#### Motor Classes not Covered by EISA Efficiency Requirements

Definite or Special Purpose per NEMA MG1
Integral gearmotor motors
Less than 1 hp
Multi-speed motors
Single-phase motors
DC Motors
NEMA Design D high slip
NEMA 56 or smaller frame
IEC 80 or smaller frame
50Hz motors
Intermittent duty motors (S2 or S3)
TENV – Totally Enclosed Non-Ventilated
TEAO – Totally Enclosed Air-Over
(TEBC – Totally Enclosed Blower Cooled)
Integrated AC drive (SK200E or SK300E combined with motor)



## Efficiency Requirements for Motors

According to EISA, when motors have a mandated efficiency requirement they are categorized into two classes, Subtype I and Subtype II. In general, motors that needed to be energy efficient per EPA standards now must be premium efficient, Subtype I.

Motors that did not have a required efficiency per EPA but now require an efficiency level in EISA are included in Subtype II (energy efficient). The following is a more detailed list of motors included in each efficiency category.

<b>Premium efficiency [Subtype I] – must match all of the following criteria</b>
IEC or NEMA footed or foot+flange
1-200hp
Poles 2,4,6
230/460V-60Hz
Motor or brakemotor
NEMA 140 frame& larger or IEC 90 frame & larger
NEMA Design A or B

<b>Energy efficiency [Subtype II] - Meets the premium efficiency guidelines except:</b>
Footless IEC or NEMA Flange (NEMA-C or IEC B5 or B14)
Other 60Hz voltages (like 208V and 575V)
8 pole
201-500hp
NEMA Design C
U-Frame

### Canada

Three-phase electric induction motors are included in the products governed under Canada's Energy Efficiency Regulations (the Regulations). Natural Resources Canada (NRCAN) proposes to amend the Regulations in order to

- Enforce more stringent Minimum Energy Performance Standards (MEPS) on suppliers for electric motors, imported or shipped inter-provincially for sale or lease in Canada, and
- Expand the scope to include motors which were previously excluded from the Regulations.

The updated Regulations for motors sold in Canada contains three elements:

- Increase the motor efficiency requirements for 1 to 200 HP (0.75 to 150 kW) class motors to include premium efficiency levels.
- Eliminate most of the current exclusions for 1 to 200 HP(0.75 to 150 kW) motors so that they will be required to meet the current efficiency levels.
- Extend coverage to include 201 to 500 HP (151 kW to 185 kW) motors, which were previously excluded, to the current efficiency level standards.

## Standard Efficient Motors

A standard efficiency motor is defined as a rotating machine rated for continuous duty operation that converts electrical power into mechanical power and:

- is an electric induction motor with a polyphase, squirrel cage type design,
- has a minimum output rating of 1 HP (0.746 kW) and up to and including 500 HP (375 kW),
- has a rated voltage of not more than 600 volts AC.
- has a rated frequency of 50/60 Hz or 60 Hz,
- is open or enclosed construction and includes explosion-proof enclosures,
- is constructed to NEMA T frame/U frame dimensions or the IEC equivalent dimensions,
- is NEMA design A, B or C, or IEC design N or H,
- is designed to operate at a single speed,
- has 2, 4, 6 or 8 pole construction,
- is of foot mounted construction or flange mounted construction with or without feet or detachable feet.
- has an IP code from 00 to 66

## Premium efficient motors

A premium efficiency motor, is defined in the description above, and includes all of the additional classifications:

- rated size of 1 HP  $\geq$  200 HP or IEC design motor of size greater than 0.746 kW  $\geq$  150 kW, and
- 2, 4, or 6 poles, and
- NEMA T frame or IEC frame designation of 90 or above, and
- NEMA design A or B, or IEC design N, and
- standard NEMA shaft, R-shaft or S-shaft or an IEC equivalent.

## Energy efficient motors

a motor, as defined in the premium efficiency category, with any of the following classifications, including integral gearmotors:

- 8-pole construction, or
- U frame or equivalent IEC dimensions, or
- NEMA design C or IEC design H, or
- close-coupled pump motor, or
- fire pump duty motor, or
- vertically-mounted solid shaft thrust motor, as tested in the horizontal configuration, or
- footless construction, or
- 2, 4, or 6-pole, NEMA design B motor of size greater than 200 HP and up to and including 500 HP or IEC design N motor of size greater than 150 kW and up to and including 375 kW.





## European Union

New efficiency classes IE1, IE2, IE3 The new standard IEC 60034-30:2008 replaces the various national systems. At the same time, with the IEC 60034-2-1:2007 standard, a new procedure for the measurement of efficiency has been introduced which also contributes to international cohesiveness.

### Efficiency Levels

As of June 16 2011, only motors of efficiency class IE2 or better may be used for continuous operation of standard motors with 1hp (0.75 kW) and more in the EU. The basis for this is ErP 2009/125/EC VO640-2009.

Efficiency Level (Europe - New) IEC600034-30	Efficiency Level (Europe - Old) CEMEP
IE3	New
IE2	EFF1
IE1	EFF2

### Motors included in the efficiency requirements

- Single speed, three-phase induction motors 50 Hz or 50/60 Hz
- 2, 4 and 6 poles
- Rated voltage up to 1000 V
- Rated power between 0.75 kW and 375 kW
- Continuous duty operation S1 or S3 with cyclic duration factor of 80% or higher

### Effective dates:

- June 16, 2011, motors shall not be less efficient than the IE2 efficiencies
- January 1, 2015 motors with a rated output of 7.5-375 kW shall not be less efficient than the IE3 or should meet the IE2 efficiency and be used with an AC drive;
- January 1, 2017 all motors with a rated output of 0.75-375 kW shall not be less efficient than the IE3 or meet IE2 standards and be used in conjunction with an AC speed drive.

### Exceptions

- Submersible motors;
- Motors completely integrated in a product (gear, pump, fan or compressor,...) where the energy performance cannot be tested separate from the product
- Motors specifically designed to operate:
  - At altitudes exceeding 1000 meters elevation;
  - Where ambient temperature is above 40 °C;
  - In max. operating temperature above 400 °C;
  - Where ambient temperatures are less than -15 °C or less than 0 °C for an air cooled motors;
  - Water cooled motors with cooling water below 5 °C or exceeding 25 °C;
  - In explosive atmospheres per Directive 94/9/EC
- Brake motors.





## USA

Directive	Preferred Voltages	Circuit	Frequency
EISA 2007	230/460V	YY/Y	60Hz
Designation	Energy Efficient	Premium Efficient	
Power range	1.0 - 500hp / 0.75 - 375kW	1.0-200 hp / 0.75 - 150kW	
Mandatory Implementation Date	1997	12.19.2010	
Number of Poles	2,4,6,8	2,4,6	
Relevant Exceptions • High/Energy Efficiency • Premium Efficiency	1. Special Shafts NORD gear motors (direct attachment) 2. TEAO, TENV Totally enclosed air-over and non-ventilated motors 3. Switchable multi-speed motors 4. Intermittant operation / Short Term Operation: The directive only applies to motors in continuous operation. Other operating modes are exempted from the directive, e.g.: • S2   Explanation of Duty Classes <a href="#">↩</a> ⇒ 152 • S3 • S6 5. Single phase motors		
Relevant Exceptions	N/A	1. Flange version motors 2. Vertical shaft outlet 3. NEMA Desinged C face Motors 4. Motors with voltages less than 600V and other than 230V or 460V including a +/-10% tolerance	
	Motor Data <a href="#">↩</a> ⇒ 168 - 177		

## Mexico

Directive	Preferred Voltages	Circuit	Frequency
NOM-016 ENER-2010	127/220V 440V	Δ/Y	60Hz
Designation	MEPS		
Power range	1.0-500hp / 0.75 - 373kW		
Mandatory Implementation Date	12.19.2010		
Number of Poles	2,4,6,8		
Relevant Exceptions • MEPS	1. Switchable pole motors 2. Single phase motors 3. Intermittent operation / Short term operation The directive only applies to motors in continuous operation. Other operating modes are exempted from the directive. e.g.: • S2   Explanation of Duty Classes <a href="#">↩</a> ⇒ 152 • S3 • S6 Motor Data <a href="#">↩</a> ⇒ 168 - 177		



# Energy Efficiency Regulations





## Canada

Directive	Preferred Voltages	Circuit	Frequency
Energy Efficiency Regulations 1997 Updated Bulletin on Amending the Standards June 2010	332/575V	$\Delta/Y$	60Hz
Designation	Energy Efficient	Premium Efficient	
Power range	1.0 - 500hp / 0.75 - 375kW	1.0-200 hp / 0.75 - 150kW	
Mandatory Implementation Date	1997	01.01.2011	
Number of Poles	2,4,6,8	2,4,6	
Relevant Exceptions • High/Energy Efficiency • Premium Efficiency	1. TENV Non-ventilated motors 2. Switchable multi-speed motors 3. Intermittant operation / Short Term Operation: The directive only applies to motors in continuous operation. Other operating modes are exempted from the directive: <ul style="list-style-type: none"> <li>• S2</li> <li>• S3</li> <li>• S6</li> </ul> Explanation of Duty Classes <a href="#">↗</a> ⇒ 152 Motor Data <a href="#">↗</a> ⇒ 168 - 177 4. Single phase motors		
Relevant Exceptions	N/A	1. Gear Motors 2. Flange version motors 3. Vertical shaft outlet 4. NEMA Design C or IEC Design H NORD IE2 or "high efficiency" motors have IEC Design H characteristics.	





## European Union

Directive	Preferred Voltages	Circuit	Frequency
ErP 2009/125/IEC VO 640-2009	230/400V 400/690V	Δ/Y	50Hz
Designation	IE2 / High Efficient	IE3 / Premium Efficient	
Power range	0.75 - 375kW		
Mandatory Implementation Date	06.16.2011	01.01.2015 for P ≥ 7.5kW (10hp) 01.01.2017 for P < 7.5 kW (10hp)	
Number of Poles	2,4,6		
Relevant Exceptions • IE2 • IE3	<p>1. Intermittent operation / Short term operation The directive only applies to motors in continuous operation. Operating modes other than S1 as per IEC 60034-1 are exempted from the regulations. e.g.:</p> <ul style="list-style-type: none"> <li>• S3-70%</li> <li>• S6-80%</li> <li>• S9</li> </ul> <p>Explanation of Duty Classes  ⇒ 152 Motor Data  ⇒ 168 - 177</p> <p>2. Brake Motors 3. Switchable multi-speed motors 4. ATEX motors Motors for explosion protection (gas and dust) are exempted from the directive but may be classified according to IE 5. Ambient temperature The directive does not apply to motors which are rated for ambient temperatures &gt; 40°C or &lt;0°F ie: • T<sub>amb</sub> = -20°C...+45°C 6. Installation altitude The directive does not apply to motors which are rated for an installation altitude greater than 1000m above sea level. 7. Single phase motors</p>		
Special Features	N/A	<b>IE2 + Frequency Inverters</b> IE2 motors that may be used with inverters can also be used as an alternative to IE3	







## Switzerland



Directive	Preferred Voltages	Circuit	Frequency
Energy Ordinance AS2009	230/400V 400/690V	$\Delta/Y$	50Hz 50/60Hz

Designation	IE2 / High Efficient	IE3 / Premium Efficient
Power range	0.75 - 375kW	
Mandatory Implementation Date	07.01.2011	open
Number of Poles	2,4,6	
Relevant Exceptions • IE2 • IE3	<p>1. Intermittent operation / Short term operation The directive only applies to motors in continuous operation S1 or S3 &gt; 80%. Operating modes other than S1 as per IEC 60034-1 are exempted from the regulations. e.g.:</p> <ul style="list-style-type: none"> <li>• S3-70%</li> <li>• S6-80%</li> <li>• S9</li> </ul> <p style="margin-left: 40px;">Explanation of Duty Classes  <math>\Rightarrow</math> 152</p> <p>Motor Data  <math>\Rightarrow</math> 168 - 177</p> <p>2. Switchable multi-speed motors</p> <p>3. AC vector drive operation. Special motors for AC vector drive operation as per standard IEC 60034-25 of the International Electrical Engineering Commission.</p> <p>4. ATEX motors Motors for explosion protection (gas and dust) are exempted from the directive but may be classified according to IE.</p> <p>5. Ambient temperature The above directive does not apply to motors which are rated for ambient temperatures &gt; 40°C or &lt;0°F (up to 600W) or &lt;15°C, eg.:</p> <ul style="list-style-type: none"> <li>• <math>T_{amb} = -20^{\circ}\text{C} \dots +45^{\circ}\text{C}</math></li> </ul> <p>6. Installation altitude The directive does not apply to motors which are rated for an installation altitude greater than 1000m above sea level.</p> <p>7. Single phase motors</p>	







## China

Directive	Preferred Voltages	Circuit	Frequency
GB 18613-2006	230/400V Maximum 690V	Δ/Y	50Hz
Designation	Grade 2	Grade 1	
Power range	0.55 - 315kW	3.0 - 315kW	
Mandatory Implementation Date	07.01.2011	Voluntary	
Number of Poles	2,4,6		
Relevant Exceptions • Grade 2 • Grade 1	<p>1. Intermittant operation / Short Term Operation: The directive only applies to motors in continuous operation. Operating modes other than S1 as per IEC 60034-1 are exempted from the regulations. eg:</p> <ul style="list-style-type: none"> <li>• S3-70%</li> <li>• S6-80%</li> <li>• S9</li> </ul> <p style="margin-left: 40px;">Explanation of Duty Classes  ⇒ 152</p> <p style="margin-left: 40px;">Motor Data  ⇒ 168 - 177</p> <p>2. Switchable multi-speed motors</p> <p>3. Single phase motors</p>		

## South Korea

Directive	Preferred Voltages	Circuit	Frequency
MKE's Notification 2009-317	220/380V 440V	Δ/Y	60Hz
Designation	MEPS		
Power range	0.75-15kW	15-37kW	37-200kW
Mandatory Implementation Date	07.01.2010	01.01.2010	07.01.2007
Number of Poles	2,4,6,8*		
Relevant Exceptions • MEPS	<p>1. The Directive only applies to motors in continuous operation. Operating modes other than S1 as per IEC 60034-1 are exempted from the regulations. e.g. :</p> <ul style="list-style-type: none"> <li>• S3-70%</li> <li>• S6-80%</li> <li>• S9</li> </ul> <p style="margin-left: 40px;">Explanation of Duty Classes  ⇒ 152</p> <p style="margin-left: 40px;">Motor Data  ⇒ 168 - 177</p> <p>2. Switchable multi-speed motors</p> <p>3. TENV non-ventilated motors</p> <p>4. 6-pole motors with powers above 160kW</p> <p>5. 8-pole motors with powers above 110kW</p> <p>6. Single phase motors</p> <p>* The statutory MEPS comes into effect at a later date for 8-pole motors: from 01.01.2010 37-110kW from 01.01.2011 0.75 - 37kW</p>		





## Australia

Directive	Preferred Voltages	Circuit	Frequency
MEPS AS/NZS 1359.5	230/400V	$\Delta/Y$	50Hz
Designation	MEPS	High Efficiency (Premium Efficient)	
Power range	0.73 -185 kW	0.73 -185 kW	
Mandatory Implementation Date	04.01.2006	Voluntary	
Number of Poles	2,4,6,8		
Relevant Exceptions • MEPS • High Efficiency	<p>1. Intermittant operation / Short Term Operation: The directive only applies to motors in continuous operation. Operating modes other than S1 as per IEC 60034-1 are exempted from the regulations. eg:</p> <ul style="list-style-type: none"> <li>• S3-70%</li> <li>• S6-80%</li> <li>• S9</li> </ul> <p style="margin-left: 40px;">Explanation of Duty Classes  <math>\Rightarrow</math> 152</p> <p style="margin-left: 40px;">Motor Data  <math>\Rightarrow</math> 168 - 177</p> <p>2. Motors for AC vector drive operation 3. Switchable multi-speed motors 4. Single phase motors</p>		

## Brazil

Directive	Preferred Voltages	Circuit	Frequency
Decreto n° 4.508	230/380V 440V	$\Delta/Y$	60Hz
Designation	ALTO RENDIMENTO		
Power range	0.75 - 185kW		
Mandatory Implementation Date	12.08.2009		
Number of Poles	2,4,6, 8		
Relevant Exceptions • ALTO RENDIMENTO	<p>1. Intermittent operation / Short term operation The directive only applies to motors in continuous operation. Operating modes other than S1 as per IEC 60034-1 are exempted from the regulations. e.g.:</p> <ul style="list-style-type: none"> <li>• S3-70%</li> <li>• S6-80%</li> <li>• S9</li> </ul> <p style="margin-left: 40px;">Explanation of Duty Classes  <math>\Rightarrow</math> 152</p> <p style="margin-left: 40px;">Motor Data  <math>\Rightarrow</math> 168 - 177</p> <p>2. Motors for AC vector drive operation. 3. Switchable multi-speed motors 4. 6-pole motors with powers above 150kW 5. 8-pole motors with powers above 110kW 6. Single phase motors</p>		





## US & Canadian Motor Efficiencies for Energy Efficient 60Hz Motors

Full-Load Efficiencies of General Purpose Electric Motors [Subtype II] - Energy efficiency								
Motor Horse-power	Nominal full load efficiency							
	Open motors				Enclosed motors			
	8 pole	6 pole	4 pole	2 pole	8 pole	6 pole	4 pole	2 pole
1	74.0	80.0	82.5		74.0	80.0	82.5	75.5
1.5	75.5	84.0	84.0	82.5	77.0	85.5	84.0	82.5
2	85.5	85.5	84.0	84.0	82.5	86.5	84.0	84.0
3	86.5	86.5	86.5	84.0	84.0	87.5	87.5	85.5
5	87.5	87.5	87.5	85.5	85.5	87.5	87.5	87.5
7.5	88.5	88.5	88.5	87.5	85.5	89.5	89.5	88.5
10	89.5	90.2	89.5	88.5	88.5	89.5	89.5	89.5
15	89.5	90.2	91.0	89.5	88.5	90.2	91.0	90.2
20	90.2	91.0	91.0	90.2	89.5	90.2	91.0	90.2
25	90.2	91.7	91.7	91.0	89.5	91.7	92.4	91.0
30	91.0	92.4	92.4	91.0	91.0	91.7	92.4	91.0
40	91.0	93.0	93.0	91.7	91.0	93.0	93.0	91.7
50	91.7	93.0	93.0	92.4	91.7	93.0	93.0	92.4
60	92.4	93.6	93.6	93.0	91.7	93.6	93.6	93.0
75	93.6	93.6	94.1	93.0	93.0	93.6	94.1	93.0
100	93.6	94.1	94.1	93.0	93.0	94.1	94.5	93.6
125	93.6	94.1	94.5	93.6	93.6	94.1	94.5	94.5
150	93.6	94.5	95.0	93.6	93.6	95.0	95.0	94.5
200	93.6	94.5	95.0	94.5	94.1	95.0	95.0	95.0
250	94.5	94.5	95.4	94.5	94.5	95.0	95.0	95.4

## US & Canadian Motor Efficiencies for Premium Efficient 60Hz Motors

Full-Load Efficiencies of General Purpose Electric Motors [Subtype I Premium Efficiency]						
Motor Horse-power	Nominal full load efficiency					
	Open motors			Enclosed motors		
	6 pole	4 pole	2 pole	6 pole	4 pole	2 pole
1	82.5	85.5	77.0	82.5	85.5	77.0
1.5	86.5	86.5	84.0	87.5	86.5	84.0
2	87.5	86.5	85.5	88.5	86.5	85.5
3	88.5	89.5	85.5	89.5	89.5	86.5
5	89.5	89.5	86.5	89.5	89.5	88.5
7.5	90.2	91.0	88.5	91.0	91.7	89.5
10	91.7	91.7	89.5	91.0	91.7	90.2
15	91.7	93.0	90.2	91.7	92.4	91.0
20	92.4	93.0	91.0	91.7	93.0	91.0
25	93.0	93.6	91.7	93.0	93.6	91.7
30	93.6	94.1	91.7	93.0	93.6	91.7
40	94.1	94.1	92.4	94.1	94.1	92.4
50	94.1	94.5	93.0	94.1	94.5	93.0
60	94.5	95.0	93.6	94.5	95.0	93.6
75	94.5	95.0	93.6	94.5	95.4	93.6
100	95.0	95.4	93.6	95.0	95.4	94.1
125	95.0	95.4	94.1	95.0	95.4	95.0
150	95.4	95.8	94.1	95.8	95.8	95.0
200	95.4	95.8	95.0	95.8	96.2	95.4

# Motor Efficiency Ratings



## European Motor Efficiencies 50Hz

Efficiency Classes of IE1, IE2, and IE3 motors

Motor Power [kW]	IE1, 50Hz			IE2, 50Hz			IE3, 50Hz		
	2 pole	4 pole	6 pole	2 pole	4 pole	6 pole	2 pole	4 pole	6 pole
0.75	72.1	72.1	70.0	77.4	79.6	75.9	80.7	82.5	78.9
1.1	75.0	75.0	72.9	79.6	81.4	78.1	82.7	84.1	81.0
1.5	77.2	77.2	75.2	81.3	82.8	79.8	84.2	85.3	82.5
2.2	79.7	79.7	77.7	83.2	84.3	81.8	85.9	86.7	84.3
3.0	81.5	81.5	79.7	84.6	85.5	83.3	87.1	87.7	85.6
4.0	83.1	83.1	81.4	85.8	86.6	84.6	88.1	88.6	86.8
5.5	84.7	84.7	83.1	87.0	87.7	86.0	89.2	89.6	88.0
7.5	86.0	86.0	84.7	88.1	88.7	87.2	90.1	90.4	89.1
11	87.6	87.6	86.4	89.4	89.8	88.7	91.2	91.4	90.3
15	88.7	88.7	87.7	90.3	90.6	89.7	91.9	92.1	91.2
18.5	89.3	89.3	88.6	90.9	91.2	90.4	92.4	92.6	91.7
22	89.9	89.9	89.2	91.3	91.6	90.9	92.7	93.0	92.2
30	90.7	90.7	90.2	92.0	92.3	91.7	93.3	93.6	92.9
37	91.2	91.2	90.8	92.5	92.7	92.2	93.7	93.9	93.3
45	91.7	91.7	91.4	92.9	93.1	92.7	94.0	94.2	93.7
55	92.1	92.1	91.9	93.2	93.5	93.1	94.3	94.6	94.1
75	92.7	92.7	92.6	93.8	94.0	93.7	94.7	95.0	94.6
90	93.0	93.0	92.9	94.1	94.2	94.0	95.0	95.2	94.9
110	93.3	93.3	93.3	94.3	94.5	94.3	95.2	95.4	95.1
132	93.5	93.5	93.5	94.6	94.7	94.6	95.4	95.6	95.4
160	93.8	93.8	93.8	94.8	94.9	94.8	95.6	95.8	95.6
200-375	94.0	94.0	94.0	95.0	95.1	95.0	95.8	96.0	95.8

Efficiency classes for 50Hz in accordance with IEC 60034-30:2008





## European Motor Efficiencies 60Hz

Efficiency Classes of IE1, IE2, and IE3 motors									
Motor Power [kW]	IE1, 60Hz			IE2, 60HZ			IE3, 60Hz		
	2 pole	4 pole	6 pole	2 pole	4 pole	6 pole	2 pole	4 pole	6 pole
0.75	77.0	78.0	73.0	75.5	82.5	80.0	77.0	85.5	82.5
1.1	78.5	79.0	75.0	82.5	84.0	85.5	84.0	86.5	87.5
1.5	81.0	81.5	77.0	84.0	84.0	86.5	85.5	86.5	88.5
2.2	81.5	83.0	78.5	85.5	87.5	87.5	86.5	89.5	89.5
3.7	84.5	85.0	83.5	87.5	87.5	87.5	88.5	89.5	89.5
5.5	86.0	87.0	85.0	88.5	89.5	89.5	89.5	91.7	91.0
7.5	87.5	87.5	86.0	89.5	89.5	89.5	90.2	91.7	91.0
11	87.5	88.5	89.0	90.2	91.0	90.2	91.0	92.4	91.7
15	88.5	89.5	89.5	90.2	91.0	90.2	91.0	93.0	91.7
18.5	89.5	90.5	90.2	91.0	92.4	91.7	91.7	93.6	93.0
22	89.5	91.0	91.0	91.0	92.4	91.7	91.7	93.6	93.0
30	90.2	91.7	91.7	91.7	93.0	93.0	92.4	94.1	94.1
37	91.5	92.4	91.7	92.4	93.0	93.0	93.0	94.5	94.1
45	91.7	93.0	91.7	93.0	93.6	93.6	93.6	95.0	94.5
55	92.4	93.0	92.1	93.0	94.1	93.6	93.6	95.4	94.5
75	93.0	93.2	93.0	93.6	94.5	94.1	94.1	95.4	95.0
90	93.0	93.2	93.0	94.5	94.5	94.1	95.0	95.4	95.0
110	93.0	93.5	94.1	94.5	95.0	95.0	95.0	95.8	95.8
150	94.1	94.5	94.1	95.0	95.0	95.0	95.4	96.2	95.8
185-375	94.1	94.5	94.1	95.4	95.4	95.0	95.8	96.2	95.8



Efficiency classes for 60Hz in accordance with IEC 60030-30:2008





## Motors Dimensions

- IG, F, IGF Option Motor Dimensions
- IG, F, IGF Option Brakemotor Dimensions
- HR, MS Dimensions
- MG Dimensions
- WE, RD, RDD Motor Dimensions
- WE, RD, RDD Brakemotor Dimensions
- Conduit Box & Cable Entry Dimensions
- Connection Diagrams

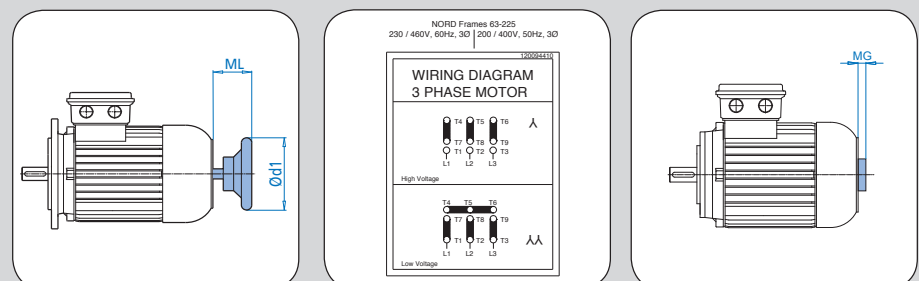
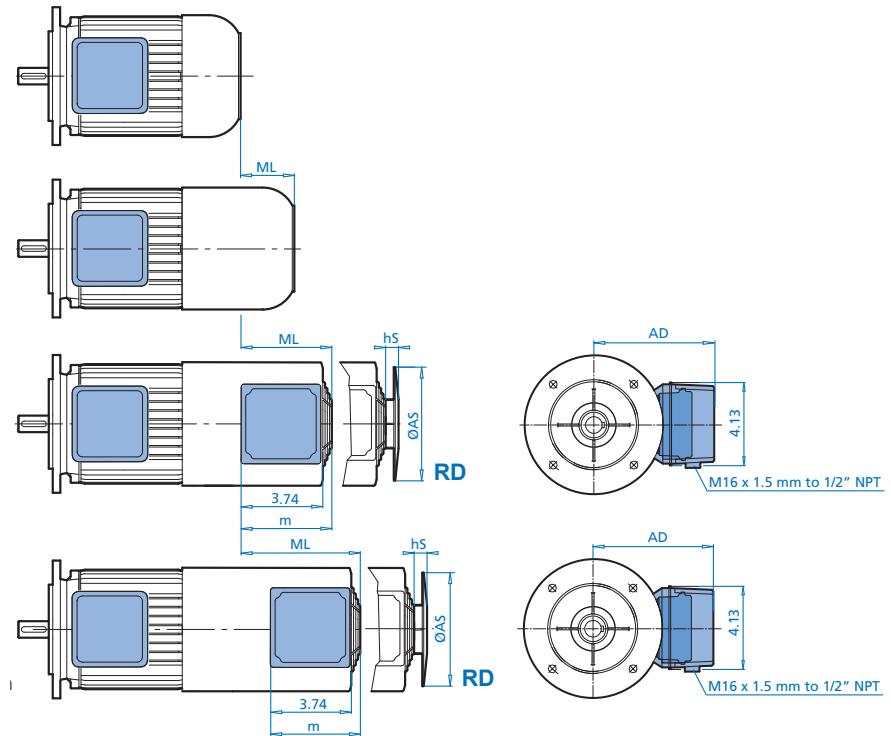

# IG, F, IGF Option Motor Dimensions

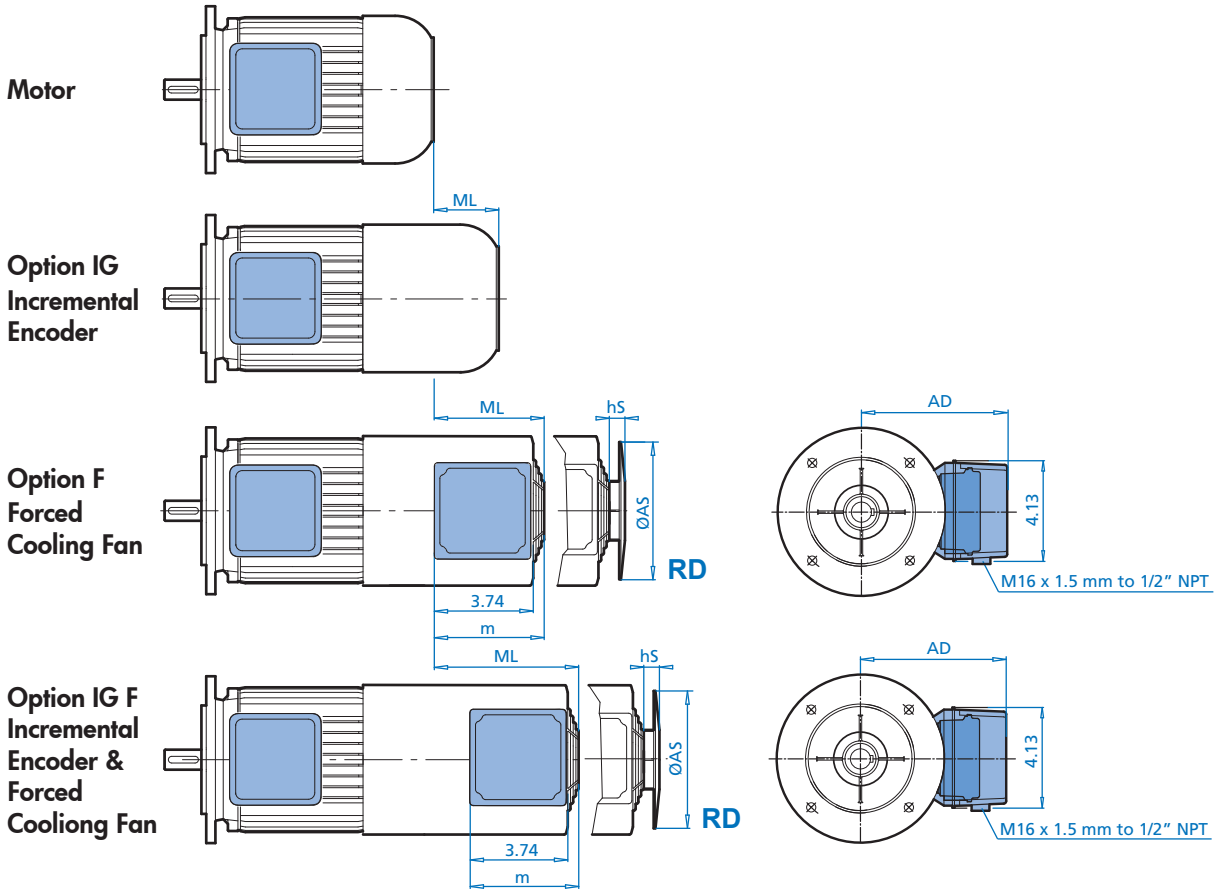

Motor Frame Size	Efficiency			IG						IG F				
	SE	EE	PE	ML	ML	AS	hS	AD	m	ML	AS	hS	AD	m
63	S/L			2.17	3.46	5.24	1.46	4.49	4.21	6.22	5.24	1.46	4.49	4.21
71	S/L			2.20	3.50	5.91	1.46	4.84	4.21	5.67	5.91	1.46	4.84	4.21
80	S/L	SH/LH	LP	2.40	3.54	6.69	1.57	5.20	4.21	5.51	6.69	1.57	5.20	4.21
90	S/L	SH/LH	SP/LP	2.83	4.09	7.40	1.18	5.59	4.61	5.87	7.40	1.18	5.59	4.61
100	L/LA	LH/AH	LP/AP	2.72	3.74	8.27	1.10	5.94	4.61	6.10	8.27	1.10	5.94	4.61
112		SH/LH		2.68	3.90	9.80	1.30	6.42	4.61	5.87	9.80	1.30	6.42	4.61
112	M	MH	MP	2.68	3.90	9.80	1.30	6.42	4.61	5.87	9.80	1.30	6.42	4.61
132	S/M/LA	SH/MH	SP/MP	2.48	4.53	11.81	0.98	7.20	5.00	6.10	11.81	0.98	7.20	5.00

\* Not available with NEMA dimensioned motors.



# IG, F, IGF Option Brakemotor Dimensions

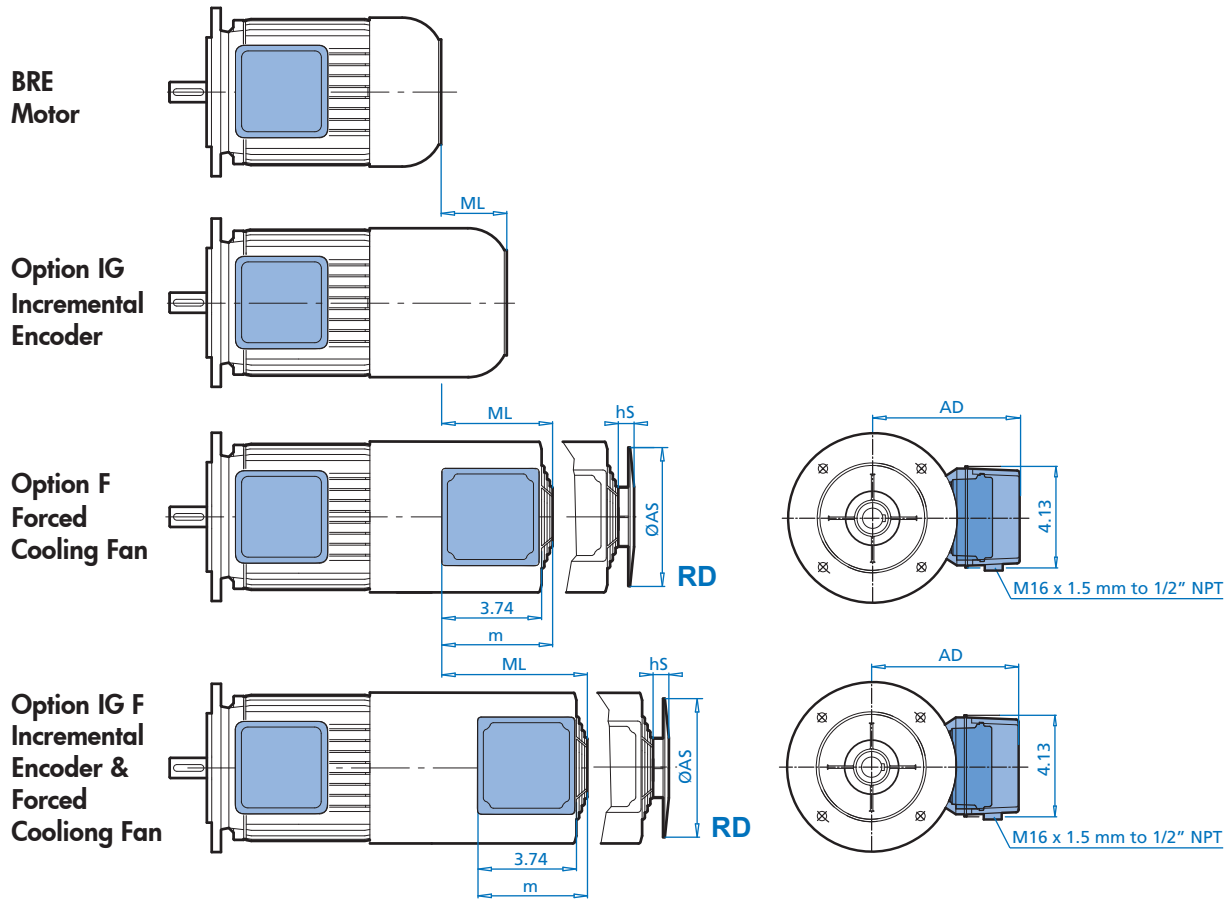

Motor Frame Size	Efficiency			IG		F				IG F				
	SE	EE	PE	ML	ML	AS	hS	AD	m	ML	AS	hS	AD	m
63	S/L			2.44	3.54	5.24	1.46	4.49	4.21	4.92	5.24	1.46	4.49	4.21
71	S/L			2.91	3.70	5.91	1.46	4.84	4.21	5.47	5.91	1.46	4.84	4.21
80	S/L	SH/LH	LP	2.24	3.54	6.69	1.57	5.20	4.21	5.51	6.69	1.57	5.20	4.21
90	S/L	SH/LH	SP/LP	2.76	3.94	7.40	1.18	5.59	4.61	5.71	7.40	1.18	5.59	4.61
100	L/LA	LH/AH	LP/AP	2.76	4.13	8.27	1.10	5.94	4.61	5.51	8.27	1.10	5.94	4.61
112		SH/LH		2.52	4.13	9.80	1.30	6.42	4.61	5.51	9.80	1.30	6.42	4.61
112	M	MH	MP	2.52	4.13	9.80	1.30	6.42	4.61	5.51	9.80	1.30	6.42	4.61
132	S/M/LA	SH/MH	SP/MP	2.56	4.92	11.81	0.98	7.20	5.00	6.10	11.81	0.98	7.20	5.00

\* Not available with NEMA dimensioned motors.

# HR, MS Option Dimensions

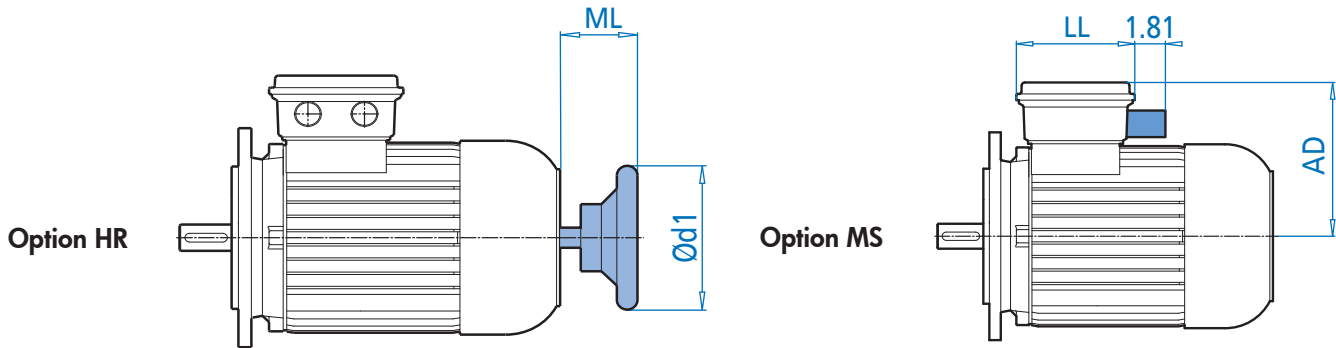

## Standard Motor

Motor Frame Size	Efficiency			HR		MS	
	SE	EE	PE	ML	d1	LL	AD
63	S/L	-	-	1.54	3.94	4.49	5.51
71	S/L	-	-	1.57	3.94	4.49	5.87
80	S/L	SH/LH	LP	1.93	3.94	4.49	6.22
90	S (B3)	-	-	1.65	6.30	4.49	6.42
90	S/L	SH/LH	SP/LP	2.64	6.30	4.49	6.42
100	L/LA	LH/AH	LP/AP	2.99	6.30	4.49	6.85
112	-	SH/LH	-	2.91	6.30	4.49	7.24
112	M	MH	MP	2.91	6.30	4.49	7.24
132	S (B3)	-	-	3.19	7.87	4.80	8.03
132	S/M/LA	SH/MH	SP/MP	4.69	7.87	4.80	8.03

\* Not available with NEMA dimensioned motors.

## Brakemotor

Motor Frame Size	Efficiency			HR		MS	
	SE	EE	PE	ML	d1	LL	AD
63	S/L	-	-	1.69	3.94	4.49	5.51
71	S/L	-	-	1.69	3.94	4.49	5.87
80	S/L	SH/LH	LP	1.97	3.94	4.49	6.22
90	S (B3)	-	-	1.30	6.30	4.49	6.42
90	S/L	SH/LH	SP/LP	2.28	6.30	4.49	6.42
100	L/LA	LH/AH	LP/AP	3.15	6.30	4.49	6.85
112	-	SH/LH	-	3.03	6.30	4.49	7.24
112	M	MH	MP	3.03	6.30	4.49	7.24
132	S (B3)	-	-	2.87	7.87	4.80	8.03
132	S/M/LA	SH/MH	SP/MP	4.37	7.87	4.80	8.03

\* Not available with NEMA dimensioned motors.

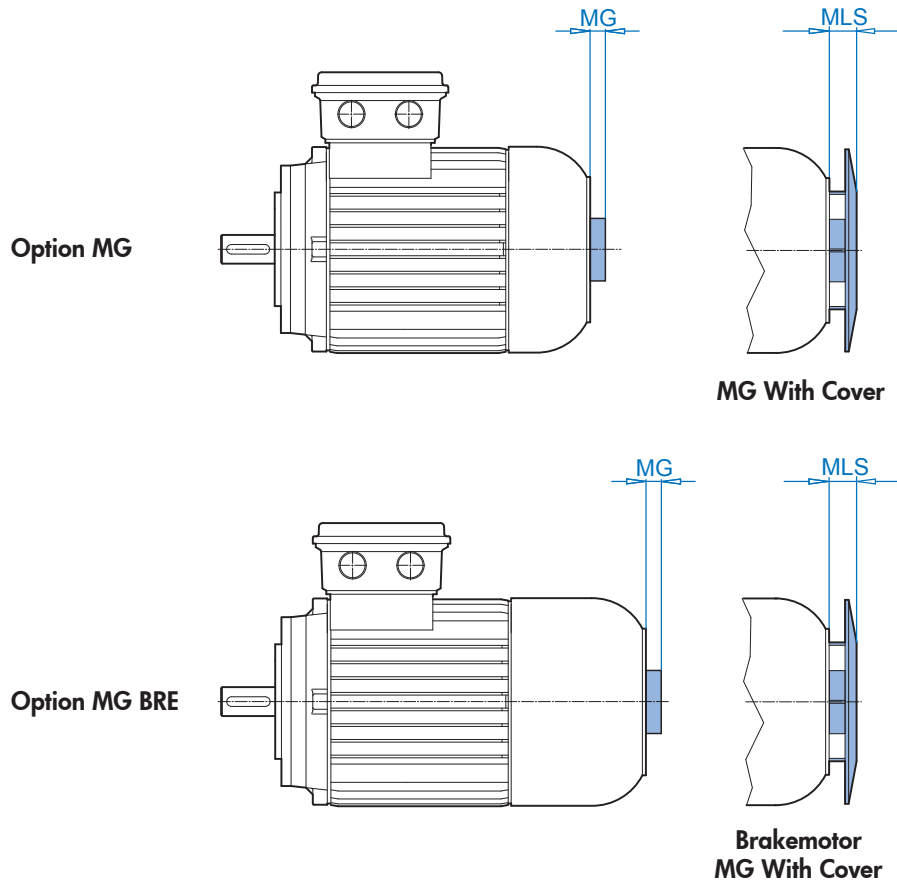

Motor Frame Size	Efficiency			MG		BRE + MG	
	SE	EE	PE	MG	MLS	BRE + MG	BRE + MLS
63	S/L	-	-	0.43	0.87	0.59	1.02
71	S/L	-	-	0.47	0.91	0.67	1.10
80	S/L	SH/LH	LP	0.39	0.75	0.47	0.83
90	S/L	SH/LH	SP/LP	0.55	0.91	0.51	0.87
100	L/LA	LH/AH	LP/AP	0.51	0.83	0.51	0.87
112	-	SH/LH	-	0.47	0.83	0.51	0.87
112	M	MH	MP	0.47	0.83	0.51	0.83
132	S/M/MA	SH/MH	SP/MP	0.39	0.83	0.35	0.79

# WE, RD, RDD Option Motor Dimensions



## Standard Motor

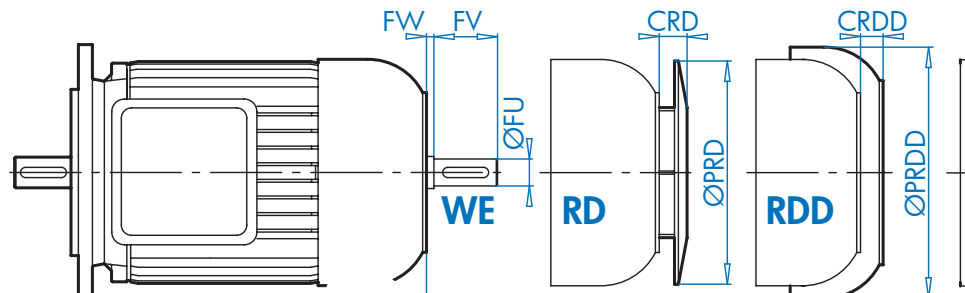

Motor Frame Size	Efficiency			WE								RD		RDD	
	SE	EE	PE	DA	GC	CW	EA	FW	DC	EC	FA	ØAS	DS	ØAO	DO
	[mm]											[in]			
63	S/L	-	-	11	12.5	23	23	0	M4	16	4	4.84	0.43	6.02	1.06
71	S/L	-	-	11	12.5	24	23	1	M4	16	4	5.43	0.43	6.65	0.94
80	S/L	SH/LH	LP	14	16.0	33	30	3	M5	20	5	6.14	0.59	7.20	1.22
90	S/L	SH/LH	SP/LP	19	21.5	47	40	7	M6	32	6	6.93	0.59	7.91	1.22
100	L/LA	LH/AH	LP/AP	24	27.0	56	50	6	M8	40	8	7.64	0.59	8.86	1.10
112	-	SH/LH	-	24	27.0	54	50	4	M8	40	8	8.58	0.59	10.43	1.50
112	M	MH	MP	24	27.0	54	50	4	M8	40	8	8.58	0.59	10.16	1.50
132	S/M/LA	SH/MH	SP/MP	32	35.0	90	80	10	M12	70	10	10.12	0.67	12.51	1.61



**Standard  
BRE**

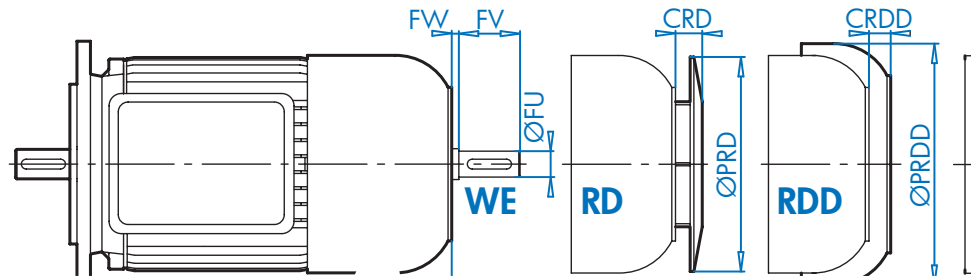

Motor Frame Size	Efficiency			WE								RD		RDD	
	SE	EE	PE	DA	GC	CW	EA	FW	DC	EC	FA	ØAS	DS	ØAO	DO
	[mm]											[in]			
63	S/L	-	-	11	12.5	27	23	4	M4	16	4	4.84	0.43	6.02	1.06
71	S/L	-	-	11	12.5	27	23	4	M4	16	4	5.43	0.43	6.65	0.94
80	S/L	SH/LH	LP	14	16.0	34	30	4	M5	20	5	6.14	0.59	7.20	1.22
90	S/L	SH/LH	SP/LP	19	21.5	48	40	8	M6	32	6	6.93	0.59	7.91	1.22
100	L/LA	LH/AH	LP/AP	24	27.0	60	50	10	M8	40	8	7.64	0.59	8.86	1.10
112	-	SH/LH	-	24	27.0	57	50	7	M8	40	8	8.58	0.59	10.43	1.50
112	M	MH	MP	24	27.0	57	50	7	M8	40	8	8.58	0.59	10.16	1.50
132	S/M/LA	SH/MH	SP/MP	32	35.0	90	80	10	M12	70	10	10.12	0.67	12.51	1.61



# Dimensions Conduit Box & Cable Entry

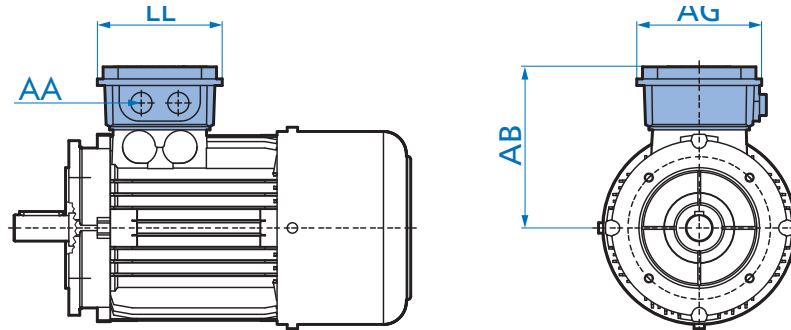

Motor Frame Size	Efficiency			Conduit Box & Cable Entry				
	SE	EE	PE	AD	AG	LL	O	Conduit Adapter
63	S/L	-	-	4.53	3.94	3.94	M20 X 1.5	1/2" NPT
71	S/L	-	-	4.88	3.94	3.94	M20 X 1.5	1/2" NPT
80	S/L	SH/LH	LP	5.59	4.49	4.49	M25 X 1.5	3/4" NPT
90	S/L	SH/LH	SP/LP	5.79	4.49	4.49	M25 X 1.5	3/4" NPT
100	L/LA	LH/AH	LP/AP	6.65	4.49	4.49	M32 X 1.5	1" NPT
112	-	SH/LH	-	7.05	4.49	4.49	M32 X 1.5	1" NPT
112	M	MH	MP	7.05	4.49	4.49	M32 X 1.5	1" NPT
132	S/M/LA	SH/MH	SP/MP	8.03	4.80	4.80	M32 X 1.5	1" NPT

Brakemotor Frame Size	Efficiency			Conduit Box & Cable Entry				
	SE	EE	PE	AD	AG	LL	O	Conduit Adapter
63	S/L	-	-	4.84	3.50	5.28	M20 X 1.5	1/2" NPT
71	S/L	-	-	5.20	3.50	5.28	M20 X 1.5	1/2" NPT
80	S/L	SH/LH	LP	5.59	4.25	6.02	M25 X 1.5	3/4" NPT
90	S/L	SH/LH	SP/LP	5.79	4.25	6.02	M25 X 1.5	3/4" NPT
100	L/LA	LH/AH	LP/AP	6.77	4.25	6.02	M32 X 1.5	1" NPT
112	-	SH/LH	-	7.17	4.25	6.02	M32 X 1.5	1" NPT
112	M	MH	MP	7.17	4.25	6.02	M32 X 1.5	1" NPT
132	S/M/LA	SH/MH	SP/MP	7.91	5.47	7.28	M32 X 1.5	1" NPT



## Connection Diagrams

NORD Frames 63-225  
230 / 460V, 60Hz, 3Ø | 200 / 400V, 50Hz, 3Ø

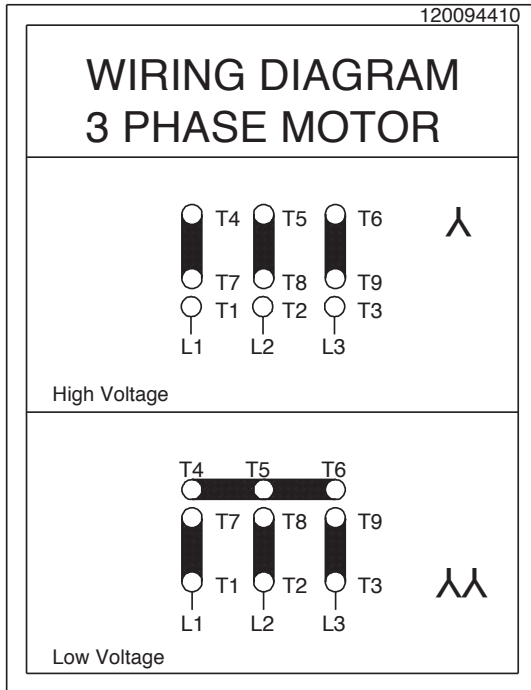

NORD Frames 63 - 225  
460 / 800V, 60Hz, 3Ø | 230 / 400V, 50Hz, 3Ø  
208 / 360V, 60Hz, 3Ø | 400 / 690V, 50Hz, 3Ø  
332 / 575V, 60Hz, 3Ø

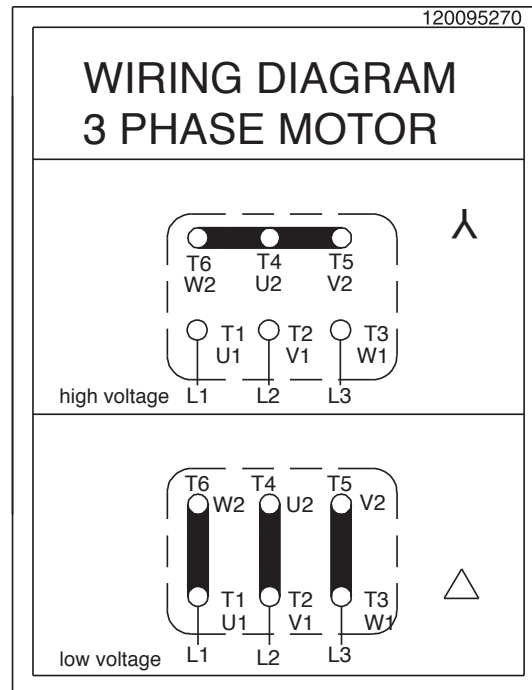

NORD - 2 - SPEED MOTORS  
SINGLE WINDING (4-2 & 8-4 POLE)

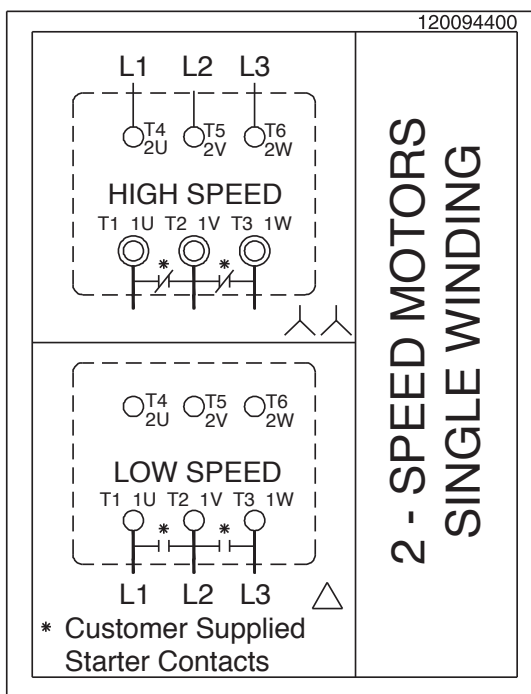

NORD - 2 - SPEED MOTORS  
DUAL WINDING (8-2 POLE)

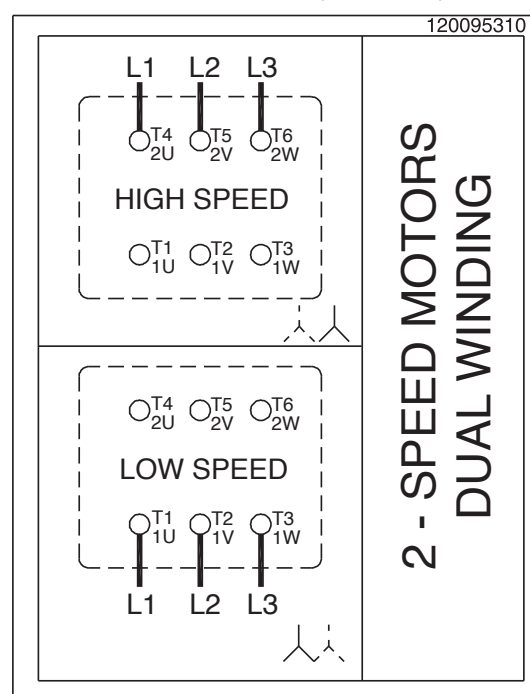



## Connection Diagrams

FROM MOTOR

TERMINAL BLOCK

P1

P2

TO CONTROL DEVICE

- \* MAX. OPERATING VOLTAGE 2.5V.
- \* SWITCH TEMP. 155°C
- \* RESPONSE TIME < 5 SECONDS

**THERMISTOR  
"TF" OPTION**

120095240

FROM MOTOR

TERMINAL BLOCK

P1

P2

TO CONTROL DEVICE

- \* NC (NORMALLY CLOSED)
- \* CONTACTS RATED 1.6A AT 2.50 VAC
- \* 6-500 VAC WORKING RANGE
- \* AUTOMATIC RESET AT 30 ± 15°C TEMP. DROP

**THERMISTATS  
"TW" OPTION**

120095230

W2 U2 V2

U1 V1 W1

L1 N

1 PHASE  
115V\*  
50/60 Hz

\* CAPACITOR IS SUPPLIED

**BLOWER COOLING FAN  
"FC" OPTION**

120095450

OPTION "F" 1 PH

OPTION "F" 3 PH

W2 U2 V2

U1 V1 W1

L1 N

230V  
50 / 60 Hz

380-575V  
50 / 60 Hz

W2 U2 V2

U1 V1 W1

L1 L2 L3

220-332V  
50 / 60 Hz

\* CAPACITOR IS SUPPLIED

**BLOWER COOLING FAN  
"F" OPTION**

120095250

FROM MOTOR

TERMINAL BLOCK

H1

H2

TO CONTROL DEVICE

**SPACE HEATER  
"SH" OPTION**

120095220



## Brakes

- Operation
- Selection-Torque
- Mechanical Options
- Rectifiers
- Selection-Performance
- Connection Diagrams

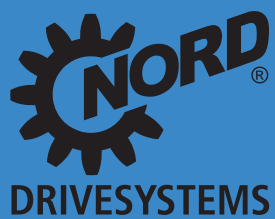
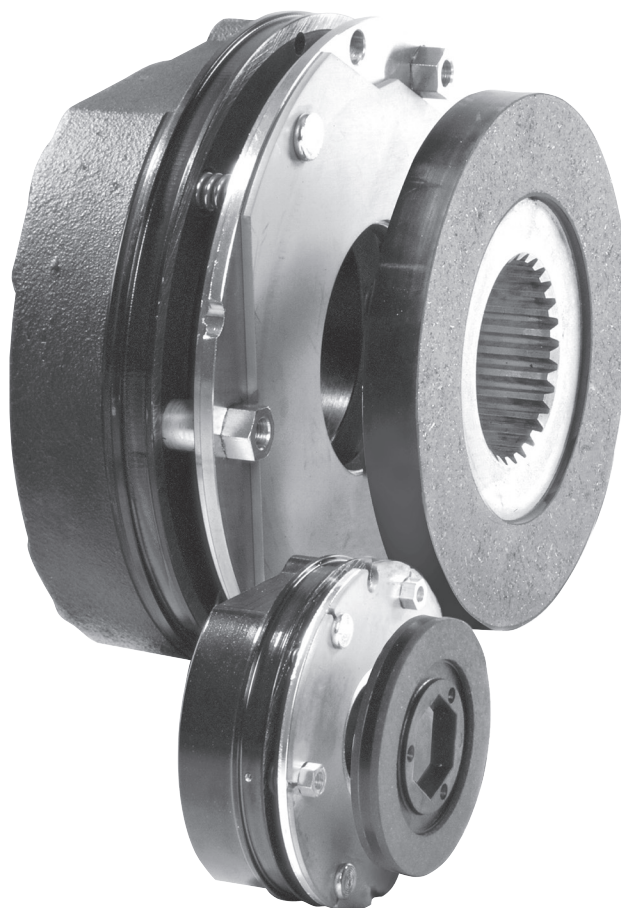

[www.nord.com](http://www.nord.com)

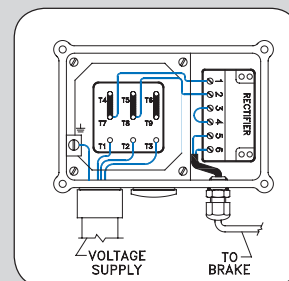
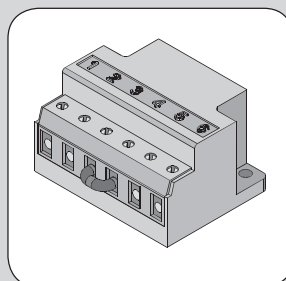
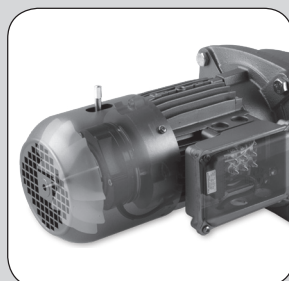



## Motor Brake (Option BRE)

The standard NORD motor brake is spring-set when power is removed from the BRE circuit (power-off). The brake coil utilizes a DC voltage supplied through a rectified power source.

### Advantages

- Each NORD motor frame size has a number of brake sizes available, with different torque capacities.
- Brake torque adjustments are possible by changing the brake spring combinations. In addition, brake sizes from 5-40 Nm (3.7-30 lb-ft) are typically supplied with an additional spanner-nut adjustment on the back of the brake.
- NORD brakes provide a high degree of safety because when power is removed the brake will automatically set to hold the load.
- The brake rotor or brake disc is environmentally safe and asbestos-free.
- The connection between the rectifier and the brake coil is completed at the factory and the brake air-gap is factory-set but can be adjusted in the event of wear.

### Basic Brake Operation

The standard NORD motor brake is "spring set". When power is removed and the brake is de-energized (power-off), the brake springs exert a force against the armature plate in turn preventing the brake rotor (or brake disc) from rotating. When the brake coil is energized (power-on), a magnetic field pulls the armature plate across the air gap to the brake casing, which releases the brake rotor and allows the motor shaft to rotate.

NORD brakes are DC voltage brakes and in most instances are supplied with a motor mounted brake rectifier for easy connections to AC power. AC power is taken directly from the power line or from the terminal block of the motor and converted to DC by the supplied rectifier.

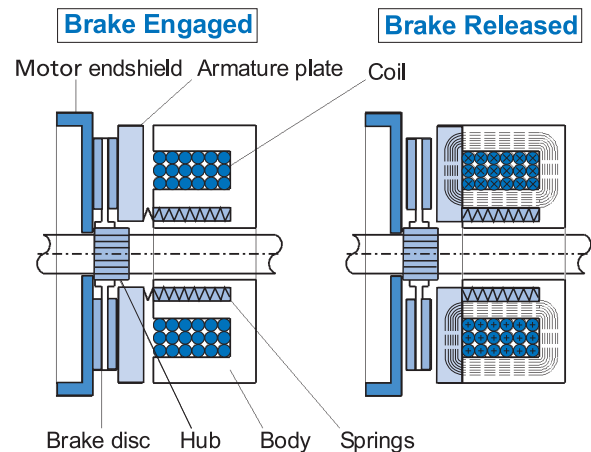

### Brake Selection

The selection of a motor brake system is broken down into five phases. The selection of the braking torque, the selection of the braking times (release times and setting times), the selection of the electrical supply and connection, the selection of brake options, and the final phase is the verification of the permissible brake work.

Each NORD motor may be supplied with a number of brake torque sizes. Each brake may be adjusted to different brake torque values. (pages 203 - 204)

#### Selection steps

- 1) Brake torque selection (page 203)
- 2) Brake times & electrical selection (page 205)
- 3) Electrical supply and connection (page 206 & 228-238)
- 4) Brake options (page 209)
- 5) Brake work verification (page 227)



### IMPORTANT NOTE



If the motor is connected to a frequency inverter, soft start, or is a two-speed motor, the AC power must be supplied separately to the brake rectifier.





## Brake Torque Selection

Each NORD motor size has a number of brake torque sizes available. The BRE value in the table below is the standard brake torque size for each motor.

Example for ordering: SK 32 - S/L BRE10

(BRE 10 indicates a brake torque size of 10 Nm)

## General Selection Considerations

NORD relies on the equipment builder to specify appropriate brake sizing for their application, while giving consideration to the following:

- For most applications, we advise sizing the brake to 1.5 - 2 times the motor rated torque.
- For vertical applications, it may be advisable to size the brake size up to 3 times the motor rated torque.
- For some applications, it may be necessary to specify a reduced brake torque setting to prevent excessive peak load conditions developed at the reducer output.
- On travel drive applications, excessive brake torque may lead to wheel skid; in addition on crane applications excess hoist-cable swing can result.

Motor Size & Efficiency				Brake Size and Torque							
Frame Size	SE	EE	PE		BRE5	BRE10	BRE20	BRE40	BRE60	BRE100	BRE150
				Nm	5	10	20	40	60	100	150
				lb-in	44	89	177	354	531	885	1328
				lb-ft	3.7	7.4	14.8	29.5	44.3	73.8	111
63	S/L			Std.	Opt. * #						
71	S/L			Std.	Opt. *						
80	S	SH		Std.	Opt.	Opt. *					
80	L	LH	LP	Opt.	Std.	Opt. *					
90	S	SH	SP		Opt.	Std.	Opt.				
90	L	LH	LP		Opt.	Std.	Opt.				
100	L	LH	LP			Std.	Opt.	Opt. #			
100	LA	AH	AP			Opt.	Std.	Opt. #			
112		SH					Opt.	Std.	Opt.		
112	M	MH	MP				Opt.	Opt.	Std.		
132	S	SH	SP						Std.	Opt.	Opt. *
132	M	MH	MP						Opt.	Std.	Opt. *
132	MA								Opt.	Opt.	Std. *
Weight		kg			2	3	5.5	7	10	16	22
		lb			4.4	6.6	12.1	15.4	22	35	49
Inertia		kg-m <sup>2</sup> x 10 <sup>-3</sup>			0.015	0.045	0.153	0.45	0.86	1.22	2.85
		lb-ft <sup>2</sup> x 10 <sup>-3</sup>			0.356	1.068	3.63	10.68	20.4	29.0	67.6



\* IP66 brake not possible  
# Manual brake release option not possible

<sup>2)</sup>When used as a stopping brake, evaluation is essential.  
<sup>3)</sup>Designed as a holding brake or emergency stop only.

Std - Standard Offering  
Opt - Optional Offering



## CAUTIONS

- **Brake torque** - The brake torque is measured with a mean friction radius of the brake pad surface with a circumferential speed of 1m/sec (197 fpm).
- **Brake torque tolerance** - For different applications and operating conditions, brake torque can vary from +40/-20% compared to the rated brake torque.
- **Hoisting (lifting/lowering) applications** - must have the brake wired for fast response (DC-switching)
- **Initial operation & wear-in period** - In new condition, the brake will have a reduced torque of up to 30%. In order to achieve full rated brake torque, a short run-in period is required. The run in time will vary depending on system loads.
- **The brake rotor or brake pad** - must be protected against foreign matter, oil and grease. Contaminants of this type can greatly influence wear and reduce braking torque.

### Brake Torque Adjustment

Brake torque adjustments are possible by changing the brake spring combinations or by removing springs.

Brake Torque Reduction - Spring Removal

"Brake Size"	7 Springs		5 Springs		3 Springs	
	[Nm]	[lb-ft]	[Nm]	[lb-ft]	[Nm]	[lb-ft]
BRE 5	5	3.7	3.5	2.6	2	1.5
BRE10	10	7.4	7	5.2	4	3.0
BRE20	20	14.8	14	10.3	8	5.9
BRE40	40	29.5	28	20.7	17	12.5
BRE60	60	44.3	43	31.7	26	19.2
BRE100	100	73.8	70	51.6	42	31.0
BRE150	150	111	107	78.9	65	47.9

When adjusting the brake torque, start by removing the outer springs at opposite corners to prevent uneven brake wear.

On brake sizes 5-150 Nm (3.7-111 lb-ft) full brake torque is achieved with all (7) springs. The brake springs are placed in such a manner where there are (3) inner and (4) outer springs.

### Spanner Nut Adjustment

"Brake Size"	Torque Reduction*		Max. Turns	Minimum Torque*	
	[Nm]	[lb-ft]		[Nm]	[lb-ft]
BRE 5	0.2	0.15	6	0.8	0.59
BRE10	0.2	0.15	12	1.6	1.18
BRE20	0.3	0.22	12	4.4	3.25
BRE40	1	0.74	9	8.0	5.90

- \* With the minimum number of springs and maximum number of turns to the spanner nut.
- \* Per each turn of the spanner nut

In addition, brake sizes from 5-40 Nm (3.7-30 lb-ft) are typically supplied with a threaded adjustment nut or spanner nut. Additional fine torque adjustment can be made by unscrewing the spanner nut a number of turns or "clicks" with a spanner wrench.





## Brake Times & Electrical Selection

Brake timing performance is critical in selecting the optimal brake system. NORD brakes can provide exceptional performance in terms of the release (start) times and engagement (stop) times. Use the following guidelines in order to select the correct brake control components and connections.

- 1) Determine if the brake needs to be wired directly from the motor terminal block or powered by a separate source.
  - If you are using a frequency inverter, soft-start or a two speed motor you will need to supply the rectifier from a separate power source.
  - If the motor is powered direct across-the-line the rectifier power can be supplied from the motor's terminal block.
- 2) What type of performance do I need?
  - Is the standard brake performance OK?
  - Is a higher performance required for fast brake release or very fast brake stopping?
- 3) Determine the brake supply voltage and check the rectifier compatibility table on 206



## Selection Suggestions

### When Fast or Very Fast Stopping is Recommended

Any applications that require quick stops and positive action at stand-still.

### Recommended Applications

- conveyors and inclined conveyors
- hoists and lifts
- bulk material handling equipment (bucket elevators, idler conveyor's).

 <b>CAUTIONS</b> 
<ul style="list-style-type: none"> <li>• <b>Hoisting (lifting/lowering) applications</b> - must have the brake wired for fast response.</li> </ul>

### When Fast-Release is Recommended (Overexcitation)

Any application that is very high-cycling with frequent starts and stops. These applications require the brake to release very-quickly in order to avoid excessive heat build-up in the AC motor and brake coil.

### Recommended Applications

- Index conveyors
- Diverters
- Storage and retrieval crane systems

Power Source	Brake Release (start)	Brake engagement (stop)	Braking Method *	Rectifier
<b>Motor Terminal Block</b>	Standard	Standard (AC switching)	10	GVE/GHE/GUE
	Standard	Fast (DC switching)	15	GVE/GHE/GUE
	Standard	Very Fast (Reduced power holding)	40	GPE/PMG
	Fast (Overexcitation)	Standard (AC switching)	30	GPE/PMG
	Fast (Overexcitation)	Fast (DC switching)	35	GPE/PMG
<b>Separate Power Source</b>	Standard	Standard (AC switching)	20	GVE/GHE/GUE
	Standard	Fast (DC switching)	25	GVE/GHE/GUE
	Standard	Very Fast (Reduced power holding)	55	GPU/PMG
	Fast (Overexcitation)	Standard (AC switching)	45	GPU/PMG
	Fast (Overexcitation)	Fast (DC switching)	50	GPU/PMG

\* Braking methods referenced in connection diagrams on pages 228 - 230

### Rectifier Styles

**GV** - Full Wave Rectifier (Bridge)

**GH** - Half Wave Rectifier

**GU** - Combo Rectifier, Can be connected full or half wave

**GPE** - Hybrid Rectifier, Full wave then switches to half wave.

**PMG** - Hybrid Rectifier, Full wave then switches to half wave.

**GPU** - Hybrid Rectifier, Full wave, then switches to half wave. Has integrated DC Switching via voltage sensing.





## Brake Rectifier Compatibility

Brake Voltage (VAC)	Coil Voltage (VDC)	Braking Method	Rectifier Type	Rectifier P/N	BRE 5	BRE 10	BRE 20	BRE 40	BRE 60	BRE 100	BRE 150	BRE 250	BRE 400	BRE 800	
115	105	20	GVE20L	19141000	X	X	X	X	X	X	X				
	105	25	GVE20L	19141000	X	X	X	X	X	X	X				
208	180	10	GVE20L	19141000	X	X	X	X	X	X	X	X	X		
	180	15	GVE20L	19141000	X	X	X	X	X	X	X	X	X		
	180	20	GVE20L	19141000	X	X	X	X	X	X	X	X	X		
	180	25	GVE20L	19141000	X	X	X	X	X	X	X	X	X		
	105	30	GPE20L	19140230	X	X	X	X							
	105	30	PMG500	19140200					X	X	X	X	X	X	
	105	35	GPE20L	19140230	X	X	X	X							
	105	35	PMG500	19140200					X	X	X	X	X	X	
	180	40	GPE20L	19140230	X	X	X	X	X	X	X				
	180	40	PMG500	19140200								X	X	X	
	105	45	GPU20L	19140090	X	X	X	X							
	105	45	PMG500	19140200					X	X	X	X	X	X	
	105	50	GPU20L	19140090	X	X	X	X							
	105	50	PMG500	19140200					X	X	X	X	X	X	
	180	55	GPU20L	19140090	X	X	X	X	X	X	X				
	180	55	PMG500	19140200									X	X	X
230	105	10	GHE40L	19141010	X	X	X	X	X	X	X				
	205	10	GVE20L	19141000	X	X	X	X	X	X	X	X	X		
	205	10	GUE40V	19140300	X	X	X	X	X	X	X				
	105	15	GHE40L	19141010	X	X	X	X	X	X	X				
	205	15	GVE20L	19141000	X	X	X	X	X	X	X	X	X		
	205	15	GUE40V	19140300	X	X	X	X	X	X	X				
	105	20	GHE40L	19141010	X	X	X	X	X	X	X				
	205	20	GUE40V	19140300	X	X	X	X	X	X	X	X	X		
	205	20	GVE20L	19141000	X	X	X	X	X	X	X				
	105	25	GHE40L	19141010	X	X	X	X	X	X	X				
	205	25	GUE40V	19140300	X	X	X	X	X	X	X	X	X		
	205	25	GVE20L	19141000	X	X	X	X	X	X	X				
	105	30	GPE20L	19140230	X	X	X	X							
	105	30	PMG500	19140200					X	X	X	X	X	X	
	105	35	GPE20L	19140230	X	X	X	X							
	105	35	PMG500	19140200					X	X	X	X	X	X	
	205	40	GPE20L	19140230	X	X	X	X	X	X	X				
	205	40	PMG500	19140200					X	X	X	X	X	X	
	105	45	GPU20L	19140090	X	X	X	X							
	105	45	PMG500	19140200					X	X	X	X	X	X	
	105	50	GPU20L	19140090	X	X	X	X							
	105	50	PMG500	19140200					X	X	X	X	X	X	
	205	55	GPU20L	19140090	X	X	X	X	X	X	X				
	205	55	PMG500	19140200									X	X	X
	205	55	GPU20	19140090	X	X	X	X	X	X	X				
	205	55	PMG500	19140200									X	X	X



### Brake Rectifier Compatibility

Brake Voltage (VAC)	Coil Voltage (VDC)	Braking Method	Rectifier Type	Rectifier P/N	BRE 5	BRE 10	BRE 20	BRE 40	BRE 60	BRE 100	BRE 150	BRE 250	BRE 400	BRE 800
332	180	30	GPE40L	19140240	X	X	X	X	X	X	X			
	180	30	PMG500	19140200								X	X	X
	180	35	GPE40L	19140240	X	X	X	X	X	X	X			
	180	35	PMG500	19140200								X	X	X
	180	45	GPU40L	19140170	X	X	X	X	X	X	X			
	180	50	GPU40L	19140170	X	X	X	X	X	X	X			
400	180	10	GHE40L	19141010	X	X	X	X	X	X	X			
	180	10	GUE40V	19140300	X	X	X	X	X	X	X			
	180	15	GHE40L	19141010	X	X	X	X	X	X	X			
	180	15	GUE40V	19140300	X	X	X	X	X	X	X			
	180	20	GHE40L	19141010	X	X	X	X	X	X	X			
	180	20	GUE40V	19140300	X	X	X	X	X	X	X			
	180	25	GHE40L	19141010	X	X	X	X	X	X	X			
	180	25	GUE40V	19140300	X	X	X	X	X	X	X			
	180	30	GPE40L	19140240	X	X	X	X	X	X	X			
	180	30	PMG500	19140200								X	X	X
	180	35	GPE40L	19140240	X	X	X	X	X	X	X			
	180	35	PMG500	19140200								X	X	X
	180	45	GPU20L	19140090	X	X	X	X	X	X	X			
	180	45	PMG500	19140200								X	X	X
	180	50	GPU20L	19140090	X	X	X	X	X	X	X			
	180	50	PMG500	19140200								X	X	X
460	205	10	GHE40L	19141010	X	X	X	X	X	X	X	X	X	
	205	10	GUE40V	19140300	X	X	X	X	X	X	X			
	205	15	GHE40L	19141010	X	X	X	X	X	X	X	X	X	
	205	15	GUE40V	19140300	X	X	X	X	X	X	X			
	205	20	GHE40L	19141010	X	X	X	X	X	X	X	X	X	
	205	20	GUE40V	19140300	X	X	X	X	X	X	X			
	205	25	GHE40L	19141010	X	X	X	X	X	X	X	X	X	
	205	25	GUE40V	19140300	X	X	X	X	X	X	X			
	205	30	GPE40L	19140240	X	X	X	X	X	X	X			
	205	30	PMG500	19140200								X	X	X
	205	35	GPE40L	19140240	X	X	X	X	X	X	X			
	205	35	PMG500	19140200								X	X	X
	205	45	GPU40L	19140170	X	X	X	X	X	X	X			
	205	45	PMG500	19140200								X	X	X
	205	50	GPU40L	19140170	X	X	X	X	X	X	X			
	205	50	PMG500	19140200								X	X	X
575	250	10	GHE50L	19141020	X	X	X	X	X	X	X	X	X	
	250	15	GHE50L	19141020	X	X	X	X	X	X	X	X	X	
	250	20	GHE50L	19141020	X	X	X	X	X	X	X	X	X	
	250	25	GHE50L	19141020	X	X	X	X	X	X	X	X	X	





## Hand Release Lever (HL)

Mod

The hand release option allows the brake to be manually released without requiring that the brake be energized with voltage. The lever has a spring return that allows the brake to be hand released and returned automatically to its set position. The hand release lever can be unscrewed for easy removal.

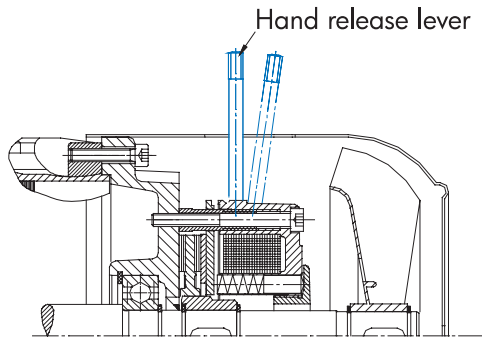

## Locking Hand Release Lever (FHL)

Mod

This option allows the brake to be manually released and locked off without requiring voltage to the brake. The lock mechanism prevents the spring from returning the brake to a closed state without manual action by the user. The hand release lever can be unscrewed for easy removal.

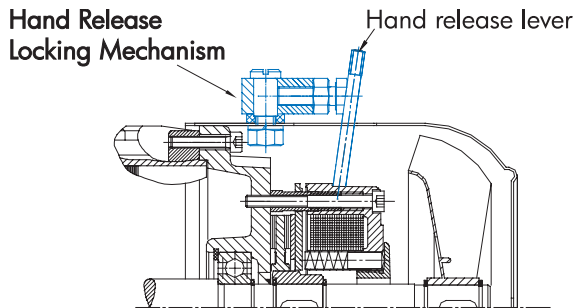

## Hand Release Lever With Hole (HLH)

Build

The hand release levers can be provided with a 5.5mm through hole. The hole can be used for attaching external pulling devices such as a cord to release the brake at a distance. This option is available for brake sizes BRE5 to BRE60.



### Hand Release Lever Location Required for HL, FHL and HLH

- Position 1
- Position 2
- Position 3
- Position 4

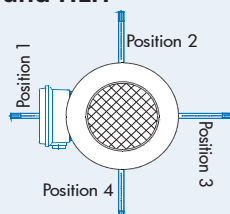

## Corrosion Protected Brake (RG)

Build

The brake is fitted with a stainless steel brake plate to provide additional corrosion protection in severe and wet environments.

## Dust & Corrosion Protected Brake (SR)

Build

A rubber-sealing boot is installed on the brake to provide additional protection in dusty environments. This feature includes the stainless steel brake plate (RG).

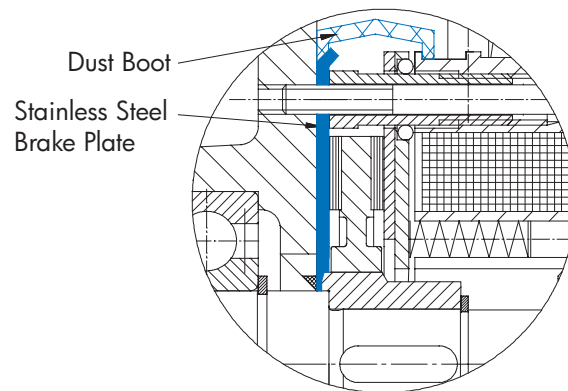

## IP66 Brake Enclosure (IP66)

Build

A sealed brake with IP66 enclosure protection can also be provided. This brake has a different mechanical housing that provides a higher degree of protection against severe environments.

## Brake Heating

Build

Brakes can be provided with a number of different heating systems. Contact NORD to discuss the details of your application





## Quiet Brake Release (NRB1)

Build

To reduce the noise of the brake release, an o-ring can be placed between the brake coil body and the armature plate (stationary disc). The o-ring dampens the impact caused by the armature plate hitting the brake coil body during the release process. When ordering NRB1, the SR (Dust Boot) option is required. The SR option also includes the RG stainless steel corrosion plate.

## Quiet Brake Motor Operation (NRB2)

Build

Noise due to vibration in the brake components is possible during motor operation particularly with variable frequency drive or single phase motor operation. To reduce this vibration the brake can be constructed with an o-ring between the brake carrier hub and the brake disc. This o-ring will prevent the clattering caused by the rapid micro speed changes in the motor caused by inverter or single phase operation.

## Micro Switch (MIK)

Build

The micro switch monitors the release state of the brake and can be wired into external control circuitry to provide additional safety. The switch can also be used to detect certain brake service problems including excessive brake wear.

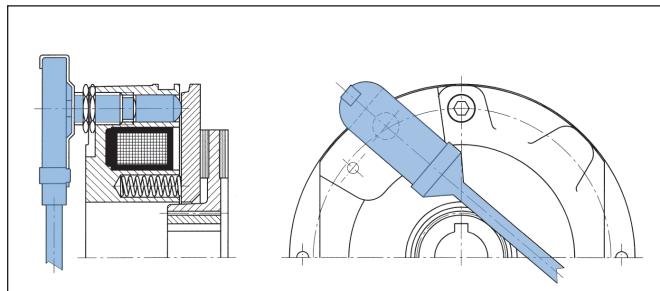

## Brass Foil (FBR)

Build

NORD brakes can be fitted with a brass foil in between the armature plate and the brake coil body. The foil acts as a magnetic resistance to weaken the brake coil's magnetic attraction to the armature plate. The weaker magnetic attraction between the armature plate and the brake coil will provide faster brake reaction (stopping) times. The brake release (start) times will be increased. The brass foil is normally used in combination with the fast GP rectifiers in over excitation mode.

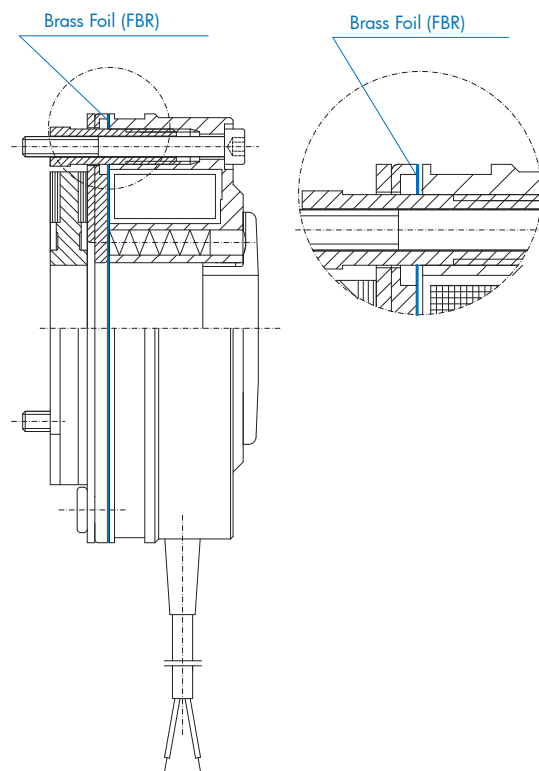
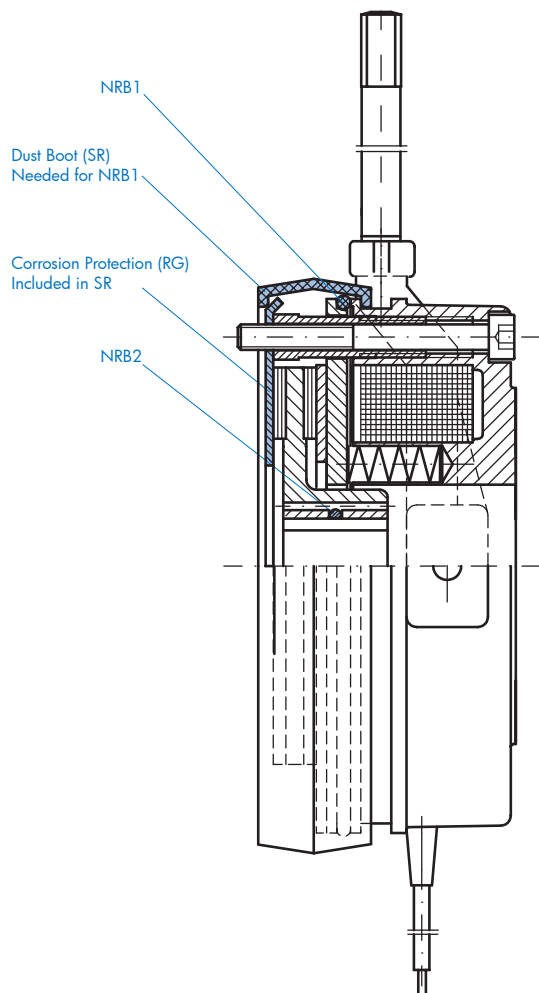



## Current Sensing Relay (IR) Mod

The current sensing relay, is used to achieve a fast brake engagement (stopping) without the use of external control equipment or additional wiring. The relay is mounted directly on the conduit box, and is powered from the motor's terminal block. The power leads for the relay replace one of the brass jumper bars on the terminal block of any single speed motor. The switch leads are connected to terminals 3 and 4 of the rectifier. When the power to the motor is shut off, the IR relay opens the brake circuit on the DC side which allows the brake to de-magnetize quickly.

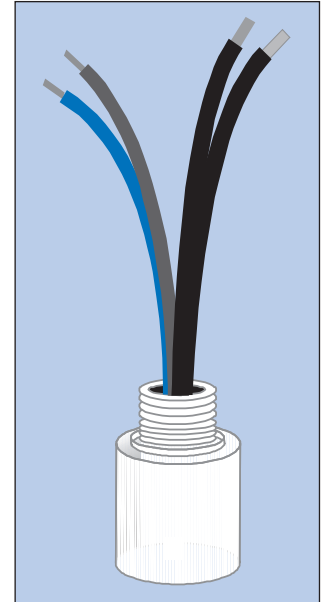

<span style="float: left;">⚠</span> <span style="font-size: 1.2em; font-weight: bold;">CAUTIONS</span> <span style="float: right;">⚠</span>	
<b>Current Sensing Relay Requirements</b>	
<ul style="list-style-type: none"> <li><span style="color: #0056b3;">■</span> Brake must be powered from the motor's terminal block (not separately powered)</li> <li><span style="color: #0056b3;">■</span> Motor must be single speed and should not be powered by a frequency inverter or soft starter.</li> </ul>	

Part number	18556010	18556020
Reissmann Part Number	RSR 25-46	RSR 50-46
Primary Current Rating (black/white wires)	25A <sub>AC</sub>	50 A <sub>AC</sub>
Maximum Primary Current (black/white wires)	75A <sub>AC</sub>	150 A <sub>AC</sub>
Maximum Time at Maximum Primary Current	0.2 s	0.2 s
Maximum Cycles per hour	500	500
Switching Voltage	42 - 550V <sub>DC</sub>	42 - 550V <sub>DC</sub>
Switching Current (red/blue wires)	1.0 A <sub>DC</sub>	1.0 A <sub>DC</sub>
Holding Current ❶	< 0.7 A <sub>AC</sub>	< 0.7 A <sub>AC</sub>
Delay Time ❷	18 ms	18 ms
Enclosure Rating	IP65	IP65
Ambient Temp.	- 25 to 90 °C (- 40 to 167 °F)	- 25 to 90 °C (- 40 to 167 °F)

- ❶ Relative to the distortion created by the magnetising current of the motor.
- ❷ Additional setting time delay added to the DC-setting time of the brake circuit.

### IR Relay Wiring Diagram

Rectifier			IR-Relay Wires to Rectifier	
Model Type	Part Number	Design	Red	Blue
GVE20L	1914000	Full-wave	4	3
GHE40L	19141010	Half-wave	4	3
GHE50L	19141020	Half-wave	4	3
GPE20L	19140230	Push-hybrid	4	3
GPE40L	19140240	Push-hybrid	4	3
GUE40V	19140300	Dual-wave	4	3

### Conduit Box Thread Adapter

Thread	Motor Frame	Part Number	O-Ring
M20	63-71	18542006*	25501615
M25	80-90	18522253	25501615
M32	100-132	18522320	25501615
M40	160	18522400 + 18522253	25501615

\* Spacer





## Double Brakes (DBR)

Build

Some applications require two independent brakes to meet industry safety guidelines.

### Double Brakes for Theatrical Applications

Many international standards for braking systems used on theatre hoists mandate the use of brakes that automatically set when power is removed. Redundancy is also required with the system brakes. If one brake fails, the other brake can still operate the system by running independently and parallel to each other. NORD DBR (2xBRE) brake systems are designed to meet these requirements. The NORD double brakes are also designed for quiet operation < 50dB(A).

Some safety standards require that the load brake hold 1.25 times the rated load at rest. We recommend selecting the brake for approximately 1.6 to a maximum of 2.0 times the required operating torque for each brake.

The NORD double theatre brakes do not need to be worn-in and will achieve their full braking torque initially.

Two brake rectifiers are required for operating a double brake systems. These will be provided as loose parts and are normally mounted in the customer's control panel.

The double brake option will add motor length compared to the single brake.



### CAUTIONS



- NORD recommends delayed operation of one of the brakes. If the brakes are operated simultaneously, the combined torques may result in excessive torque for the gear unit or other mechanical system elements. If the brakes are set at the same time even in an E-stop condition, the gear units must be sized to handle this increased torque.

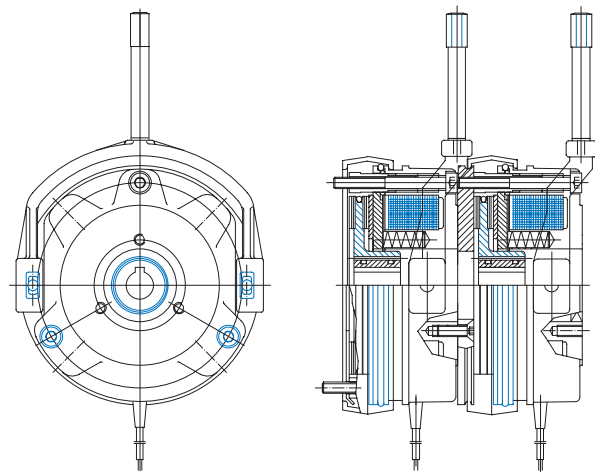

Motor	Brake	7 Springs		5 Springs		4 Springs	
		[Nm]	[lb-ft]	[Nm]	[lb-ft]	[Nm]	[lb-ft]
63S/L	DBR6	2 x 6	2 x 4.4	2 x 4	2 x 3	2 x 3.5	2 x 2.6
71S/L	DBR6	2 x 6	2 x 4.4	2 x 4	2 x 3	2 x 3.5	2 x 2.6
80S	DBR6	2 x 6	2 x 4.4	2 x 4	2 x 3	2 x 3.5	2 x 2.6
80L	DBR12	2 x 12.5	2 x 9.2	2 x 8.5	2 x 6.3	2 x 7	2 x 5.2
90S	DBR12	2 x 12.5	2 x 9.2	2 x 8.5	2 x 6.3	2 x 7	2 x 5.2
90L	DBR25	2 x 25	2 x 18.4	2 x 17.5	2 x 12.9	2 x 14	2 x 10.3
100L	DBR25	2 x 25	2 x 18.4	2 x 17.5	2 x 12.9	2 x 14	2 x 10.3
100LA/4	DBR50	2 x 50	2 x 37	2 x 35	2 x 26	2 x 28	2 x 20.7
112M	DBR50	2 x 50	2 x 37	2 x 35	2 x 26	2 x 28	2 x 20.7
132S	DBR75	2 x 75	2 x 55	2 x 52	2 x 38	2 x 42	2 x 31
132M	DBR125	2 x 125	2 x 92	2 x 89	2 x 66	2 x 70	2 x 52



## Brake Control Rectifiers

NORD brake control rectifiers convert AC voltage to DC voltage. Rectifiers are used because in many instances AC voltage is used to power the motor, but DC voltage is required to power the brake, and DC power is not typically available. NORD brakemotors typically include a rectifier that is located inside the terminal box. NORD rectifiers can be powered by the motor terminal block, or by a separate power source.

## Rectifier Advantages

- Individual power source for each brake.
- Compact size, mounted inside the terminal box.
- Multiple types, voltage options and release/engagement modes available.
- Mountable in a separate control cabinet.
- Integral protection against voltage spikes.

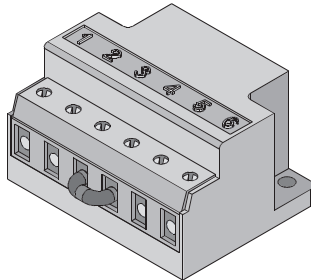

Rectifier Terminals	Description
1, 1a, 1b & 2	Brake Supply AC Voltage
3 & 4	DC-Switching Contact or Jumper
5 & 6	Connection to Brake Coil

**Rectifier Nomenclature**

**G H E 4 0 L**

- Electronic Protection**  
L = Varnish coated  
V = Encapsulated
- Voltage Range**  
20 = up to 275VAC input  
40 = up to 480VAC input  
50 = up to 575VAC input
- Type of DC Switching**  
E = External DC-switching (contact)  
U = Internal DC-switching (voltage)
- Type of Rectifier**  
H = Half-wave  
V = Full-wave (bridge)  
P = Push-Hybrid (full & half-wave)  
U = Dual (full & half-wave)
- Rectifier**

## Rectifier Protection

### Coated Electronics (G...L)

NORD standard rectifiers are provided with each brake motor (except 24 VDC brakes) unless a sealed or high performance rectifier is specified.

### Standard Rectifiers

Nomenclature	Part #	Type	Color
GVE20L	19141000	Full-wave	Black
GHE40L	19141010	Half-wave	Yellow
GHE50L	19141020	Half-wave	Grey

### Potted Electronics G...V

NORD offers rectifiers that are sealed with an electrically safe resin to ensure that water and moisture will not pass into the rectifier. Sealed rectifiers have the same brake performance ratings as the standard rectifier and can be beneficial if water is present in the motors terminal box.

### Sealed Rectifiers

Nomenclature	Part #	Type	Color
GVE20V	19141030	Full-wave	Black
GHE40V	19141040	Half-wave	Yellow
GHE50V	19141050	Half-wave	Grey
GUE40V	19140300	Full/Half-Wave	Black

## Rectifier Types

### Full-wave rectifier:

The DC output voltage is 90% of the applied input AC voltage.

### Half-wave rectifier:

The DC output voltage is 45% of the applied input AC voltage.

### Dual Rectifier (Full/Half Wave):

The GUE rectifier is a "dual" rectifier that is either a full-wave or a half-wave rectifier depending on how it is connected. An advantage for using this rectifier is when using it together with a 205 VDC brake coil, it is able to operate on either a 230 VAC or 460 VAC power connection.

### Push-Hybrid rectifier (Full/Half Wave):

These rectifiers are designed to switch from an initial full-wave mode to a final half-wave mode. They include GPE, GPU, and PMG rectifier types and are utilized to improve brake performance by providing faster stopping times or shorter brake release times.





## Stopping Methods

NORD brake rectifiers have the ability to provide different stopping performance. The different performance is achieved by using a different rectifier and/or wiring the rectifier differently. The different methods include:

- **Standard Stopping** (AC Switching)
- **Fast Stopping** (DC Switching)
- **Fast Stopping** (DC Switching via Integrated Voltage Sensing)
- **Very Fast Stopping** (Reduced Power Holding and DC Switching)
- **Very Fast Stopping** (Reduced Power Holding and DC Switching via Integrated Voltage Sensing)

### Standard Stopping (AC Switching)

The rectifier can be wired to operate by supplying and removing AC power, commonly called AC switching. The advantage to using AC switching is that the rectifier can be powered directly from the motor's terminal block and no additional wiring is required. However, tapping into the motor's terminal block gives the slower stopping time due to the de-energizing time of the motor's magnetic field. The stopping time can be improved by wiring the rectifier from an external power supply.

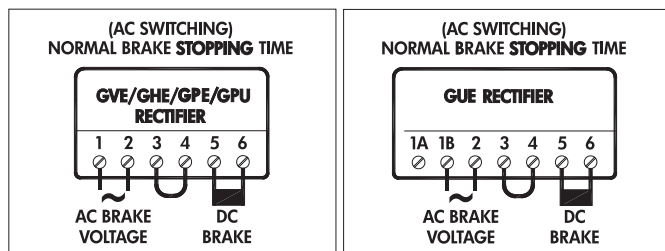

### Fast Stopping (DC switching)

DC switching directly interrupts the current flow in the DC circuit of the rectifier. This provides much faster stopping, because you do not need to wait for the motor's magnetic field to de-energize. To implement DC switching, a normally open relay must be installed between terminals 3 and 4 on the rectifier for rectifier types GVE, GHE, and GPE. For GPU type rectifiers simply remove the jumper between terminals 3 & 4 to activate DC switching.

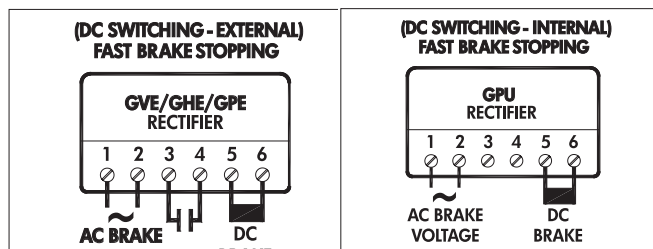

Power Source	Brake Release (start)	Brake engagement (stop)	Braking Method *	Rectifier
Motor Terminal Block	Standard	Standard (AC switching)	10	GVE or GHE
Motor Terminal Block	Fast (Overexcitation)	Standard (AC switching)	30	GPE or PMG 500
Seperate Power Source	Standard	Standard (AC switching)	20	GVE GHE or GUE
Seperate Power Source	Fast (Overexcitation)	Standard (AC switching)	45	GPU or PMG 500

\* Braking methods referenced in connection diagrams on pages 228 - 230.

Power Source	Brake Release (start)	Brake engagement (stop)	Braking Method *	Rectifier
Motor Terminal Block	Standard	Fast (DC switching)	15	GVE or GHE
	Fast (Overexcitation)	Fast (DC switching)	35	GPE or PMG 500
Seperate Power Source	Standard	Fast (DC switching)	25	GVE GHE or GUE
	Fast (Overexcitation)	Fast (DC switching)	50	GPU or PMG 500

\* Braking methods referenced in connection diagrams on pages 228 - 230.



## Fast Stopping (DC switching Via Integrated Voltage Sensing)

Our GPU rectifier's integrate DC-Switching by sensing the AC voltage supplied to the rectifier. When no voltage is present the GPU rectifier automatically opens the DC circuit. The GPU rectifier is primarily designed for use with a separate brake power source, such as inverter powered motors, soft-start motors, and two-speed motors.

The GPU rectifier is primarily designed for use with a separate brake power source, such as inverter powered motors, soft-start motors, and two-speed motors.

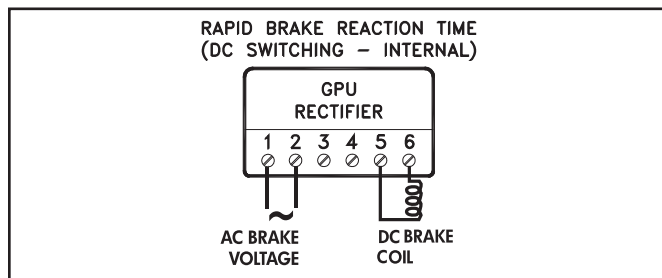

- Terminals 1 & 2 - Brake system connection to AC supply voltage
- Terminals 3 & 4 - No Jumper Connected
- Terminals 5 & 6 - DC Voltage Connection to the brake coil

Power Source	Brake Release (start)	Brake engagement (stop)	Braking Method *	Rectifier
Seperate Power Source	Fast (Overexcitation)	Fast (DC switching)	50	GPU

\* Braking methods referenced in connection diagrams on pages 228 - 230.

## Very Fast Stopping (DC switching Via Reduced Power Holding)

In reduced power holding, the rectifier initially supplies the rated DC voltage to the brake coil. When voltage is first applied, the rectifier operates as a full-wave rectifier (90% of the applied AC voltage), releasing the brake in the standard time. After the brake is released, the rectifier switches to half-wave mode (45% of the applied DC voltage), weakening the brake's magnetic field. The weaker field will allow the brake to stop more quickly when power is removed. In this method the brake coil is selected as if the brake system is powered by a full-wave rectifier. Therefore, the brake coil's DC-voltage rating should be 90% of the AC voltage applied to the rectifier.

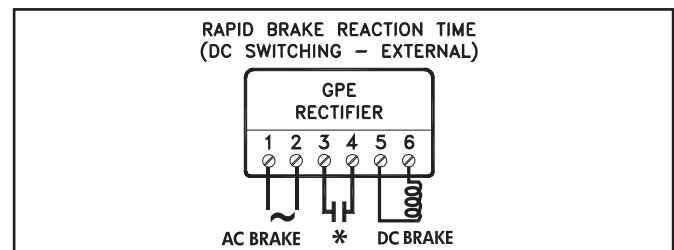

- Terminals 1 & 2 - Brake system connection to AC supply voltage
- Terminals 3 & 4 - Installed Jumper for AC switching or Switch contact (as shown) for DC switching
- Terminals 5 & 6 - DC Voltage Connection to the brake coil

\* The normally open contact/s (NO) is not supplied by NORD. It must close at the same time power is supplied to the brake. The contact must be capable of switching inductive loads and/or be rated IEC AC3.

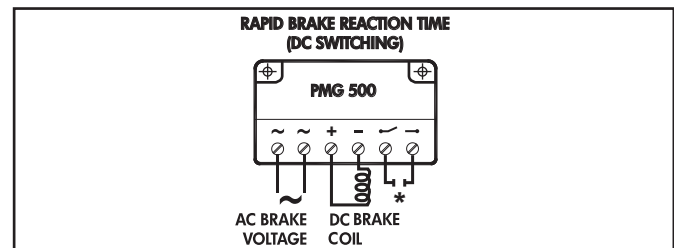

- Terminals ~ & ~ - Brake system connection to AC supply voltage
- Terminals + & - - DC Voltage Connection to the brake coil
- Terminals ~ & - - Installed Jumper for AC switching or Switch contact (as shown) for DC switching

\* The normally open contact/s (NO) is not supplied by NORD. It must close at the same time power is supplied to the brake. The contact must be capable of switching inductive loads and/or be rated IEC AC3.

Power Source	Brake Release (start)	Brake engagement (stop)	Braking Method *	Rectifier
Motor Terminal Block	Standard	Very Fast (Reduced Power Holding)	40	GPE or PMG 500
Seperate Power Source	Standard	Very Fast (Reduced Power Holding)	55	GPU or PMG 500

\* Braking methods referenced in connection diagrams on pages 228 - 230.





## Very Fast Stopping (DC switching Via Reduced Power Holding & Integrated Voltage Sensing)

In reduced power holding, the rectifier initially supplies the rated DC voltage to the brake coil. When voltage is first applied, the rectifier operates as a full-wave rectifier (90% of the applied AC voltage), releasing the brake in the standard time. After the brake is released, the rectifier switches to half-wave mode (45% of the applied DC voltage), weakening the brake's magnetic field. The weaker field will allow the brake to stop more quickly when power is removed. In this method the brake coil is selected as if the brake system is powered by a full-wave rectifier. Therefore, the brake coil's DC-voltage rating should be 90% of the AC voltage applied to the rectifier.

These GPU rectifier s integrate DC-Switching, which is triggered by sensing the AC voltage supplied to the rectifier. When no voltage is present the GPU rectifier automatically opens the DC circuit. The GPU rectifier is primarily designed for use with a separate brake power source, such as inverter powered motors, soft-start motors, and two-speed motors.

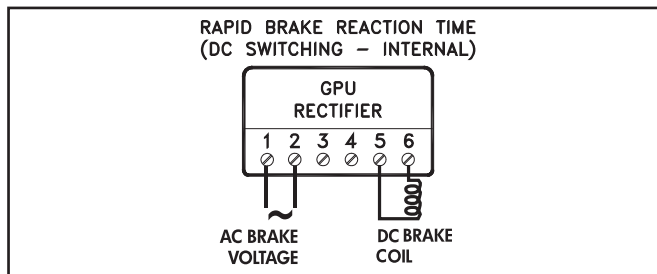

- Terminals 1 & 2** - Brake system connection to AC supply voltage
- Terminals 3 & 4** - No Jumper Connected
- Terminals 5 & 6** - DC Voltage Connection to the brake coil

Power Source	Brake Release (start)	Brake engagement (stop)	Braking Method *	Rectifier
Seperate Power Source	Standard	Very Fast (Reduced Power Holding)	55	GPU

\* Braking methods referenced in connection diagrams on pages 228 - 230.





## Release Methods (Motor Starting)

NORD brake rectifiers can provide different types of release performance. The difference in performance is achieved by using a different rectifier and/or wiring the rectifier differently. The different methods include:

- Standard Brake Release (Constant Voltage)
- Fast Brake Release (Overexcitation)

### Standard Brake Release (Constant Voltage)

For the standard brake release method the DC Brake coil is supplied by a constant rated DC voltage to magnetize the brake coil and release the brake. Typically the DC brake voltage is supplied via a brake rectifier. The brake rectifier converts AC supply voltage to DC output voltage to power the brake. NORD can supply rectifiers that are either full-wave or half-wave designs. The brake is released by supplying the rectifier with AC voltage which in turn supplies the brake coil with the needed DC voltage.

#### Example

##### *Full-Wave*

System voltage:	230 VAC
Brake coil:	205 VDC

##### *Half-Wave*

System voltage:	460 VDC
Brake coil:	205 VDC

### Fast Brake Release (Overexcitation)

In overexcitation the rectifier initially over-voltages the brake coil. This overexcitation of the rectifier produces a magnetic field in the brake coil that is stronger than normal, releasing the brake much more quickly. The rectifier is then switched over to a lower holding voltage so as not to thermally overload the brake coil. In this method the brake coil is selected as if the brake system is powered by a half-wave rectifier. Therefore, the brake coil's DC-voltage rating should be 45% of the AC voltage applied to the rectifier. This type of brake control is also called "Voltage Forcing" and "Supercharging."

#### Example

System voltage:	230 VAC
Brake coil:	105 VDC
Initial brake release voltage:	205 VDC
Holding brake voltage:	105 VDC





# Full-Wave Rectifiers (GVE)



## Full-Wave Rectifiers (GVE)

Our Full-Wave rectifiers' DC output voltage is 90% of the applied input AC voltage.

### GVE Rectifier Dimensions

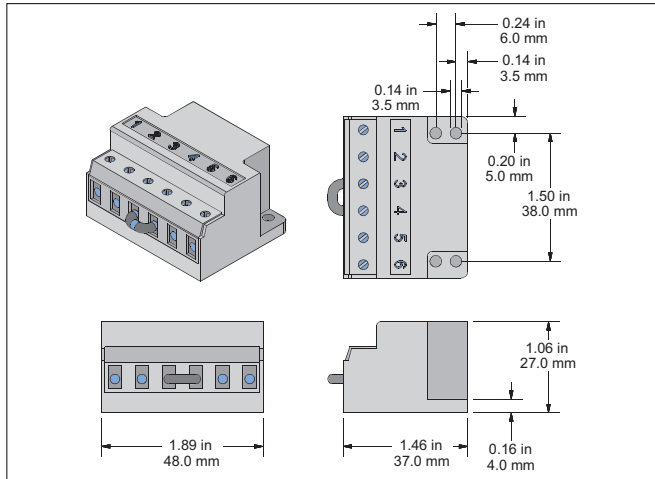

### IMPORTANT NOTE



If the motor is connected to a frequency inverter, soft start, or is a two-speed motor, the AC power must be supplied to the brake rectifier separately from the motor power.

### Ratings & Part Numbers

Model Type	GVE20L	GVE20V
Part Number	19141000	19141030
Protection (electronics)	Coated	Encapsulated
Color	Black	
Input Voltage ( $V_{AC}$ )	110-275 +/- 10% $V_{AC}$	
Output Voltage ( $V_{DC}$ )	$(V_{DC} = 0.90 \times V_{AC})$	
Rated Current @ 40°C	1.5 A	
Rated Current @ 75°C	1.0 A	
Temperature Range	-20 °C to 75 °C	
DC-Switching via	External Contact or IR Relay	

## Braking Method

Braking Method	Break Release (Start)	Brake Engage (Stop)	Power Source
10	Standard	Standard (AC-Switching)	Motor terminals
15	Standard	Fast (DC-switching)	Motor terminals
20	Standard	Standard (AC-Switching)	Separate power
25	Standard	Fast (DC-switching)	Separate power

## Basic Connection (AC & DC Switching)

The GVE brake system can be connected for standard stopping (AC-Switching) or fast stopping (DC-Switching).

### STANDARD STOPPING AC-SWITCHING

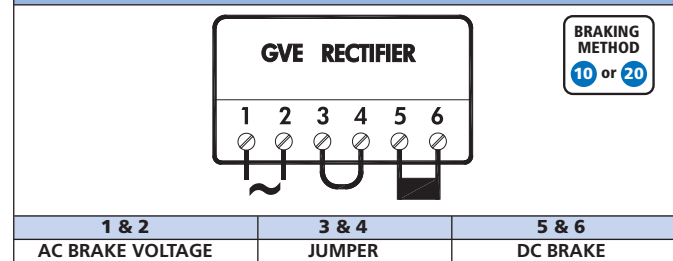

### FAST STOPPING DC-SWITCHING

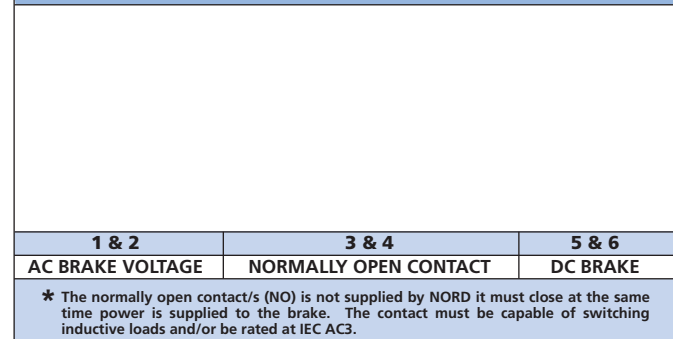

BRAKES





## Half-Wave Rectifiers (GHE)

Our Half-Wave rectifiers' DC output voltage is 45% of the applied input AC voltage.

### GHE Rectifier Dimensions

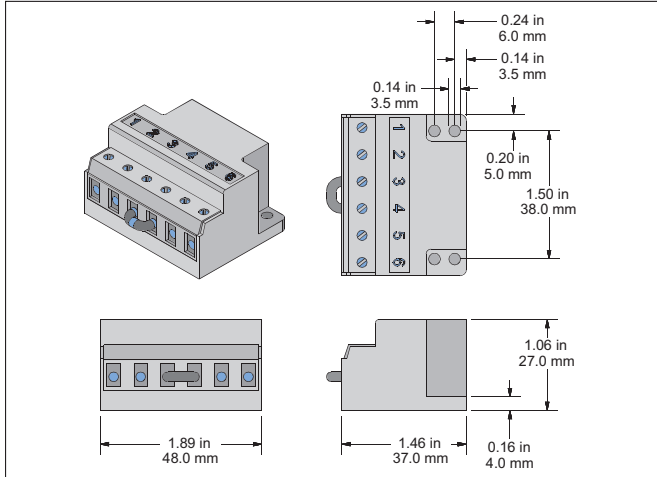

### IMPORTANT NOTE



If the motor is connected to a frequency inverter, soft start, or is a two-speed motor, the AC power must be supplied to the brake rectifier separately from the motor power.

### Ratings & Part Numbers

Model Type	GHE40L	GHE40V
Part Number	19141010	19141040
Protection (electronics)	Coated	Encapsulated
Color	Yellow	
Input Voltage ( $V_{AC}$ )	200-480 $V_{AC}$ $\pm$ 10%	
Output Voltage ( $V_{DC}$ )	$(V_{DC}=0.45 \times V_{AC})$	
Rated Current @ 40°C	2.0 $A_{DC}$	
Rated Current at 75°C	1.0 $A_{DC}$	
Temperature Range	-20°C to 75°C	
DC-Switching via	External Contact	

Model Type	GHE50L	GHE50V
Part Number	19141020	19141050
Protection (electronics)	Coated	Encapsulated
Color	Grey	
Input Voltage ( $V_{AC}$ )	200-575 $V_{AC}$ $\pm$ 10%	
Output Voltage ( $V_{DC}$ )	$(V_{DC}=0.45 \times V_{AC})$	
Rated Current @ 40°C	2.0 $A_{DC}$	
Rated Current @ 75°C	1.0 $A_{DC}$	
Temperature Range	-20°C to 75°C	
DC-Switching via	External Contact or IR Relay	

### Braking Method

Braking Method	Break Release (Start)	Brake Engage (Stop)	Power Source
10	Standard	Standard (AC-Switching)	Motor terminals
15	Standard	Fast (DC-switching)	Motor terminals
20	Standard	Standard (AC-Switching)	Separate power
25	Standard	Fast (DC-switching)	Separate power

### Basic Connection (AC & DC Switching)

The GVE brake system can be connected for standard stopping (AC-Switching) or fast stopping (DC-Switching)

### STANDARD STOPPING AC-SWITCHING

**GHE RECTIFIER**

**BRAKING METHOD**  
10 or 20

1 & 2	3 & 4	5 & 6
AC BRAKE VOLTAGE	JUMPER	DC BRAKE

### FAST STOPPING DC-SWITCHING

1 & 2	3 & 4	5 & 6
AC BRAKE VOLTAGE	NORMALLY OPEN CONTACT	DC BRAKE

\* The normally open contact/s (NO) is not supplied by NORD it must close at the same time power is supplied to the brake. The contact must be capable of switching inductive loads and/or be rated at IEC AC3.



# Dual-Wave Rectifiers (GUE)



## Dual-Wave Rectifiers (GUE)

The GUE rectifier is a “dual” rectifier that is either a full-wave or a half-wave rectifier depending on how it is connected. An advantage for using this rectifier is when using it together with a 205VDC brake coil, it is able to operate on either a 230 VAC or 460VAC power connection.

## GUE Rectifier Dimensions

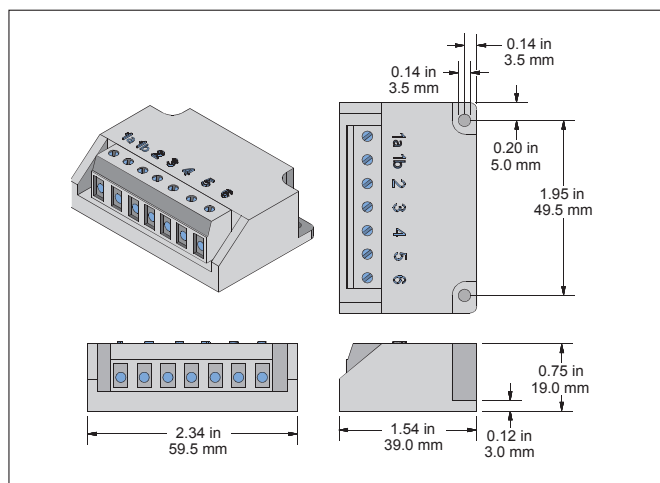

### IMPORTANT NOTE



If the motor is connected to a frequency inverter, soft start, or is a two-speed motor, the AC power must be supplied to the brake rectifier separately from the motor power.

## Ratings & Part Numbers

Model Type	GUE40V	
Part Number	19140300	
Protection (electronics)	Coated	
Color	Black	
Input Voltage (V <sub>AC</sub> )	190-230 V <sub>AC</sub> +/- 10%	380/460 V <sub>AC</sub> +/- 10%
Output Voltage (V <sub>DC</sub> )	(V <sub>DC</sub> = 0.90 x V <sub>AC</sub> ) As Full-Wave	(V <sub>DC</sub> = 0.45 x V <sub>AC</sub> ) As Half-Wave
Rated Current @ 40°C	0.7 A	
Rated Current @ 75°C	0.5 A	
Temperature Range	-20°C to 75°C	
DC-Switching via	External Contact or IR Relay	

## Braking Method

Braking Method	Break Release (Start)	Brake Engage (Stop)	Power Source
10	Standard	Standard (AC-Switching)	Motor terminals
15	Standard	Fast (DC-switching)	Motor terminals
20	Standard	Standard (AC-Switching)	Separate power
25	Standard	Fast (DC-switching)	Separate power

## Basic Connection (AC & DC Switching)

The GUE brake system can be connected for standard stopping (AC-Switching) or fast stopping (DC-Switching)

### STANDARD STOPPING AC-SWITCHING

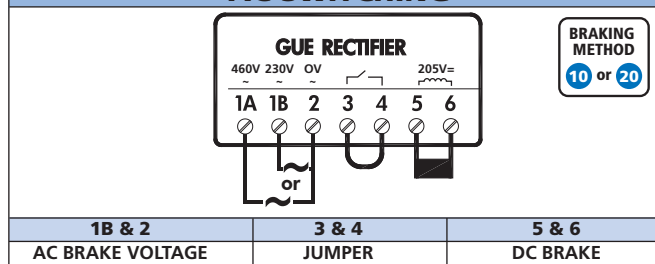

### FAST STOPPING DC-SWITCHING

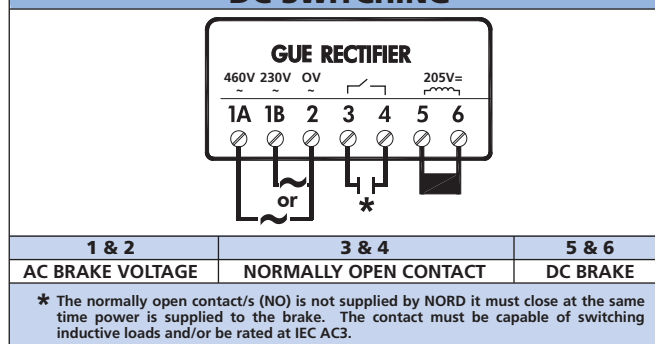

BRAKES



## Push-Hybrid Rectifiers External DC Switching (GPE)

Like the standard NORD brake control rectifiers, NORD's fast acting brake control rectifiers convert AC voltage to DC voltage. The "Fast Acting Brake Rectifiers" are utilized to improve brake performance and are often recommended in order to provide shorter brake release times or to provide faster stopping times.

The fast acting rectifiers are a two-stage "push" design. When power is first applied these rectifiers operate like a full-wave rectifier and then after a relatively short period of time they act like a half-wave rectifier. The GPE type rectifiers start out in full-wave mode when power is first applied and then after approximately 250 ms they switch to half-wave mode.

GPE rectifiers were designed for external control of the brake's DC-switching. GPE rectifiers are primarily used in across-the-line applications where the brake power is supplied by the motor terminals, but they may also be used in situations where the brake power is supplied separately to the brake rectifier.

There are two ways to apply the fast acting rectifiers:

- The first method, known as "Overexcitation," provides fast brake release. The brake coil is selected like a half-wave system (45% of the AC supply voltage).
- The second method, known as "Reduced Power Holding," provides very fast brake stopping. The brake coil is selected like a full-wave system (90% of the AC supply voltage).



### IMPORTANT NOTE



If the motor is connected to a frequency inverter, soft start, or a two-speed motor, then separate AC power must be supplied to the brake rectifier.

## GPE Rectifier Dimensions

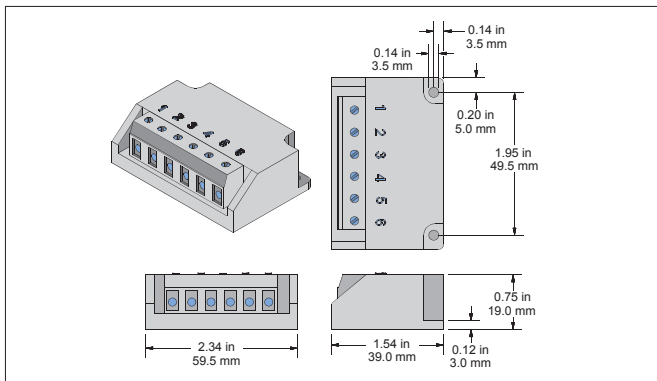

## Ratings & Part Numbers

Model Type	GPE20L	GPE40L
Part Number	19140230	19140240
Protection (electronics)	Coated	Coated
Color	Black	
Input Voltage (V <sub>AC</sub> )	200V-275V	380V-480V
Output Voltage (V <sub>DC</sub> )	(V <sub>DC</sub> =0.45 x V <sub>AC</sub> ) - As Half-Wave (V <sub>DC</sub> =0.90 x V <sub>AC</sub> ) - As Full-Wave	
Rated Current @ 40°C	0.7 A	0.7 A
Rated Current @ 75°C	0.5 A	0.5 A
Temperature Range	-20°C to 75°C	
DC-Switching via	External Contact or IR Relay	

## Braking Method

Braking Method	Break Release (Start)	Brake Engage (Stop)	Power Source
40	Standard	Very Fast (Reduced Power Holding)	Motor terminals
30	Fast (Overexcitation)	Standard (AC Switching)	Motor terminals
35	Fast (Overexcitation)	Fast (DC Switching)	Motor terminals

## Basic Connection (AC & DC Switching)

The GPE brake system can be connected for standard stopping (AC-Switching), fast stopping (DC-Switching) and very fast stopping (Reduced power holding & DC-Switching). Fast brake release can also be achieved by selecting a different brake coil combination.



### STANDARD STOPPING (AC-SWITCHING)

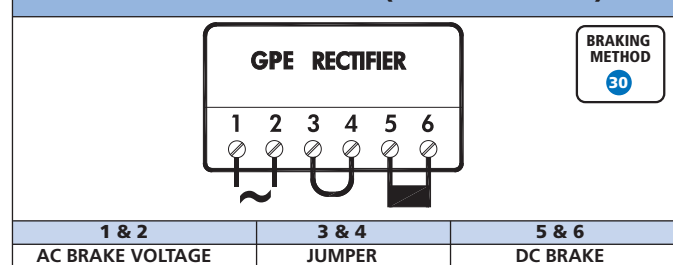

### FAST & VERY FAST STOPPING (DC-SWITCHING)

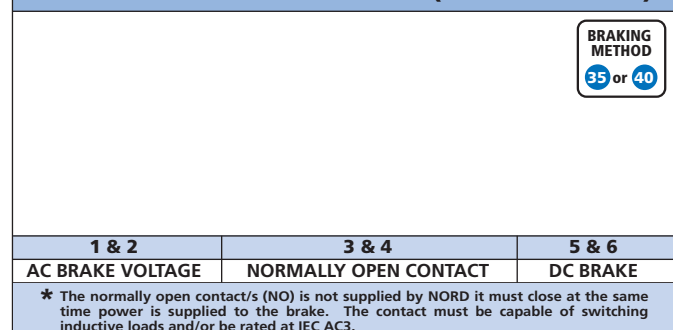

# Push-Hybrid Rectifiers External DC Switching (PMG)



## Push-Hybrid Rectifiers External DC Switching (PMG)

Like the standard NORD brake control rectifiers, NORD's fast acting brake control rectifiers convert AC voltage to DC voltage. The "Fast Acting Brake Rectifiers" are utilized to improve brake performance and are often recommended in order to provide shorter brake release times or to provide faster stopping times.

The fast acting rectifiers are a two-stage "push" design. When power is first applied these rectifiers operate like a full-wave rectifier and then after a relatively short period of time they act like a half-wave rectifier. The PMG type rectifiers start out in full-wave mode when power is first applied and then after approximately 250 ms they switch to half-wave mode.

PMG rectifiers were designed for external control of the brake's DC-switching. PMG rectifiers are primarily used in across-the-line applications where the brake power is supplied by the motor terminals, but they may also be used in situations where the brake power is supplied separately to the brake rectifier.

There are two ways to apply the fast acting rectifiers:

- The first method, known as "Overexcitation," provides fast brake release. The brake coil is selected like a half-wave system (45% of the AC supply voltage).
- The second method, known as "Reduced Power Holding," provides very fast brake stopping. The brake coil is selected like a full-wave system (90% of the AC supply voltage).

BRAKES

## Ratings & Part Numbers

Model Type	PMG 500
Part Number	19140200
Protection (electronics)	Coated
Color	Black
Input Voltage (V <sub>AC</sub> )	200-500V <sub>AC</sub> ±10%
Output Voltage (V <sub>DC</sub> )	(V <sub>DC</sub> =0.45 x V <sub>AC</sub> ) - As Half-Wave (V <sub>DC</sub> =0.90 x V <sub>AC</sub> ) - As Full-Wave
Rated Current @ 40°C	4.0 A
Rated Current @ 75°C	2.8 A
Temperature Range	-15°C to 80°C
DC-Switching via	External Contact

## Braking Method

Braking Method	Break Release (Start)	Brake Engage (Stop)	Power Source
40	Standard	Very Fast (Reduced Power Holding)	Motor terminals
30	Fast (Overexcitation)	Standard (AC Switching)	Motor terminals
35	Fast (Overexcitation)	Fast (DC Switching)	Motor terminals
55	Standard	Very Fast (Reduced Power Holding)	Separate power
45	Fast (Overexcitation)	Standard (AC Switching)	Separate power
50	Fast (Overexcitation)	Fast (DC Switching)	Separate power

## Basic Connection (AC & DC Switching)

The PMG brake system can be connected for standard stopping (AC-Switching), fast stopping (DC-Switching) and very fast stopping (Reduced power holding & DC-Switching). Fast brake release can also be achieved by selecting a different brake coil combination.

**i**
IMPORTANT NOTE
**i**

If the motor is connected to a frequency inverter, soft start, or a two-speed motor, then separate AC power must be supplied to the brake rectifier.

## PMG Rectifier Dimensions

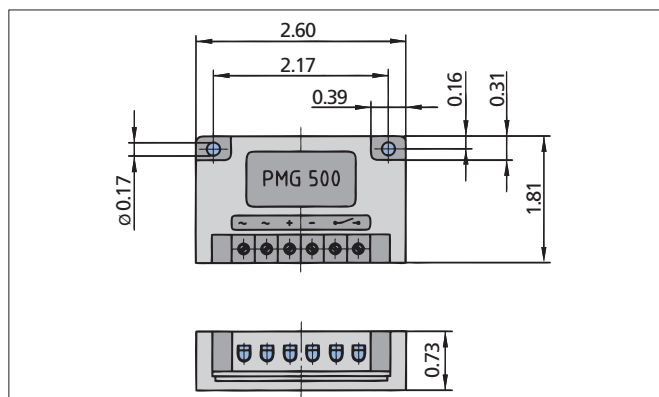

### STANDARD STOPPING (AC-SWITCHING)

**BRAKING METHOD**  
30 or 45

~ & ~	+ & -	↔ & ↔
AC BRAKE VOLTAGE	DC BRAKE	JUMPER

### FAST & VERY FAST STOPPING (DC-SWITCHING)

**BRAKING METHOD**  
35 or 40  
50 or 55

~ & ~	+ & -	↔ & ↔
AC BRAKE VOLTAGE	DC BRAKE	NORMALLY OPEN CONTACT

\* The normally open contact/s (NO) is not supplied by NORD it must close at the same time power is supplied to the brake. The contact must be capable of switching inductive loads and/or be rated at IEC AC3.



## Push-Hybrid Rectifiers Integrated DC Switching (GPU)

Like the standard NORD brake control rectifiers, NORD's fast acting brake control rectifiers convert AC voltage to DC voltage. The "Fast Acting Brake Rectifiers" are utilized to improve brake performance and are often recommended in order to provide shorter brake release times or to provide faster stopping times.

The fast acting rectifiers are a two-stage "push" design. When power is first applied these rectifiers operate like a full-wave rectifier and then after a relatively short period of time they act like a half-wave rectifier. The GPU rectifiers start out in full-wave mode when power is first applied and then after approximately 250 ms they switch to half-wave mode.

GPU rectifiers were designed for integrated control of the brake's DC-switching and voltage sensing. GPU rectifiers are primarily used in applications where there is a frequency inverter, soft-start, or two-speed motor. Separate AC power must be supplied to the brake rectifier.

There are two ways to apply the fast acting rectifiers:

- The first method, known as "Overexcitation," provides fast brake release. The brake coil is selected like a half-wave system (45% of the AC supply voltage).
- The second method, known as "Reduced Power Holding," provides very fast brake stopping. The brake coil is selected like a full-wave system (90% of the AC supply voltage).

### **IMPORTANT NOTE**

The GPU rectifier may also be utilized for across-the-line applications; however it must always be powered separate from the motor and have its own pair of contactors or starters. It is unadvisable to use the motor terminal block to supply the GPU rectifier's AC power due to the motor's slow energy dissipation when switched off.

### **IMPORTANT NOTE**

If the motor is connected to a frequency inverter, soft start, or a two-speed motor, then separate AC power must be supplied to the brake rectifier.

### Braking Method

Braking Method	Break Release (Start)	Brake Engage (Stop)	Power Source
55	Standard	Very Fast (Reduced Power Holding)	Separate power
45	Fast (Overexcitation)	Standard (AC Switching)	Separate power
50	Fast (Overexcitation)	Fast (DC Switching)	Separate power

## GPU Rectifier Dimensions

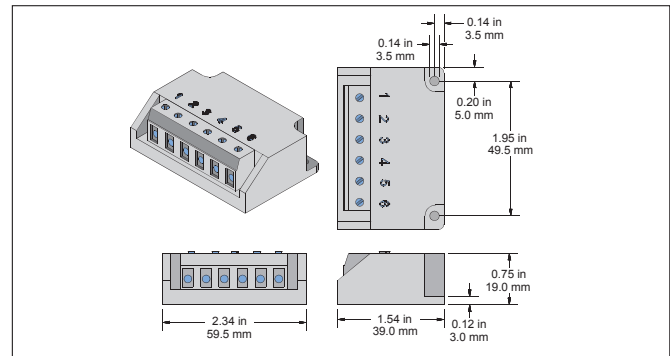

## Ratings & Part Numbers

Model Type	GPU20L	GPU40L
Part Number	19140090	19140170
Protection (electronics)	Coated	Coated
Color	Black	
Input Voltage (V <sub>AC</sub> )	200V-275V	380V-480V
Output Voltage (V <sub>DC</sub> )	(V <sub>DC</sub> =0.45 x V <sub>AC</sub> ) - As Half-Wave (V <sub>DC</sub> =0.90 x V <sub>AC</sub> ) - As Full-Wave	
Rated Current @ 40°C	0.7A	0.7 A
Rated Current @ 75°C	0.5A	0.5A
Temperature Range	-20°C to 75°C	
DC-Switching via	Internal Activation	

## Basic Connection (AC & DC Switching)

The GPU brake system can be connected for standard stopping (AC-Switching), fast stopping (DC-Switching) and very fast stopping (Reduced power holding & DC-Switching). Fast brake release can also be achieved by selecting a different brake coil combination.

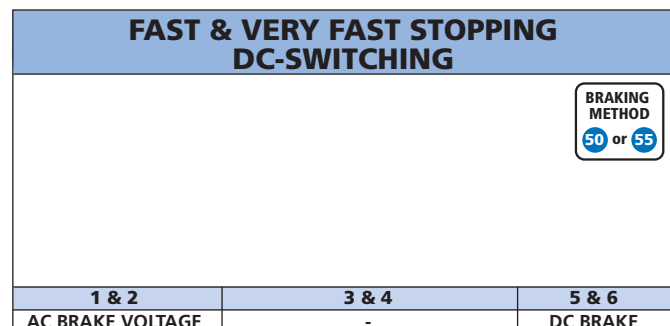
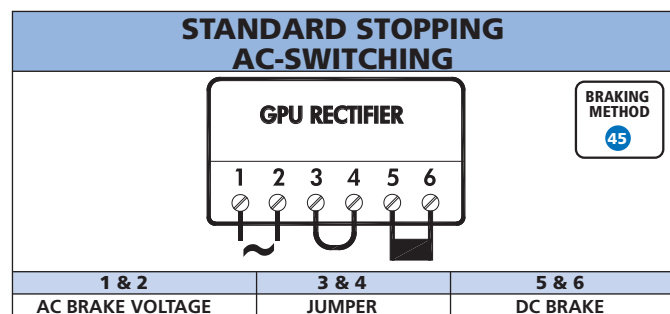



# Digital Input Dual Wave Rectifiers (EBGR)



## Digital Input Activated Dual Full & Half Wave Rectifiers (EBGR)

The EBGR-1 provides brake control by an internal 24VDC signal or contact closure. This allows the motor brake to be easily operated by an external controller like a PLC or an AC drive without the need for a piloting relay. The rectifier can be connected as either a full-wave or half-wave brake power source, similar to the GUE rectifier. The EBGR module also provides status notification to an external device like a PLC. The device is designed for DIN rail mounting.

The module must be supplied with 24VDC power connected to terminal 44 and control ground to terminal 40 for proper operation. The terminals 44 and 40 are bridged to terminal 44 and 40 on the opposite side of the rectifier. This power is the source for the digital output used as an acknowledgement to a supervisory device (PLC or Drive). The digital input controls both the on/off state of the brake coil power, acknowledging the digital output. In the event that the brake coil becomes detached the acknowledgement will not function, indicating a problem with the brake or wiring.

## Braking Method

Braking Method	Break Release (Start)	Brake engage (Stop)	Power source
25	Standard	Fast (DC-switching)	Separate power

## Basic Connection

The EBGR rectifiers have integrated DC-switching to allow for fast brake engagement.

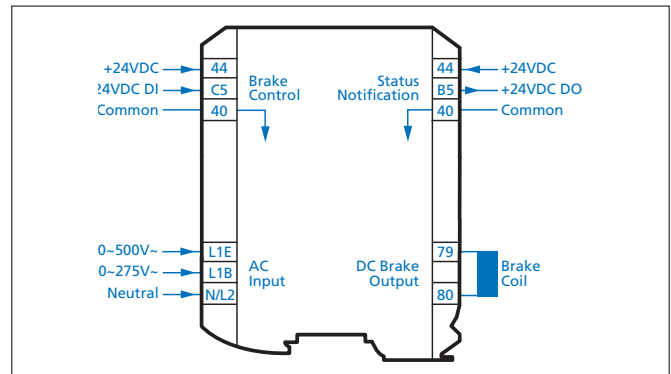

## EBGR Rectifier Dimensions

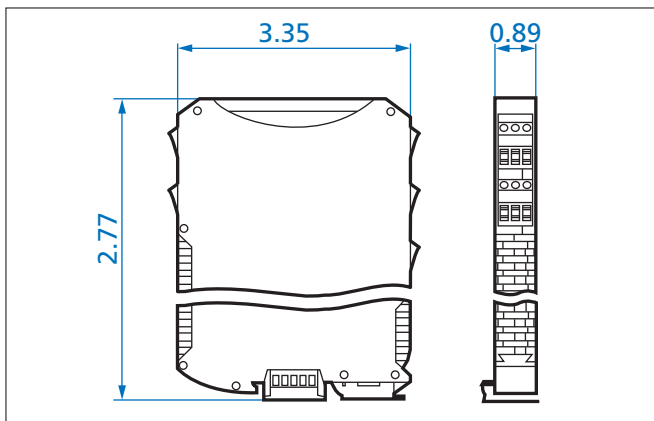

## Ratings & Part Numbers

Model Type	EBGR
Part Number	19140990
Protection (electronics)	IP20
Input Voltage ( $V_{AC}$ )	100-275V $\pm$ 10% (Terminal L1B & N/L2)
	380 - 500V $\pm$ 10% (Terminal L1E & N/L2)
Output Voltage ( $V_{DC}$ )	( $V_{DC}=0.90 \times V_{AC}$ ) (Full-Wave)
	( $V_{DC}=0.45 \times V_{AC}$ ) (Half Wave)
Rated Current @ 40°C	0.7A
Rated Current @ 75°C	0.5A
Temperature Range	-20°C to 75°C
DC-Switching	Integrated

Description	Terminal	Position Description
24VDC power supply input bridged to output	44	1 Top Layer
Digital input used to control DC brake coil	C5	
Common reference signal ground DC	40	
AC main power Half-wave rectifier input 380-500VAC	L1E	2 Top Layer
AC main power Full-wave rectifier input 100-275VAC	L1B	
Neutral or line 2 common AC connection	N/L2	
Common 24VDC power supply from input side	44	3 Bottom Layer
Digital output DC brake coil status	B5	
Common DC reference signal ground	40	4 Bottom Layer
DC brake coil connection Plus +	79	
No connect	-	
DC brake coil connection minus -	80	

**CAUTION**

Be sure not to connect higher voltage AC mains to the DC rated terminals as this will result in damage to the unit. AC terminals include numbers and the DC terminals are all numbers only. Follow UL standards for protection.

Terminals	Screw type	Terminal blocks
Cable cross section	0.2 to 2.5mm	12-30 AWG
PE connection	Grounded through DIN rail	Snap on rail must be grounded.

Main Line Voltage	Brake Coil Voltage	Terminal Number
230 VAC	205 VDC	L1B + N/L2
400 VAC	180 VDC	L1E + N/L2
460 VAC	205 VDC	L1E + N/L2



## Standard Brake Components

Standard brake components will be provided if no brake components are specified by the customer.

### Motor Voltage 230/460V-60Hz (208-230/460V) (YY/Y)

Brake Sizes	BRE5-BRE400	BRE800-BRE1200
Brake Coil Voltage	205VDC	No standard – must be specified
Rectifier	GVE20L – full-wave	PMG500
Brake AC Supply	230VAC	No standard – must be specified

**Notes** – The 230VAC standard brake can be used on either motor voltage connection (230V or 460V) when the motor is powered directly with line power and the brake voltage is provided by the motor terminals. When the brake is separately powered, like inverter operation, the brake AC voltage should match the motor connected voltage 230VAC or 460VAC. A 460VAC brake requires a different rectifier to be specified.

### Motor Voltage 460/800V-60Hz (Δ/Y)

Brake Sizes	BRE5-BRE400	BRE800-BRE1200
Brake Coil Voltage	205VDC	205VDC
Rectifier	GHE40L – half-wave	PMG500
Brake AC Supply	460VAC	460VAC

### Motor Voltage 332/575V-60Hz (Δ/Y)

Brake Sizes	BRE5-BRE400	BRE400-BRE1200
Brake Coil Voltage	250VDC	No standard – must be specified
Rectifier	GHE50L – half-wave	No standard – must be specified
Brake AC Supply	575VAC	No standard – must be specified

### Motor Voltage 208/360V-60Hz (Δ/Y)

Brake Sizes	BRE5-BRE400	BRE800-BRE1200
Brake Coil Voltage	180VDC	No standard – must be specified
Rectifier	GVE20L – full-wave	PMG500
Brake AC Supply	208VAC	No standard – must be specified

### Motor Voltage 230/400V-50Hz (220-240/380-420V) (Δ/Y)

Brake Sizes	BRE5-BRE400	BRE800-BRE1200
Brake Coil Voltage	205VDC	No standard – must be specified
Rectifier	GVE20L – full-wave	PMG500
Brake AC Supply	230VAC	No standard – must be specified

### Motor Voltage 400/690-50Hz (380-420/660-720V) (Δ/Y)

Brake Sizes	BRE5-BRE400	BRE800-BRE1200
Brake Coil Voltage	180VDC	No standard – must be specified
Rectifier	GHE40L – half-wave	No standard – must be specified
Brake AC Supply	400VAC	No standard – must be specified





# Brake Performance Data



## Brake Performance Data

Brake Size		BRE5	BRE10	BRE20	BRE40	BRE60	BRE100	BRE150
Brake torque $-_{max}$	[lb-ft]	3.7	7.4	15	30	44	74	110
	[lb-in]	44	89	177	354	531	885	1330
	[Nm]	5	10	20	40	60	100	150
Power coil $P_{20}$	[W]	22	28	39	42	50	75	76
Nominal air gap	[in]	0.008	0.008	0.008	0.012	0.012	0.016	0.020
	[mm]	0.2	0.2	0.2	0.3	0.3	0.4	0.5
Maximum air gap (re-adjust) $a_{max}$	[in]	0.024	0.013	n/a	0.035	0.039	0.043	0.043
	[mm]	0.6	0.8	n/a	0.9	1.0	1.1	1.1
Max brake pad wear - must be replaced	[in]	0.118	0.118	0.039	0.118	0.138	0.138	0.138
	[mm]	3	3	1	3	3.5	3.5	3.5
Minimum brake pad thickness	[in]	0.177	0.217	0.295	0.374	0.453	0.492	0.571
	[mm]	4.5	5.5	7.5	9.5	11.5	12.5	14.5
Max work per cycle $W_{max}$	[Jx10 <sup>3</sup> ]	3	6	12	25	35	50	75
Work until re-adjust $W_m$	[Jx10 <sup>7</sup> ]	5	12	20	35	60	125	200
Heat load per cycle	[J/s]	80	100	130	160	200	250	300
Release time (start) $t_1$	[ms]	35	45	70	80	120	160	200
Release time (start) $t_{1-OE}$	[ms]	15	15	28	28	75	110	110
Setting time (stop) $t_{2-AC}$	[ms]	70	95	140	175	210	280	350
Setting time (stop) $t_{2-DC}$	[ms]	30	45	30	75	90	120	150
Setting time (stop) $t_{2-DCRP}$	[ms]	5	6	11	12	12	13	17
IR relay delay (stop) $t_{2-IR}$	[ms]	18	18	18	18	18	18	18
Current – 250VDC coil	[A]	0.09	0.11	0.16	0.18	0.19	0.31	0.31
Current – 225VDC coil	[A]	0.09	0.13	0.18	0.20	0.22	0.35	0.36
Current – 205VDC coil	[A]	0.11	0.13	0.22	0.24	0.28	0.44	0.45
Current – 180VDC coil	[A]	0.12	0.16	0.21	0.25	0.30	0.46	0.47
Current – 105VDC coil	[A]	0.21	0.32	0.36	0.46	0.60	0.88	0.89
Current – 24VDC coil	[A]	0.92	1.17	1.63	1.75	2.08	3.10	3.20

### Release times

$t_1$  – Brake release time - Standard

$t_{1-OE}$  – Brake release time – Overexcitation (GP)

### Set (stop) times

$t_{2-AC}$  – Brake set time – AC switching

$t_{2-DC}$  – Brake set time – DC switching

$t_{2-DCRP}$  – Brake set time – DC switching reduced power

$t_{2-IR}$  – Additional brake stopping of the IR relay

An increased air gap will alter the braking times.



## Brake Size Calculation

Torque and inertias below are based on the motor speed. Load side torques must always be divided by the gear reduction ratio. Inertias must be divided by the *square* of the gear ratio. You must also consider any external reduction ratio outside the gearbox.

### Selection for holding loads (static)

$$T_{req} = T_{stat} = T_{load} \times K$$

### Selection for stopping loads (static + dynamic)

$$\sum J = J_{motor} + \frac{J_{load}}{i^2}$$

Typically other inertias, like the gearbox, can be ignored.

$$T_{dyn} = \frac{\sum J \times n}{25.7 \times t_r}$$

$$T_{req} = (T_{dyn} \pm T_{load}) \times K$$

For driving loads use:  $-T_{load}$   
 For overhauling loads use:  $+T_{load}$

## Brake Work Verification

$$W = \frac{\sum J \times n^2}{5880} \times \frac{T_B}{T_B \pm T_{load}} \Rightarrow W \leq W_{max}$$

For driving loads use:  $+T_{load}$   
 For overhauling loads use:  $-T_{load}$

The permissible values for  $W_{max}$  (Friction work) depend on the stopping frequency. See diagram at right.

In applications where the brake is operated frequently, two brake work values should be evaluated to ensure adequate brake life: the braking work compared to the braking frequency and the maximum work limit for a single operation, such as an E-stop. Reviewing these two values will help determine the optimal solution and ensure long brake life.

## Abbreviation Key

c/h	=	Number of brakes per hour
J [lb-ft <sup>2</sup> ]	=	Inertia
J <sub>motor</sub> [lb-ft <sup>2</sup> ]	=	Motor inertia
i	=	System reduction ratio
K	=	Safety factors. Based on application and according to industry rules and practices Hoisting >2 Hoisting with people >2..3 Travel drives 0.5 to 1.5
T <sub>B</sub> [lb-in]	=	Brake torque
T <sub>dyn</sub> [lb-in]	=	Dynamic torque
T <sub>req</sub> [lb-in]	=	Required brake torque
T <sub>load</sub> [lb-in]	=	Load torque
T <sub>stat</sub> [lb-in]	=	Static torque
n [rpm]	=	Motor speed
t <sub>r</sub> [sec]	=	Stopping time
W [J]	=	Brake work
W <sub>max</sub> [J]	=	Maximum brake work for one brake operations

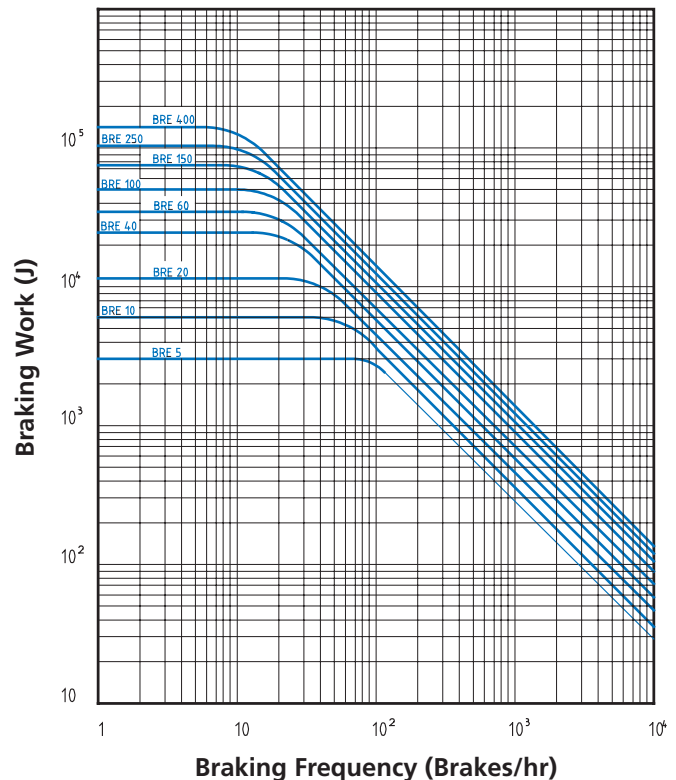







## GUE Dual Rectifier - Connection Diagrams

GU101A		GU101B		GU103A		GU103B			
POWERED FROM MOTOR TERMINAL BLOCK STANDARD RELEASE STANDARD STOPPING (AC-SWITCHING)		POWERED FROM MOTOR TERMINAL BLOCK STANDARD RELEASE STANDARD STOPPING (AC-SWITCHING)		POWERED FROM MOTOR TERMINAL BLOCK STANDARD RELEASE FAST STOPPING (DC-SWITCHING)		POWERED FROM MOTOR TERMINAL BLOCK STANDARD RELEASE FAST STOPPING (DC-SWITCHING)			
10		10		15		15			
MOTOR	RECTIFIER	$V_{motor}$	$V_{B-AC}$	$V_{B-DC}$	MOTOR	RECTIFIER	$V_{motor}$	$V_{B-AC}$	$V_{B-DC}$
208-230n/460y 230yy/460y	GUE40V GUE40V	208 VAC 230 VAC	230 VAC 230 VAC	205 VDC 205 VDC	208-230n/460y 230yy/460y	GUE40V GUE40V	460 VAC 460 VAC	460 VAC 460 VAC	205 VDC 205 VDC
GU102A		GU102B		GU104A		GU104B			
SEPERATE POWER SOURCE STANDARD RELEASE STANDARD STOPPING (AC-SWITCHING)		SEPERATE POWER SOURCE STANDARD RELEASE STANDARD STOPPING (AC-SWITCHING)		SEPERATE POWER SOURCE STANDARD RELEASE FAST STOPPING (DC-SWITCHING)		SEPERATE POWER SOURCE STANDARD RELEASE FAST STOPPING (DC-SWITCHING)			
20		20		25		25			
MOTOR	RECTIFIER	$V_{motor}$	$V_{B-AC}$	$V_{B-DC}$	MOTOR	RECTIFIER	$V_{motor}$	$V_{B-AC}$	$V_{B-DC}$
208-230n/460y 230yy/460y	GUE40V GUE40V	208 VAC 230 VAC	230 VAC 230 VAC	205 VDC 205 VDC	208-230n/460y 230yy/460y	GUE40V GUE40V	460 VAC 460 VAC	460 VAC 460 VAC	205 VDC 205 VDC

BRAKES

\* The normally open contact/s (NO) is not supplied by NORD. It must close at the same time power is supplied to the brake. The contact must be capable of switching inductive loads and/or be rated IEC AC3.

= Braking Method



## GPE Rectifier - Connection Diagrams

Diagram ID	Power Source	Stopping Method	Voltage Level
GP101A	POWERED FROM MOTOR TERMINAL BLOCK	FAST-RELEASE (OVER EXCITATION) NORMAL STOPPING (AC-SWITCHING)	LOW VOLTAGE
GP101B	POWERED FROM MOTOR TERMINAL BLOCK	FAST-RELEASE (OVER EXCITATION) NORMAL STOPPING (AC-SWITCHING)	HIGH VOLTAGE
GP101C	POWERED FROM MOTOR TERMINAL BLOCK	FAST-RELEASE (OVER EXCITATION) NORMAL STOPPING (AC-SWITCHING)	HIGH VOLTAGE
GP101D	POWERED FROM MOTOR TERMINAL BLOCK	FAST-RELEASE (OVER EXCITATION) NORMAL STOPPING (AC-SWITCHING)	LOW VOLTAGE
GP101E	POWERED FROM MOTOR TERMINAL BLOCK	FAST-RELEASE (OVER EXCITATION) NORMAL STOPPING (AC-SWITCHING)	HIGH VOLTAGE
GP102A	POWERED FROM MOTOR TERMINAL BLOCK	FAST-RELEASE (OVER EXCITATION) FAST STOPPING (DC-SWITCHING)	LOW VOLTAGE
GP102B	POWERED FROM MOTOR TERMINAL BLOCK	FAST-RELEASE (OVER EXCITATION) FAST STOPPING (DC-SWITCHING)	HIGH VOLTAGE
GP102C	POWERED FROM MOTOR TERMINAL BLOCK	FAST-RELEASE (OVER EXCITATION) FAST STOPPING (DC-SWITCHING)	HIGH VOLTAGE
GP102D	POWERED FROM MOTOR TERMINAL BLOCK	FAST-RELEASE (OVER EXCITATION) FAST STOPPING (DC-SWITCHING)	LOW VOLTAGE
GP102E	POWERED FROM MOTOR TERMINAL BLOCK	FAST-RELEASE (OVER EXCITATION) FAST STOPPING (DC-SWITCHING)	HIGH VOLTAGE
GP103A	POWERED FROM MOTOR TERMINAL BLOCK	STANDARD RELEASE VERY FAST STOPPING (DC-SWITCHING + REDUCED POWER HOLDING)	LOW VOLTAGE
GP103B	POWERED FROM MOTOR TERMINAL BLOCK	STANDARD RELEASE VERY FAST STOPPING (DC-SWITCHING + REDUCED POWER HOLDING)	HIGH VOLTAGE



\* The normally open contact/s (NO) is not supplied by NORD. It must close at the same time power is supplied to the brake. The contact must be capable of switching inductive loads and/or be rated IEC AC3. = Braking Method



## GPU Rectifier - Connection Diagrams

Diagram ID	Power Source	Stopping Method	Braking Method	Motor Starter	Motor	Rectifier	V <sub>motor</sub>	V <sub>B-AC</sub>	V <sub>B-DC</sub>
GP103C	POWERED FROM MOTOR TERMINAL BLOCK	STANDARD RELEASE	VERY FAST STOPPING (DC-SWITCHING + REDUCED POWER HOLDING)	LOW VOLTAGE	208Δ/360y 230Δ/400y	GPE20L	208 VAC 230 VAC	208 VAC 230 VAC	180 VDC 205 VDC
GP103D	POWERED FROM MOTOR TERMINAL BLOCK	STANDARD RELEASE	VERY FAST STOPPING (DC-SWITCHING + REDUCED POWER HOLDING)	HIGH VOLTAGE	230Δ/400y	GPE20L	400 VAC	230 VAC	205 VDC
GP104A	SEPERATE POWER SOURCE	FAST-RELEASE (OVER EXCITATION)	NORMAL STOPPING (AC-SWITCHING)	LOW VOLTAGE	230y/460y	GPU20L	230 VAC	230 VAC	105 VDC
GP104B	SEPERATE POWER SOURCE	FAST-RELEASE (OVER EXCITATION)	NORMAL STOPPING (AC-SWITCHING)	HIGH VOLTAGE	230y/460y	GPU20L	460 VAC	230 VAC	105 VDC
GP104C	SEPERATE POWER SOURCE	FAST-RELEASE (OVER EXCITATION)	NORMAL STOPPING (AC-SWITCHING)	HIGH VOLTAGE	230y/460y	GPU40L	460 VAC	460 VAC	205 VDC
GP104D	SEPERATE POWER SOURCE	FAST-RELEASE (OVER EXCITATION)	NORMAL STOPPING (AC-SWITCHING)	LOW VOLTAGE	208Δ/360y 230Δ/400y 400Δ/690y 460Δ/y	GPU20L GPU20L GPU40L GPU40L	208 VAC 230 VAC 400 VAC 460 VAC	208 VAC 230 VAC 400 VAC 460 VAC	105 VDC 105 VDC 180 VDC 205 VDC
GP104E	SEPERATE POWER SOURCE	FAST-RELEASE (OVER EXCITATION)	NORMAL STOPPING (AC-SWITCHING)	HIGH VOLTAGE	230Δ/400y 332Δ/575y	GPU20L GPU40L	400 VAC 575 VAC	230 VAC 332 VAC	105 VDC 180 VDC
GP105A	SEPERATE POWER SOURCE	FAST-RELEASE (OVER EXCITATION)	FAST STOPPING (DC-SWITCHING)	LOW VOLTAGE	230y/460y	GPU20L	230 VAC	230 VAC	105 VDC
GP105B	SEPERATE POWER SOURCE	FAST-RELEASE (OVER EXCITATION)	FAST STOPPING (DC-SWITCHING)	HIGH VOLTAGE	230y/460y	GPU20L	460 VAC	230 VAC	105 VDC
GP105C	SEPERATE POWER SOURCE	FAST-RELEASE (OVER EXCITATION)	FAST STOPPING (DC-SWITCHING)	HIGH VOLTAGE	230y/460y	GPU40L	460 VAC	460 VAC	205 VDC
GP105D	SEPERATE POWER SOURCE	FAST-RELEASE (OVER EXCITATION)	FAST STOPPING (DC-SWITCHING)	LOW VOLTAGE	208Δ/360y 230Δ/400y 400Δ/690y 460Δ/y	GPU20L GPU20L GPU40L GPU40L	208 VAC 230 VAC 400 VAC 460 VAC	208 VAC 230 VAC 400 VAC 460 VAC	105 VDC 105 VDC 180 VDC 205 VDC
GP105E	SEPERATE POWER SOURCE	FAST-RELEASE (OVER EXCITATION)	FAST STOPPING (DC-SWITCHING)	HIGH VOLTAGE	230Δ/400y 332Δ/575y	GPU20L GPU40L	400 VAC 575 VAC	230 VAC 332 VAC	105 VDC 180 VDC

\* The normally open contact/s (NO) is not supplied by NORD. It must close at the same time power is supplied to the brake. The contact must be capable of switching inductive loads and/or be rated IEC AC3.







## GPE & GPU Rectifier - Connection Diagrams

GP106A		GP106B		GP106C		GP106D													
SEPERATE POWER SOURCE STANDARD RELEASE VERY FAST STOPPING (DC-SWITCHING + REDUCED POWER HOLDING)		SEPERATE POWER SOURCE STANDARD RELEASE VERY FAST STOPPING (DC-SWITCHING + REDUCED POWER HOLDING)		SEPERATE POWER SOURCE STANDARD RELEASE VERY FAST STOPPING (DC-SWITCHING + REDUCED POWER HOLDING)		SEPERATE POWER SOURCE STANDARD RELEASE VERY FAST STOPPING (DC-SWITCHING + REDUCED POWER HOLDING)													
55		55		55		55													
MOTOR	RECTIFIER	V <sub>motor</sub>	V <sub>B-AC</sub>	V <sub>B-DC</sub>	MOTOR	RECTIFIER	V <sub>motor</sub>	V <sub>B-AC</sub>	V <sub>B-DC</sub>	MOTOR	RECTIFIER	V <sub>motor</sub>	V <sub>B-AC</sub>	V <sub>B-DC</sub>	MOTOR	RECTIFIER	V <sub>motor</sub>	V <sub>B-AC</sub>	V <sub>B-DC</sub>
230Vr/460y	GPU20L	230 VAC	230 VAC	205 VDC	230Vr/460y	GPU20L	460 VAC	230 VAC	205 VDC	208Δ/360y 230Δ/400y	GPU20L GPU20L	208 VAC 230 VAC	208 VAC 230 VAC	180 VDC 205 VDC	230Δ/400y	GPU20L	400 VAC	230 VAC	205 VDC
PMG101A		PMG101B		PMG101C		PMG101D													
POWERED FROM MOTOR TERMINAL BLOCK FAST-RELEASE (OVER EXCITATION) NORMAL STOPPING (AC-SWITCHING)		POWERED FROM MOTOR TERMINAL BLOCK FAST-RELEASE (OVER EXCITATION) NORMAL STOPPING (AC-SWITCHING)		POWERED FROM MOTOR TERMINAL BLOCK FAST-RELEASE (OVER EXCITATION) NORMAL STOPPING (AC-SWITCHING)		POWERED FROM MOTOR TERMINAL BLOCK FAST-RELEASE (OVER EXCITATION) NORMAL STOPPING (AC-SWITCHING)													
30		30		30		30													
MOTOR	RECTIFIER	V <sub>motor</sub>	V <sub>B-AC</sub>	V <sub>B-DC</sub>	MOTOR	RECTIFIER	V <sub>motor</sub>	V <sub>B-AC</sub>	V <sub>B-DC</sub>	MOTOR	RECTIFIER	V <sub>motor</sub>	V <sub>B-AC</sub>	V <sub>B-DC</sub>	MOTOR	RECTIFIER	V <sub>motor</sub>	V <sub>B-AC</sub>	V <sub>B-DC</sub>
230Vr/460y	PMG500	230 VAC	230 VAC	105 VDC	230Vr/460y	PMG500	460 VAC	230 VAC	105 VDC	230Vr/460y	PMG500	460 VAC	460 VAC	205 VDC	208Δ/360y 230Δ/400y 400Δ/690y 460Δ/γ	PMG500	208 VAC 230 VAC 400 VAC 460 VAC	208 VAC 230 VAC 400 VAC 460 VAC	105 VDC 105 VDC 180 VDC 205 VDC
PMG101E		PMG102A		PMG102B		PMG102C													
POWERED FROM MOTOR TERMINAL BLOCK FAST-RELEASE (OVER EXCITATION) NORMAL STOPPING (AC-SWITCHING)		POWERED FROM MOTOR TERMINAL BLOCK FAST-RELEASE (OVER EXCITATION) FAST STOPPING (DC-SWITCHING)		POWERED FROM MOTOR TERMINAL BLOCK FAST-RELEASE (OVER EXCITATION) FAST STOPPING (DC-SWITCHING)		POWERED FROM MOTOR TERMINAL BLOCK FAST-RELEASE (OVER EXCITATION) FAST STOPPING (DC-SWITCHING)													
30		35		35		35													
MOTOR	RECTIFIER	V <sub>motor</sub>	V <sub>B-AC</sub>	V <sub>B-DC</sub>	MOTOR	RECTIFIER	V <sub>motor</sub>	V <sub>B-AC</sub>	V <sub>B-DC</sub>	MOTOR	RECTIFIER	V <sub>motor</sub>	V <sub>B-AC</sub>	V <sub>B-DC</sub>	MOTOR	RECTIFIER	V <sub>motor</sub>	V <sub>B-AC</sub>	V <sub>B-DC</sub>
230Δ/400y	PMG500	400 VAC	230 VAC	105 VDC	230Vr/460y	PMG500	230 VAC	230 VAC	105 VDC	230Vr/460y	PMG500	460 VAC	230 VAC	105 VDC	230Vr/460y	PMG500	460 VAC	460 VAC	205 VDC

\* The normally open contact/s (NO) is not supplied by NORD. It must close at the same time power is supplied to the brake. The contact must be capable of switching inductive loads and/or be rated IEC AC3.

= Braking Method



## PMG Rectifier - Connection Diagrams

Diagram ID	Power Source	Stopping Method	Braking Method	Motor Voltage	Rectifier Voltage	Motor Voltage	Rectifier Voltage	Motor Voltage	Rectifier Voltage	Motor Voltage	Rectifier Voltage
PMG102D	POWERED FROM MOTOR TERMINAL BLOCK	FAST-RELEASE (OVER EXCITATION) FAST STOPPING (DC-SWITCHING)	LOW VOLTAGE	208Δ/360V 230Δ/400V 400Δ/690V 460Δ/γ	PMG500	208 VAC 230 VAC 400 VAC 460 VAC	208 VAC 230 VAC 400 VAC 460 VAC	105 VDC 105 VDC 180 VDC 205 VDC			
PMG102E	POWERED FROM MOTOR TERMINAL BLOCK	FAST-RELEASE (OVER EXCITATION) FAST STOPPING (DC-SWITCHING)	HIGH VOLTAGE	230Δ/400V	PMG500	400 VAC	230 VAC	105 VDC			
PMG103A	POWERED FROM MOTOR TERMINAL BLOCK	STANDARD RELEASE VERY FAST STOPPING (DC-SWITCHING + REDUCED POWER HOLDING)	LOW VOLTAGE	230V/460V	PMG500	230 VAC	230 VAC	205 VDC			
PMG103B	POWERED FROM MOTOR TERMINAL BLOCK	STANDARD RELEASE VERY FAST STOPPING (DC-SWITCHING + REDUCED POWER HOLDING)	HIGH VOLTAGE	230V/460V	PMG500	460 VAC	230 VAC	205 VDC			
PMG103C	POWERED FROM MOTOR TERMINAL BLOCK	STANDARD RELEASE VERY FAST STOPPING (DC-SWITCHING + REDUCED POWER HOLDING)	LOW VOLTAGE	208Δ/360V 230Δ/400V	PMG500	208 VAC 230 VAC	180 VAC 230 VAC	105 VDC 205 VDC			
PMG103D	POWERED FROM MOTOR TERMINAL BLOCK	STANDARD RELEASE VERY FAST STOPPING (DC-SWITCHING + REDUCED POWER HOLDING)	HIGH VOLTAGE	230Δ/400V	PMG500	400 VAC	230 VAC	205 VDC			
PMG104A	SEPERATE POWER SOURCE	FAST-RELEASE (OVER EXCITATION) NORMAL STOPPING (AC-SWITCHING)	LOW VOLTAGE	230V/460V	PMG500	230 VAC	230 VAC	105 VDC			
PMG104B	SEPERATE POWER SOURCE	FAST-RELEASE (OVER EXCITATION) NORMAL STOPPING (AC-SWITCHING)	HIGH VOLTAGE	230V/460V	PMG500	460 VAC	230 VAC	105 VDC			
PMG104C	SEPERATE POWER SOURCE	FAST-RELEASE (OVER EXCITATION) NORMAL STOPPING (AC-SWITCHING)	HIGH VOLTAGE	230V/460V	PMG500	460 VAC	460 VAC	205 VDC			
PMG104D	SEPERATE POWER SOURCE	FAST-RELEASE (OVER EXCITATION) NORMAL STOPPING (AC-SWITCHING)	LOW VOLTAGE	208Δ/360V 230Δ/400V 400Δ/690V 460Δ/γ	PMG500	208 VAC 230 VAC 400 VAC 460 VAC	208 VAC 230 VAC 400 VAC 460 VAC	105 VDC 105 VDC 180 VDC 205 VDC			
PMG104E	SEPERATE POWER SOURCE	FAST-RELEASE (OVER EXCITATION) NORMAL STOPPING (AC-SWITCHING)	HIGH VOLTAGE	230Δ/400V	PMG500	400 VAC	230 VAC	105 VDC			
PMG105A	SEPERATE POWER SOURCE	FAST-RELEASE (OVER EXCITATION) FAST STOPPING (DC-SWITCHING)	LOW VOLTAGE	230V/460V	PMG500	230 VAC	230 VAC	105 VDC			

\* The normally open contact/s (NO) is not supplied by NORD. It must close at the same time power is supplied to the brake. The contact must be capable of switching inductive loads and/or be rated IEC AC3.

= Braking Method



## PMG Rectifier - Connection Diagrams

PMG105B	PMG105C	PMG105D	PMG105E																																																							
<p>SEPERATE POWER SOURCE FAST-RELEASE (OVER EXCITATION) FAST STOPPING (DC-SWITCHING)</p> <p><b>50</b></p> <p>RECTIFIER</p> <p>BRAKE COIL <math>V_{B-DC}</math></p> <p>HIGH VOLTAGE</p> <p>MOTOR STARTER <math>V_{motor}</math></p> <table border="1"> <thead> <tr> <th>MOTOR</th> <th>RECTIFIER</th> <th><math>V_{motor}</math></th> <th><math>V_{B-AC}</math></th> <th><math>V_{B-DC}</math></th> </tr> </thead> <tbody> <tr> <td>230Y/460Y</td> <td>PMG500</td> <td>460 VAC</td> <td>230 VAC</td> <td>105 VDC</td> </tr> </tbody> </table>	MOTOR	RECTIFIER	$V_{motor}$	$V_{B-AC}$	$V_{B-DC}$	230Y/460Y	PMG500	460 VAC	230 VAC	105 VDC	<p>SEPERATE POWER SOURCE FAST-RELEASE (OVER EXCITATION) FAST STOPPING (DC-SWITCHING)</p> <p><b>50</b></p> <p>RECTIFIER</p> <p>BRAKE COIL <math>V_{B-DC}</math></p> <p>HIGH VOLTAGE</p> <p>MOTOR STARTER <math>V_{motor}</math></p> <table border="1"> <thead> <tr> <th>MOTOR</th> <th>RECTIFIER</th> <th><math>V_{motor}</math></th> <th><math>V_{B-AC}</math></th> <th><math>V_{B-DC}</math></th> </tr> </thead> <tbody> <tr> <td>230Y/460Y</td> <td>PMG500</td> <td>460 VAC</td> <td>460 VAC</td> <td>205 VDC</td> </tr> </tbody> </table>	MOTOR	RECTIFIER	$V_{motor}$	$V_{B-AC}$	$V_{B-DC}$	230Y/460Y	PMG500	460 VAC	460 VAC	205 VDC	<p>SEPERATE POWER SOURCE FAST-RELEASE (OVER EXCITATION) FAST STOPPING (DC-SWITCHING)</p> <p><b>50</b></p> <p>RECTIFIER</p> <p>BRAKE COIL <math>V_{B-DC}</math></p> <p>LOW VOLTAGE</p> <p>MOTOR STARTER <math>V_{motor}</math></p> <table border="1"> <thead> <tr> <th>MOTOR</th> <th>RECTIFIER</th> <th><math>V_{motor}</math></th> <th><math>V_{B-AC}</math></th> <th><math>V_{B-DC}</math></th> </tr> </thead> <tbody> <tr> <td>208Δ/360Y</td> <td>PMG500</td> <td>208 VAC</td> <td>208 VAC</td> <td>105 VDC</td> </tr> <tr> <td>230Δ/400Y</td> <td>PMG500</td> <td>230 VAC</td> <td>230 VAC</td> <td>105 VDC</td> </tr> <tr> <td>400Δ/690Y</td> <td>PMG500</td> <td>400 VAC</td> <td>400 VAC</td> <td>180 VDC</td> </tr> <tr> <td>460Δ/Y</td> <td>PMG500</td> <td>460 VAC</td> <td>460 VAC</td> <td>205 VDC</td> </tr> </tbody> </table>	MOTOR	RECTIFIER	$V_{motor}$	$V_{B-AC}$	$V_{B-DC}$	208Δ/360Y	PMG500	208 VAC	208 VAC	105 VDC	230Δ/400Y	PMG500	230 VAC	230 VAC	105 VDC	400Δ/690Y	PMG500	400 VAC	400 VAC	180 VDC	460Δ/Y	PMG500	460 VAC	460 VAC	205 VDC	<p>SEPERATE POWER SOURCE FAST-RELEASE (OVER EXCITATION) FAST STOPPING (DC-SWITCHING)</p> <p><b>50</b></p> <p>RECTIFIER</p> <p>BRAKE COIL <math>V_{B-DC}</math></p> <p>HIGH VOLTAGE</p> <p>MOTOR STARTER <math>V_{motor}</math></p> <table border="1"> <thead> <tr> <th>MOTOR</th> <th>RECTIFIER</th> <th><math>V_{motor}</math></th> <th><math>V_{B-AC}</math></th> <th><math>V_{B-DC}</math></th> </tr> </thead> <tbody> <tr> <td>230Δ/400Y</td> <td>PMG500</td> <td>400 VAC</td> <td>230 VAC</td> <td>105 VDC</td> </tr> </tbody> </table>	MOTOR	RECTIFIER	$V_{motor}$	$V_{B-AC}$	$V_{B-DC}$	230Δ/400Y	PMG500	400 VAC	230 VAC	105 VDC
MOTOR	RECTIFIER	$V_{motor}$	$V_{B-AC}$	$V_{B-DC}$																																																						
230Y/460Y	PMG500	460 VAC	230 VAC	105 VDC																																																						
MOTOR	RECTIFIER	$V_{motor}$	$V_{B-AC}$	$V_{B-DC}$																																																						
230Y/460Y	PMG500	460 VAC	460 VAC	205 VDC																																																						
MOTOR	RECTIFIER	$V_{motor}$	$V_{B-AC}$	$V_{B-DC}$																																																						
208Δ/360Y	PMG500	208 VAC	208 VAC	105 VDC																																																						
230Δ/400Y	PMG500	230 VAC	230 VAC	105 VDC																																																						
400Δ/690Y	PMG500	400 VAC	400 VAC	180 VDC																																																						
460Δ/Y	PMG500	460 VAC	460 VAC	205 VDC																																																						
MOTOR	RECTIFIER	$V_{motor}$	$V_{B-AC}$	$V_{B-DC}$																																																						
230Δ/400Y	PMG500	400 VAC	230 VAC	105 VDC																																																						
<p>SEPERATE POWER SOURCE STANDARD RELEASE VERY FAST STOPPING (DC-SWITCHING + REDUCED POWER HOLDING)</p> <p><b>55</b></p> <p>RECTIFIER</p> <p>BRAKE COIL <math>V_{B-DC}</math></p> <p>LOW VOLTAGE</p> <p>MOTOR STARTER <math>V_{motor}</math></p> <table border="1"> <thead> <tr> <th>MOTOR</th> <th>RECTIFIER</th> <th><math>V_{motor}</math></th> <th><math>V_{B-AC}</math></th> <th><math>V_{B-DC}</math></th> </tr> </thead> <tbody> <tr> <td>230Y/460Y</td> <td>PMG500</td> <td>230 VAC</td> <td>230 VAC</td> <td>205 VDC</td> </tr> </tbody> </table>	MOTOR	RECTIFIER	$V_{motor}$	$V_{B-AC}$	$V_{B-DC}$	230Y/460Y	PMG500	230 VAC	230 VAC	205 VDC	<p>SEPERATE POWER SOURCE STANDARD RELEASE VERY FAST STOPPING (DC-SWITCHING + REDUCED POWER HOLDING)</p> <p><b>55</b></p> <p>RECTIFIER</p> <p>BRAKE COIL <math>V_{B-DC}</math></p> <p>HIGH VOLTAGE</p> <p>MOTOR STARTER <math>V_{motor}</math></p> <table border="1"> <thead> <tr> <th>MOTOR</th> <th>RECTIFIER</th> <th><math>V_{motor}</math></th> <th><math>V_{B-AC}</math></th> <th><math>V_{B-DC}</math></th> </tr> </thead> <tbody> <tr> <td>230Y/460Y</td> <td>PMG500</td> <td>460 VAC</td> <td>230 VAC</td> <td>205 VDC</td> </tr> </tbody> </table>	MOTOR	RECTIFIER	$V_{motor}$	$V_{B-AC}$	$V_{B-DC}$	230Y/460Y	PMG500	460 VAC	230 VAC	205 VDC	<p>SEPERATE POWER SOURCE STANDARD RELEASE VERY FAST STOPPING (DC-SWITCHING + REDUCED POWER HOLDING)</p> <p><b>55</b></p> <p>RECTIFIER</p> <p>BRAKE COIL <math>V_{B-DC}</math></p> <p>LOW VOLTAGE</p> <p>MOTOR STARTER <math>V_{motor}</math></p> <table border="1"> <thead> <tr> <th>MOTOR</th> <th>RECTIFIER</th> <th><math>V_{motor}</math></th> <th><math>V_{B-AC}</math></th> <th><math>V_{B-DC}</math></th> </tr> </thead> <tbody> <tr> <td>208Δ/360Y</td> <td>PMG500</td> <td>208 VAC</td> <td>208 VAC</td> <td>180 VDC</td> </tr> <tr> <td>230Δ/400Y</td> <td>PMG500</td> <td>230 VAC</td> <td>230 VAC</td> <td>205 VDC</td> </tr> </tbody> </table>	MOTOR	RECTIFIER	$V_{motor}$	$V_{B-AC}$	$V_{B-DC}$	208Δ/360Y	PMG500	208 VAC	208 VAC	180 VDC	230Δ/400Y	PMG500	230 VAC	230 VAC	205 VDC	<p>SEPERATE POWER SOURCE STANDARD RELEASE VERY FAST STOPPING (DC-SWITCHING + REDUCED POWER HOLDING)</p> <p><b>55</b></p> <p>RECTIFIER</p> <p>BRAKE COIL <math>V_{B-DC}</math></p> <p>HIGH VOLTAGE</p> <p>MOTOR STARTER <math>V_{motor}</math></p> <table border="1"> <thead> <tr> <th>MOTOR</th> <th>RECTIFIER</th> <th><math>V_{motor}</math></th> <th><math>V_{B-AC}</math></th> <th><math>V_{B-DC}</math></th> </tr> </thead> <tbody> <tr> <td>230Δ/400Y</td> <td>PMG500</td> <td>400 VAC</td> <td>230 VAC</td> <td>205 VDC</td> </tr> </tbody> </table>	MOTOR	RECTIFIER	$V_{motor}$	$V_{B-AC}$	$V_{B-DC}$	230Δ/400Y	PMG500	400 VAC	230 VAC	205 VDC										
MOTOR	RECTIFIER	$V_{motor}$	$V_{B-AC}$	$V_{B-DC}$																																																						
230Y/460Y	PMG500	230 VAC	230 VAC	205 VDC																																																						
MOTOR	RECTIFIER	$V_{motor}$	$V_{B-AC}$	$V_{B-DC}$																																																						
230Y/460Y	PMG500	460 VAC	230 VAC	205 VDC																																																						
MOTOR	RECTIFIER	$V_{motor}$	$V_{B-AC}$	$V_{B-DC}$																																																						
208Δ/360Y	PMG500	208 VAC	208 VAC	180 VDC																																																						
230Δ/400Y	PMG500	230 VAC	230 VAC	205 VDC																																																						
MOTOR	RECTIFIER	$V_{motor}$	$V_{B-AC}$	$V_{B-DC}$																																																						
230Δ/400Y	PMG500	400 VAC	230 VAC	205 VDC																																																						



\* The normally open contact/s (NO) is not supplied by NORD. It must close at the same time power is supplied to the brake. The contact must be capable of switching inductive loads and/or be rated IEC AC3.

= Braking Method



## IR Relay Typical Connection Diagrams

IR101A		IR101B		IR102A		IR102B													
POWERED FROM MOTOR TERMINAL BLOCK STANDARD-RELEASE FAST STOPPING (DC-SWITCHING)		POWERED FROM MOTOR TERMINAL BLOCK STANDARD-RELEASE FAST STOPPING (DC-SWITCHING)		POWERED FROM MOTOR TERMINAL BLOCK STANDARD-RELEASE FAST STOPPING (DC-SWITCHING)		POWERED FROM MOTOR TERMINAL BLOCK STANDARD-RELEASE FAST STOPPING (DC-SWITCHING)													
MOTOR	RECTIFIER	V <sub>motor</sub>	V <sub>B-AC</sub>	V <sub>B-DC</sub>	MOTOR	RECTIFIER	V <sub>motor</sub>	V <sub>B-AC</sub>	V <sub>B-DC</sub>	MOTOR	RECTIFIER	V <sub>motor</sub>	V <sub>B-AC</sub>	V <sub>B-DC</sub>	MOTOR	RECTIFIER	V <sub>motor</sub>	V <sub>B-AC</sub>	V <sub>B-DC</sub>
208/230V/460V 230V/460V	GVE20	208VAC 230 VAC	230 VAC	205 VDC 205 VDC	230V/460V	GVE20	460 VAC	230 VAC	205 VDC	208/230V/460V 230V/460V	GHE40	208VAC 230 VAC	230 VAC	105 VDC 105 VDC	230V/460V	GHE40	460 VAC	230 VAC	105 VDC
IR103		IR301		IR401		IR501													
POWERED FROM MOTOR TERMINAL BLOCK STANDARD-RELEASE FAST STOPPING (DC-SWITCHING)		POWERED FROM MOTOR TERMINAL BLOCK STANDARD-RELEASE FAST STOPPING (DC-SWITCHING)		POWERED FROM MOTOR TERMINAL BLOCK STANDARD-RELEASE FAST STOPPING (DC-SWITCHING)		POWERED FROM MOTOR TERMINAL BLOCK STANDARD-RELEASE FAST STOPPING (DC-SWITCHING)													
MOTOR	RECTIFIER	V <sub>motor</sub>	V <sub>B-AC</sub>	V <sub>B-DC</sub>	MOTOR	RECTIFIER	V <sub>motor</sub>	V <sub>B-AC</sub>	V <sub>B-DC</sub>	MOTOR	RECTIFIER	V <sub>motor</sub>	V <sub>B-AC</sub>	V <sub>B-DC</sub>	MOTOR	RECTIFIER	V <sub>motor</sub>	V <sub>B-AC</sub>	V <sub>B-DC</sub>
230V/460V	GHE40	460 VAC	460VAC	205 VDC	208Δ/360V 230Δ/400V	GVE20 GVE20	208 VAC 230 VAC	208 VAC 230 VAC	180 VDC 205 VDC	460Δ/800V	GHE40	460 VAC	460 VAC	205 VDC	332Δ/575V	GHE50	575 VAC	575 VAC	250 VDC
IR601		IR602		<div style="text-align: center;"> <h3>CAUTIONS</h3> <p><b>Requirements</b></p> <ul style="list-style-type: none"> <li>• Brake must be powered from the motor's terminal block (not separately powered)</li> <li>• Motor must be a single speed and should not be powered by a frequency inverter or soft starter.</li> </ul> </div>															
POWERED FROM MOTOR TERMINAL BLOCK STANDARD-RELEASE FAST STOPPING (DC-SWITCHING)		POWERED FROM MOTOR TERMINAL BLOCK STANDARD-RELEASE FAST STOPPING (DC-SWITCHING)																	
MOTOR	RECTIFIER	V <sub>motor</sub>	V <sub>B-AC</sub>	V <sub>B-DC</sub>	MOTOR	RECTIFIER	V <sub>motor</sub>	V <sub>B-AC</sub>	V <sub>B-DC</sub>										
230Δ/400V	GVE20	400 VAC	230 VAC	205 VDC	400Δ/690V	GHE40	400 VAC	400 VAC	180 VDC										



## IR Relay with GUE40V Dual Wave Rectifier

IR701A		IR701B		IR702A		IR702B													
POWERED FROM MOTOR TERMINAL BLOCK STANDARD-RELEASE FAST STOPPING (DC-SWITCHING) 15		POWERED FROM MOTOR TERMINAL BLOCK STANDARD-RELEASE FAST STOPPING (DC-SWITCHING) 15		POWERED FROM MOTOR TERMINAL BLOCK STANDARD-RELEASE FAST STOPPING (DC-SWITCHING) 15		POWERED FROM MOTOR TERMINAL BLOCK STANDARD-RELEASE FAST STOPPING (DC-SWITCHING) 15													
MOTOR	RECTIFIER	V <sub>motor</sub>	V <sub>B-AC</sub>	V <sub>B-DC</sub>	MOTOR	RECTIFIER	V <sub>motor</sub>	V <sub>B-AC</sub>	V <sub>B-DC</sub>	MOTOR	RECTIFIER	V <sub>motor</sub>	V <sub>B-AC</sub>	V <sub>B-DC</sub>	MOTOR	RECTIFIER	V <sub>motor</sub>	V <sub>B-AC</sub>	V <sub>B-DC</sub>
208-230vr/460v 230vr/460v	GUE40V GUE40V	208 VAC 230 VAC	230 VAC 230 VAC	205 VDC 205 VDC	208-230vr/460v 230vr/460v	GUE40V GUE40V	460 VAC 460 VAC	460 VAC 460 VAC	205 VDC 205 VDC	208Δ/360v 230Δ/400v	GUE40V GUE40V	208 VAC 230 VAC	208 VAC 230 VAC	180 VDC 205 VDC	230Δ/400v	GUE40V	400 VAC	400 VAC	180 VDC

## IR Relay & GPE Rectifier Connection Diagrams

IR151A		IR151B		IR152A		IR152B													
POWERED FROM MOTOR TERMINAL BLOCK FAST RELEASE (OVER EXCITATION) FAST STOPPING (DC-SWITCHING) 35		POWERED FROM MOTOR TERMINAL BLOCK STANDARD-RELEASE FAST STOPPING (DC-SWITCHING) 35		POWERED FROM MOTOR TERMINAL BLOCK STANDARD-RELEASE VERY FAST STOPPING (REDUCED POWER HOLD) 40		POWERED FROM MOTOR TERMINAL BLOCK STANDARD-RELEASE VERY FAST STOPPING (REDUCED POWER HOLD) 40													
MOTOR	RECTIFIER	V <sub>motor</sub>	V <sub>B-AC</sub>	V <sub>B-DC</sub>	MOTOR	RECTIFIER	V <sub>motor</sub>	V <sub>B-AC</sub>	V <sub>B-DC</sub>	MOTOR	RECTIFIER	V <sub>motor</sub>	V <sub>B-AC</sub>	V <sub>B-DC</sub>	MOTOR	RECTIFIER	V <sub>motor</sub>	V <sub>B-AC</sub>	V <sub>B-DC</sub>
230vr/460v	GPE20L	230 VAC	230 VAC	105 VDC	230vr/460v	GPE20L	460 VAC	230 VAC	105 VDC	230vr/460v	GPE20L	230 VAC	230 VAC	205 VDC	230vr/460v	GPE20L	460 VAC	230 VAC	205 VDC



### CAUTIONS



#### Requirements

- Brake must be powered from the motor's terminal block (not separately powered)
- Motor must be a single speed and should not be powered by a frequency inverter or soft starter.





## Inverter Driven Brakemotors

### Connection Guide for Brakes with AC-Switching

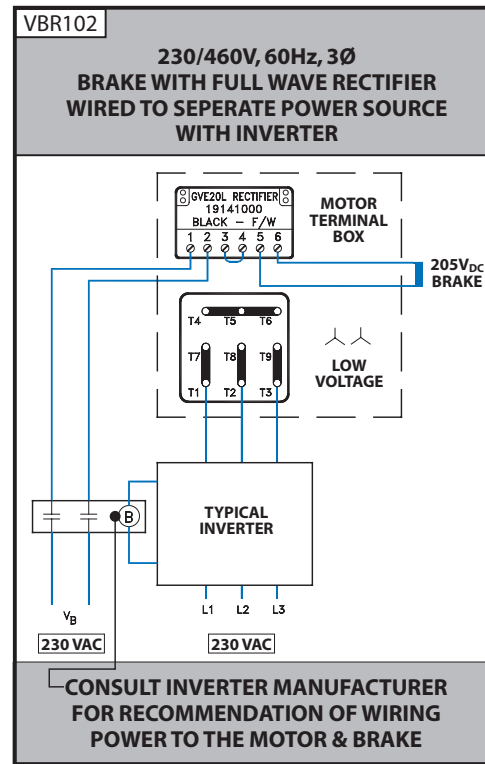
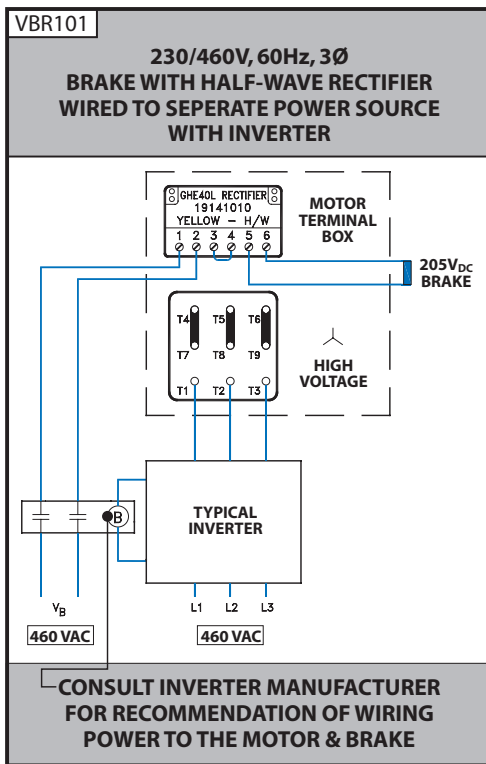

### Connection Guide for Brakes with DC-Switching

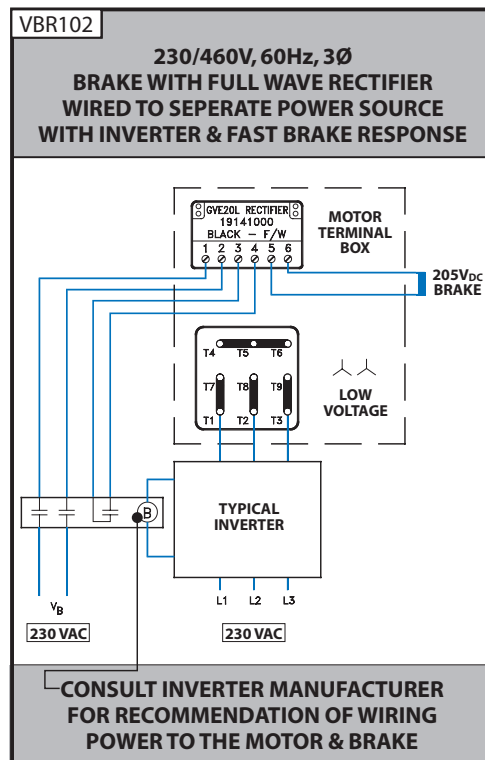
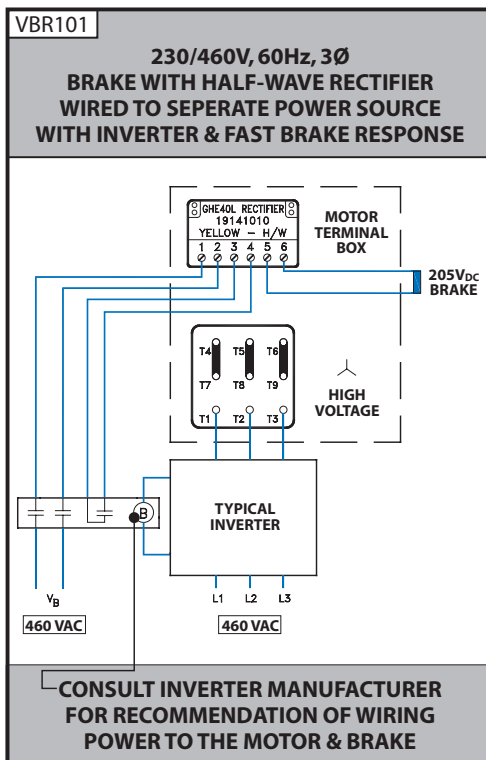

# AC Vector Drives

## AC Vector Drives

- AC Vector Drive SK 200E
- AC Vector Drive SK 500E
- Dimensions

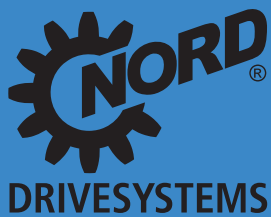
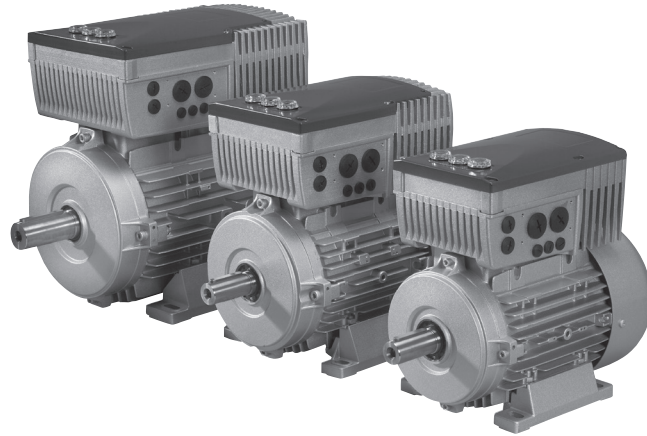

[www.nord.com](http://www.nord.com)

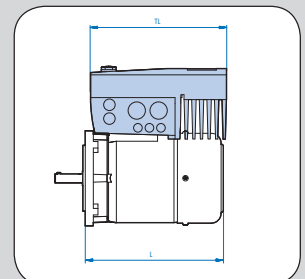
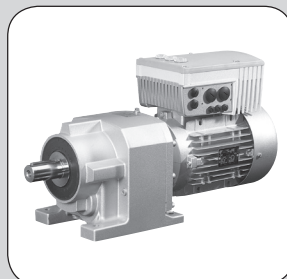

**INVERTER**  
**DUTY MOTOR**



# AC Vector Drive SK 200E Selection

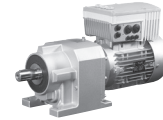

## NORDAC SK 200E Motor Mounted AC Vector Drives

NORD has now added a new member to the distributed control family, the new SK 200E AC vector drive. This series is designed to be mounted directly on the motor terminal box to create a combined, fully integrated unit for use in the field.

The functional spectrum of the SK 200E ranges from simple drive applications to complex positioning control. Their low-cost design, variable equipment, compact size and their compatibility with various connection systems, makes them especially suitable for material handling, pumping, packaging, and a variety of other industrial and commercial applications.

### Features of the SK 200E include, but not limited to:

- Sensorless & closed-loop vector control modes for superior speed regulation
- Positioning control capabilities
- Incremental encoder input as standard
- Mechanical brake rectifier and controls
- Configuration DIP switches for quick commissioning
- Plug-in storage module (EEPROM)
- "Safe Stop" and AS-Interface options
- Dynamic braking control for regenerative loads
- Various potentiometer and field bus modules for AC vector drive control
- IP55 & IP66 rated enclosures

### SK 200E AC Vector Drive Ratings

- 1~115V 0.33 - 1 hp (0.25 - 0.75kW)
- 1~240V 0.33 - 1.5 hp (0.25 - 1.1 kW)
- 3~240V 0.33 - 15 hp (0.25 - 11 kW)
- 3~480V 0.75 - 30 hp (0.55 - 22 kW)

## Electromechanical Brake Interface & Coil Voltage Selection

### 200E Selection

The SK 200E is supplied electro-mechanical brake controls with the use of a dedicated high voltage DC power supply. The SK 200E utilizes a half-wave rectifier and the brake coil voltage must be specified per the following table:

Nominal AC Input Voltage	Brake Coil Voltage
115/230 V	105 V
400 V	180 V
460/480 V	205 V

## Selection Steps

- 1. SK 2X0E or 2X5E Inverter Selection:**  
Choose the SK 200E AC Vector drive based on drive features, motor power rating, input voltage and protection class.  
SK 2X0E - Component Class Drive  
SK 2X5E - System Class Drive
- 2. SK 200E Motor Adapter Selection:**  
Select the required SK 200E motor adapter based on Frame size, Series, Input phases and protection class.
- 3. Option Module Selection (if required):**  
Choose specific option modules such as 24VDC power supply, a speed POT or L-O-R switch, or a Fieldbus /IO Extension if they are required for your AC Vector Drives needs.
- 4. Technology Unit Adapter Selection (if required):**  
Select an assembly adapter based on a specified technology unit and protection class if required.
- 5. Dynamic Braking Resistor Selection (if required):**  
Choose a specific braking resistor based on its location as well as its voltage rating and number of phases if required for your Inverter selection.
- 6. Wall Mount Adapter Selection (if required):**  
Select a wall mounting unit based on either frame size and/or technology unit if the unit is not to be mounted to a motor.
- 7. Programmer/Operator Selection (if required):**  
Choose a specific type of programming/operation device based on specified needs. (if required)

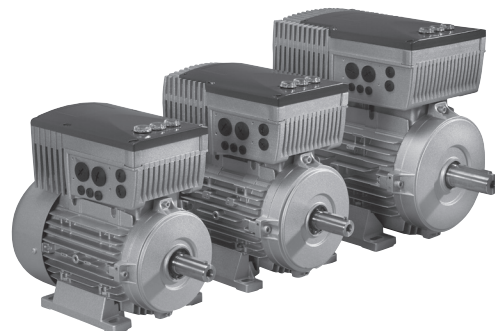

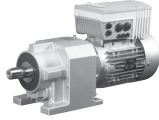

## SK200E AC Vector Drives

The range of performance allows users to select a compact device with exactly the features that are required for the particular application, thus ensuring an extremely efficient use of resources. All SK 200E versions have the same appearance, enabling uniform operation and handling. All devices and optional external technology units such as field bus or I/O systems can be linked via an integrated system bus to make integration much simpler.

		SK 200E	SK 205E	SK 210E	SK 215E	SK 220E	SK 225E	SK 230E	SK 235E
	Power range 0.33 - 30hp (0.25 kW - 22 kW) (IP55/IP66)	<input checked="" type="checkbox"/>	<input checked="" type="checkbox"/>	<input checked="" type="checkbox"/>	<input checked="" type="checkbox"/>	<input checked="" type="checkbox"/>	<input checked="" type="checkbox"/>	<input checked="" type="checkbox"/>	<input checked="" type="checkbox"/>
Design	Same Design	<input checked="" type="checkbox"/>	<input checked="" type="checkbox"/>	<input checked="" type="checkbox"/>	<input checked="" type="checkbox"/>	<input checked="" type="checkbox"/>	<input checked="" type="checkbox"/>	<input checked="" type="checkbox"/>	<input checked="" type="checkbox"/>
	Motor and Wall mounting Available	<input checked="" type="checkbox"/>	<input checked="" type="checkbox"/>	<input checked="" type="checkbox"/>	<input checked="" type="checkbox"/>	<input checked="" type="checkbox"/>	<input checked="" type="checkbox"/>	<input checked="" type="checkbox"/>	<input checked="" type="checkbox"/>
Characteristics	All standard drive functions	<input checked="" type="checkbox"/>	<input checked="" type="checkbox"/>	<input checked="" type="checkbox"/>	<input checked="" type="checkbox"/>	<input checked="" type="checkbox"/>	<input checked="" type="checkbox"/>	<input checked="" type="checkbox"/>	<input checked="" type="checkbox"/>
	Consistent parameter structure	<input checked="" type="checkbox"/>	<input checked="" type="checkbox"/>	<input checked="" type="checkbox"/>	<input checked="" type="checkbox"/>	<input checked="" type="checkbox"/>	<input checked="" type="checkbox"/>	<input checked="" type="checkbox"/>	<input checked="" type="checkbox"/>
	Multiple field bus systems available	<input checked="" type="checkbox"/>	<input checked="" type="checkbox"/>	<input checked="" type="checkbox"/>	<input checked="" type="checkbox"/>	<input checked="" type="checkbox"/>	<input checked="" type="checkbox"/>	<input checked="" type="checkbox"/>	<input checked="" type="checkbox"/>
Basic functions	Integrated 24V power supply	<input checked="" type="checkbox"/>	<input type="checkbox"/>	<input checked="" type="checkbox"/>	<input type="checkbox"/>	<input checked="" type="checkbox"/>	<input type="checkbox"/>	<input checked="" type="checkbox"/>	<input type="checkbox"/>
	24V Control voltage required		<input checked="" type="checkbox"/>		<input checked="" type="checkbox"/>		<input checked="" type="checkbox"/> *		<input checked="" type="checkbox"/> *
	Brake Management, mechanical motor brake	<input type="checkbox"/> **	<input checked="" type="checkbox"/>	<input type="checkbox"/> **	<input checked="" type="checkbox"/>	<input type="checkbox"/> **	<input checked="" type="checkbox"/>	<input type="checkbox"/> **	<input checked="" type="checkbox"/>
	Brake chopper (brake resistor optional)	<input checked="" type="checkbox"/>	<input checked="" type="checkbox"/>	<input checked="" type="checkbox"/>	<input checked="" type="checkbox"/>	<input checked="" type="checkbox"/>	<input checked="" type="checkbox"/>	<input checked="" type="checkbox"/>	<input checked="" type="checkbox"/>
	DC Braking	<input checked="" type="checkbox"/>	<input checked="" type="checkbox"/>	<input checked="" type="checkbox"/>	<input checked="" type="checkbox"/>	<input checked="" type="checkbox"/>	<input checked="" type="checkbox"/>	<input checked="" type="checkbox"/>	<input checked="" type="checkbox"/>
	Flying Start (catching a spinning motor)	<input checked="" type="checkbox"/>	<input checked="" type="checkbox"/>	<input checked="" type="checkbox"/>	<input checked="" type="checkbox"/>	<input checked="" type="checkbox"/>	<input checked="" type="checkbox"/>	<input checked="" type="checkbox"/>	<input checked="" type="checkbox"/>
	Sensorless current vector control (ISD control)	<input checked="" type="checkbox"/>	<input checked="" type="checkbox"/>	<input checked="" type="checkbox"/>	<input checked="" type="checkbox"/>	<input checked="" type="checkbox"/>	<input checked="" type="checkbox"/>	<input checked="" type="checkbox"/>	<input checked="" type="checkbox"/>
	Plug-in storage module (EEPROM)	<input checked="" type="checkbox"/>	<input checked="" type="checkbox"/>	<input checked="" type="checkbox"/>	<input checked="" type="checkbox"/>	<input checked="" type="checkbox"/>	<input checked="" type="checkbox"/>	<input checked="" type="checkbox"/>	<input checked="" type="checkbox"/>
	Line filter Class C2	<input checked="" type="checkbox"/>	<input checked="" type="checkbox"/>	<input checked="" type="checkbox"/>	<input checked="" type="checkbox"/>	<input checked="" type="checkbox"/>	<input checked="" type="checkbox"/>	<input checked="" type="checkbox"/>	<input checked="" type="checkbox"/>
	Switchable parameter sets	<input checked="" type="checkbox"/>	<input checked="" type="checkbox"/>	<input checked="" type="checkbox"/>	<input checked="" type="checkbox"/>	<input checked="" type="checkbox"/>	<input checked="" type="checkbox"/>	<input checked="" type="checkbox"/>	<input checked="" type="checkbox"/>
	Process controller / PID controller	<input checked="" type="checkbox"/>	<input type="checkbox"/>	<input checked="" type="checkbox"/>	<input type="checkbox"/>	<input checked="" type="checkbox"/>	<input type="checkbox"/>	<input checked="" type="checkbox"/>	<input type="checkbox"/>
	Incremental encoder evaluation ❶	<input checked="" type="checkbox"/>	<input checked="" type="checkbox"/>	<input checked="" type="checkbox"/>	<input checked="" type="checkbox"/>	<input checked="" type="checkbox"/>	<input checked="" type="checkbox"/>	<input checked="" type="checkbox"/>	<input checked="" type="checkbox"/>
	POSICON (positioning control) ❷	<input checked="" type="checkbox"/>	<input checked="" type="checkbox"/>	<input checked="" type="checkbox"/>	<input checked="" type="checkbox"/>	<input checked="" type="checkbox"/>	<input checked="" type="checkbox"/>	<input checked="" type="checkbox"/>	<input checked="" type="checkbox"/>
Automatic flux adaptation (energy saving function)	<input checked="" type="checkbox"/>	<input checked="" type="checkbox"/>	<input checked="" type="checkbox"/>	<input checked="" type="checkbox"/>	<input checked="" type="checkbox"/>	<input checked="" type="checkbox"/>	<input checked="" type="checkbox"/>	<input checked="" type="checkbox"/>	
Special functions	"Safe stop" function			<input checked="" type="checkbox"/>	<input checked="" type="checkbox"/>			<input checked="" type="checkbox"/>	<input checked="" type="checkbox"/>
	AS interface on board					<input checked="" type="checkbox"/>	<input checked="" type="checkbox"/>	<input checked="" type="checkbox"/>	<input checked="" type="checkbox"/>
Options	Bus modules with/without M12 plug connectors for I/Os	<input type="checkbox"/>	<input type="checkbox"/>	<input type="checkbox"/>	<input type="checkbox"/>	<input type="checkbox"/>	<input type="checkbox"/>	<input type="checkbox"/>	<input type="checkbox"/>
	I/O Modules	<input type="checkbox"/>	<input type="checkbox"/>	<input type="checkbox"/>	<input type="checkbox"/>	<input type="checkbox"/>	<input type="checkbox"/>	<input type="checkbox"/>	<input type="checkbox"/>
	Stand-alone operation (24V control power supply)	<input checked="" type="checkbox"/>	<input type="checkbox"/>	<input checked="" type="checkbox"/>	<input type="checkbox"/>	<input checked="" type="checkbox"/>	<input type="checkbox"/> *	<input checked="" type="checkbox"/>	<input type="checkbox"/> *
	Power connectors (e.g. Harting HAN 10E)	<input type="checkbox"/>	<input type="checkbox"/>	<input type="checkbox"/>	<input type="checkbox"/>	<input type="checkbox"/>	<input type="checkbox"/>	<input type="checkbox"/>	<input type="checkbox"/>
	Internal/external brake resistors	<input type="checkbox"/>	<input type="checkbox"/>	<input type="checkbox"/>	<input type="checkbox"/>	<input type="checkbox"/>	<input type="checkbox"/>	<input type="checkbox"/>	<input type="checkbox"/>
	Potentiometer versions	<input type="checkbox"/>	<input type="checkbox"/>	<input type="checkbox"/>	<input type="checkbox"/>	<input type="checkbox"/>	<input type="checkbox"/>	<input type="checkbox"/>	<input type="checkbox"/>

- Standard Functions   
  Optional Functions   
 \* 24V Supply via AS-i   
 \*\* Size 4 Includes brake management  
 ❶ Requires HTL output encoder on motor for closed loop vector.  
 ❷ With HTL output incremental encoder or CAN output absolute encoder.

# AC Vector Drive SK 200E

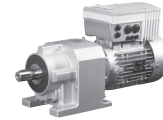

## Step 1: SK 2XXE Selection

Component Class    kW Rating    Input Voltage    Protection Class

**SK** ①  **E** ②  - ③  ④

System Class    kW Rating    Input Voltage    Protection Class

**SK** ①  **E** ②  - ③  ④

①	Component Class Series
	200 - Basic Unit
	210 - Basic Unit + Safe Stop Function
	220 - Basic Unit + AS Interface
	230 - Basic Unit + AS Interface + Safe Stop

①	System Class Series
	205 - Basic Unit
	215 - Basic Unit + Safe Stop Function
	225 - Basic Unit + AS Interface
	235 - Basic Unit + AS Interface + Safe Stop

②	Power Rating
	250 - 0.25 kW (0.33 hp)
	370 - 0.37 kW (0.50 hp)
	550 - 0.55 kW (0.75 hp)
	750 - 0.75 kW (1.00 hp)
	111 - 1.1 kW (1.50 hp)
	151 - 1.5 kW (2.00 hp)
	221 - 2.2 kW (3.00 hp)
	301 - 3.0 kW (4.00 hp)
	401 - 4.0 kW (5.00 hp)
	551 - 5.5 kW (7.50 hp)
	751 - 7.5 kW (10.0 hp)

②	Power Rating
	250 - 0.25 kW (0.33 hp)
	370 - 0.37 kW (0.50 hp)
	550 - 0.55 kW (0.75 hp)
	750 - 0.75 kW (1.00 hp)
	111 - 1.1 kW (1.50 hp)
	151 - 1.5 kW (2.00 hp)
	221 - 2.2 kW (3.00 hp)
	301 - 3.0 kW (4.00 hp)
	401 - 4.0 kW (5.00 hp)
	551 - 5.5 kW (7.50 hp)
	751 - 7.5 kW (10.0 hp)

③	Input Voltage
	112-O - 100-120V, 1-phase (0.25-0.75 kW) (0.33-1 hp)
	123-A - 200-240V, 1-phase (0.25-1.1 kW) (0.33-1.5 hp)
	323-A - 200-240V, 3-phase (0.25-4.0 kW) (0.33 - 5 hp)
	323-A - 200-240V, 3-phase (0.5-11 kW) (7.5 - 15 hp) * Size 4 only
	340-A - 380-480V, 3-phase (0.75-7.5 kW) (1-10 hp)
	340-A - 380-480V, 3-phase (11-22 kW) (15-30 hp) * Size 4 only

③	Input Voltage
	112-O - 100-120V, 1-phase (0.25-0.75 kW) (0.33-1 hp)
	123-A - 200-240V, 1-phase (0.25-0.55 kW) (0.33-0.75 hp)
	323-A - 200-240V, 3-phase (0.25-4.0 kW) (0.33 - 5 hp)
	340-A - 380-480V, 3-phase (0.75-7.5 kW) (1-10 hp)

④	Protection Class
	Blank - IP55
	-C - IP66

④	Protection Class
	Blank - IP55
	-C - IP66

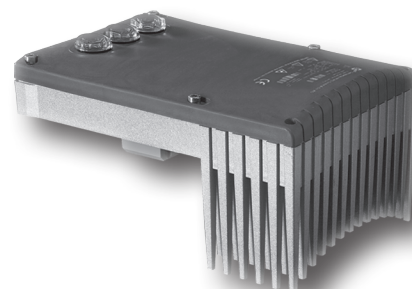

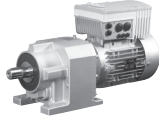

## Step 2: SK 200E Motor Adapter Selection

	Frame Size	Series	# of Input Phases	Protection Class
<b>SK T14</b>	⑤	<b>E</b> ①	- ③	④

⑤	Frame Size
• 1	<ul style="list-style-type: none"> <li>- 100-120V, 1-phase (0.25-0.37 kW) (0.33-0.50 hp)</li> <li>- 200-240V, 1-phase (0.25-0.55 kW) (0.33-0.75 hp)</li> <li>- 200-240V, 3-phase (0.25-1.1 kW) (0.33-1.5 hp)</li> <li>- 380-480V, 3-phase (0.75-2.2 kW) (0.33-3 hp)</li> </ul>
• 2	<ul style="list-style-type: none"> <li>- 100-120V, 1-phase (0.55-0.75 kW) (0.75-1.0 hp)</li> <li>- 200-240V, 1-phase (0.75-1.1 kW) (1-1.5 hp)</li> <li>- 200-240V, 3-phase (1.5-2.2 kW) (2-3 hp)</li> <li>- 380-480V, 3-phase (3.0-4.0 kW) (4-5 hp)</li> </ul>
• 3	<ul style="list-style-type: none"> <li>- 200-240V, 3-phase (3.0-4.0 kW) (4-5 hp)</li> <li>- 380-480V, 3-phase (5.0-7.5 kW) 6.5-10 hp)</li> </ul>
• 4	<ul style="list-style-type: none"> <li>- 200-240V, 3-phase (5.5-11.0 kW) (7.5-15 hp)</li> <li>- 380-480V, 3-phase (11.0-22.0 kW) (15-30 hp)</li> </ul>

①	Series
	200 - Basic Unit (Component Class)
	205 - Basic Unit (System Class)
	210 - Basic Unit + Safe Stop Function (Component Class)
	215 - Basic Unit + Safe Stop Function (System Class)
	220 - Basic Unit + AS Interface (Component Class)
	225 - Basic Unit + AS Interface (System Class)
	230 - Basic Unit + AS Interface + Safe Stop (Component Class)
	235 - Basic Unit + AS Interface + Safe Stop (System Class)

③	# of Input Phases
	3 - 3-phase

④	Protection Class
	Blank - IP55
	- C - IP66

## Motor Adapter Interface

The SK 200E requires a motor adapter/interface so it may be properly mounted to the motor or to an appropriate wall-mount bracket. The motor adapter houses the input power and motor terminals, as well as the standard control I/O. The motor adapter also allows the user to install internal option modules and dynamic braking resistors. The outside of the motor adapter has provisions to install external option modules and dynamic braking resistors, as well as quick-disconnect power and control connectors.

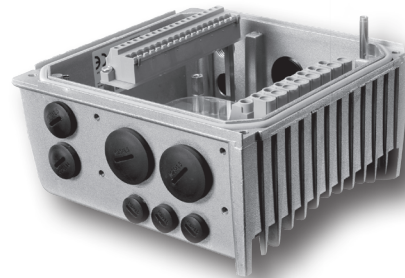

# AC Vector Drive SK 200E

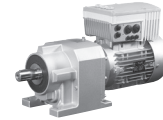

### Step 3: 24VDC Power Supply Selection (if required)

Module Type	Module Input Voltage*	Protection Class*
SK <input type="text" value="7"/> - 24V -	<input type="text" value="8"/>	<input type="text" value="4"/>

\* applies only to external "TU4" units

7 Module Type (Internal/External)
CU4 - Internal Customer Unit
TU4 - External Technology Unit
8 Module Input Voltage
123B - All 100-120V & 200-240V Units
140B - All 380-480V Units
4 Protection Class
Blank - IP55
-C - IP66

### Step 3: Speed POT & L-O-R Switch (if required)

Module Type	Module Input Voltage*	Protection Class*
SK <input type="text" value="7"/> - POT -	<input type="text" value="8"/>	<input type="text" value="4"/>

\* applies only to external "TU4" units

7 Module Type (Internal/External)
CU4 - Internal Customer Unit
TU4 - External Technology Unit
8 Module Input Voltage
123B - All 100-120V & 200-240V Units
140B - All 380-480V Units
4 Protection Class
Blank - IP55
-C - IP66

### Step 3: Fieldbus / IO Extension Selection (if required)

Module Type	Fieldbus/IOE Option	M12 Connect Option*	Protection Class*
SK <input type="text" value="7"/> -	<input type="text" value="9"/>	<input type="text" value="10"/>	<input type="text" value="4"/>

\* applies only to external "TU4" units

7 Module Type (Internal/External)
CU4 - Internal Customer Unit
TU4 - External Technology Unit
9 Fieldbus, I/O Extension Module
PBR - Profibus
CAO - CANopen
DEV - DeviceNet
IOE - I/O Extension
10 M12 Connectors for Module I/O
Blank - Not required
M12 - M12 Connectors Included
4 Protection Class
Blank - IP55
-C - IP66

### Customer Units

Internal customer interfaces enable the expansion of the range of functions of SK 200E AC vector drive without changing the physical size. Users have access to communication modules, an internal control power module or an I/O expansion.

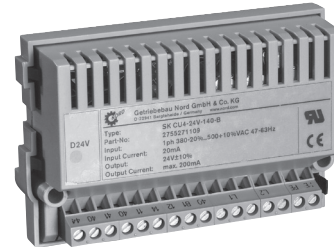

### Technology Units

For the distributed control SK 200E AC vector drives, optional technology units are available.

These units may be mounted directly on the device or separately on the machine frame or plant component. Communication systems both with & without connection facilities for sensors, actuators and control modules are available for most current applications. All external technology adapters require an adapter for proper operation and coordination with the SK 200E. (SK TI4-TU-XXX selection on page 245)

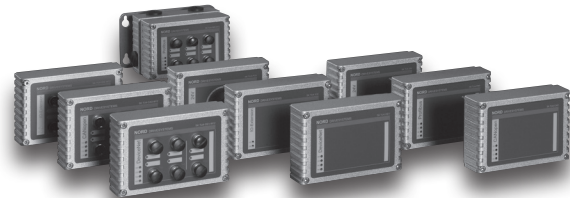

### Customer & Technology Unit Options Include:

- 24Vdc power supply
- Potentiometer & start/stop selector switch
- Expanded I/O control
- Profibus
- CANopen
- DeviceNet





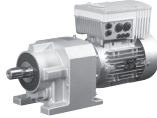

## Step 4: Technology Unit Adaptor Selection

(required for all "SK TU44-xxx" modules)

<b>SK TI4-TU-</b>	Assembly Adaptor for TU4*	Protection Class*
	①	④

\* applies only to external "TU4" units

<b>①</b>	<b>Assembly Adaptor for TU4 Technology Units</b>
BUS - For all PBR, CAO, DEV, and IOE Technology Units	
NET - For all 24V and POT Technology Units	

<b>④</b>	<b>Protection Class</b>
Blank - IP55	
-C - IP66	

## Step 5: Dynamic Braking Resistor Selection (if required)

<b>SK TI4-TU-</b>	Dynamic Braking Resistor Location	Dynamic Braking Resistor Rating
	⑫	⑬

<b>⑫</b>	<b>Dynamic Braking Resistor Location</b>
BUS - For all PBR, CAO, DEV, and IOE Technology Units	
NET - For all 24V and POT Technology Units	

<b>⑬</b>	<b>Dynamic Braking Resistor Rating</b>
1-100-100 - 100-120V, 1-phase & 200-240V 1-phase (all ratings)	
1-200-100 - 200-240V, 3-phase (0.25-2.2 kW)	
2-100-200 - 200-240V, 3-phase (3.0-4.0 kW)	
1-400-100 - 380-480V, 3-phase (0.55-4.0 kW)	
2-200-200 - 380-480V, 3-phase (5.5-7.5 kW)	

## Step 6: Wall Mount Adaptor Selection (if required)

<b>SK TIE4-WMK-</b>	Selection Code For Adaptor
	⑭

<b>⑭</b>	<b>Selection Code for Adaptor</b>
1 - For inverter frame sizes 1 & 2**	
2 - For inverter frame size 3**	
TU - For external Technology Units	

\*\* See Box 5 on page 243 for frame sizes

## Step 7: Programmer/Operation Device (if required)

<b>Programmer/Operation Device Selection</b>	
<input type="checkbox"/>	SK CSX-3H - Simple Box (LED Display)
<input type="checkbox"/>	SK PAR-3H - Parameter Box (LCD English Display)
<input type="checkbox"/>	SK PAR-2E - Panel Mount Parameter Box (LCD English Display)
<input type="checkbox"/>	RJ12-SUB/D - PC Cable for NORDCON software

## Dynamic Braking Resistor

The SK 200E also has options for internal and external dynamic braking resistors (DBR). A DBR is used for applications with regenerative loads such as lifting, cyclical, and high inertia loads. The DBR will dissipate the regenerative energy from the motor as heat using the internal brake chopper that is provided with the SK 200E.

## Wall Mount Kit

The SK 200E may be installed away from the motor with the use of a wall-mount kit. The motor adapter is mounted on the wall-mount kit instead of on the motor conduit box and may be installed on a wall, piece of machinery, or in a panel. The IP55 or IP66 protection is maintained when used with a wall-mount kit.

## Programming Tools

A variety of programming and operation interfaces are available for the SK 200E. The SK PAR-3H (hand-held) and SK PAR-2E (panel mount) provide programming, troubleshooting, and operation controls with an easy to use LCD English display. These modules have the capability of storing up to 5 different parameter sets for simple transfer of settings to other units.

The SK CSX-3H is used in a similar fashion as the SK PAR-3H and SK PAR-2E, but implements a bright, 4-digit 7-segment LED display.

With the use of Nord's RJ12-SUB/D cable, users may connect a SK 200E to a PC and configure it with NORDCON software. NORDCON is a Windows-based program that enables the user to program, upload/download parameter sets, troubleshoot with built-in oscilloscope function, and control their AC vector drive.



# AC Vector Drive SK 200E General Specifications

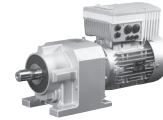

## SK 200E General Specifications

	Inverter type SK 2xxE...	Input voltage	Output voltage	Nominal motor power	Nominal motor power	Nominal output current	Typical input current
				230V [kW]	230V [hp]	rms [A]	rms [A]
<b>1 ~ 100 ... 120V</b>	-250-112-O	1 ~ 100...120V -/+10% 47...63Hz	3 AC 0-200...240V	0.25	$\frac{1}{3}$	1.7	8.9
	-370-112-O			0.37	$\frac{1}{2}$	2.2	11
	-550-112-O			0.55	$\frac{3}{4}$	3.0	13.1
	-750-112-O			0.75	1	4.0	20

	Inverter type SK 2xxE...	Input voltage	Output voltage	Nominal motor power	Nominal motor power	Nominal output current	Typical input current
				230 V [kW]	230 V [hp]	rms [A]	rms [A]
<b>1 ~ 200 ... 240V</b>	-250-123-A	1 ~ 200...240V -/+10% 47...63Hz	3 AC 0-200...240V	0.25	$\frac{1}{3}$	1.7	3.9
	-370-123-A			0.37	$\frac{1}{2}$	2.2	5.8
	-550-123-A			0.55	$\frac{3}{4}$	3.0	7.3
	-750-123-A			0.75	1	4.0	10.2
	-111-123-A			1.1	$1\frac{1}{2}$	5.5	14.7

AC VECTOR DRIVES



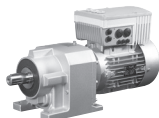

## SK 200E General Specifications

	Inverter type SK 2xxE...	Input voltage	Nominal motor power		Nominal output current rms [A]	Typical input current rms [A]
			230V [kW]	230V [hp]		
<b>3 ~ 200 ... 240V</b>	-250-323-A	3 ~ 200...240V -/+10% 47...63Hz	0.25	$\frac{1}{3}$	1.7	1.4
	-370-323-A		0.37	$\frac{1}{2}$	2.2	1.9
	-550-323-A		0.55	$\frac{3}{4}$	3.0	2.6
	-750-323-A		0.75	1	4.0	3.5
	-111-323-A		1.1	$1\frac{1}{2}$	5.5	5.1
	-151-323-A		1.5	2	7.0	6.6
	-221-323-A		2.2	3	9.5	9.1
	-301-323-A		3	4	12.5	11.8
	-401-323-A		4	5	16	15.1

	Inverter type SK 2xxE...	Input voltage	Nominal motor power		Nominal output current rms [A]	Typical input current rms [A]
			400V [kW]	460V [hp]		
<b>3 ~ 380 ... 500V</b>	-550-340-A	3 ~ 380...500V -20%/+10% 47...63Hz	0.55	$\frac{3}{4}$	1.7	1.6
	-750-340-A		0.75	1	2.3	2.2
	-111-340-A		1.1	$1\frac{1}{2}$	3.1	2.9
	-151-340-A		1.5	2	4.0	3.7
	-221-340-A		2.2	3	5.5	5.7
	-301-340-A		3.0	4	7.5	7.0
	-401-340-A		4.0	5	9.5	8.3
	-551-340-A		5.5	$7\frac{1}{2}$	12.5	11.7
	-751-340-A		7.5	10	16	15.0



# SK 200E AC Vector Drive Dimensions

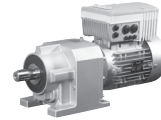

## Motor Dimensions with SK 200E Motor Mounted AC Vector Drive

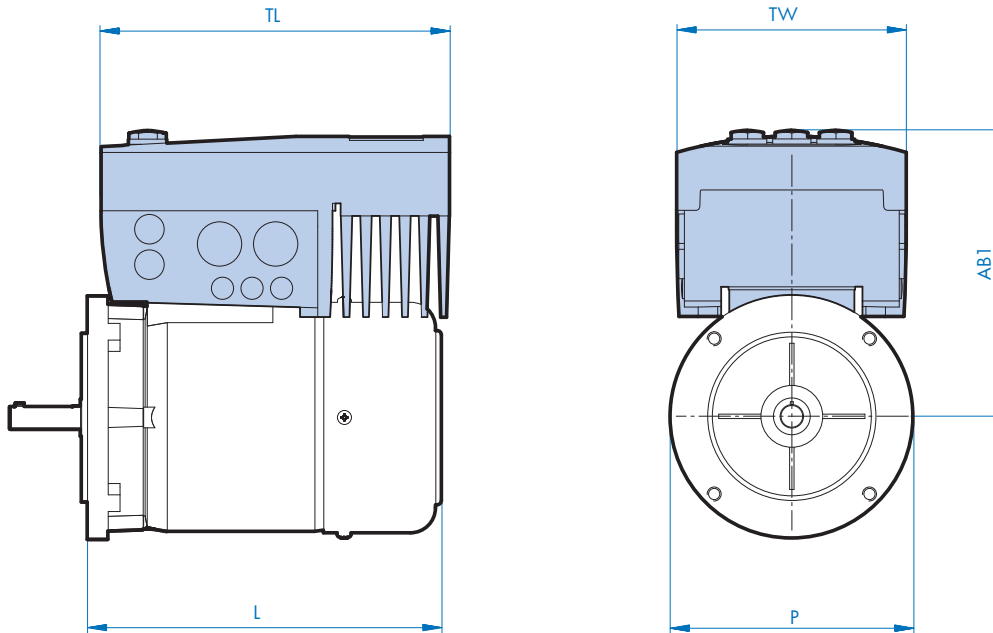

AC Vector Drive Size	Motor	Width		Length		AB1 [in]	Weight [lbs]
		P [in]	TW [in]	L [in]	TL [in]		
Size 1	71S/L	5.71	6.14	8.43	9.29	7.91	6.61
	80S/L	6.50		9.29		7.68	
	90S/L	7.20		10.87		7.87	
	100L/LA	7.91		12.05		8.23	
Size 2	80S/L	6.50	6.93	9.29	10.47	7.95	9.04
	90S/L	7.20		10.87		8.15	
	100L/LA	7.91		12.05		8.58	
	112M	8.98		12.83		8.98	
Size 3	100L/LA	7.91	8.58	12.05	12.99	9.88	15.21
	112M	8.98		12.83		10.28	
	132S/M	10.47		16.18		10.31	



## SK 200E General Specifications

Function	Specification
<b>Power / Voltage</b>	<ul style="list-style-type: none"> <li>• 1~100...120V -/+10%                      0.33 - 1 hp                      (0.25-0.75 kW)</li> <li>• 1~100...240V -/+10%                      0.33 - 1 hp                      (0.25 - 0.75 kW)</li> <li>• 1~200...240V -/+10%                      0.33 - 1.5 hp                      (0.25 - 1.1 kW)</li> <li>• 3~200...240V -/+10%                      0.33 - 15 hp                      (0.25 - 11 kW)</li> <li>• 3~380...500V -20% +10%                      0.75 - 30 hp                      (0.55 - 22 kW)</li> </ul>
<b>Input frequency rating tolerance</b>	47 ... 63 Hz
<b>Output frequency</b>	0.0 ... 400.0 Hz
<b>Pulse frequency</b>	3.0 ...16.0kHz, standard setting = 6kHz Power reduction > 8kHz for 115/230V device, > 6kHz for 400V device
<b>Rated overload capacity</b>	150% for 60s, 200% for 3.5s
<b>Protective measures against</b>	<ul style="list-style-type: none"> <li style="width: 50%;">• Overheating of the frequency inverter</li> <li style="width: 50%;">• Short circuit, earthing fault</li> <li style="width: 50%;">• Over/under-voltage</li> <li style="width: 50%;">• Over/underload, idling</li> </ul>
<b>Motor Turndown</b>	<ul style="list-style-type: none"> <li style="width: 50%;">• V/f Const Torque 10:1</li> <li style="width: 50%;">• Closed Loop Vector 1000:1</li> <li style="width: 50%;">• Sensorless Vector 30:1</li> </ul>
<b>Motor temperature Monitoring</b>	Temperature sensor (PTC), temperature monitor (bimetal), I <sup>2</sup> t- motor
<b>Digital input</b>	4x, low 0-5V, high 14-30, R <sub>i</sub> = 9.5kΩ, C <sub>i</sub> = 10nF, cycle time =4mc
<b>Electrical isolation</b>	Control terminals
<b>Control Methods</b>	<ul style="list-style-type: none"> <li style="width: 50%;">• V/f Constant torque</li> <li style="width: 50%;">• Sensorless Vector (ISD)</li> <li style="width: 50%;">• Energy saving mode</li> <li style="width: 50%;">• Closed-Loop Vector</li> </ul>
<b>Control outputs</b>	Digital output: 18-30V DC (according to VI 24V), maximum 200mA, maximum 100kΩ load Brake rectifier: maximum 0.5A choke voltage, voltage according to mains
<b>Interfaces</b>	Standard: RS 485 (USS), RS 232 (single slave), System Bus Optional: Profibus, CANopen, DeviceNet, AS Interface
<b>Energy Efficiency of AC drive</b>	Approximately 95% according to size
<b>Ambient temperature</b>	-25 ...+40°C (S1- 100% ED), -25 ... +50°C(S3 - 75% ED 15min)
<b>Storage &amp; transport temp.</b>	-25 ...+60 / 70°C
<b>Long term storage</b>	<ul style="list-style-type: none"> <li>• Connect the FI &amp; the 24V modules to the mains voltage for 60 min. before 1 storage year</li> <li>• Connect the FI &amp; the 24V modules to the 24V control for 60 min. before 1 storage year</li> <li>• Maintain this cycle throughout the storage period</li> </ul>
<b>Protection class</b>	IP55, optional IP66
<b>Maximum mounting altitude above sea level</b>	<ul style="list-style-type: none"> <li>• Up to 1000m – No power reduction</li> <li>• 1000 - 4000m – 1% per 100m power reduction (up to 2000m overvoltage cat.3)</li> <li>• 2000 - 4000m – Overvoltage cat. 2 is maintained, external overvoltage protection at the mains input is necessary</li> </ul>
<b>Waiting period between power-up cycles</b>	60 seconds for all devices in a normal operating cycle
<b>Accel / Decel Time</b>	0.0 ... 320.0s
<b>Connection terminals</b>	<ul style="list-style-type: none"> <li>• Mains or motor / brake resistance - 4mm<sup>2</sup> with wiring sleeves, 6mm<sup>2</sup> with rigid cable</li> <li>• Control unit / system bus - 2.5mm<sup>2</sup> with 1.5mm<sup>2</sup> wiring sleeves</li> <li>• RS485 / RS232 - 1xRJ12 (6-pin)</li> </ul>
<b>Connection terminal screw tightening torque</b>	1.2 - 10.5 Nm
<b>External 24V supply voltage</b>	18...30V DC, at least 200-800mA according to load



# AC Vector Drives SK 500E



## NORDAC SK 500E AC Vector Drives

NORD has now expanded its centralized control family by adding increased functionality with new versions of the SK 500E AC vector drive line. This series is designed to be mounted in a control panel to seamlessly integrate with the centralized controls.

With the SK 500E series of AC vector drives, NORD offers intelligent and cost-effective drive solutions with scalable equipment options, which are all fully compatible with regard to motor performance range, supply voltage and sizes. The basis for all models is a well-equipped basic unit with expansion possibilities through optional modules. SK 500E AC vector drives are suitable for all application areas and can be easily adapted to specific requirements with plug-in technology units.

### Features of the SK 500E include, but not limited to:

- Sensorless & closed loop vector control modes for superior speed regulation
- Positioning control capabilities
- Incremental and absolute encoder inputs
- "Safe Stop" as per EN 954-1, max. Cat. 4
- Dynamic braking control for regenerative loads
- Various potentiometer and field bus modules for AC vector drive control

### SK 500E AC Vector Drive Ratings

- 1~115V 0.33 - 1 hp (0.25 - 0.75kW)
- 1~240V 0.33 - 3 hp (0.25 - 2.2 kW)
- 3~240V 0.33 - 25 hp (0.25 - 18.5 kW)
- 3~480V 0.75 - 125 hp (0.55 - 90 kW)



## Selection Steps

### 1. SK 500E Inverter Selection:

Choose the SK 500E AC vector drive based on motor power rating, input voltage supply, and drive features. Use the SK 500E Rating & Voltage Matrix to ensure the desired Series is available in the selected kW Rating and Input Voltage ratings.

### 2. Interface Module (Tech. Unit) Selection (if required):

Choose specific technology unit such as speed POT with start/stop, fieldbus interface, or programming and display module.

### 3. Dynamic Braking Resistor Selection (if required):

Choose a specific braking resistor based on the AC vector drive's voltage and power rating

### 4. Programmer/Operator Selection (recommended):

Choose a specific type of programming/operation device based on specified needs. (if required)



## NORDAC SK 500E AC Vector Drives

The range of options and performance allows users to select a device with the exact features that are required for the application, thus ensuring an extremely efficient use of resources. All SK 500E versions have the same appearance, enabling uniform operation and handling. All devices and optional technology units such as field bus or I/O systems can be linked via an integrated system bus to make integration much simpler.

		SK 500E	SK 505E	SK 510E	SK 511E	SK 515E	SK 520E	SK 530E	SK 535E	SK 540E	SK 545E
Power	Power range 0.33 kW - 10 kW	☑	☑	☑	☑		☑	☑	☑	☑	☑
	Power range 15kW - 125kW					☑			☑		☑
Basic functions	Same design	☑	☑	☑	☑	☑	☑	☑	☑	☑	☑
	Coldplate up to Size 4, external heat sink technology up to Size 2	☑	☑	☑	☑		☑	☑	☑	☑	☑
Basic functions	Sensorless current vector control (ISD control)	☑	☑	☑	☑	☑	☑	☑	☑	☑	☑
	Line filter Class C2	☑	☑	☑	☑	☑	☑	☑	☑	☑	☑
	Brake management, mech. motor brake	☑	☑	☑	☑	☑	☑	☑	☑	☑	☑
	Brake chopper (brake resistor optional)	☑	☑	☑	☑	☑	☑	☑	☑	☑	☑
	Switchable parameter sets	☑	☑	☑	☑	☑	☑	☑	☑	☑	☑
	All normal drive functions	☑	☑	☑	☑	☑	☑	☑	☑	☑	☑
	Process controller / PID controller	☑	☑	☑	☑	☑	☑	☑	☑	☑	☑
	Consistent parameter structure	☑	☑	☑	☑	☑	☑	☑	☑	☑	☑
	All common bus systems via Tech. Units	☑	☑	☑	☑	☑	☑	☑	☑	☑	☑
	Automatic flux optimisation (energy saving function)	☑	☑	☑	☑	☑	☑	☑	☑	☑	☑
Special options	"Safe stop" function			☑	☑	☑		☑	☑	☑	☑
	CANopen on Board				☑	☑ (Size 5-7)	☑	☑	☑	☑	☑
	Incremental encoder input						☑	☑	☑	☑	☑
	Additional control inputs and outputs						☑	☑	☑	☑	☑
	POSICON (positioning control)							☑	☑	☑	☑
	24V power supply for control board (mandatory up to 10kW, optional above 15kW)		☑			☑			☑		☑
	PLC logic function									☑	☑
	Universal encoder interface									☑	☑
Synchronous motor operation									☑	☑	



# AC Vector Drives SK 500E

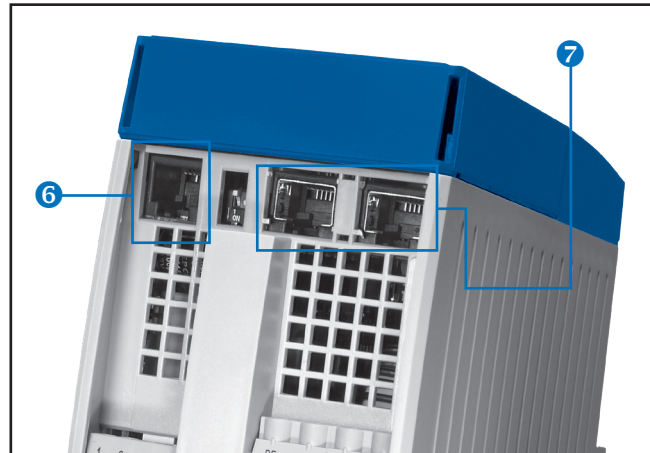
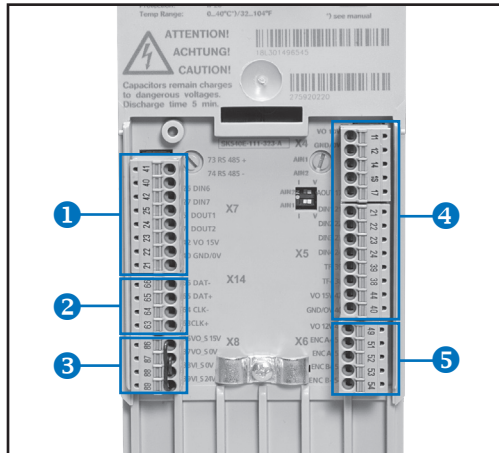

Interfaces	SK 500E	SK 505E	SK 510E	SK 511E	SK 515E	SK 520E	SK 530E	SK 535E	SK 540E	SK 545E
<b>4</b> 5x digital inputs 2x analog inputs (0...10V, 0/4...20mA) 1x analog output 2x multi-function relays RS 485 and RS 232 on RJ 12 socket	<input checked="" type="checkbox"/>	<input checked="" type="checkbox"/>	<input checked="" type="checkbox"/>	<input checked="" type="checkbox"/>	<input checked="" type="checkbox"/>	<input checked="" type="checkbox"/>	<input checked="" type="checkbox"/>	<input checked="" type="checkbox"/>	<input checked="" type="checkbox"/>	<input checked="" type="checkbox"/>
<b>5</b> 1x Incremental encoder input						<input checked="" type="checkbox"/>	<input checked="" type="checkbox"/>	<input checked="" type="checkbox"/>	<input checked="" type="checkbox"/>	<input checked="" type="checkbox"/>
<b>1</b> Additionally 2x digital inputs 2x digital outputs 1x RS 485 to terminal						<input checked="" type="checkbox"/>	<input checked="" type="checkbox"/>	<input checked="" type="checkbox"/>	<input checked="" type="checkbox"/>	<input checked="" type="checkbox"/>
Additional potential-isolated thermistor input					<input checked="" type="checkbox"/> (above Size 5)			<input checked="" type="checkbox"/> (above Size 5)		<input checked="" type="checkbox"/> (above Size 5)
External 24V supply for the control board		<input checked="" type="checkbox"/>			<input checked="" type="checkbox"/>			<input checked="" type="checkbox"/>		<input checked="" type="checkbox"/>
<b>3</b> Safety Function "Safe Stop"			<input checked="" type="checkbox"/>	<input checked="" type="checkbox"/>	<input checked="" type="checkbox"/>		<input checked="" type="checkbox"/>	<input checked="" type="checkbox"/>	<input checked="" type="checkbox"/>	<input checked="" type="checkbox"/>
<b>7</b> 2x RJ 45 for CANopen In/Out				<input checked="" type="checkbox"/>	<input checked="" type="checkbox"/> (above Size 5)	<input checked="" type="checkbox"/>	<input checked="" type="checkbox"/>	<input checked="" type="checkbox"/>	<input checked="" type="checkbox"/>	<input checked="" type="checkbox"/>
<b>6</b> 1x RJ 12 for operation and diagnosis	<input checked="" type="checkbox"/>	<input checked="" type="checkbox"/>	<input checked="" type="checkbox"/>	<input checked="" type="checkbox"/>	<input checked="" type="checkbox"/>	<input checked="" type="checkbox"/>	<input checked="" type="checkbox"/>	<input checked="" type="checkbox"/>	<input checked="" type="checkbox"/>	<input checked="" type="checkbox"/>
<b>2</b> Universal encoder interface									<input checked="" type="checkbox"/>	<input checked="" type="checkbox"/>

\* From Size 5 and above the analog inputs can also be used for +/- 10V signals



## SK 500E Rating and Voltage Matrix

kW (hp)	SK 500E				SK 505E				SK 510E				SK 511E				SK 515E			
	120V 1-	230V 1-	230V 3-	460V 3-	120V 1-	230V 1-	230V 3-	460V 3-	120V 1-	230V 1-	230V 3-	460V 3-	120V 1-	230V 1-	230V 3-	460V 3-	120V 1-	230V 1-	230V 3-	460V 3-
0.25 (0.33)						*	*													
0.37 (0.50)						*	*													
0.55 (0.75)						*	*	*												
0.75 (1.0)						*	*	*												
1.1 (1.5)						*	*	*												
1.5 (2.0)						*	*	*												
2.2 (3.0)						*	*	*												
3.0 (4.0)							*	*												
4.0 (5.0)							*	*												
5.5 (7.5)								*												⊗

□ 24VDC control voltage supply internal     
 \* 24VDC control voltage required from external source     
 ⊗ 24VDC control voltage supply internal or external

kW (hp)	SK 520E				SK 530E				SK 535E				SK 540E				SK 545E			
	120V 1-	230V 1-	230V 3-	460V 3-	120V 1-	230V 1-	230V 3-	460V 3-	120V 1-	230V 1-	230V 3-	460V 3-	120V 1-	230V 1-	230V 3-	460V 3-	120V 1-	230V 1-	230V 3-	460V 3-
0.25 (0.33)										*	*							*	*	
0.37 (0.50)										*	*							*	*	
0.55 (0.75)										*	*	*						*	*	*
0.75 (1.0)										*	*	*						*	*	*
1.1 (1.5)										*	*	*						*	*	*
1.5 (2.0)										*	*	*						*	*	*
2.2 (3.0)										*	*	*						*	*	*
3.0 (4.0)											*	*						*	*	
4.0 (5.0)											*	*						*	*	
5.5 (7.5)												*	*					*	*	⊗

□ 24VDC control voltage supply internal     
 \* 24VDC control voltage required from external source     
 ⊗ 24VDC control voltage supply internal or external



# AC Vector Drives SK 500E



## Step 1: SK 500E Inverter Selection

SK  Series  kW Rating  -  Input Voltage

1*	kW Rating
250	0.25 kW (0.33 hp)
370	0.37 kW (0.50 hp)
550	0.55 kW (0.75 hp)
750	0.75 kW (1.00 hp)
111	1.10 kW (1.50 hp)
151	1.50 kW (2.00 hp)
221	2.20 kW (3.00 hp)
301	3.00 kW (4.00 hp)
401	4.00 kW (5.00 hp)
551	5.50 kW (7.50 hp)
751	7.50 kW (10.00 hp)
112	11.0 kW (15 hp)
152	15.0 kW (20 hp)
182	18.5 kW (25 hp)
222	22.0 kW (30 hp)
302	30.0 kW (40 hp)
372	37.0 kW (50 hp)
452	45.0 kW (60 hp)
552	55.0 kW (75 hp)
752	75.0 kW (100 hp)
902	90.0 kW (125 hp)

E*	Input Voltage
112-O	100-120V, 1-phase (0.25 - 0.75 kW) (0.33 - 1.00 hp)
323-A	200-240V, 1-phase (0.25 - 2.20 kW) (0.33 - 3.00 hp)
323-A	200-240V, 3-phase (0.25 - 18.5 kW) (0.33 - 25.0 hp)
340-A	380-480V, 3-phase (0.55 - 90.0 kW) (0.75 - 125.0 hp)

E*	Series
500	Basic Unit
505	Basic Unit + 24V Operation*
510	Basic Unit + Safe Stop
511	Basic Unit + Safe Stop + CANopen
515	Basic Unit + 24V Operation* + Safe Stop + CANopen
520	Basic Unit + CANopen + Encoder + Extra I/O
530	Basic Unit + Safe Stop + CANopen + Encoder Input + Extra I/O + POSICON
535	Basic Unit + Safe Stop + CANopen + Encoder Input + Extra I/O + POSICON + 24V Operation*
540	Basic Unit + Safe Stop + CANopen + Encoder Input + Extra I/O + POSICON + Integrated PLC functionality + Universal Encoder Interface
545	Basic Unit + Safe Stop + CANopen + Encoder Input + Extra I/O + POSICON + Integrated PLC functionality + Universal Encoder Interface + 24V Operation*

\* Please Refer to the Rating and Voltage Matrix on page 923 to ensure the desired Series is available in the selected KW and Input Voltage Ratings that you have selected.

\* External 24V supply required on select ratings. Refer to the Rating and Voltage Matrix on page 923 for more detail.



## Step 2: Interface Module (Tech. Unit) Selection

Module Type  
**SK TU3** -

Module Type (Internal/External)
CTR - Control box programmer & display
PAR - Parameter box programmer & English display
POT - Speed potentiometer with star/stop and reverse direction
PBR - Profibus interface
PBR-24V - Profibus interface requiring external 24VDC supply
IBS - Interbus interface
CAO - CANopen interface
DEV - DeviceNet interface
AS1 - AS interface
ECT - Ethercat interface
PNT - Profinet interface
EIP - Ethernet/IP Interface
POL - Powerlink Interface

### Technology Units

Each SK 500E is equipped with a modular slot with re-movable cover. Here, a technology unit specific for the application can be added to program or control the unit, or to access the field bus system.

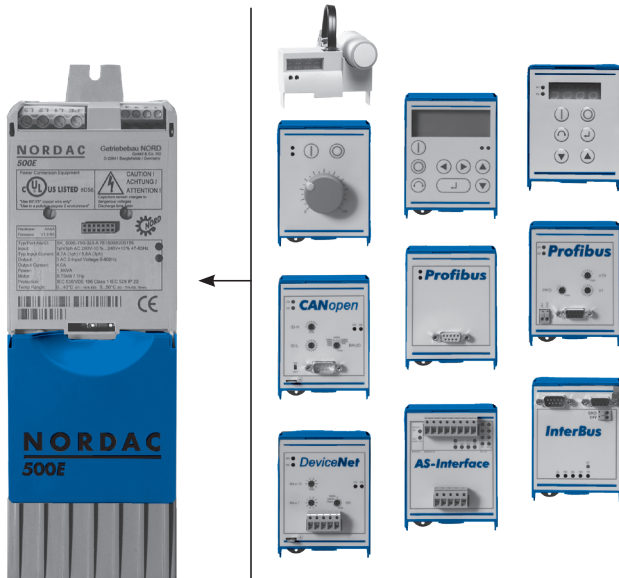

## Step 3: Dynamic Braking Resistor Selection

Model Type      R. Ohms      C. Rating  
**SK BR4** -  /

Model Type	Input Voltage	Drive Rating	Resistance Ohms	Continuous Rating
4: Footprint (SK 500E) (SK 505E) (SK 510E) (SK 511E) (SK 520E) (SK 530E) (SK 540E)	115/ 230V	0.25 - 0.37 kW	240	100
		0.55 - 0.75 kW	150	100
		1.1 - 2.2 kW	75	200
		3.0 - 4.0 kW	35	400
	460V	0.55 - 0.75 kW	400	100
		1.1 - 2.2 kW	210	200
		3.0 - 4.0 kW	100	400
		5.5 - 7.5 kW	60	600
2: Chassis (SK 515E) (SK 535E) (SK 545E)	230V	3.0 - 4.0 kW	35	400
		5.5 - 7.5 kW	22	600
		11.0 kW	12	1500
	460V	15.0 - 18.5 kW	9	2200
		3.0 - 4.0 kW	100	400
		5.5 - 7.5 kW	60	600
		11.0 - 15.0 kW	30	1500
		18.5 - 22.0 kW	22	2200
460V	30.0 - 37.0 kW	12	4000	
	45.0 - 55.0 kW	8	6000	
460V	75.0 - 90.0 kW	6	7500	

### Dynamic Braking Resistors

The SK 500E has options for bottom-mounted (footprint type) and external-mounted (chassis-type) dynamic braking resistors (DBR). A DBR is used for applications with regenerative loads such as lifting, cyclical, and high inertia loads. The DBR will dissipate the regenerative energy from the motor as heat using the internal brake chopper that is provided with the SK 500E.

Only the bottom-mounted dynamic braking resistors are shown in this selection guide. If a DBR for an AC vector drive that was selected is not shown in this guide, refer to the SK 500E operation manual BU 0500 GB for additional information.

The bottom-mounted DBRs are for general braking purposes. Larger DBRs may be required depending on the application parameters. Contact NORD for assistance with selecting the appropriate DBR.

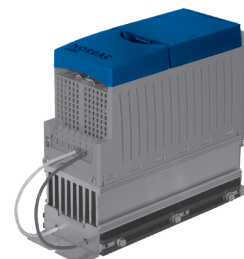

# AC Vector Drives SK 500E



## Step 4: Programmer/Operation Selection (recommended)

Module Type

**SK**

⑧

### ⑧ Programmer / Operator Type

CSX-3H - Handheld Simple Box (LED Display)
PAR-3H - Handheld Parameter Box (LCD English Display)
CSX 3E - Panel Mounted Simple Box (LED Display)
PAR-3E - Panel Mounted Parameter Box (LCD English Display)
CSX-0 - Simple Programmer and Display Mounted on top of SK500E
RJ12-SUB/D - PC Cable for NORDCON Software

A variety of programming and operation interfaces are available for the SK 500E. The SK PAR-3H (handheld) and SK PAR-3E (panel mount) provide programming, troubleshooting, and operation controls with an easy to use LCD English display. These modules have the capability of storing up to 5 different parameter sets for simple transfer of settings to other units.



SK PAR-3H



SK PAR-3E

The SK CSX-3H (handheld) and SK CSX-3E (panel mount) is used in a similar fashion as the SK PAR-3H and SK PAR-3E, but implements a bright, 4-digit 7-segment LED display.



SK CSX-3H



SK CSX-3E

With the use of Nord's RJ12-SUB/D cable, users may connect a SK 500E to a PC and configure it with NORDCON software. NORDCON is a Windows-based program that enables the user to program, upload/download parameter sets, troubleshoot with built in oscilloscope function, and control their AC vector drive.

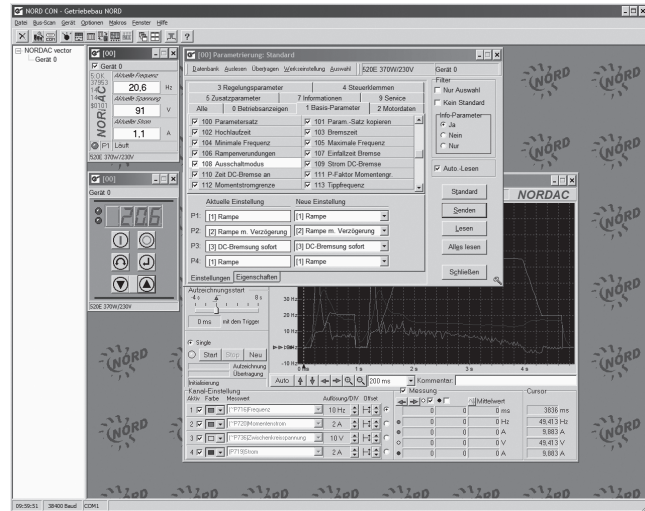

The CSX-0 is a simple programming and control tool that is installed on the top of the SK 500E and provides access to the drive settings and can be used as a local speed controller. An example of when this device may be used is when a field bus technology unit is already installed and the user would like a programming tool with speed readout also installed on the AC vector drive.



AC VECTOR DRIVES



## SK 500E General Specifications

Function	Specification
<b>Power / Voltage</b>	<ul style="list-style-type: none"> <li>1~110-120V +/-10%      0.33 - 1.0 hp      (0.25 - 1.1 kW)</li> <li>1~200-240V +/-10%      0.33 - 3.0 hp      (0.25 - 2.2 kW)</li> <li>3~200-240V +/-10%      0.33 - 25 hp      (0.25 - 18.5 kW)</li> <li>3~380-480V +/-10%      0.75 - 125 hp      (0.55 - 90.0 kW)</li> </ul>
<b>Input frequency rating tolerance</b>	47 - 63Hz
<b>Output frequency</b>	0 - 400Hz
<b>Pulse frequency</b>	3.0 - 16.0kHz, standard setting = 6kHz Power reduction > 8kHz for 115/230V device, > 6kHz for 400V device
<b>Rated overload capacity</b>	150% for 60 seconds, 200% for 5 seconds
<b>Protective measures against</b>	<ul style="list-style-type: none"> <li>• Overheating of the frequency inverter</li> <li>• Over/under-voltage</li> <li>• Short circuit, earthing fault</li> <li>• Over/underload, idling</li> </ul>
<b>Motor Turndown</b>	<ul style="list-style-type: none"> <li>• V/f Constant Torque 10:1</li> <li>• Sensorless Vector 30:1</li> <li>• Closed Loop Vector 1000:1</li> </ul>
<b>Motor temperature Monitoring</b>	Temperature sensor (PTC), temperature monitor (bimetal), I <sup>2</sup> t- motor
<b>Digital input</b>	5x, 7.5 - 30V (500E), 7x, 7.5 - 35V (520-530E)
<b>Control Methods</b>	<ul style="list-style-type: none"> <li>• V/f Constant torque</li> <li>• Energy saving mode</li> <li>• Sensorless Vector (ISD)</li> <li>• Closed-Loop Vector</li> </ul>
<b>Control outputs</b>	2x Digital output: 15V, 200mA maximum, 100kΩ load (520-530E) 2x Relay output: 230 VAC/24VDC, 24 Amp maximum
<b>Interfaces</b>	Standard: RS 485 (USS), RS 232 (single slave), System Bus Optional: Profibus, CANopen, DeviceNet, AS Interface, Interbus
<b>Energy Efficiency of AC drive</b>	Approximately 95% according to size
<b>Ambient temperature</b>	0 - 40°C (S1 - 100% ED), 0 - 50°C (S3 - 70% ED)
<b>Storage &amp; transport temp.</b>	-25 - 60 / 70°C
<b>Long term storage</b>	<ul style="list-style-type: none"> <li>• Connect the FI &amp; the 24V modules to the mains voltage for 60 min. before 1 storage year</li> <li>• Maintain this cycle throughout the storage period</li> </ul>
<b>Protection class</b>	IP20
<b>Maximum mounting altitude above sea level</b>	<ul style="list-style-type: none"> <li>• Up to 1000m – No power reduction</li> <li>• 1000 - 4000m – 1% per 100m power reduction (up to 2000m overvoltage cat.3)</li> <li>• 2000 - 4000m – Overvoltage cat. 2 is maintained, external overvoltage protection at the mains input is necessary</li> </ul>
<b>Waiting period between power-up cycles</b>	60 seconds for all devices in a normal operating cycle
<b>Accel / Decel Time</b>	0.0 - 320.0s
<b>Connection terminals</b>	<ul style="list-style-type: none"> <li>• Mains or motor / brake resistance - 25mm<sup>2</sup> with wiring sleeves, 35mm<sup>2</sup> with rigid cable</li> <li>• Control unit / system bus - 1.0mm<sup>2</sup> with wiring sleeves</li> <li>• Relay 1/2 - 1.5mm<sup>2</sup> with wiring sleeves (S1-4), 4.0 mm<sup>2</sup> with wiring sleeves (S5-7)</li> <li>• RS485 / RS232 - 1xRJ12 (6-pin)</li> <li>• CANbus/CANopen - 2x RJ45 (8-pin) (except SK 50xE and 510E)</li> </ul>
<b>Connection terminal screw tightening torque</b>	0.5 - 0.6 Nm
<b>External 24V supply voltage</b>	18...30V DC, at least 800-1000mA according to load (SK5x5E only)

# AC Vector Drives SK 500E



## SK 500E General Specifications

	Inverter type SK 5xxE...	Mains voltage	Output voltage	Nominal motor output	Nominal motor output	Nominal output current rms[A]	Typical input current rms[A]	Dim. L x B x D [mm]
				230 V [kW]	240 V [hp]			
<b>1 ~ 110 ... 120V</b>	-250-112-O	1 ~ 110...120V -/+10%. 47...63Hz	3 AC 0-220...240V	0.25	$\frac{1}{3}$	1.7	8	size1: 186 x 74 x 153
	-370-112-O			0.37	$\frac{1}{2}$	2.2	10	
	-550-112-O			0.55	$\frac{3}{4}$	3.0	13	
	750-112-O			0.75	1	4.0	18	

	Inverter type SK 5xxE...	Mains voltage	Nominal motor output	Nominal motor output	Nominal output current rms[A]	Typical input current rms[A]	Dimensions L x B x D [mm]
			400 V [kW]	480 V [hp]			
<b>1/3 ~ 200 ... 240V</b>	-250-323-A	1/3 ~ 200...240V -/+10%. 47...63Hz	0.25	$\frac{1}{3}$	1.7	3.7 / 2.4	size1: 186 x 74 x 153
	-370-323-A		0.37	$\frac{1}{2}$	2.2	4.8 / 3.1	
	-550-323-A		0.55	$\frac{3}{4}$	3.0	6.5 / 4.2	
	-750-323-A		0.75	1	4.0	8.7 / 5.6	
	-111-323-A		1.1	$1\frac{1}{2}$	5.5	12.0 / 7.7	size2: 226 x 74 x 153
	-151-323-A		1.5	2	7.0	15.2 / 9.8	
	-221-323-A		2.2	3	9.0	19.6 / 13.3	





## SK 500E General Specifications

	Inverter type SK 5xxE...	Mains voltage	Nominal motor output 400 V [kW]	Nominal motor output 480 V [hp]	Nominal output current rms[A]	Typical input current rms[A]	Dimensions L x B x D [mm]
<b>3 ~ 200 ... 240V</b>	-301-323-A	3 ~ 200...240V. -/+10%. 47...63Hz	3.0	4	12.5	17.5	size3: 241 x 98 x 178
	-401-323-A		4.0	5	16.0	22.4	

	Inverter type SK 5xxE...	Mains voltage	Nominal motor output 400 V [kW]	Nominal motor output 480 V [hp]	Nominal output current rms[A]	Typical input current rms[A]	Dimensions L x B x D [mm]
<b>3 ~ 380 ... 480V</b>	-550-340-A	3 ~ 380...480V -20%/+10%. 47...63Hz	0.55	$\frac{3}{4}$	1.7	2.4	Size 1: 186 x 74 x 153
	-750-340-A		0.75	1	2.3	3.2	
	-111-340-A		1.1	$1\frac{1}{2}$	3.1	4.3	Size 2: 226 x 74 x 153
	-151-340-A		1.5	2	4.0	5.6	
	-221-340-A		2.2	3	5.5	7.7	
	-301-340-A		3.0	4	7.5	10.5	Size 3: 241 x 98 x 174
	-401-340-A		4.0	5	9.5	13.3	
	-551-340-A		5.5	$7\frac{1}{2}$	12.5	17.5	Size 4: 286 x 98 x 174
	-751-340-A		7.5	10	16	22.4	

# AC Vector Drives SK 500E



## SK 500E AC Vector Drive Dimensions

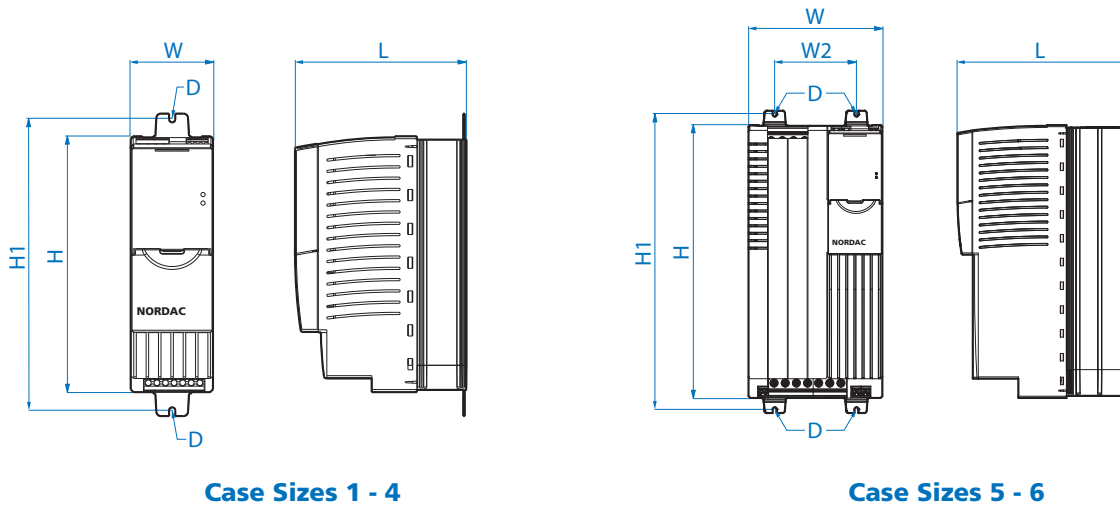

Case Sizes 1 - 4

Case Sizes 5 - 6

AC VECTOR DRIVES

Case Size	H	H1	L	W	W2	D	Weight
Case Size 1	7.32 [186 mm]	8.66 [220 mm]	6.02 [153 mm]	2.91 [74 mm]	-	ø0.216 [5.5 mm]	3.1 lb [1.4 kg]
Case Size 2	8.90 [226 mm]	10.24 [260 mm]	6.02 [153 mm]	2.91 [74 mm]	-	ø0.216 [5.5 mm]	4.0 lb [1.8 kg]
Case Size 3	9.49 [241 mm]	10.83 [275 mm]	7.13 [181 mm]	3.86 [98 mm]	-	ø0.216 [5.5 mm]	6.0 lb [2.7 kg]
Case Size 4	11.26 [286 mm]	12.60 [320 mm]	7.13 [181 mm]	3.86 [98 mm]	-	ø0.216 [5.5 mm]	6.8 lb [3.1 kg]
Case Size 5	12.76 [324 mm]	14.09 [358 mm]	8.82 [224 mm]	6.18 [157 mm]	3.66 [93 mm]	ø0.216 [5.5 mm]	17.6 lb [8.0 kg]



## Contact Information:

- North America
- Global

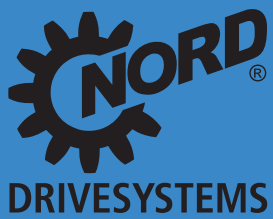

[www.nord.com](http://www.nord.com)

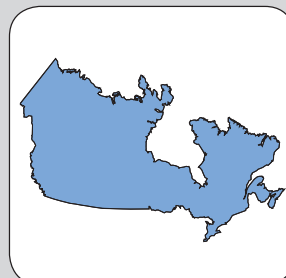
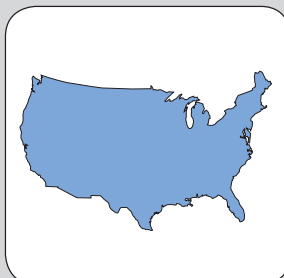

## United States

### **NORD Gear Corporation - Midwest Headquarters**

800 Nord Drive, P.O. 367  
Waunakee, WI 53597

toll free: 1-888-314-6673  
phone: 1-608-849-7300  
fax: 1-800-373-6673  
eMail: info.us@nord.com

### **NORD Gear Corporation - East**

300-E Forsyth Hall Drive  
Charlotte, NC 28273

toll free: 1-888-314-6673  
phone: 1-608-849-0140  
fax: 1-888-259-6673  
eMail: info.us@nord.com

### **NORD Gear Corporation - West**

1180 Railroad Street  
Corona, CA 92882

toll free: 1-888-314-6673  
phone: 1-608-849-0190  
fax: 1-888-408-6673  
eMail: info.us@nord.com

**For Sales office or distributors please contact us  
or see our website at [www.nord.com](http://www.nord.com)**

## Global Headquarters Germany

### **Getriebebau NORD GmbH & Co. KG**

Getriebebau-Nord-Straße 1  
22941 Bargteheide  
Germany

phone: +49-4532-2890  
Fax: +49 4532-289-2253  
eMail: info@nord.com

**For Sales office or distributors please contact us  
or see our website at [www.nord.com](http://www.nord.com)**

## Canada

### **NORD Gear Limited**

41 West Drive  
Brampton, Ontario L6T 4A1

toll free: 1-800-668-4378  
phone: 1-905-796-3606  
fax: 1-905-796-8130  
eMail: info.ca@nord.com

**For Sales office or distributors please contact us  
or see our website at [www.nord.com](http://www.nord.com)**

## Mexico

### **Mexico NORD Drivesystems SA DE CV**

Mexico Regional Office  
Av. Lázaro Cárdenas 1007 Pte.  
San Pedro Garza Garcia, N.L.  
México, C.P. 66266

phone: +52-81-8220-9165  
fax: +52-81-8220-9044  
eMail: info.mx@nord.com

**For Sales office or distributors please contact us  
or see our website at [www.nord.com](http://www.nord.com)**

## Nord Locator Tool

For international contacts (outside of North America), NORD makes it easy for you to locate address and phone number of the sales contact or facility nearest you on our homepage or with the web address: [www.locator.nord.com](http://www.locator.nord.com).



**SALES CONTACT** →

1 **Country**  
United States ▼

2 **or State search**  
please select a State ▼

3 **Distance**  
25 miles ▼

**Zip code**

**or Phone number search**  
(Include at least the first 6 digits)

It is as easy as submitting your location and we provide you with a list of our nearest district managers, distributors and plant locations for your convenience.

**NORD Office for**

**United States/Idaho** Print List

**NORD district manager(s) for Idaho**

<p><b>NORD Gear Corp</b> Scott Patzer 7645 E Amherst Ave Denver, CO 80231 Phone: 1-720-253-5371 Fax: 1-800-551-3732 E-Mail: <a href="mailto:scott.patzer@nord.com">scott.patzer@nord.com</a> Homepage: <a href="http://www.nord.com">http://www.nord.com</a></p>	<p><input type="button" value="Save VCard"/></p> <p><input type="button" value="Print"/></p>
<p><b>NORD Gear Corp</b> DuWayne Weber 2201 33rd Ave Ct SW Puyallup, WA 98373-4011 Phone: 1-253-380-2150 Fax: 1-800-564-3707 E-Mail: <a href="mailto:duwayne.weber@nord.com">duwayne.weber@nord.com</a> Homepage: <a href="http://www.nord.com">http://www.nord.com</a></p>	<p><input type="button" value="Save VCard"/></p> <p><input type="button" value="Print"/></p>

**NORD plant for Idaho**

<p><b>NORD Gear Corp - West</b> 1180 Railroad St Corona, CA 92882 Phone: 1-888-314-6673 Fax: 1-988-408-6673 E-Mail: <a href="mailto:info.us@nord.com">info.us@nord.com</a> Homepage: <a href="http://www.nord.com">http://www.nord.com</a></p>	<p><input type="button" value="Save VCard"/></p> <p><input type="button" value="Google Maps"/></p> <p><input type="button" value="Print"/></p>
--	--

**Distributors Idaho**

<p><b>Bearings &amp; Industrial Sales Inc</b> 625 Lindsay Blvd Idaho Falls, ID 83402 Phone: 1-208-522-0266 Fax: 1-208-522-0272</p>	<p><input type="button" value="Print"/></p>
--	---



[www.nord.com](http://www.nord.com)

G1014 – Subject to Change Without Notice

265

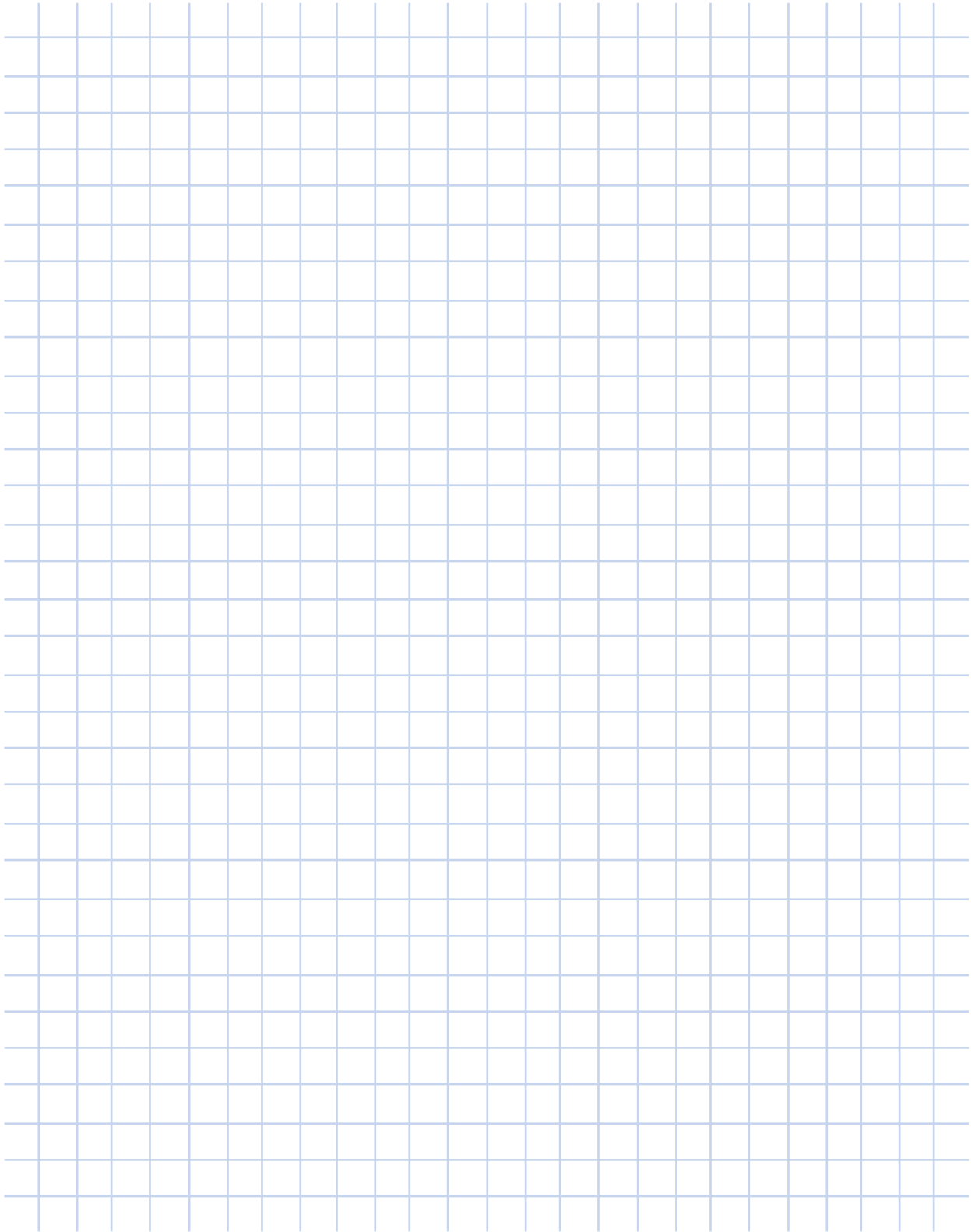

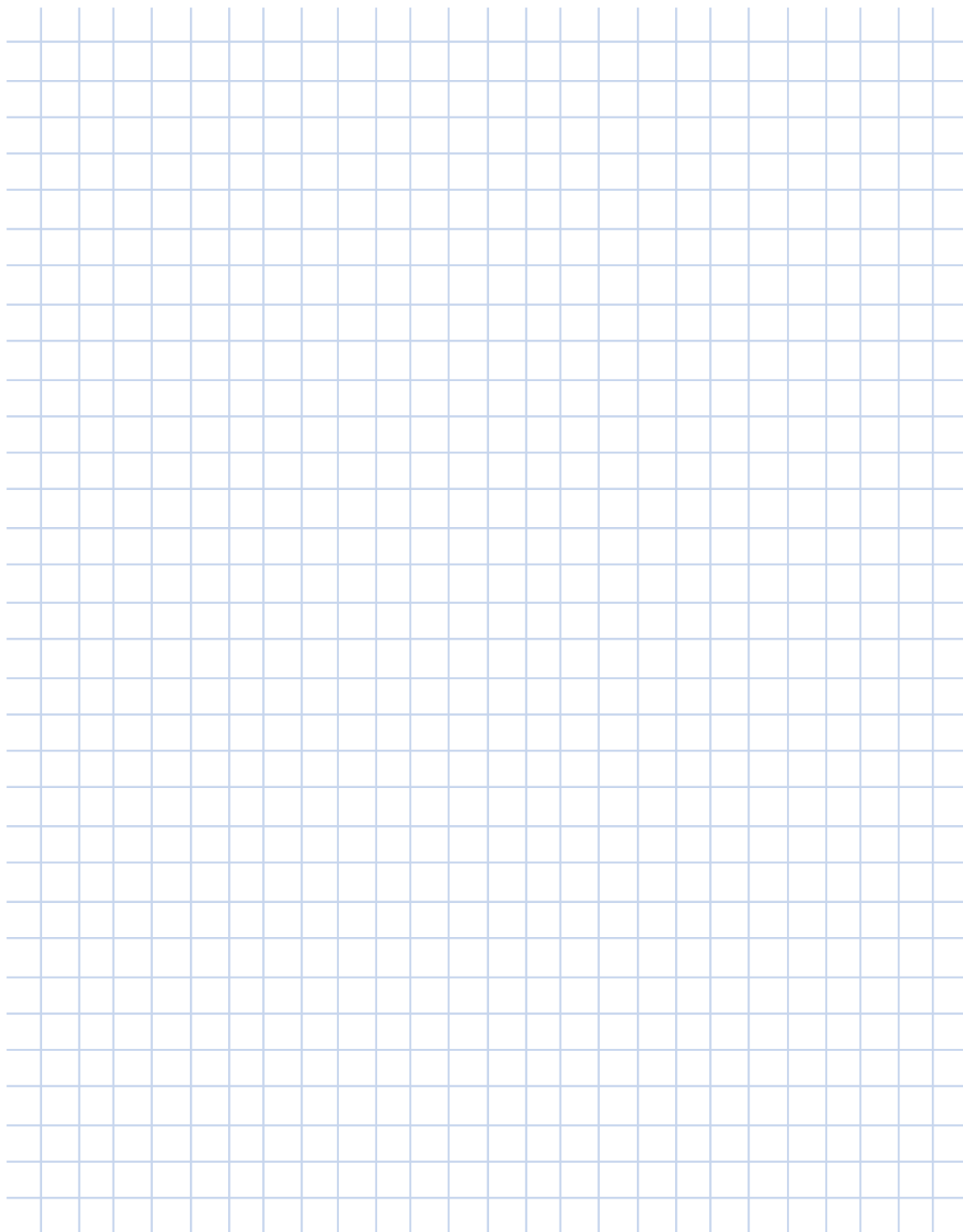

A large grid area for taking notes, consisting of 20 columns and 30 rows of light blue lines.



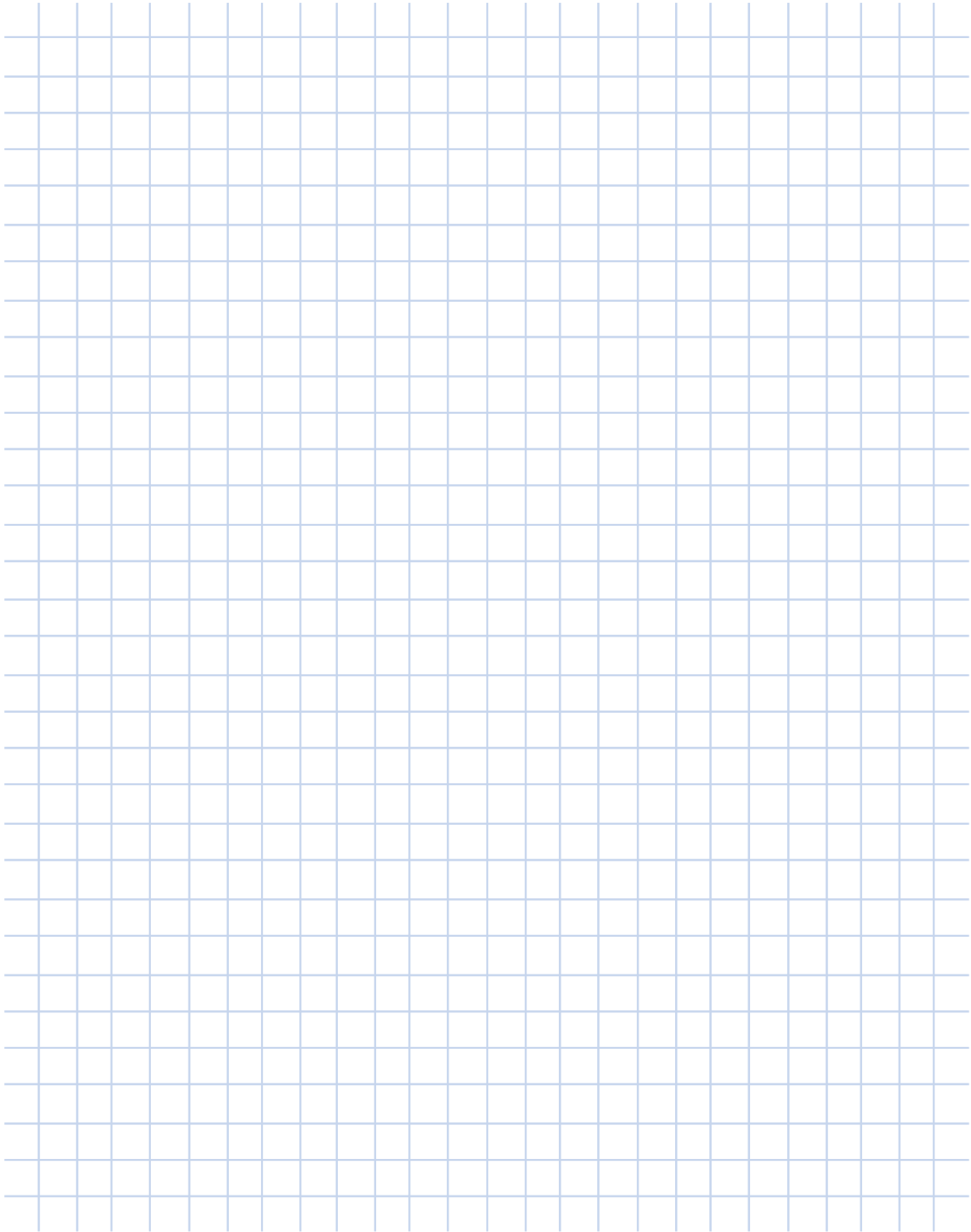

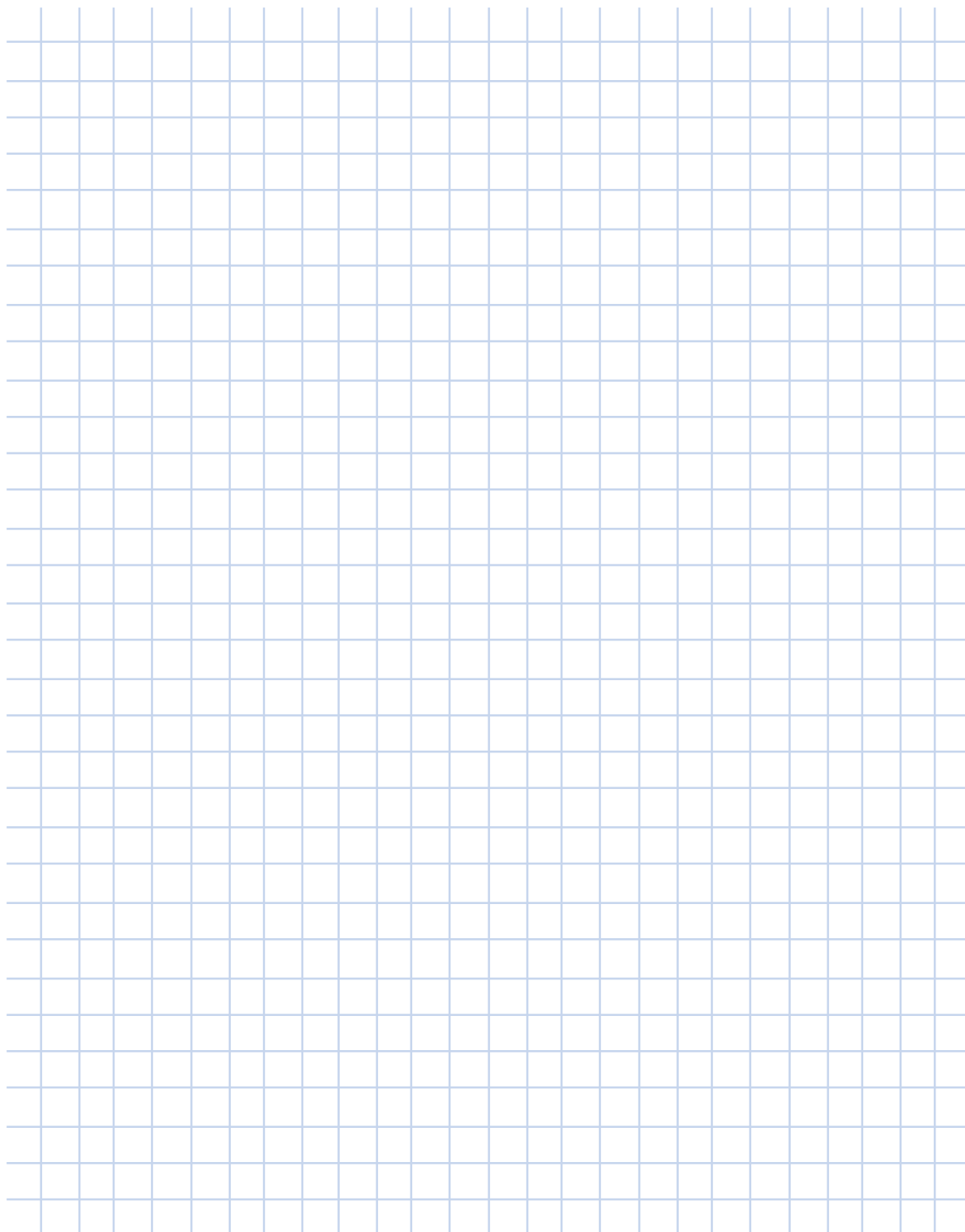



# NORD GEAR LIMITED

## Terms and Conditions of Sale

### 1. CONTRACT

Any contract between Nord Gear Limited, hereinafter designated as "Seller", and the party or parties accepting these terms and conditions of sale and any agent, officer, servant, employee or subcontractor of such party or parties, hereinafter designated as "Buyer", is subject to the terms and conditions of sale hereinafter set forth. Any deviation from such terms and conditions must be specifically set forth in writing and consented to by Seller.

### 2. CONFIRMATION

An order shall be deemed accepted only when duly confirmed by Seller, at Nord Gear Limited's home office in Brampton, Ontario, and upon such confirmation the orders shall become a contract binding upon the parties hereto, their successors and assigns.

### 3. PRICES

Prices shown are list prices and may be subject to applicable discounts. Unless otherwise agreed upon in writing, prices are FOB factory Brampton, Ontario. Prices and discounts are subject to change without notice until the order is accepted. Seller's prices do not include cost of any inspection permits required.

### 4. LIMITED WARRANTY

Seller warrants the goods sold hereunder to be free from defects in material and workmanship under normal use and service not arising from misuse, negligence, or accident, including but not limited to the use, installation, and transportation of the goods by Buyer, its agents, servants, employees, or by carriers. This warranty shall pertain to any part or parts of any goods to which Buyer or its assigns has within one year from date of delivery given written notice of claimed defects to Seller. Buyer shall be required to furnish Seller with details of such defects and this warranty shall be effective as to such goods which Seller's examination shall disclose to its satisfaction to have been defective and which at Seller's option shall promptly thereafter be returned to Seller or its nominees. EXCEPT FOR THE EXPRESS WARRANTIES SET FORTH ABOVE, SELLER HAS MADE NO WARRANTIES, EXPRESS, IMPLIED OR STATUTORY, AS TO THE GOODS SOLD HEREUNDER, INCLUDING, BUT NOT LIMITED TO THEIR MERCHANTABILITY OR FITNESS FOR ANY PARTICULAR PURPOSE. ANY DESCRIPTION OR MODEL OF THE GOODS IS FOR IDENTIFICATION OR ILLUSTRATIVE PURPOSES ONLY AND SHALL NOT BE DEEMED TO CREATE AN EXPRESS WARRANTY. The Buyer's exclusive remedy for claims arising from defective or nonconforming goods shall be limited to the repair or replacement thereof at the Seller's sole option. THE SELLER SHALL NOT BE RESPONSIBLE OR LIABLE FOR CONSEQUENTIAL DAMAGES ARISING OUT OF OR IN CONNECTION WITH THE SALE, DELIVERY, USE, PERFORMANCE, OR SERVICE OF THE GOODS SOLD UNDER THIS AGREEMENT. SELLER SHALL NOT BE LIABLE FOR ANY LOST PROFITS OR FOR ANY CLAIM OR DEMAND AGAINST SELLER BY ANY PARTY. IN NO EVENT WILL SELLER BE LIABLE FOR SPECIAL, INDIRECT OR CONSEQUENTIAL DAMAGES, EVEN IF SELLER HAS BEEN ADVISED OF THE POSSIBILITY OF SUCH DAMAGES. SELLER'S AGGREGATE LIABILITY FOR DAMAGES UNDER THIS AGREEMENT, WHETHER ARISING FROM OR BASED UPON BREACH OF WARRANTY, BREACH OF CONTRACT, TORT OR OTHER CAUSE OF ACTION, SHALL IN NO CASE EXCEED THE PURCHASE PRICE THAT BUYER PAYS FOR THE PARTICULAR GOODS INVOLVED. Seller shall in no event be liable to any person or firm (including any assignee or Buyer) except Buyer and its successors. Unless specifically authorized by Seller in writing, Seller shall not become responsible for any repair work done by Buyer or any other party on any goods sold. Any costs of the return of such goods to Seller shall be borne by Buyer. Goods sold but not manufactured by Seller are being warranted as to defects in material and workmanship consistent with the limited warranty policy of the original manufacturer of the goods and if there is not such a limited warranty policy, the warranty shall be limited to the provisions of Article 4 herein. Standards for the operating characteristics of the gearboxes and the gear motors are in conformity with Seller's tests. THIS WARRANTY IS IN LIEU OF ALL OTHER EXPRESS OR IMPLIED WARRANTIES, INCLUDING ANY IMPLIED WARRANTY OF MERCHANTABILITY OR FITNESS FOR ANY PARTICULAR PURPOSE SELLER DOES NOT ASSUME, NOR DOES IT AUTHORIZE ANY PERSON TO ASSUME, ON ITS BEHALF, ANY OTHER OBLIGATION OR LIABILITY.

### 5. SHORTAGE AND NONCONFORMITY

Any claim of shortage or that the goods do not conform with the specifications of the order or model must be made in writing within ten (10) days after delivery of the goods (as to which such claim is made) to Buyer or its nominees, but in no event shall the claim be later than within the time limit provided by the carrier or insurance company, otherwise such claim shall be deemed waived. The samples, measurements, dimensions and weights contained in Seller's catalogs, sales manuals, photographs and drawings constitute only an approximate guide. Seller reserves the right to make any changes which Seller, in its absolute discretion, considers necessary. While the goods will be delivered principally according to specifications of standards or quantities agreed upon, insignificant deviations or insignificant changes in construction are permissible. The same applies to partial deliveries. In the event that Buyer has a verified claim of shortage or nonconformity of the goods to the specifications of the order or the model, and if such claim has been submitted within the required time limit as set forth above, Seller shall, at its own expense, make up for the shortage of the goods, or replace or repair the goods, as the cause may be, but in no event shall Seller be or become liable to Buyer or to any other person or persons for any loss in damage, direct or indirect, arising out of or caused by such incidents or for the loss of profits, business of good will. Shipping dates are estimates unless parties expressly agree on time of the essence.

### 6. FORCE MAJEURE

The obligation of Seller shall be modified or excused, as the case may be, for reasons of Acts of God, war, governmental law regulations, strikes or lock-outs, fire, breakdown of machinery, whether in its own business enterprise, or if for any other cause beyond Seller's control, the goods cannot be delivered or their delivery becomes delayed in whole or in part. In the above instances time for delivery shall be extended for the period of the delay caused, with the proviso, however, that either party may cancel in writing the undelivered portion of the order of contract if the delay exceeds six (6) months from the delivery date originally confirmed by Seller. In no event shall Seller become liable in the aforesaid instances to Buyer or any third party for consequential damages or business loss.

### 7. SHIPMENT AS UNIT

Each shipment by Seller shall be treated as a separate and distinct unit with respect, but only with respect to forwarding, terms of payment, and the making of claims by Buyer, provided, however, that if Buyer defaults in the payment of any obligation to Seller or any installments thereof, under any agreement between Buyer and Seller, or if Buyer refuses to accept any goods when tendered for delivery, Seller may, on fifteen (15) days written notice to Buyer, without prejudice to Seller's other lawful remedies, either defer further performance until the defaulted payments are made in full, or make future deliveries for cash in advance only, or to treat the entire contract or contracts with Buyer as breached by Buyer and pursue its remedies for breach.

### 8. BUYER'S REFUSAL OF DELIVERY

If Buyer refuses to accept delivery of any goods tendered for delivery, then Seller, without prejudice to Seller's other lawful remedies, may either store or cause such goods to be stored in a warehouse, for Buyer's account and at Buyer's cost, risk and expense, or sell such goods (without notice) to any purchaser at public or private sale, and hold Buyer liable for any difference between (A) the contract price of the goods, and (B) the price at which goods are resold less the costs and expense of such resale including brokerage commissions, or restocking charges.

### 9. GOODS IN TRANSIT

If prior to delivery or while the goods are in transit, Buyer or Seller becomes bankrupt or insolvent, or any petition in bankruptcy or for the reorganization or for appointment of a receiver is filed against Buyer or Seller, as the case may be, then the other party hereto may forthwith terminate this contract by giving written notice of such termination. Such termination shall not affect any claim for damages available to Buyer, to Seller, as actually paid in money, is abated by any order of judgment entered or any plan adopted in any bankruptcy, reorganization, receivership, or similar proceeding. Such termination shall not prejudice Seller's rights to any amounts then due under the contract. If Buyer becomes bankrupt or insolvent or any petition in bankruptcy or for reorganization or if a state court receivership is filed against Buyer, then, at its option, Seller may take possession of any goods theretofore sold to Buyer, in connection with which the full purchase price has not been paid, analogous to the terms and provisions set forth in Paragraphs 11 and 12 hereinafter.

### 10. DELIVERY

(A) Unless otherwise agreed, delivery of the goods to any carrier shall constitute delivery to Buyer, and thereafter the risk of loss or damage to the goods shall be upon Buyer. (B) If Buyer does not give delivery instructions to Seller at least ten (10) days prior to the delivery date ex factory confirmed by Seller, Seller may deliver the goods to a carrier of its own choosing, at Buyer's cost and risk, or, at Seller's option may store the goods on the pier or on any warehouse at Buyer's cost and risk. Any purchase price in such event becomes due and payable within ten (10) days of such storage.

### 11. PAYMENT OF PURCHASE PRICE

Time of payment is of the essence under the contract. Upon default in any of the terms of the contract, or failure to comply with any of the conditions thereof, or upon seizure of the property under execution or other legal process, or if Buyer becomes bankrupt or insolvent, or any petitions for reorganization or for appointment of a receiver is filed against Buyer, or if Buyer makes any assignment for the benefit of its creditors or otherwise sells, encumbers or disposes of the goods, or if for any other reason Seller should deem itself insecure, the full amount of the purchase price then remaining unpaid shall at once become due and payable at the option of Seller. Interest on the delinquent payment from the due date thereof until paid shall be at a rate of two (2%) percent per month.

### 12. BUYER'S DEFAULT

Upon Buyer's default, Seller may dispose of the merchandise in any manner that it deems fit and, if it desires to resell same, may do so at private or public sale, with or without notice, and with or without the property being at the place of sale, subject, however, to applicable laws. Seller or its assigns shall have the right to bid at such sale and may become the purchaser of the property. The proceeds of the sale shall first be applied to the expenses incurred in retaking, repairing, storing and selling the goods; reasonable solicitor's fees included, and then shall be applied to the payment of the balance due under the contract. Any surplus amount shall be paid to Buyer. If a deficiency results after the sale, Buyer agrees to pay such forthwith, together with reasonable solicitor's fees, for the recovery of the goods incurred by Seller. If upon Buyer's default, Seller elects not to resell any goods which it may repossess, then the cost of repossession, including reasonable solicitor's fees, shall forthwith be due and payable from Buyer to Seller.

### 13. SECURITY INTEREST AND TITLE

In provinces which are governed by a Personal Property Security Act, this contract shall serve as a security agreement, reserving in Seller a security interest until full payment of the purchase price. The provisions of the Personal Property Security Act regarding security interest shall have preference and apply if inconsistent with other terms of the conditions of sale herein. In provinces where a Personal Property Security Act does not apply, title to the goods shall remain in the Seller or its assigns until full payment of the purchase price. Buyer agrees to execute forthwith any and all documents in such a way and form as Seller may need for filing or recording the security interest under a Personal Property Security Act with the proper registers or offices, or for filing or recording the Conditional Sales Contract herein.

### 14. SALES AND USE TAX

Seller's prices do not include sales, use, excise or other taxes payable to any governmental authority in respect of the sale of Seller's goods. Buyer shall pay, in addition to Seller's price, the amount of any such taxes or shall reimburse Seller for the amount thereof that Seller may be required to pay. At the option of Seller, Buyer shall give evidence of payment or of exemption certificate.

### 15. INSURANCE

Buyer shall keep the goods insured against damage by fire, water or other casualty as required by Seller, with a company acceptable to Seller, with loss payable to Seller for the total purchase price until Seller is fully paid. Seller, if it so elects, may place said insurance at Buyer's expense; Seller may cancel such insurance at any time and without notice and may receive the return premium, if any.

### 16. MODIFICATION BY SELLER

Any contract may be assigned or transferred by Seller, or the time for the making of any payment due by Buyer may be extended by Seller without derogation of any of the rights of Seller or its assigns. Waiver by any party of any default shall not be deemed a waiver of any subsequent default.

### 17. RETURNED GOODS

No goods will be accepted for return unless authorized in writing by Seller. In all cases, transportation and restocking charges will be borne by Buyer.

### 18. PACKING

Seller does not charge for standard packaging for domestic shipment. Buyer will be charged, however, for export packaging or other special packing desired. Cost for cartage to ship or transfer express will be added to the invoice. No credit will be allowed if no packing is required.

### 19. EXPORT ORDER

Export orders are to be accompanied by a confirmed irrevocable Letter of Credit in Seller's favor, in Canadian currency, with an accredited Canadian bank, subject to Seller's draft, with shipping documents attached.

### 20. CANCELLATION

Placing orders on hold or cancellation of orders require Seller's written approval, and are subject to cancellation and/or restocking charges.

### 21. BUYER'S RESPONSIBILITY AS TO MAINTENANCE

Buyer shall use and shall require its employees and agents to use all safety devices and guards and shall maintain the same in proper working order. Buyer shall use and require its employees and agents to use safe operating procedures in operating the equipment and shall further obey and have its employees and agents obey safety instructions given by Seller. If Buyer fails to meet the obligations herein, Buyer agrees to indemnify and save Seller harmless from any liability or obligation with regard to any personal injuries or property damages directly or indirectly connected with the operation of the equipment. Buyer further agrees to notify Seller promptly and in any event not later than ten (10) days after notice or knowledge of any accident or malfunction involving Seller's equipment which has caused personal injury or property damages and to cooperate fully with Seller in investigating and determining the causes of such accident and malfunction. In the event that Buyer fails to give such notice to Seller or to cooperate with Seller, Buyer shall be obligated to indemnify and save Seller harmless from any such claims arising from such accident.

### 22. MISCELLANEOUS PROVISIONS

(A) If for any reason a provision of a contract is legally invalid, then in such event the rest of the contract shall remain in full force and effect, except that the parties shall try to replace such invalid provision with a provision closest to their original mutual intentions. (B) Any amendments to any contract or contracts require the consent in writing by both parties. Headings in this document are for ease of reference only.

### 23. NON ASSIGNMENT BY BUYER

Contract or contracts may not be assigned by Buyer without prior written consent of Seller.

### 24. APPLICABLE LAW

This agreement shall be governed by the laws of the Province of Ontario and the applicable laws of Canada. Buyer and Seller agree that any judicial proceeding with respect to this agreement must be brought and maintained in the City of Toronto, in the Province of Ontario.

### 25.

This instrument sets forth the entire understanding and agreement of the parties hereto in respect of the subject matter hereof, and all prior undertaking between the parties hereto, together with all representations and obligations of such parties in respect of such subject matter, shall be superseded by and merged into this instrument.

### 26.

The provisions of this agreement shall bind and ensure to the benefit of the parties hereto and their respective heirs, executors, administrators, successors and (subject to any restrictions or assignment herein above set forth) assigns, as the case may be.

### 27.

The parties acknowledge that they have requested this document and all notices or other documents relating thereto be drafted in the English language.

Les parties reconnaissent qu'ils ont requis que ce contrat et tous les avis ou autres documents qui s'y rapportent soient rédigés en langue anglaise.

\*Terms and Conditions in French available upon request.\*



DRIVESYSTEMS

# NORD GEAR CORPORATION



WWW.NORD.COM

## CONDITIONS OF SALE

### 1. CONTRACT

Any contract between Nord Gear Corporation, hereinafter designated as Seller, and the Buyer is subject to the terms and conditions of sale hereinafter set forth. Any deviation from such terms and conditions must be specifically set forth in writing and consented to by Seller. Accordingly, the Buyer and Seller acknowledge and agree that the terms and conditions set forth below and on the face hereof shall govern Buyer's purchase of the goods described on the face hereof and shall take precedence over and represents the final agreement between Buyer and Seller, notwithstanding any inconsistent, contradictory or other prior or further conditions contained in any oral or written request or purchase order issued by Buyer or any other document furnished by Buyer in connection with its purchase of the Goods, regardless of whether such document or documents are exchanged simultaneously with this Invoice or prior or subsequent thereto. Any additional or different terms or conditions which may appear in any communication, oral or written, from Seller, its officers, employees, agents or representatives, are hereby expressly rejected and shall not be effective or binding upon the Seller, unless specifically hereafter agreed to in writing by Seller and no such additional or different terms or conditions in any document submitted to Seller by Buyer shall become part of the contract between Buyer and Seller, unless such written acceptance by Seller specifically recognizes and assents to their inclusion. Any objection by Buyer to the terms and conditions hereof shall be ineffective unless Seller is advised in writing thereof within two (2) days of the date of this Invoice.

### 2. CONFIRMATION

An order shall be deemed accepted only when duly confirmed by Seller, at Nord Gear Corporation's home office in Waunakee, Wisconsin, and upon such confirmation the order shall become a contract binding upon the parties hereto, their successors and assigns.

### 3. PRICES

Prices shown are list prices and may be subject to applicable discounts. Unless otherwise agreed upon in writing, prices are FOB factory Waunakee, Wisconsin. Prices and discounts are subject to change without notice until order is accepted. Seller's prices do not include cost of any inspection permits required.

### 4. LIMITED WARRANTY

Seller hereby warrants that the goods sold hereunder shall be free from material defects in material and workmanship, if properly installed and used under normal operating conditions, for a period of twelve (12) months from the date of installation or eighteen (18) months from date of shipment, whichever comes first (the "Warranty Period"). With respect to gears and housings only, the Warranty Period is extended to thirty-six (36) months from the date of invoice or twenty-four (24) months from the date of installation, whichever comes first. The limited warranty shall not apply to any components or parts which are subject to normal operational wear and tear, including, but not limited to, belts and traction discs. Should any goods fail to comply with the foregoing limited warranty, Buyer shall provide written notice to Seller of the claimed defect and all relevant details within thirty (30) days of Buyer's discovery of the claimed defect. Buyer shall return the allegedly defective goods to Seller at its facilities in Waunakee, Wisconsin or to such other location within the USA as may be designated by Seller in its sole discretion, with all shipping and transportation charges prepaid by Buyer. Seller shall then examine the returned goods to determine if the claimed defect is covered by the limited warranty. If the claimed defect is covered by the limited warranty, Buyer's sole and exclusive remedy shall be to have Seller repair or replace, at Seller's option, the defective goods or components in accordance with the terms of this limited warranty. Seller shall have a commercially reasonable time to make such repairs or replacements and may use new or reconditioned components. Any repair or replacement shall not extend the Warranty Period unless otherwise agreed by Seller. Buyer shall pay all shipping costs and any costs of removal and re-installation of goods or components.

The foregoing limited warranty shall not apply with respect to any goods or components (i) which are not installed, used, operated, serviced or maintained in accordance with manufacturer's instructions or which are otherwise not properly installed, used, operated, serviced or maintained, or (ii) which are misused, neglected, damaged, altered, repaired, reconfigured or incorrectly wired. Seller makes no representations as to the specifications, capacity or performance of the goods sold hereunder, except as may be specifically set forth in the invoice's written specifications, and any such representations are expressly conditioned upon the accuracy and completeness of the data and information furnished by the buyer and upon the goods being properly installed, used, serviced and maintained by Buyer. Any description or model of the goods is for identification or illustrative purposes only and shall not be deemed to create any warranty, express or implied.

THE FOREGOING LIMITED WARRANTY SHALL EXTEND SOLELY TO BUYER AND NOT TO ANY OTHER PARTY. THE FOREGOING LIMITED WARRANTY IS IN LIEU OF ANY AND ALL OTHER WARRANTIES, WHETHER EXPRESS OR IMPLIED. SELLER HEREBY EXCLUDES AND DISCLAIMS ANY AND ALL OTHER WARRANTIES, WHETHER EXPRESS OR IMPLIED, INCLUDING, WITHOUT LIMITATION, ANY IMPLIED WARRANTIES OF MERCHANTABILITY OR FITNESS FOR A PARTICULAR PURPOSE. IF BUYER SHALL FAIL TO PAY WHEN DUE ANY PORTION OF THE PURCHASE PRICE OR ANY OTHER PAYMENT REQUIRED FROM BUYER TO SELLER UNDER THIS CONTRACT, ALL WARRANTIES AND REMEDIES SET FORTH HEREIN SHALL BE DEEMED NULL AND VOID, AB INITIO. THE PARTIES ACKNOWLEDGE AND AGREE THAT THE EXCLUSIVE REMEDY UNDER THE FOREGOING LIMITED WARRANTY SHALL NOT HAVE FAILED OF ITS ESSENTIAL PURPOSE (AS THAT TERM IS USED IN THE UNIFORM COMMERCIAL CODE) PROVIDED THAT SELLER REMAINS WILLING TO REPAIR OR REPLACE DEFECTIVE GOODS WITHIN A COMMERCIALY REASONABLE TIME. BUYER SPECIFICALLY ACKNOWLEDGES AND AGREES THAT THE PRICE CHARGED BY SELLER FOR THE GOODS IS BASED UPON THE LIMITATIONS OF SELLER'S WARRANTY OBLIGATIONS AND OTHER LIABILITIES AS SET FORTH HEREIN.

LIMITATION OF LIABILITY. NOTWITHSTANDING ANY OTHER PROVISION HEREOF, IN NO EVENT SHALL SELLER BE LIABLE TO BUYER OR TO ANY OTHER PARTY FOR ANY INCIDENTAL, SPECIAL, INDIRECT OR CONSEQUENTIAL DAMAGES, LOST PROFITS, OR FOR ANY LOSSES, CLAIMS OR DAMAGES RELATING TO OR ARISING FROM THE USE OR OPERATION OF THE GOODS, AND IN NO EVENT SHALL ANY CLAIM OR RECOVERY OF ANY KIND EXCEED THE PURCHASE PRICE OF THE GOODS IDENTIFIED IN THE RELATED INVOICE.

### 5. SHORTAGE AND NONCONFORMITY

Any claim of shortage or that the goods do not conform with the specifications of the order or model must be made in writing within ten (10) days after delivery of the goods (as to which such claim is made) to Buyer or its nominee, but in no event shall the claim be later than within the time limit provided by the carrier or insurance company, otherwise such claim shall be deemed waived. Buyer may not return any goods claimed to be in non-conformity without Seller's prior written authorization. Goods returned without permission will not be accepted, including for credit, and will be returned to Buyer, F.O.B. Seller's plant. Any claim based on the receipt of damaged Goods must be filed with the carrier which delivered the goods. The samples, measurements, dimensions and weights contained in the Seller's catalogs, sales manuals, photographs and drawings constitute only an approximate guide. The Seller reserves the right to make any change which the Seller, in its absolute discretion, considers necessary. While the goods will be delivered principally according to specifications or standards or quantities agreed upon, insignificant deviations or insignificant changes in construction are permissible. The same applies to partial deliveries. In the event that Buyer has a verified claim of shortage or nonconformity of the goods to the specifications of the order or the model, and if such claim has been submitted within the required time limit as set forth above, the Seller shall, at its own expense, make up for the shortage of the goods, or replace or repair the goods, as the case may be, but in no event shall Seller be or become liable to Buyer or to any other person or persons for any loss in damage, direct or indirect, arising out of or caused by such incidents or for the loss of profits, business or good will. The liability of the Seller to Buyer, if any hereunder, for breach of warranty, contract, negligence or otherwise, shall in no event exceed the amount of the purchase price of the goods sold with respect to which any damages are claimed. Shipping dates are estimates unless parties expressly agree on time of the essence.

### 6. FORCE MAJEURE

The obligation of the Seller shall be modified or excused, as the case may be, for reasons of Acts of God, war, governmental law regulations, strikes or lock-outs, fire, breakdown of machinery, whether in its own business enterprise, or if for any other cause beyond Seller's control, the goods cannot be delivered or their delivery becomes delayed in whole or in part. In the above instances time for delivery shall be extended for the period of the delay caused, with the proviso, however, that either party may cancel in writing the undelivered portion of the order or contract if the delay exceeds six (6) months from the delivery date originally confirmed by Seller. In no event shall Seller become liable in the aforesaid instances to Buyer or any third party for consequential damages or business loss.

### 7. SHIPMENT AS UNIT

Each shipment by Seller shall be treated as a separate and distinct unit with respect, but only with respect to forwarding, terms of payment, and the making of claims by the Buyer: provided, however, that if the Buyer defaults in the payment of any obligation to Seller or any installments thereof, under any agreement between Buyer and Seller, or if Buyer refuses to accept any goods when tendered for delivery, the Seller may, on fifteen (15) days written notice to the Buyer, without prejudice to Seller's other lawful remedies, either defer further performance until the defaulted payments are made in full, or make future deliveries for cash in advance only, or treat the entire contract or contracts with Buyer as breached by the Buyer and pursue its remedies for breach.

### 8. BUYER'S REFUSAL OF DELIVERY

If Buyer refuses to accept delivery of any goods tendered for delivery, then Seller, without prejudice to Seller's other lawful remedies, may either store or cause such goods to be stored in a warehouse, for Buyer's account and at Buyer's cost, risk and expense, or sell such goods (without notice) to any purchaser at public or private sale, and hold the Buyer liable for any difference between (a) the contract price of the goods, and (b) the price at which goods are resold less the costs and expense of such resale including brokerage commissions, or restocking charges.

### 9. GOODS IN TRANSIT

If prior to delivery or while the goods are in transit, Buyer or Seller becomes bankrupt or insolvent, or any petition in bankruptcy or for the reorganization or for a state court receivership is filed against Buyer or Seller, as the case may be, then the other party hereto may forthwith terminate this contract by giving written notice of such termination. Such termination shall not affect any claim for damages available to the Buyer, provided that if Buyer is then indebted to Seller, the amount of any such damage claim shall be abated to the extent that the indebtedness of Buyer to Seller, as actually paid in money, is abated by any order of judgement entered or any plan adopted in any bankruptcy, reorganization, receivership, or similar proceeding. Such termination shall not prejudice the Seller's rights to any amounts then due under the contract. If Buyer becomes bankrupt or insolvent or any petition in bankruptcy or for reorganizing or if a state court receivership is filed against Buyer, then, at its option Seller may take possession of any goods theretofore sold to Buyer, in connection with which the full purchase price has not been paid, analogous to the terms and provisions set forth in Paragraphs 11 and 12 hereinafter.

### 10. DELIVERY

(a) Any indicated dates of delivery are approximate only, but NORD Gear will attempt to meet them whenever possible. (b) NORD Gear will not be liable for any penalty clauses contained in any specifications or order submitted unless agreed to in writing by an authorized officer of NORD Gear Corporation. (c) Unless otherwise agreed, delivery of the goods to any carrier shall constitute delivery to the Buyer, and thereafter the risk of loss or damage to the goods shall be upon the Buyer. (d) If the Buyer does not give delivery instructions to the Seller at least (10) days prior to the delivery date ex factory confirmed by the Seller, the Seller may deliver the goods to a carrier of its own choosing, at Buyer's cost and risk, or, at Seller's option, may store the goods on the pier or any warehouse, at Buyer's cost and risk. Any purchase price in such event becomes due and payable within ten (10) days of such storage.

### 11. PAYMENT OF PURCHASE PRICE

Time of payment is of the essence under the contract. Unless otherwise provided, terms of payment are 30 days net from the date of invoice with a 1% discount if paid within 10 days of date of invoice. Upon default in any of the terms of the contract, or failure to comply with any of the conditions thereof, or upon seizure of the property under execution or other legal process, or if the Buyer becomes bankrupt or insolvent, or any petition for reorganization or for a state court receivership is filed against Buyer, or if the Buyer makes any assignment for the benefit of its creditors or otherwise sells, encumbers or disposes of the goods, or if for any other reason the Seller should deem itself insecure, the full amount of the purchase price then remaining unpaid shall at once become due and payable at the option of the Seller.

### 12. BUYER'S DEFAULT

Upon the Buyer's default, the Seller may dispose of the merchandise in any manner that it deems fit and, if it desires to resell same, may do so at private or public sale, with or without notice, and with or without the property being at the place of sale, subject, however, to applicable laws. The Seller or its assigns shall have the right to bid at such sale and may become the purchaser of the property. The proceeds of the sale shall first be applied to the expenses incurred in retaking, repairing, storing and selling the goods, reasonable attorney's fees included, and then shall be applied to the payment of the balance due under the contract. Any surplus amount shall be paid to the Buyer. If a deficiency results after the resale, the Buyer agrees to pay such forthwith, together with reasonable attorney's fees, for the recovery of the goods incurred by the Seller. If upon the Buyer's default, the Seller elects not to resell any goods which it may repossess, then the cost of repossession, including reasonable attorney's fees, shall forthwith be due and payable from Buyer to Seller. Buyer agrees to pay all reasonable costs and reasonable attorney's fees incurred by Seller in enforcing Seller's rights against Buyer, including Seller's right to payment of the purchase price of the goods and Buyer's payment of all other amounts owing to Seller required under this Invoice and Conditions of Sale.

### 13. SECURITY INTEREST AND TITLE

In states and localities which are governed by the Uniform Commercial Code, this contract shall serve as security agreement, reserving in Seller a security interest until full payment of purchase price. The provisions of the Uniform Commercial Code regarding security interest shall have preference and apply if inconsistent with other terms of the conditions of sale. In states and localities where the Uniform Commercial Code does not apply, title to the goods shall remain in the Seller or its assigns until full payment of the purchase price. Buyer agrees to execute forthwith any and all documents in such a way and form as Seller may need for filing or recording the security interest under the Uniform Commercial Code with the proper registers or offices, or for filing or recording the conditional sales contract.

### 14. SALES AND USE TAX

Buyer agrees to bear and pay any sales or use tax in connection with the purchase herein, and to hold the Seller harmless from payment. At the option the Seller, Buyer shall give evidence of payment or of exemption certificate.

### 15. INSURANCE

The Buyer shall keep the goods insured against damage by fire, water or other casualty as required by Seller, with a company acceptable to Seller, with loss payable to Seller for the total purchase price until the Seller is fully paid. Seller, if it so elects, may place said insurance at Buyer's expense; Seller may cancel such insurance at any time and without notice and may receive the return premium, if any.

### 16. MODIFICATION BY SELLER

Any contract may be assigned or transferred by the Seller, or the time for the making of any payment due by Buyer may be extended by Seller without derogation of any of the rights of the Seller or its assigns. Waiver by any party of any default shall not be deemed a waiver of any subsequent default.

### 17. RETURNED GOODS

No goods will be accepted for return unless authorized in writing by Seller. In all cases, transportation and restocking charges will be borne by Buyer.

### 18. PACKING

The Buyer will be charged for export packaging or other special packing desired. Cost for cartage to ship or transfer express will be added to the invoice. No credit will be allowed if no packing is required.

### 19. CHANGES/CANCELLATION

NORD Gear will not accept changes in specifications to a confirmed order unless such changes are requested in writing and confirmed back in writing. In addition, the purchaser must to agree to any additional charges that may arise from the change. Placing orders on hold or cancellation of orders require Seller's written approval, and are subject to cancellation and/or restocking charges.

### 20. BUYER'S RESPONSIBILITY AS TO MAINTENANCE

Buyer shall use and shall require its employees and agents to use all safety devices and guards and shall maintain the same in proper working order. Buyer shall use and require its employees and agents to use safe operation procedures in operating the equipment and shall further obey and have its employees and agents obey safety instructions given by Seller. If Buyer fails to meet the obligations herein, Buyer agrees to defend, indemnify and save Seller harmless from any liability or obligation with regard to any personal injuries or property damages directly or indirectly connected with the operation of the equipment. Buyer further agrees to notify Seller promptly and in any event not later than ten (10) days after notice or knowledge of any accident or malfunction involving Seller's equipment which has caused personal injury or property damages and to cooperate fully with Seller in investigating and determining the causes of such accident and malfunction. In the event that Buyer fails to give such notice to Seller or to cooperate with Seller, Buyer shall be obligated to defend, indemnify and save Seller harmless from any such claims arising from such accident.

### 21. MISCELLANEOUS PROVISIONS

(a) If for any reason a provision of a contract is legally invalid, then in such event the rest of the contract shall remain in full force and effect, except that the parties shall try to replace such invalid provision closest to their original mutual intentions. (b) This Invoice and these Conditions of Sale constitute the entire agreement between the parties regarding the subject matter hereof and supercedes all prior agreements, understandings and statements, whether oral or written, regarding such subject matter. No modification to, change in or departure from, the provisions of this Invoice and Conditions of Sale shall be valid or binding on Seller, unless approved in writing by Seller. No course of dealing or usage of trade shall be applicable unless expressly incorporated into this Invoice and Conditions of Sale. Any amendments to any contract or contracts between the parties shall be valid only upon the written consent of both parties.

### 22. NON ASSIGNMENT BY BUYER

Contract or contracts may not be assigned by the Buyer without prior written consent of the Seller.

### 23. APPLICABLE LAW AND VENUE

All contracts and their interpretation are governed by the applicable, substantive laws of the State of Wisconsin. Any litigation brought by the Buyer regarding this Invoice or goods purchased hereunder may only be brought in the Circuit Court for Dane County, Wisconsin.

**NORD Gear Corporation**

Toll Free in the United States: 888.314.6673

09.24.14

Nord Gear Company Terms 09/14

[www.nord.com/docs](http://www.nord.com/docs)

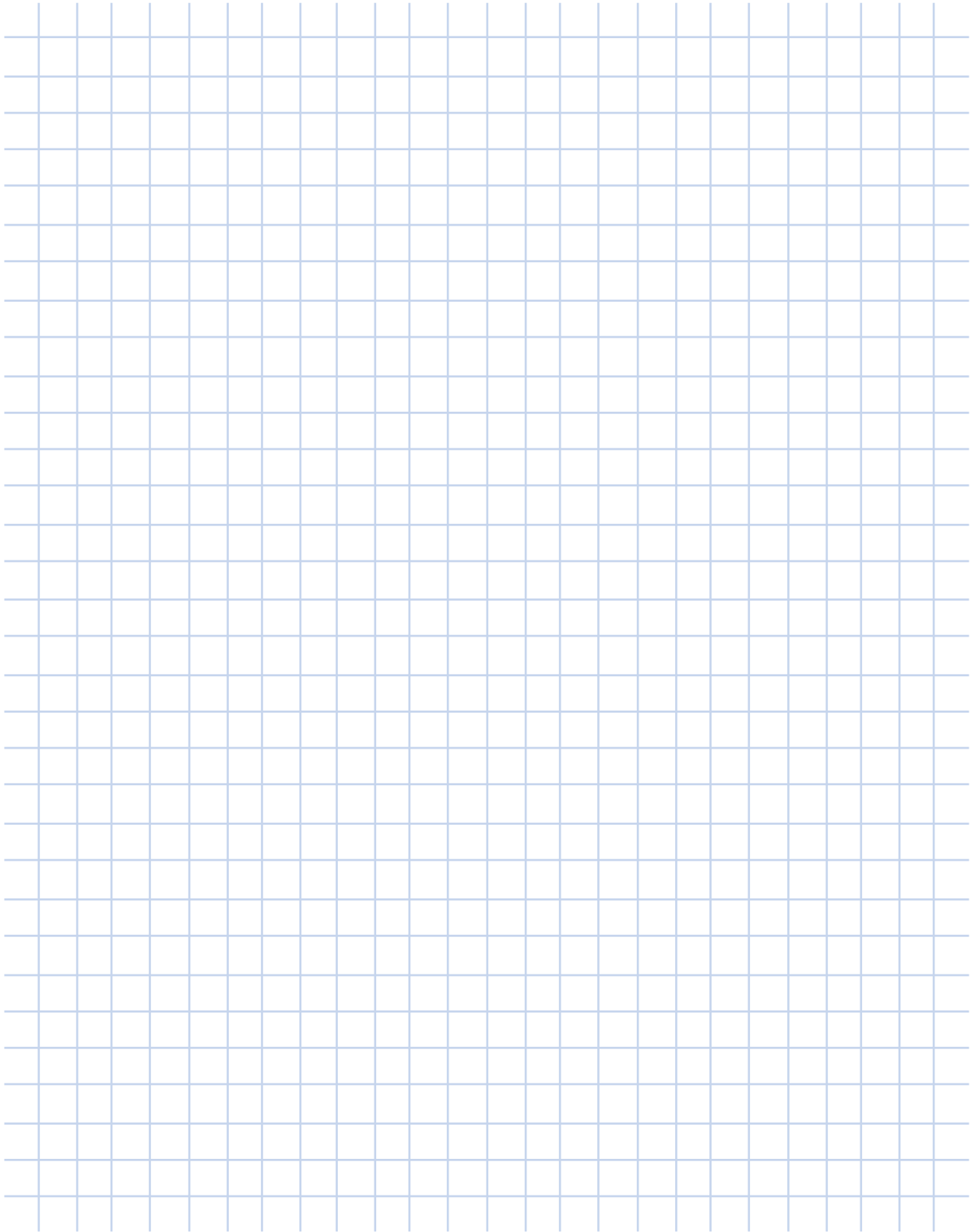

# Product Overview

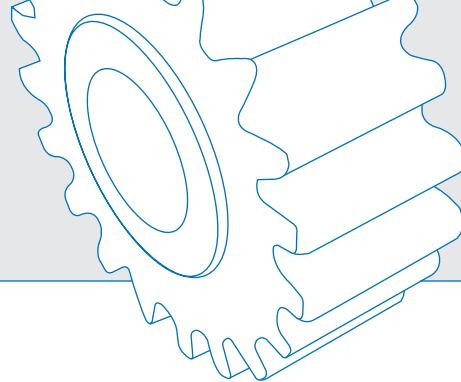

## UNICASE™ SPEED REDUCERS

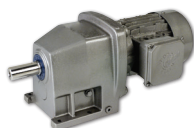

### HELICAL IN-LINE

- Foot or Flange Mount
- Torque up to 205,000 lb-in
- Gear ratios – 1.82:1 to over 300,000:1



### NORDBLOC®.1 HELICAL IN-LINE

- Foot or Flange Mount
- Torque up to 26,550 lb-in
- Gear ratios – 1.88:1 to over 370:1



### PARALLEL HELICAL CLINCHER™

- Shaft, Flange or Foot Mount
- Torque up to 797,000 lb-in
- Gear ratios – 4.26:1 to over 300,000:1

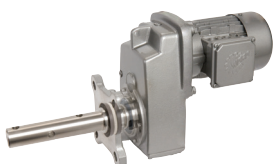

### SCP SCREW CONVEYOR PACKAGE

- Shaft, or Flange Mount
- Torque up to 53,100 lb-in
- Gear ratios – 4.32:1 to over 1500:1



### RIGHT ANGLE

#### HELICAL-BEVEL 2-STAGE

- Foot, Flange or Shaft Mount
- Torque up to 5,840 lb-in
- Gear ratios – 4.1:1 to 70:1

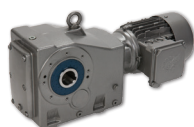

### RIGHT ANGLE HELICAL-BEVEL

- Foot, Flange or Shaft Mount
- Torque up to 283,000 lb-in
- Gear ratios – 8.04:1 to over 300,000:1



### RIGHT ANGLE HELICAL-WORM

- Foot, Flange or Shaft Mount
- Torque up to 27,585 lb-in
- Gear ratios – 4.40:1 to over 300,000:1

## HIGH PERFORMANCE MOTORS & BRAKEMOTORS



### INVERTER/VECTOR DUTY

- Standard or Energy Efficient
- Integral, NEMA or Metric IEC
- 1/6 to 250 hp

## UNICASE™ SPEED REDUCERS

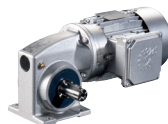

### MINICASE™ RIGHT ANGLE WORM

- Foot, Flange or Shaft Mount
- Torque up to 3,540 lb-in
- Gear ratios – 5:1 to 500:1

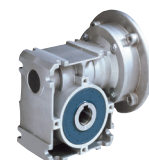

### FLEXBLOC™ WORM

- Modular bolt-on options
- Torque up to 4,683 lb-in
- Gear ratios – 5:1 to 3,000:1

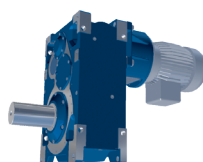

### MAXXDRIVE™ LARGE INDUSTRIAL GEAR UNITS PARALLEL HELICAL

- Modular bolt-on options
- Torque up to 2,027,000 lb-in
- Gear ratios – 5:1 to 1,600:1

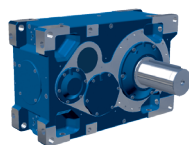

### MAXXDRIVE™ LARGE INDUSTRIAL GEAR UNITS HELICAL-BEVEL

- Modular bolt-on options
- Torque up to 2,027,000 lb-in
- Gear ratios – 5:1 to 1,600:1

## NORDAC AC VECTOR DRIVES



### SK180E FAMILY

- Distributed, simple speed control
- 380-480V, 3-phase to 3.0 hp
- 200-240V, 3-phase to 1.5 hp
- 200-240V, 1-phase to 1.5 hp
- 100-120V, 1-phase to 0.75 hp



### SK200E FAMILY

- Distributed, high performance
- 380-480V, 3-phase to 30 hp
- 200-240V, 3-phase to 15 hp
- 200-240V, 1-phase to 1.5 hp
- 100-120V, 1-phase to 1 hp



### SK500E FAMILY

- Compact, cabinet mount, high performance
- 380-480V, 3-phase, to 125 hp
- 200-240V, 3-phase, to 25 hp
- 200-240V, 1-phase, to 3 hp
- 100-120V, 1-phase, to 1.5 hp



**DRIVESYSTEMS**

**[www.nord.com](http://www.nord.com)**

**WEST**

Corona, CA (Los Angeles)  
Phone: 951.393.6565

**MIDWEST**

Waukegan, WI (Madison)  
Phone: 608.849.7300

**EAST**

Charlotte, NC  
Phone: 980.215.7575

**NORD Gear Corporation**

National Customer Service Toll-Free: 888.314.6673  
[info.us@nord.com](mailto:info.us@nord.com)

**NORD Gear Limited**

Toll-Free in Canada: 800.668.4378  
[info.ca@nord.com](mailto:info.ca@nord.com)

**CANADA**

Brampton, ON (Toronto)  
Phone: 905.796.3606