

INTELLIGENT DRIVESYSTEMS, WORLDWIDE SERVICES

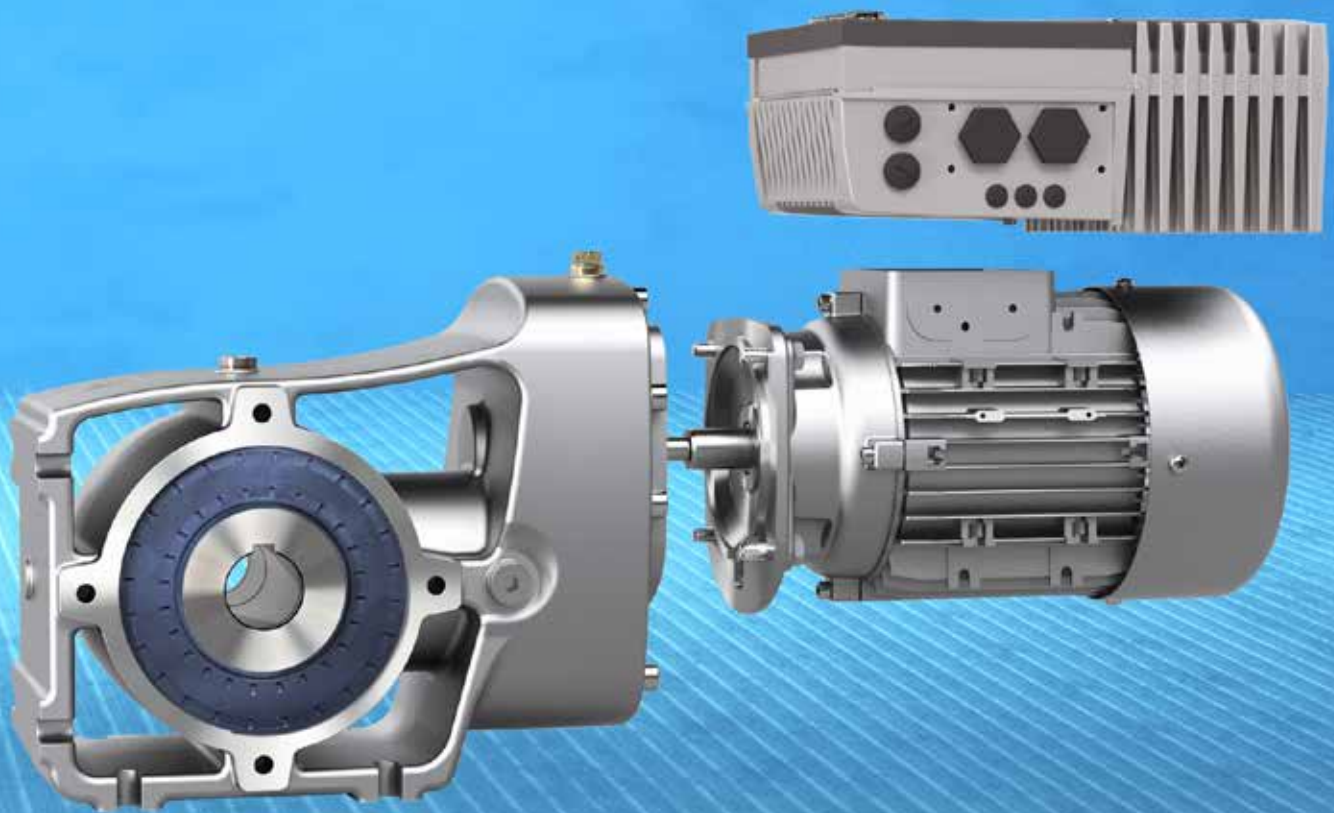

**DRIVE SOLUTIONS FOR
SERVO APPLICATIONS**



SERVO APPLICATIONS

DYNAMIC POSITIONING



High bay warehouse at the
NORD logistics centre in Bargteheide
near Hamburg, Germany



NORD DRIVESYSTEMS Group

Headquarters and technology centre in Bargteheide near Hamburg



Innovative drive solutions for more than 100 branches of industry

Mechanical products

Gear units



Electrical products

Motors



Electronic products

Frequency inverters and motor starters



7 production locations with cutting-edge technology produce gear units, motors, frequency inverters etc. for complete drive systems from a single source.



Gear unit production



Motor production



Inverter production

Subsidiaries and sales partners in 98 countries on 5 continents provide local stocks, assembly centres, technical support and customer service.



The map shown above is for information only and does not claim to be created for or applicable to any legal purpose. For this reason, we do not assume any liability for legality, correctness and completeness.

More than 4,000 employees throughout the world create customised solutions.



DRIVE SOLUTIONS FOR SERVO APPLICATIONS

A servo drive unit is a drive unit with electronic control of the position, speed or torque, with exceedingly high demands for dynamics, adjustment range and/or precise movement.

NORD DRIVESYSTEMS supplies drive solutions which consist of:

- Motors (ASM/PMSM)*
- Gear units
- Drive electronics
- Accessories (cables, plug connectors, encoders)

for a wide range of servo applications.

Almost all components are from the NORD product range and therefore provide great advantages with regard to costs and flexibility.

Applications such as positioning, synchronous operating or winding can normally be realised from the NORD product range.

If you use servo drives, please enquire about NORD solutions.

* ASM = Asynchronous motor
PMSM = Permanent magnet synchronous motor

DRIVE UNITS for positioning applications

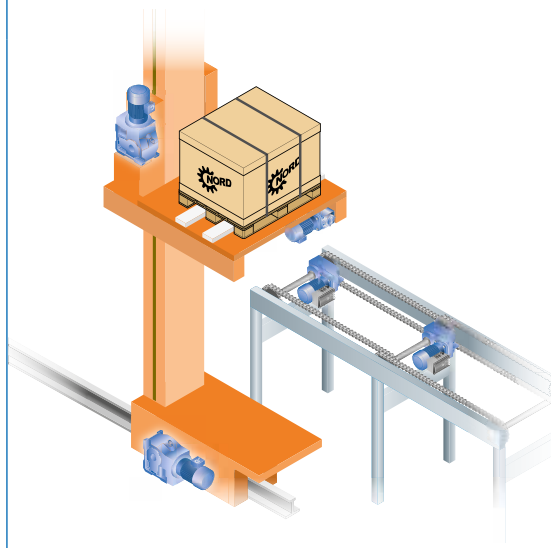

Fields of application

- Storage and retrieval devices
- Lifting platforms, lifting systems
- Overhead and portal cranes
- Stacking and palletising systems
- Automatic door systems

DRIVE UNITS for synchronous operation / axis coordination

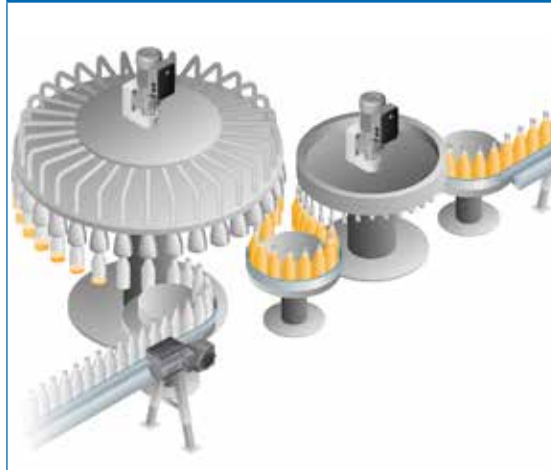

- Lifting stations
- Bottling plants
- Rolling, drawing and stretching
- Conveying and alignment of endless materials
- Cross cutters
- Flying saw
- Linear XYZ portal systems

DRIVE UNITS for winding applications

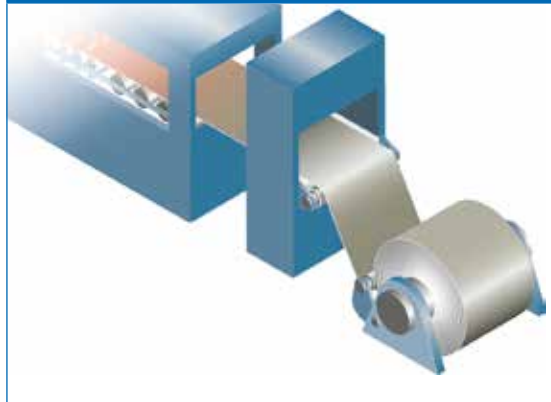

- Winders and unwinders for various materials
- Coordinated cutting blade

Advantages	Components
<ul style="list-style-type: none"> ✓ Flexible → Multi-compatible ASM technology from the modular system ✓ Precise speed control ✓ Precise positioning function / simple configuration ✓ Absolute, relative and remaining distance positioning ✓ Position setpoints can be saved in the device or via the BUS ✓ Jerk-free movement → S-ramp function ✓ Simple → Teach in function for positioning evaluation ✓ Simple → Integrated freely programmable sequence control (logic) ✓ Can be installed in the field → The electronic drive technology is integrated into the motor ✓ Flexible → Uniform interfaces and parameter structures for all drive types ✓ Free configuration of the geared motor ✓ Plug-and-Play with power and control signal plug connectors and switches 	<ul style="list-style-type: none"> ■ Geared motors from the NORD modular range ■ SK 530E inverter and above (control cabinet) ■ And/or decentralised SK 200E inverter ■ Incremental / absolute encoders ■ PLC functionality ■ All BUS systems
<ul style="list-style-type: none"> ✓ Synchronous torque ✓ Synchronous speed ✓ Synchronous positioning → Using integrated positioning functionality ✓ Electronic gear units ✓ Simple → Standard function modules ✓ Large radial and axial forces ✓ Speed feedback with incremental encoders ✓ Master-Slave communication can be implemented via the integrated system bus →  ... 	<ul style="list-style-type: none"> ■ Geared motors from the NORD modular range ■ SK 520E inverter and above (control cabinet) ■ And/or decentralised SK 200E inverter ■ Incremental / absolute encoders ■ PLC functionality ■ All BUS systems
<ul style="list-style-type: none"> ✓ Fully integrated → Winding computer via integrated PLC functionality ✓ Save space and stay flexible → High power decentralised technology up to 22 kW; high dynamic performance in minimum space, mounted on or near to the motor ✓ Simple operation → Automatic coordination of the cutting blade ✓ All inclusive → PI/PID process control for compensator regulation ✓ Safe and precise → Precision torque control ✓ Efficient → DC coupling or integrated brake chopper ✓ System solutions → Perfect system concepts thanks to optimised gear unit and motor design 	<ul style="list-style-type: none"> ■ Geared motors from the NORD modular range ■ SK 520E inverter and above (control cabinet) ■ And/or decentralised SK 200E inverter ■ Incremental encoders ■ Positioning for coil changing ■ PLC functionality ■ All BUS systems

DRIVE DESIGN IN DIALOGUE

Extensive knowledge of the application and expert knowledge in the field of drive technology form the basis for an optimum and individual drive solution for your application.

This process requires an intensive dialogue between you and NORD DRIVESYSTEMS. With its design and advisory expertise, NORD DRIVESYSTEMS ensures maximum added value throughout this decisive process.

From the transfer of know-how to the optimum technical solution, you will see added value at each individual stage.

Together with the customer, NORD DRIVESYSTEMS works out solutions for dynamic positioning tasks. In general, the specific details of the drive system, the conditions of use and integration into the system are formulated and the load-specific data are recorded. Drive design programs provide support for the calculation of static and dynamic load situations and assist in the selection of a suitable drive unit.

Careful consideration of the inertia of the system is essential for dynamic movement processes. For drive project planning, NORD DRIVESYSTEMS utilises its many years of experience with drive units.

The calculated load characteristics are matched to the characteristics of the drive unit for selection of a suitable drive unit.



Translatorisches Trägheitsmoment:

$$J_T = m_T * \left(\frac{h}{2 * \pi} \right)^2 = \frac{h * i}{\pi} * \frac{F_L}{2000} [Nm]$$

Rotatorisches Trägheitsmoment:

$$J_R = \frac{m}{2} * r^2 = \frac{\pi}{2} * l * \rho * r^4$$

(Vollzylinder)

$$J_R = \frac{m}{2} * (r_o^2 * r_i^2) = \frac{\pi}{2} * l * \rho * (r_o^4 - r_i^4)$$

(Hohlzylinder)

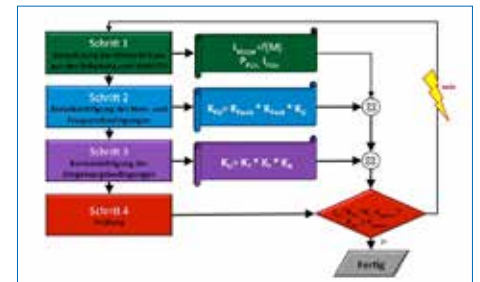

The NORD range of geared motors provides a comprehensive and flexible modular system with complex degrees of freedom, which enable the selection of the ideal drive unit with regard to dynamics, size, weight or price.

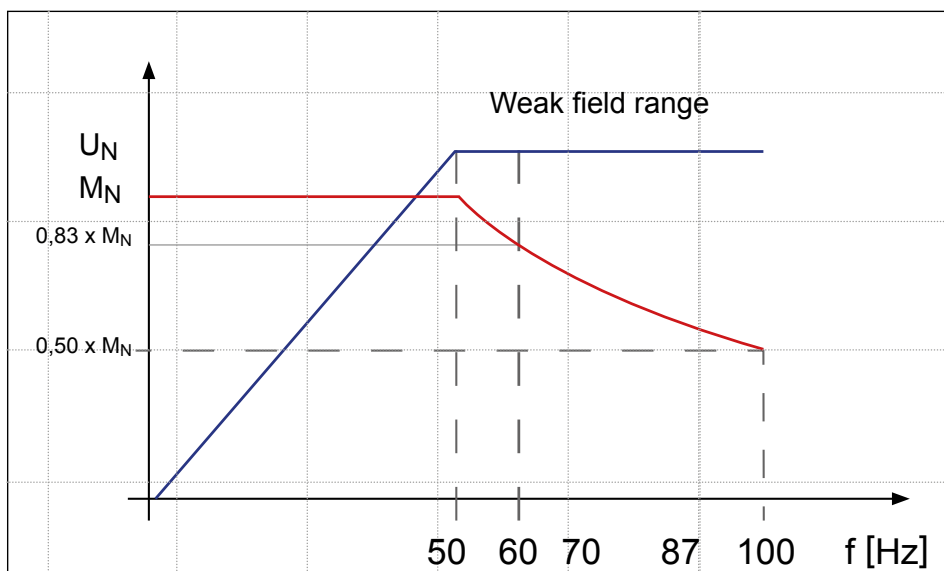

For commissioning and drive optimisation, NORD DRIVESYSTEMS provides an attractive analysis tool and qualified specialists, who support the project from the very start up to the series production stage.

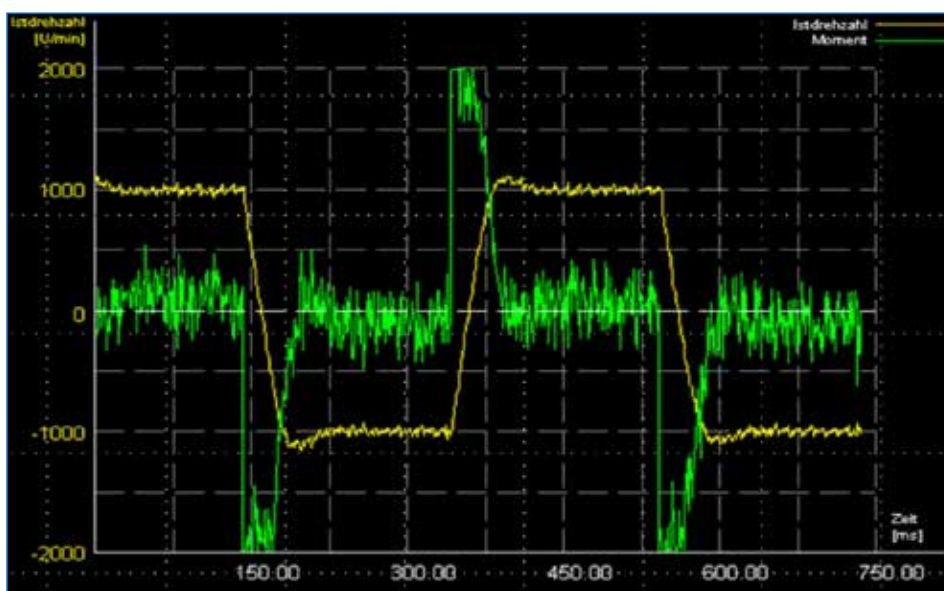

Excerpt from the power and speed tables 2.20 kW
(Catalogue G4010)

P_1 [kW]	n_2 [min ⁻¹]	M_{2b} [Nm]	f_B	i_{ges}	F_R	F_A	Type	kg
2.20	7.4 – 37	572	1.1	39.32	8.9	25.0	SK 92772.1 / 100LH/4 / SK 200E – 221 – 340 -A (-C) SK 92772.1 / 100LP/4 / SK 200E – 221 – 340 -A (-C) SK 93772.1 / 100LH/4 / SK 200E – 221 – 340 -A (-C) SK 93772.1 / 100LP/4 / SK 200E – 221 – 340 -A (-C)	67
	8.2 – 41	509	1.3	35.04	9.3	25.0		
	9.1 – 45	463	1.4	31.85	9.5	25.0		
	10 – 51	413	1.5	28.38	9.7	25.0		
	11 – 57	368	1.7	25.34	9.9	25.0		
	13 – 64	328	2.0	22.59	10.0	25.0		
	14 – 68	307	2.0	21.14	10.0	25.0		
	15 – 75	270	2.3	10.17	10.1	25.0		
	15 – 77	274	2.3	18.84	10.1	25.0		
	17 – 85	218	2.6	17.08	10.2	25.0		
	10 – 94	224	2.8	15.42	10.2	25.0		
	21 – 105	200	3.0	13.79	10.3	25.0		
23 – 116	182	3.3	12.50	10.3	25.0			

APPLICATION SOLUTION

PALLETISING MACHINE

The application

Decentralised NORD drive units consisting of geared motors and motor-mounted frequency inverters control the complex movement sequences of the centring unit and the manipulator of the high performance palletising machines.

The customer

The Dutch engineering company SYMACH Palletizers B.V. develops and manufactures palletisers and is a technological leader in this sector. SYMACH was created from the company De Feijter as a result of a buy-out. Customers on several continents include suppliers of animal feeds, grass seed, carrots, potatoes, onions, bakery products and cereals.

The machine and its function

Palletising machines form the basis for efficient production and distribution processes. The high performance palletising machines from the Dutch engineering company SYMACH can position each product individually. Sacks, boxes or crates are supplied via a conveyor belt, aligned with a centring unit and gently placed in their precise positions with a specially designed manipulator.

Rapid stack processing

Various stacking patterns can be programmed and sacks can be stacked with a maximum speed of between 15 and 36 sacks per minute depending on the type of machine. During the stacking process the loaded pallet is lowered, until the defined loading height has been reached. After this it is transported to a wrapping machine using a roller conveyor.

No more bulky servo control cabinets

For many years, all SYMACH machines were equipped with centralised drive control units. The control cabinets for the servo electronics on the top of the machine not only caused high costs, but also created space problems: SYMACH palletising machines are so high that they are equipped with steps. For maintenance work via this route, large servo control cabinets had been an obstruction.

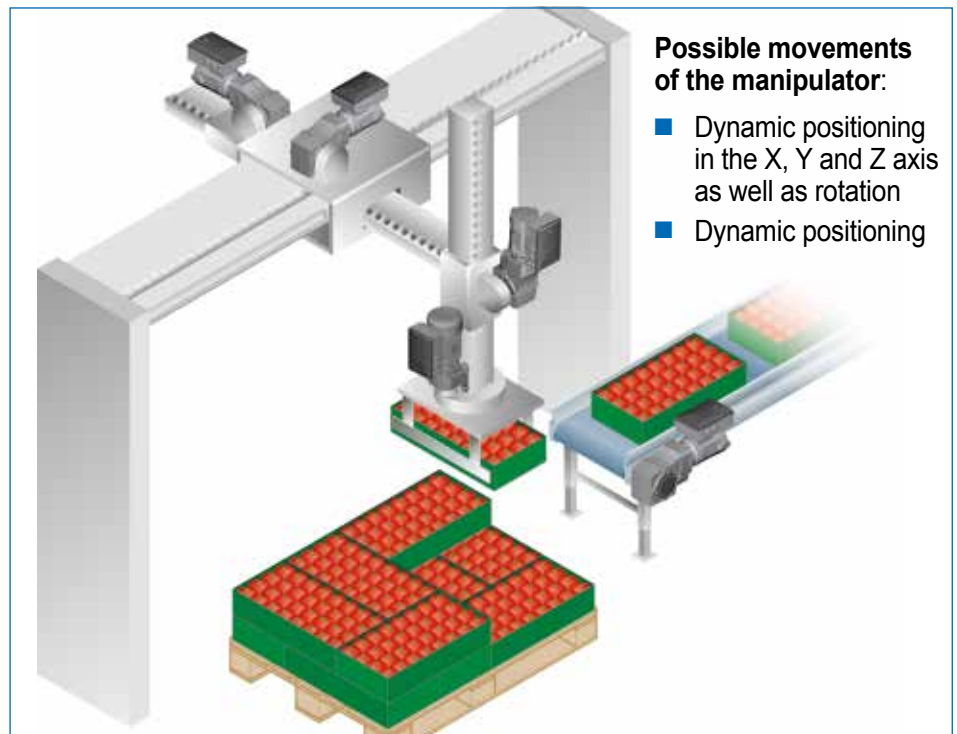

Complete drive units

In the latest generation of SYMACH palletising machines, instead of servo control units, integrated drive units consisting of a geared motor and a frequency inverter provide the necessary dynamic performance.

High precision and dynamics

NORD DRIVESYSTEMS supplies SYMACH with frequency inverters, ready-wired motors, speed sensors, braking resistors and motor holding brakes and therefore considerably reduces the installation effort in comparison with the previous solution. The NORD POSICON frequency inverter function enables highly dynamic positioning with a maximum precision of approx. 1/100 motor revolution.

Safety and intelligent communication

SYMACH uses SK 215E frequency inverters with the additional "Safe Stop" function, which ensures the necessary protection of personnel at all times. Detection of the orientation/position is carried out by the compact, wear-free and cost-effective MG encoder system. Sensors and actuators are simply connected to the I/Os of the inverter, which is directly installed in the machine. This exchanges data with the higher level control system via CANopen communication.



“Engineers tend to be wary of changes. However, we received excellent advice from NORD DRIVESYSTEMS for the re-engineering process for our palletising machines. This was just as decisive as the quality of the products.”

Sacha Bakker, Managing Partner, SYMACH Palletizers

Advantages of asynchronous motors:

- Cheap and widely available
- Maintenance-friendly and easy to replace
- Can be combined with various types of gear unit

The NORD solution for SYMACH:

- High dynamics, high safety
- Lower production costs
- Greatly simplified wiring
- Better access to the machine
- More compact machine design

Decentralised drive units consisting of a gear unit, motor and electronics replace centralised servo technology and enable highest dynamic levels for palletising.

FLEXIBLE COMBINATIONS FOR SERVO APPLICATIONS



GEAR UNITS



Robust gear units in one-piece UNICASE housing can cater for any load.

- Comprehensive modular control system
- High overload capacity
- Low gear backlash
- High power density
- Long service life

MOTORS



Powerful motors keep the drive systems moving in all situations.

- High dynamic motors
- High overload capacity
- Also as IE4 motor with synchronous technology
- Extensive range of motor options (e.g. external fan, absolute encoder, incremental encoder, brake motors)

FREQUENCY INVERTERS



Intelligent drive electronics provide exactly the control facilities you need.

- Scalable scope of functions
- Wide power range
- Drive inverter for dynamic applications
- High overload capacity
- Short response times
- Sensorless current vector control
- Wide range of field bus interfaces for easy system integration

RAPID INSTALLATION TOOLS/BUS SYSTEMS



Extensive communication options enable access to the drive unit from all levels, providing a wide range of adjustments.

- All common bus systems
- Quick and simple commissioning with plug-in control unit or with NORDCON software
- Convenient hand-held unit for local control

LOCAL CONTROL



Switches and buttons are located directly on the drive units (optional) and enable direct starting, stopping or mode changes.

- Mains switch
- Selector switch for local or remote control
- Start/Stop and Forward/Reverse switch

QUICK CONNECTIONS



All interfaces are designed for simple handling, so that drives can be very conveniently configured and installed.

- Simple Plug-and-Play with all common quick connection plugs
- Supply cable and motor outlet
- Plug-in sensors and encoders
- Pre-assembled cables



APPLICATION EXAMPLE

SYNCHRONISED POSITIONING

For synchronous position operation of two or more NORD drive units, coupling of the drive inverters is via the system bus. The system bus is a CANopen-based bus protocol for which the connection of the required interfaces is already integrated into NORD drive inverters (integrated networking).

In addition, the NORD inverters require the integrated POSICON positioning function (Standard in all SK 200E inverters and in SK 530E/535E). The master continuously communicates the actual position to the slave inverter as a setpoint value. For dynamic pre-control, in addition the actual speed of the master is communicated to the slave drive as a pre-control setpoint speed.

Position detection can be performed with an incremental encoder (referencing required) or with an absolute encoder. CANopen absolute encoders are read via the system bus interface and can be easily integrated in the system bus network. Path-optimised movement, remaining distance positioning, flying saw, as well as slip error and bus monitoring provide the necessary range of functions and reliability of the application.

Master/Slave operation

- Control of one or more slave inverters by a master inverter
- Communication via USS or CANopen with control word and setpoint values
- Speed or synchronised positioning possible according to performance level

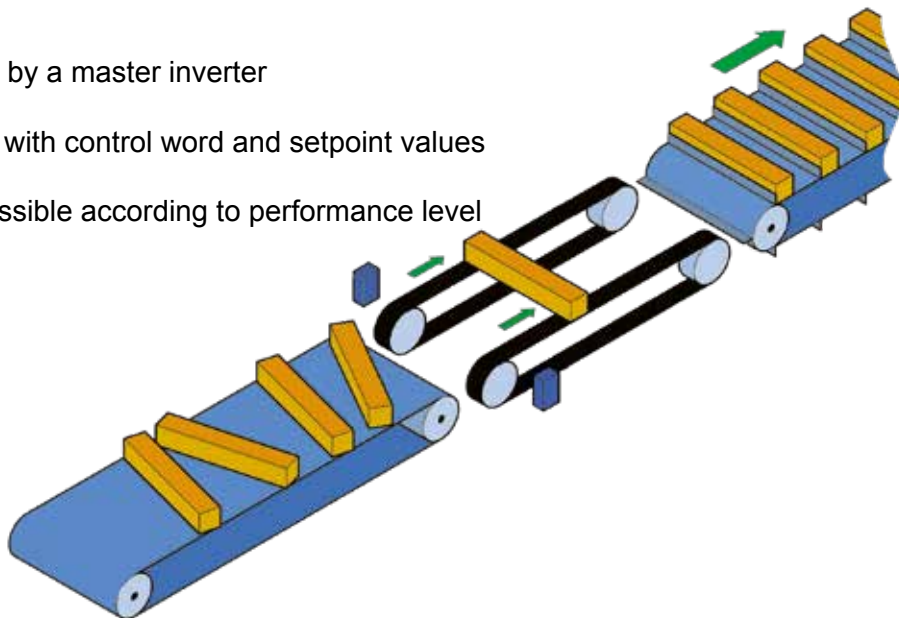

SETPOINT PROCESSING

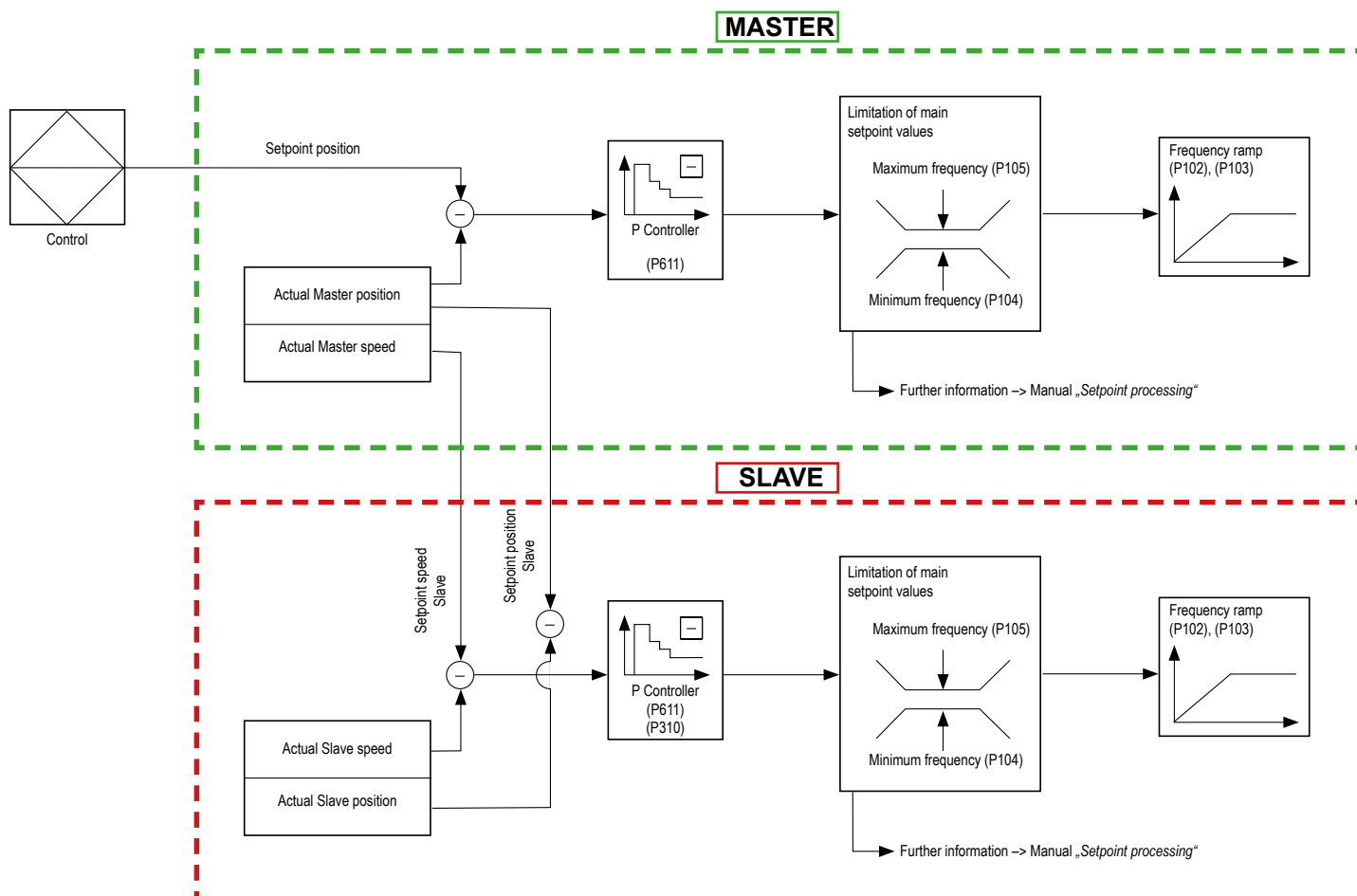

APPLICATION EXAMPLE

SYNCHRONISED POSITIONING

The most suitable solution for closed control loops in which dimensions such as temperature, pressure, flow rate or levels are to be controlled, is the use of PI controllers.

The task of a drive using this method is to automatically adjust itself to a setpoint value (a guide value) and to independently compensate fluctuations due to disturbances.

This application note examines 2 typical variants of the application.

- Controller with a fixed setpoint
- Controller with a variable setpoint

The details on the general requirements and optimisation apply to both cases. This description is based on the SK 500E. However, if the different designations of the connection terminals or parameter numbers are taken into account it can also be applied to other NORD frequency inverters.

[Outline conditions → Page 15](#)

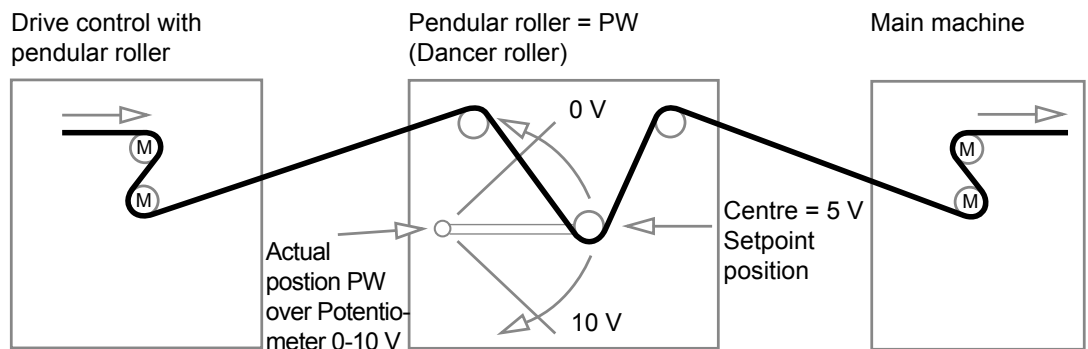

SETPOINT PROCESSING

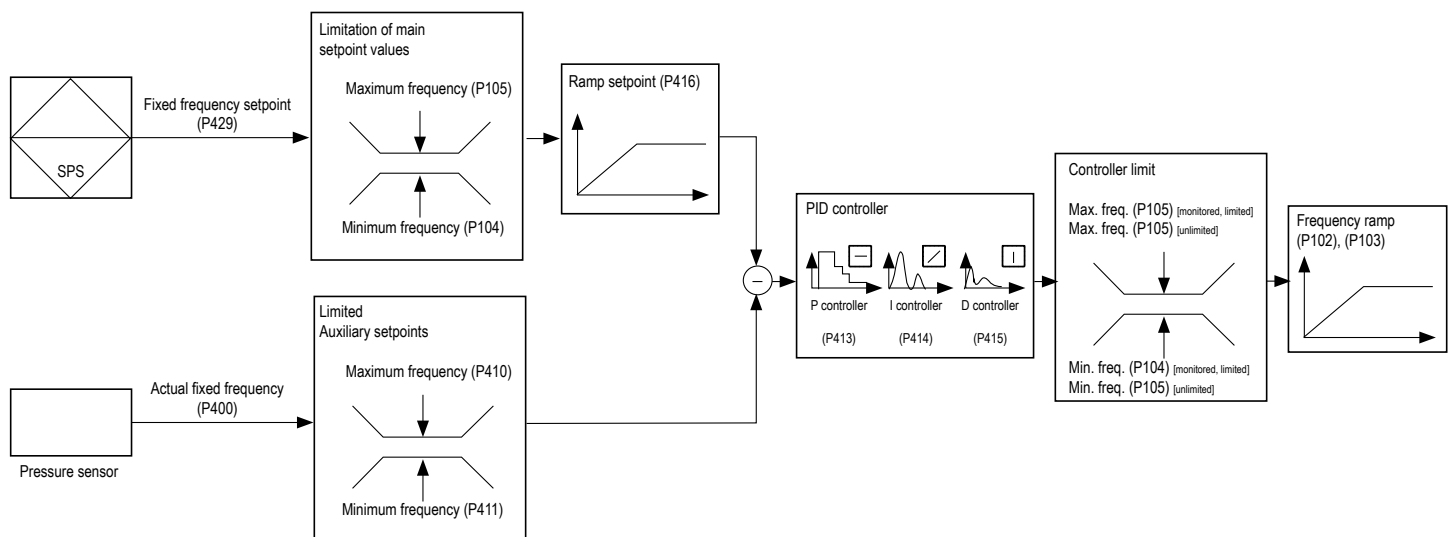

Outline conditions: Clarification of the outline conditions specific to the application
 The values used for this application example are printed in **bold** in the table.

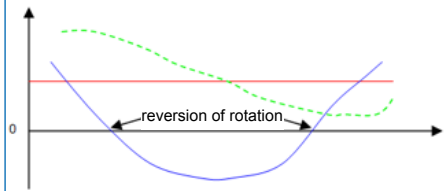
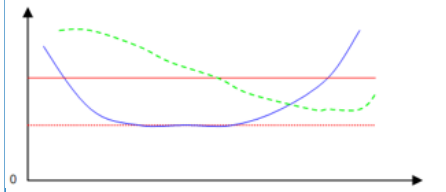
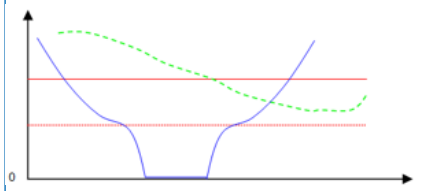
Description	Detail	Parameter	Example
Operating range of the drive	Min. frequency	P104	10 Hz
	Max. frequency	P105	50 Hz
Sensor data – actual value detector	Type Output signal		4 ... 20 mA
Operating range of sensor	Actual value for min. frequency 0% adjustment	P402	1.6 V (corresponds to 8 mA)
	Actual value for max. frequency 100% adjustment	P403	3.2 V (corresponds to 16 mA)
Effective direction of the drive vs. sensor signal	The sensor signal increases as the speed increases	P402 = min. operating value and P403 = max. operating value	P402 = 1.6 V P403 = 3.2 V
	Note: If the drive acts in the opposite direction, the parameters must also be set in the opposite direction		
	The sensor signal reduces as the speed increases	Invert P402 and P403: P402 = max. operating value and P403 = min. operating value	P402 = 3.2 V P403 = 1.6 V
Operating range of the system (Parameterisation of the analog inputs)	Failure of actual value (wire break protection)	P401	(0) = "Limited to 0–10 V" (the drive unit operates with (P104)) (2) = "Monitored 0–10 V" (the drive unit switches off)
	PI – (controller) behaviour: Permissible behaviour of the drive if the actual value is greater than the setpoint value	P400	(3) = Change of direction possible  <p>Example: (P400), function "Actual frequency PI(D)"</p> (8) = Drive operates at least with (P104)  <p>Example: (P400), function "Actual frequency PI(D) limited"</p> (9) = Drive switches off  <p>Example: (P400), function "Actual frequency PI(D) monitored"</p> <div style="border: 1px solid black; padding: 5px; margin-top: 10px;"> <ul style="list-style-type: none"> --- Actual value (pressure sensor) --- Speed, frequency inverter / motor --- Setpoint (e.g. P429) --- Minimum frequency (P104) </div>

EXCERPT FROM SK 200E PRODUCT CATALOGUE

SK 200E – Universal frequency inverter for decentralised applications

Frequency inverters are now essential components for electrical drive technology. They are now used for a wide range of applications in almost all fields of application.

Universal

The SK 200E, the all-rounder among decentralised frequency inverters, has established itself in almost all areas of engineering and industry. For this, not only the wide range of available powers (up to

22 kW – by no means something which can be taken for granted in decentralised drive technology) but also the enormous range of functions and the flexibility due to a comprehensive range of accessories play an important role.

Economical

The series has been structured with various function levels in order to take efficiency and customers' application-specific requirements into account. In addition, we have arranged the series into two equipment groups, which optimally cater for typical customer applications for conveyors, pumps and fans.

Energy-saving

Even, or especially for applications in which a frequency inverter is not strictly necessary from a technical point of view (constant speed with 50 Hz), the SK 200E beats every unregulated drive unit with its enormous energy-saving characteristics, especially in partial load operation.

Equipment of the SK 200E



Standard

- Open loop and closed loop current vector control
- High overload reserves
- Rapid, internal signal processing and short response time
- 4 switchable parameter sets for flexible use of parameter settings
- Wide range of drive functions, such as S ramp acceleration and deceleration, quick stop function, evacuation runs, process controller, end point

monitoring, torque limitation and load monitoring

- POSICON for relative and absolute positioning
- Evaluation of incremental encoder signals and CANopen absolute encoders
- Automatic motor identification

Optional

- Interfaces for 8 field bus systems (at present)
- Various control options (Switch, potentiometer or control and parameterisation units)
- Versions with functional safety ("Safe Stop")
- IO Modules for additional analog and digital signal outputs
- System plug connectors for the power connections of mains and motor cables (industrial plug connectors) as well as for

control and signal cables (M12 plug connectors)

- ATEX Versions for operation in Zone 22 – 3D





Precision combined with logic POSION and PLC

POSION

Frequency inverters with integrated POSICON functionality are able to determine the actual position of the drive unit via appropriate interfaces. Incremental encoder inputs (TTL/HTL) or absolute encoders are available as interfaces via CANopen (from SK 540E and above, sin/cos wave encoders, SSI, BISS, EnDat 2.1 and Hyperface) are also available. In addition to conventional point-to-point positioning (absolute positioning), POSICON also provides the facility for relative or additive positioning of endless axes ("Motion Control") as well as various technology functions (rotating platform "with travel optimisation", synchronous operation and flying saw).

By means of the standard POSICON position memory and features such as "teach in",

"reference point", "reset position", "offset position", "remaining distance positioning" and "S-ramp", the frequency inverter is able to perform complete, independent positioning control. The tasks for the external control are therefore reduced to the starting pulse and communication of the target position (via digital I/O or at the field bus level). The frequency inverter can even undertake monitoring of the positioning process and reporting of the operating status.

Applications

- Lifting gear/Shelf storage and retrieval devices with approach to precise positions
- Running gear of material conveyors/Portal cranes with synchronous function of all driven axes
- Rotating table functions for tool magazines on machines
- Flying saw: Coupling and parallel movement of a saw relative to a moving object

PLC

In most cases the frequency inverter is controlled by means of an overriding PLC. However, the use of an external PLC requires additional space, installation effort and costs in order to implement communication between the PLC and the participants (e.g. frequency inverters). In many systems with relatively simple drive functions, the expense required soon becomes unacceptable.

This is where the SK 540E / SK 545E come into their own. Their integrated IL-based PLC functionality (based on IEC 61131-3) is specially designed for drive functions. With a computational performance of approx. 200 IL commands per ms and a total of 1,280 commands in the program, this control unit is able to undertake many tasks in the field of the frequency inverter. Inverter inputs or information from a connected field bus can be monitored, evaluated and further processed into appropriate setpoint values for the frequency inverter. Visualisation of system statuses and the input of special customer parameters is possible by means of optional equipment (ParameterBox, NORDCON software).

Applications

- Intelligent flow control for conveying systems with detection and response to load-related events
- Logic control function for load lifting application

APPLICATION PLANNING FORM

1. Technology functions

- | | | | |
|--|--|---|--|
| <input type="checkbox"/> Control | <input type="checkbox"/> Speed | <input type="checkbox"/> Precision requirement | = _____ |
| | <input type="checkbox"/> Torque | <input type="checkbox"/> Precision requirement | = _____ |
| | <input type="checkbox"/> Position | <input type="checkbox"/> Precision requirement | = _____ |
| <input type="checkbox"/> Synchronous operation | <input type="checkbox"/> Speed | <input type="checkbox"/> Electronic gear unit i | = _____ |
| | <input type="checkbox"/> Torque | | |
| | <input type="checkbox"/> Position | | |
| <input type="checkbox"/> Positioning | <input type="checkbox"/> Absolut | <input type="checkbox"/> Reference run possible | <input type="checkbox"/> yes / <input type="checkbox"/> no |
| | <input type="checkbox"/> Relative | | |
| | <input type="checkbox"/> Residual path | | |
| <input type="checkbox"/> PI controller: _____ | | <input type="checkbox"/> PLC function: _____ | |

2. Control unit environment

- | | | |
|---|--|---|
| <input type="checkbox"/> BUS connection: _____ | <input type="checkbox"/> Sensors: _____ | <input type="checkbox"/> Visualisation: _____ |
| <input type="checkbox"/> Local control | <input type="checkbox"/> Auto/Local switch | |
| | <input type="checkbox"/> Fwd/O/Rev switch | |
| | <input type="checkbox"/> _____ | |
| <input type="checkbox"/> Setpoint specification | <input type="checkbox"/> BUS | <input type="checkbox"/> Digital inputs |
| | <input type="checkbox"/> 0...10V | <input type="checkbox"/> _____ |
| | <input type="checkbox"/> 4...20 mA | |
| <input type="checkbox"/> I/O configuration | <input type="checkbox"/> Digital inputs _____ | <input type="checkbox"/> Analog inputs _____ |
| | <input type="checkbox"/> Digital outputs _____ | <input type="checkbox"/> Analog outputs _____ |

3. Description of application / Diagram

APPLICATION PLANNING FORM

4. System data

- | | |
|--|---|
| <input type="checkbox"/> Net mass: _____ kg | <input type="checkbox"/> Stopping precision (+): _____ |
| <input type="checkbox"/> Load weight: _____ kg | <input type="checkbox"/> Ratio of primary reduction gearing: _____ kgm ² |
| <input type="checkbox"/> Movement path: _____ mm | <input type="checkbox"/> Inertia of primary reduction gearing: _____ |
| <input type="checkbox"/> Time for movement: _____ s | <input type="checkbox"/> Efficiency of system: _____ |
| <input type="checkbox"/> Standstill time: _____ s | <input type="checkbox"/> Installation orientation of drive unit: _____ |
| <input type="checkbox"/> Total cycle time: _____ s | <input type="checkbox"/> Radial force of drive shafts: _____ N |
| <input type="checkbox"/> Max. permissible acceleration: _____ m/s ² | <input type="checkbox"/> Axial force of drive shafts: _____ N |
| <input type="checkbox"/> Max. permissible deceleration: _____ m/s ² | <input type="checkbox"/> Holding brake: _____ Nm |

5. Drive data

- | | | |
|---|---|--|
| <input type="checkbox"/> Asynchronous motor | <input type="checkbox"/> Direct drive | <input type="checkbox"/> Helical gear units |
| <input type="checkbox"/> Synchronous motor | <input type="checkbox"/> Geared motor | <input type="checkbox"/> Bevel helical gear units |
| | | <input type="checkbox"/> Parallel shaft gear units |
| | | <input type="checkbox"/> Planetary gear units |
| | | <input type="checkbox"/> Other with IEC/servo adapter |
| <input type="checkbox"/> Reduced play _____ | | |
| <input type="checkbox"/> IP20 electronics | <input type="checkbox"/> IP55/IP66 electronics | <input type="checkbox"/> Motor-mounted |
| | | <input type="checkbox"/> Wand-mounted |
| | | <input type="checkbox"/> Cable length: _____ mm |
| <input type="checkbox"/> Ambient temperature of motor | <input type="checkbox"/> Ambient temperature of electronics | <input type="checkbox"/> Environment conditions (protection class, water, dirt, chemicals) |

6. Potential

Drive units per year: _____

NORD DRIVESYSTEMS Group

Headquarters and technology centre
in Bargteheide near Hamburg

Innovative drive solutions
for more than 100 branches of industry

Mechanical products
Parallel shaft, helical, bevel and worm gear units

Electrical products
IE2/IE3/IE4 motors

Electronic products
Cabinet and decentralised frequency inverters
and motor starters

7 production locations with cutting-edge technology
for all drive components

Subsidiaries and sales partners
in 98 countries on 5 continents
provide local stocks, assembly centres,
technical support and customer service.

More than 4,000 employees throughout the world
create customised solutions.

www.nord.com/locator

Headquarters:

Getriebebau NORD GmbH & Co. KG
Getriebebau-Nord-Str. 1, 22941 Bargteheide, Germany
T +49 4532 2890, F +49 4532 289 2253
info@nord.com

Member of the NORD DRIVESYSTEMS Group

