



LogiDrive[®]

Solution space for
post & parcel, airport and warehouse



NORD DRIVESYSTEMS Group

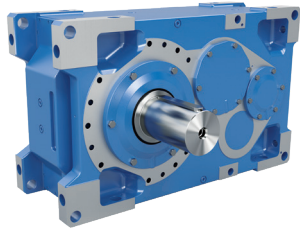

Industrial gear units

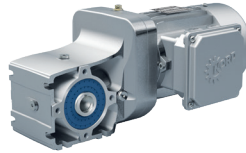

Geared motors

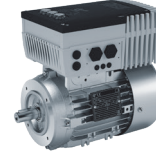

Frequency inverters and motor starters

- ▶ Headquarters and technology centre in Bargteheide near Hamburg
- ▶ Innovative drive solutions for more than 100 branches of industry
- ▶ 7 production locations with cutting edge technology produce gear units, motors and drive electronics for complete drive systems from a single source
- ▶ NORD has 48 subsidiaries in 36 countries and further sales partners in more than 50 countries. They provide local stocks, assembly centres, technical support and customer service
- ▶ More than 4,700 employees throughout the world create customised solutions



Headquarters in Bargteheide



Gear unit production



Inverter production



Motor production



Production and assembly



Motor mounting



LogiDrive[®] Drive Solutions



Airport



Post & Parcel

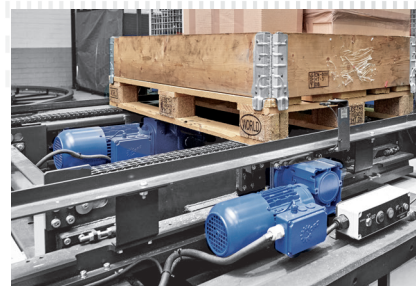

Warehouse

Our customers have very individual applications and requirements. We provide tried and tested safe solutions for many applications in the logistics industry.

Whether your focus is on efficiency, a small number of variants, software solutions or predictive maintenance – we have the right solution for you.

We call this our solution space. Tried and tested solutions for common applications with different objectives. Here you will find tried and tested solutions for the airport, post & parcel and warehouse sectors.

You have the possibility to directly apply this in your systems or to adjust your solution individually using our comprehensive modular system

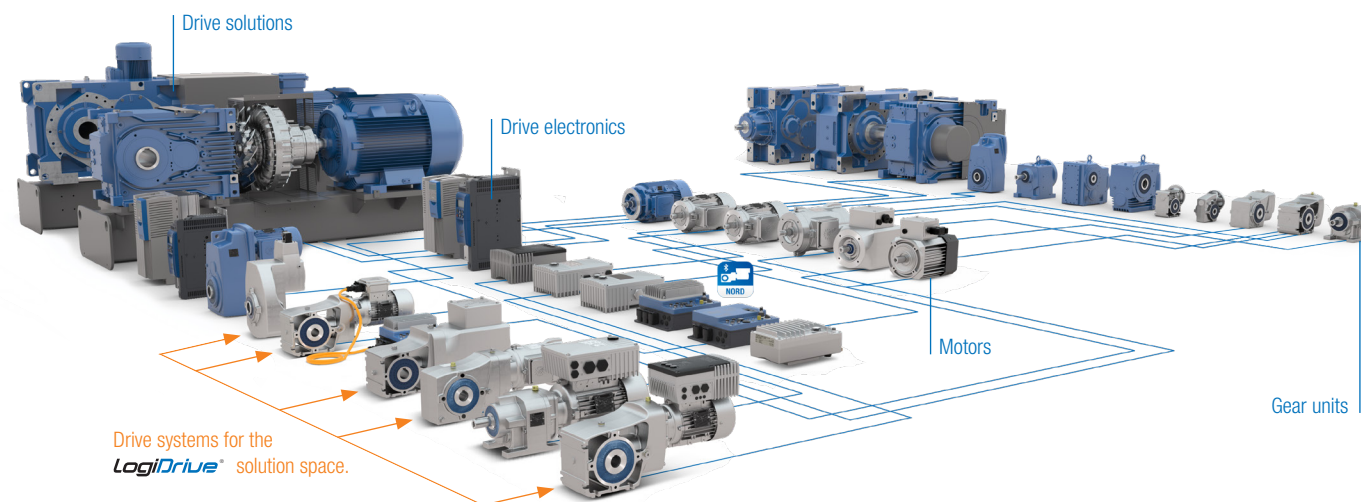

LogiDrive solution space

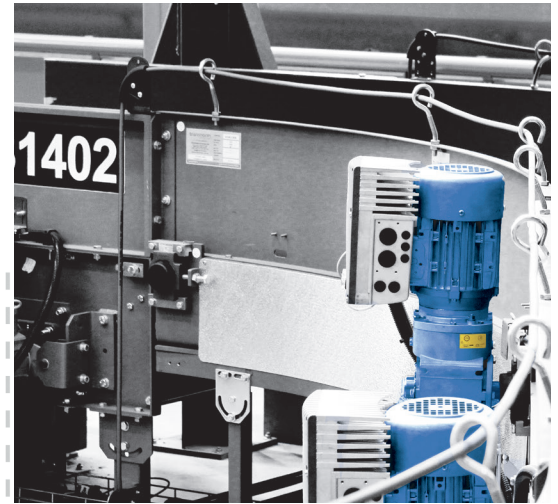

ADVANCED

- ▶ High efficiency (IE5+) with partial load ranges/speed due to PMSM technology
- ▶ Plug and Play
- ▶ High power density
 - ▶ BG 90 up to 3.7 kW
- ▶ High overload
- ▶ Compact design
- ▶ Global motor, global certifications
- ▶ High availability, e.g. version reduction/standardisation
- ▶ Simple installation, commissioning and service thanks to full pluggability
- ▶ Simple engineering
- ▶ Versatile
- ▶ Decentralised frequency inverter, motor- or wall-mounted
- ▶ NORDAC inverter
 - ▶ Ethernet interface can be enhanced via optional module
 - ▶ PROFI-safe possible
 - ▶ Large number I/O, can additionally expanded
 - ▶ Selectable motor parameters
 - ▶ Maintenance switch, key switch
 - ▶ PLC functionality for drive-related functions
- ▶ DuoDrive – Fewer wear-prone parts ensure the lowest possible downtimes and reduce maintenance costs
- ▶ The most efficient drive system on the market
- ▶ Universal mounting position (DuoDrive)
 - ▶ Version reduction
- ▶ Low noise level
- ▶ Integrated encoder in the motor
- ▶ High dynamics due to low inertia





LogiDrive[®] Solution space

POST & PARCEL AND AIRPORT

Baggage handling systems, parcel distribution systems, parcel sorting system

BASIC

- ▶ Reduced to the most essential
- ▶ Cost-optimised
- ▶ High overload
- ▶ Version reduction
- ▶ Flexible inverter configuration
- ▶ Optional Plug and Play
- ▶ Motor-mounted
- ▶ Flexible gear unit selection – modular
- ▶ ASM technology (IE3)
- ▶ Encoder optional
- ▶ Global motor, global certifications
- ▶ PLC functionality for drive-related functions

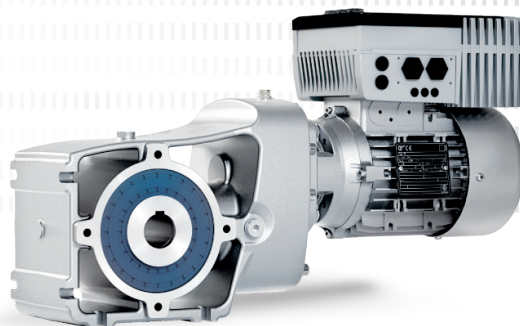
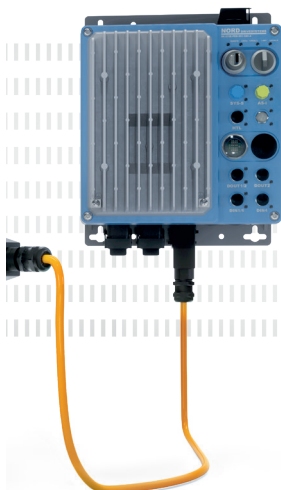

LogiDrive solution space

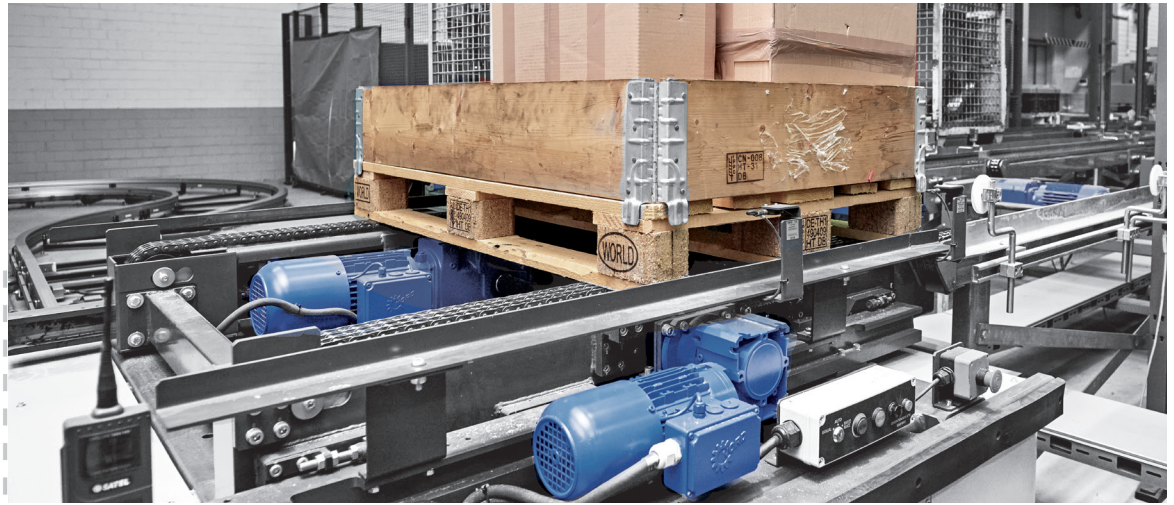

BASIC

- ▶ Plug and Play
- ▶ Tailored to specific applications
- ▶ Cost-optimised
- ▶ Standard variants
- ▶ Wide speed range
- ▶ Motor-mounted
- ▶ Simple installation, commissioning and service thanks to full pluggability
- ▶ Multi-dialect chip
- ▶ Firmware updates via industrial BUS possible
- ▶ ASM technology (IE3)
- ▶ Global motor, global certifications
- ▶ Flexible gear unit selection – modular
- ▶ Inverter-optimised motor winding, optimal for FI operation – 87 Hz
- ▶ PLC functionality for drive-related functions

ADVANCED

- ▶ High efficiency (IE5+) with partial load ranges/speed due to PMSM technology
- ▶ High-efficiency overall solution
- ▶ Plug and Play
- ▶ High power density
- ▶ Selectable motor parameters
- ▶ Wide speed range
- ▶ High overload
- ▶ Compact design
- ▶ Motor-mounted
- ▶ Global motor, global certifications
- ▶ Small size for a wide power range

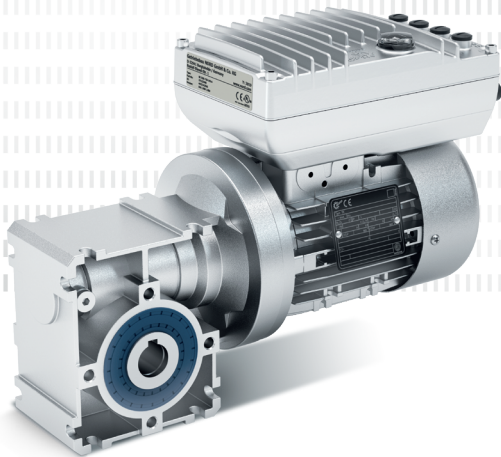

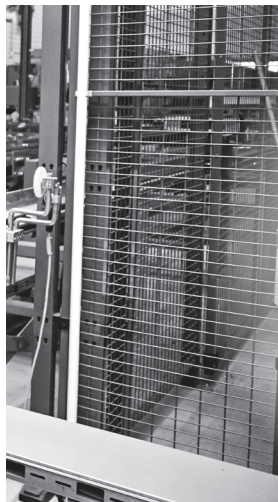

LogiDrive[®] Solution space

WAREHOUSE

Chain and roller conveyors, belt and pallet conveyor technology,
container conveyor technology, overhead conveyor

- ▶ High power density BG 90 up to 3.7 kW
- ▶ Multi-dialect chip
- ▶ Firmware updates via industrial BUS possible
- ▶ *FLEX*, for the time being for the higher power ranges (not covered by *ON*)
- ▶ PLC functionality for drive-related functions

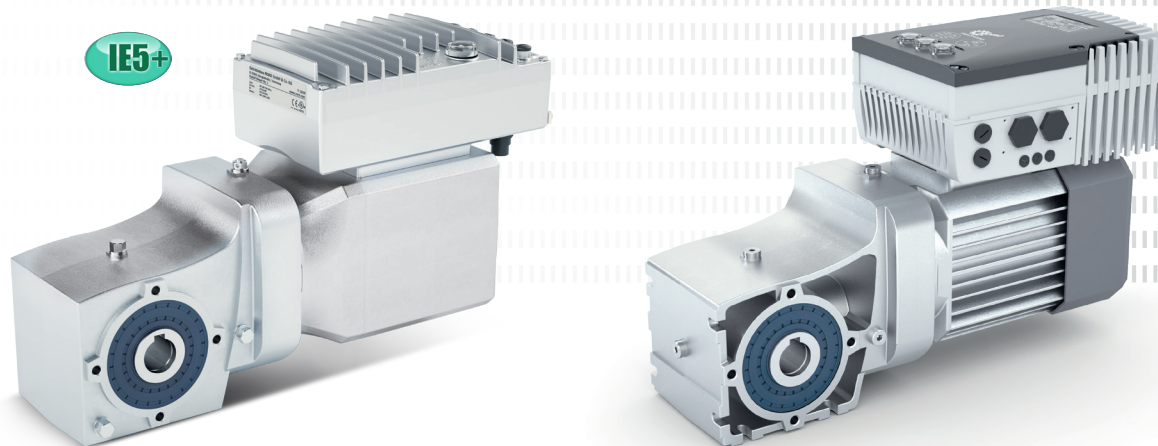



EN

Headquarters
Getriebebau NORD GmbH & Co. KG
Getriebebau-Nord-Str. 1
22941 Bargteheide, Deutschland
T: +49 45 32 / 289 0
F: +49 45 32 / 289 22 53
info@nord.com

Member of the NORD DRIVESYSTEMS Group

EN – S5210 Part no. 6093902 / 1222

