

Bucket elevators are designed for the vertical transport of large quantities of bulk materials. The containers are attached to an endless conveyor belt which continually runs around a drum at the bottom end of the elevator, where the containers are loaded. The loaded containers travel up and around the top drum, where they empty their load into the material discharge. After this, the containers travel down to the bottom end and the process continues.

Typical features of low capacity bucket elevators

UNICASE bevel gear units (Catalogue G1000)

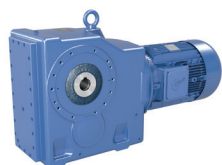

- ✓ Foot, flange or hollow shaft mounted
- ✓ Hollow or solid shaft
- ✓ Long life, low maintenance
- ✓ UNICASE housing

Sizes: 11
 Power: 0.12 – 200 kW
 Torque: 180 – 50,000 Nm
 Speed ratio: 8.04 – 13,432.68:1

UNICASE parallel shaft gear units (Catalogue G1000)



- ✓ Foot or flange-mounted
- ✓ Die-cast aluminium housing
- ✓ UNICASE housing
- ✓ Industry standard dimensions

Size: 15
 Power: 0.12 – 200 kW
 Torque: 110 – 100,000 Nm
 Ratio: 4.03:1 – 15,685.03:1

Gear unit options recommended by NORD DRIVESYSTEMS

Name	Meaning
A	Hollow shaft
AZ	Hollow shaft, B14 flange
AZD	Hollow shaft, B14 flange, with torque arm
AZK	Hollow shaft, B14 flange, with torque console
BH	Fastening element for hollow shaft with cover as a touch guard
G	Rubber buffer for torque arm (parallel shaft gear unit)
SH	Hollow shaft with shrink disc and cover as a touch guard

Motor options recommended by NORD DRIVESYSTEMS

RLS	Back stop
IP66	Protection against entry of water and dust
PTC/KTY/PT100	Temperature sensor
High-efficiency motors	
ATEX	Explosion protected motors for explosion hazard areas

NORD drive solutions are used worldwide in industries that rely on bucket elevators.

- ▶ Food industry
- ▶ Mining industry
- ▶ Cement and mineral industry
- ▶ Fertilizer industry
- ▶ Chemical industry

Complete drive solutions from a single source

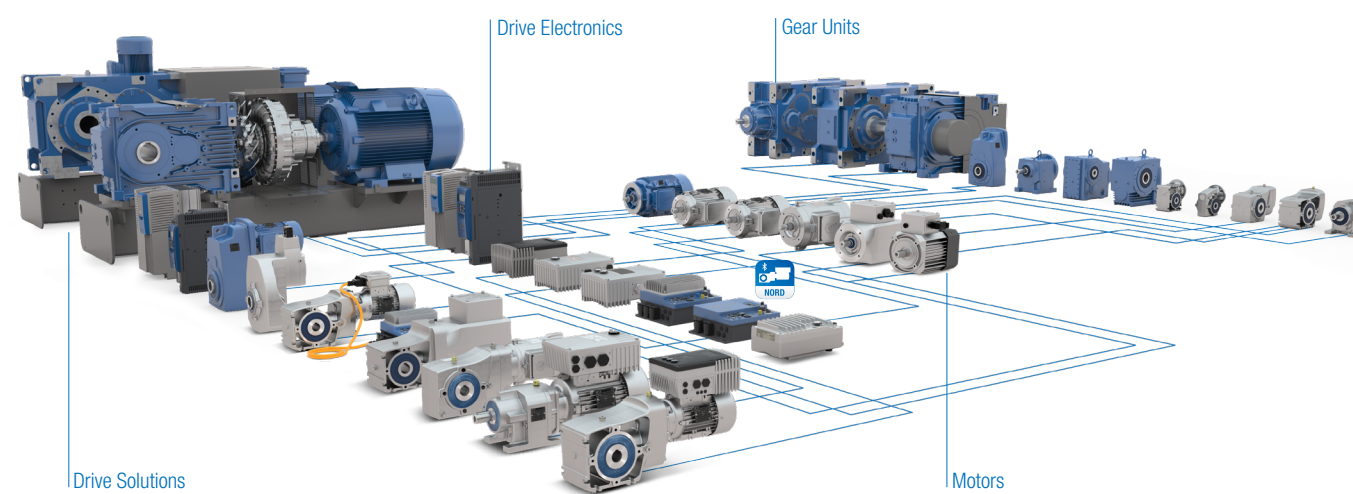

NORD DRIVESYSTEMS Group

- ▶ Family business from Bargteheide near Hamburg with more than 4,100 employees
- ▶ Drive solutions for more than 100 branches of industry
- ▶ 7 production locations worldwide
- ▶ Present in 98 countries on 5 continents
- ▶ More information: www.nord.com

Headquarters:
 Getriebebau NORD GmbH & Co. KG
 Getriebebau-Nord-Str. 1
 22941 Bargteheide, Germany
 T: +49 45 32 / 289 0
 F: +49 45 32 / 289 22 53
info@nord.com

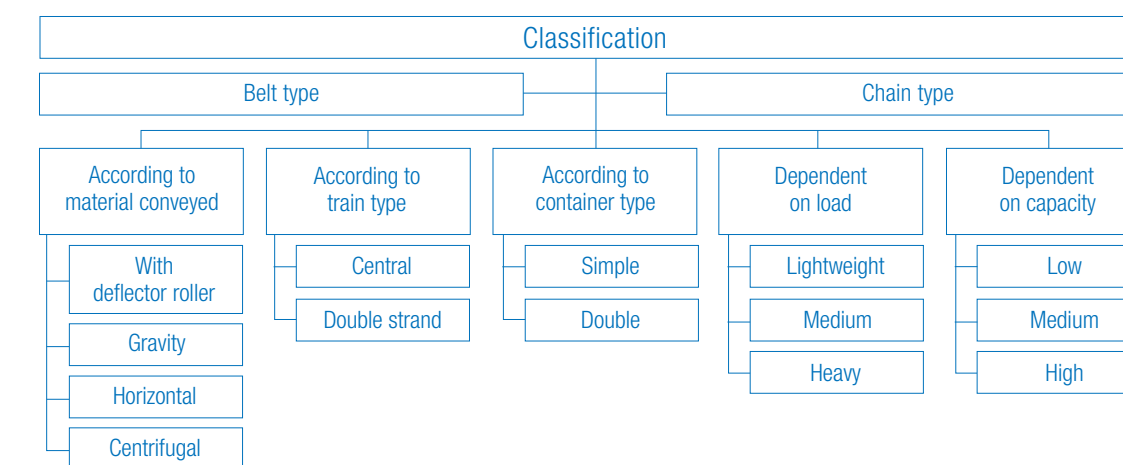

Versions

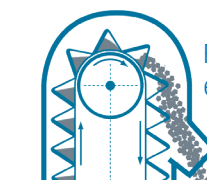

Full bucket elevator

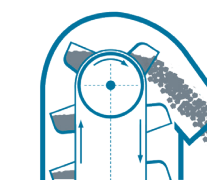

Centrifugal bucket elevator

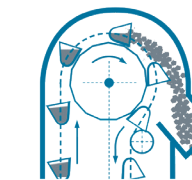

Bucket elevator with deflector roller

- ▶ Low speed
- ▶ Closely spaced containers
- ▶ Direct filling of material into the containers via conveyor ramp
- ▶ Tipping of material from the inverted containers into the discharge shaft

- ▶ High speed
- ▶ Material shovelled out at the bottom of the system
- ▶ Discharge by centrifugal force
- ▶ For fine grain size

- ▶ Low speed
- ▶ For light material which tends to stick in the containers
- ▶ The load is picked up at the bottom as for centrifugal bucket elevators
- ▶ Discharge by inverting the buckets at low speed

Drive solutions for bucket elevator applications

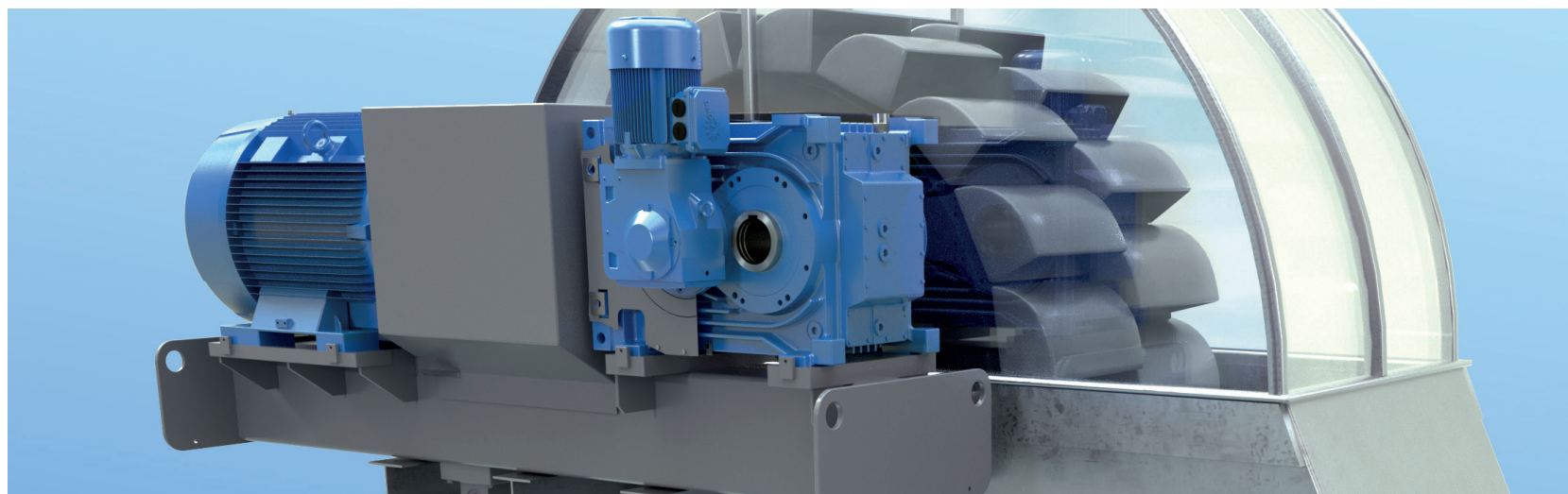

NORD explosion protected drive solutions

Drive systems for explosion hazardous areas Zones 1, 2, 21 or 22

NORD DRIVESYSTEMS supplies customised explosion protected motors and geared motors. Systems based on top quality components are designed according to application in compliance with specific customer requests.

- ▶ Versions and equipment according to individual requirements

Dust explosion protected motors

- ▶ According to Category 2D or 3D
- ▶ For Zone 21 or 22
- ▶ According to EN 60079-31
- ▶ Ignition protection Ex t (Protection by housing)

- ▶ Configuration processes validated according to ISO 9001
- ▶ Safe, SAP-supported modular system

Dust explosion protected gear units

- ▶ According to Category 2D or 3D
- ▶ For Zone 21 or 22
- ▶ According to EN 13463
- ▶ Ignition protection c (Design protected)

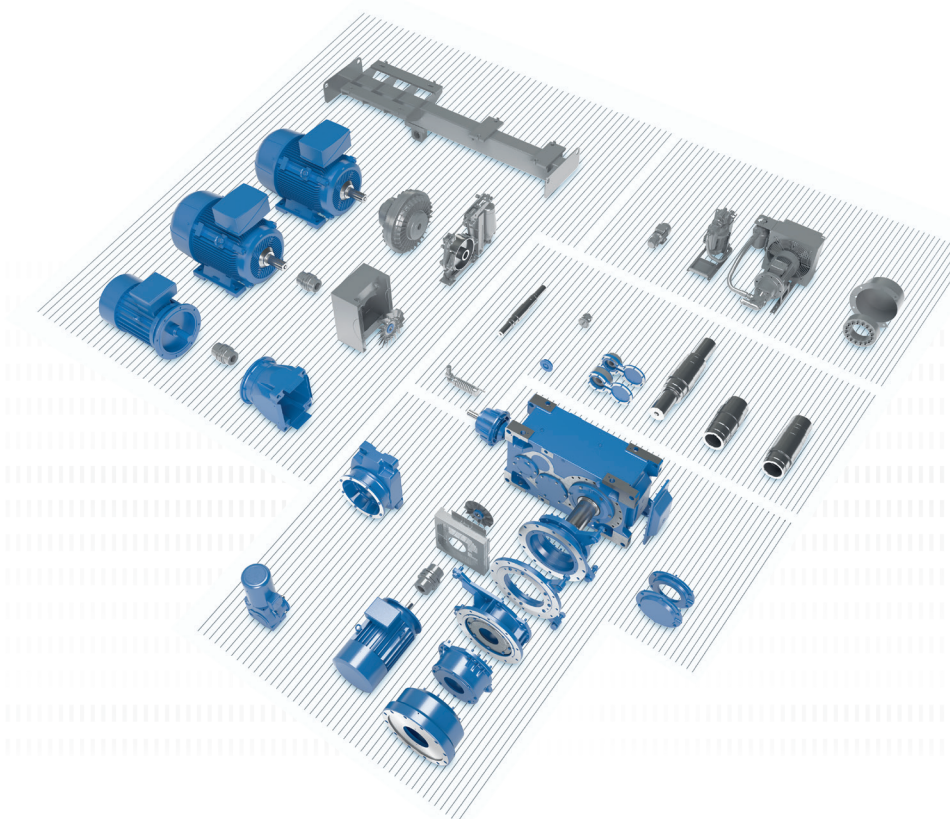

Drive solutions for high capacity bucket elevators

MAXXDRIVE® industrial gear units (Catalogue G1050)

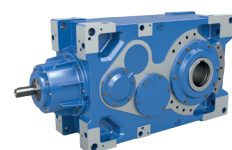

- ✓ Universal gear units
- ✓ Helical gear units 2- and 3-stage
- ✓ Helical bevel gear units 3- and 4-stage
- ✓ Multiple mounting and cooling options
- ✓ Modified bearing options for high radial and axial load capacity
- ✓ Compact design
- ✓ All installation positions

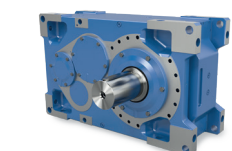

Sizes: 11
Power: 1.5 – 4,000 kW
Torque: 15,000 – 282,000 Nm
Speed ratio: 5.54 – 30,000:1

MAXXDRIVE® XT industrial gear units (Catalogue G1050)



- ✓ Optimised housing and surface design for maximum power at high temperatures
- ✓ No separating joints in the housing, therefore no sealing-surfaces subject to torque
- ✓ All bearings and sealing-surfaces are machined in a single process (quieter running and longer service life)
- ✓ High-precision axis alignment for quiet running
- ✓ Long life, low maintenance
- ✓ Angled gear units

Size: 7
Power: 50 – 1,500 kW
Torque: 15,000 – 75,000 Nm
Ratio: 6,14 – 22,91:1

- ▶ MAXXDRIVE® industrial gear units (hollow or solid shaft)
- ▶ Foot mounted motor (IEC B3)
- ▶ Hydraulic coupling
- ▶ Back stop
- ▶ Brake
- ▶ All components are mounted on a motor rocker or frame
- ▶ High efficiency IE3 motor
- ▶ ATEX motors for conveyor belts in explosion hazard areas

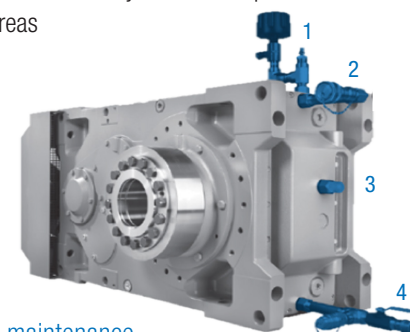

The NORD maintenance package is a combination of protective measures which ensures that your investment will continue to function for a long time to come.

- 1 Drying agent filter
- 2 Quick fit filter trolley connection
- 3 Oil inspection glass
- 4 Quick fit filter trolley connection and oil drain cock

Frequency inverter controlled bucket elevators

Advantages

- ▶ Easy commissioning
- ▶ Variable speed
- ▶ Adjustable torque ramp
- ▶ Safety functions
- ▶ High efficiency
- ▶ Load-dependent speed control reduces wear
- ▶ Parameterisation according to process requirements

NORDAC FLEX SK 200E frequency inverter (Catalogue E3000)

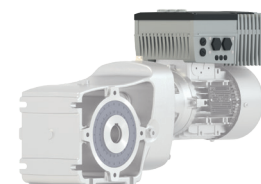

- ✓ Energy-saving function
- ✓ Integrated POSICON positioning control
- ✓ Integrated PLC

Voltage: 1~ 110 – 120 V, 1~ 200 – 240 V
3~ 200 – 240 V, 3~ 380 – 500 V
Power: 0.25 – 22 kW

NORDAC PRO SK 500E frequency inverter (Catalogue E3000)



- ✓ Stand-alone operation
- ✓ 4 parameter sets
- ✓ Sensorless current vector control (ISD control)
- ✓ Integrated PLC

Voltage: 1~ 110 – 120 V, 1~ 200 – 240 V
3~ 200 – 240 V, 3~ 380 – 480 V
Power: 0.25 – 160 kW

Recommended options for high capacity bucket elevators

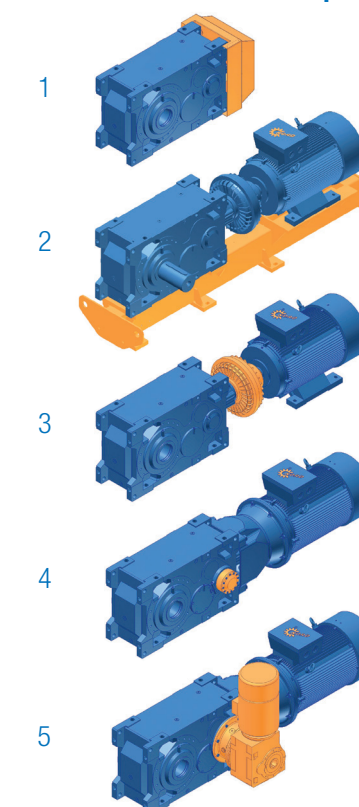

MAXXDRIVE® industrial gear units are based on the modular system from NORD DRIVESYSTEMS and provide many individual options such as:

1 Axial fans

The high performance axial fan is mounted directly on the drive shaft and provides a high cooling power and a thermal reserve.

2 Base frame/motor rocker

All mechanical and electrical components are mounted on a motor rocker or a motor frame, which simplifies the installation of the drive train.

3 Fluid coupling

The fluid coupling enables the conveyor belt to start gently and therefore prevents excessive tensile forces on the belt and high torques in the gear unit. In addition, it reduces the starting current.

4 Back stop

The back stop prevents run-back with inclined conveyor belts. All back stops are externally mounted and can be replaced without having to dismantle the gear unit. The back stops are also lubricated with the gear oil.

5 Auxiliary drive unit

Auxiliary Drive incl. overrunning clutch when it becomes necessary to operate the system at slow speed or "inch" the main reducer.

6 Taconite seal

The Taconite seal prevents damage to the shaft sealing rings in abrasive or dusty environments. It consists of a labyrinth seal which can be re-lubricated to keep abrasive dust away from the seal.